

## METRO 40 TRACK LIGHTS



LED WATTS	CODE	SYSTEM WATTS	POWER FACTOR	FINISH	COLOUR	LUMENS	EFFICACY
13W	BL-CS-7000-WW	15W	≥0.90	White	Warm White 3000K	1000lm	66lm/W
	Natural White 4000K				1100lm	73lm/W	
	BL-CS-7001-WW			Black	Warm White 3000K	1000lm	66lm/W
	BL-CS-7001-NW				Natural White 4000K	1100lm	73lm/W
25W	BL-CS-7002-WW	28W	≥0.95	White	Warm White 3000K	1900lm	67lm/W
	BL-CS-7002-NW				Natural White 4000K	2000lm	71lm/W
	BL-CS-7003-WW			Black	Warm White 3000K	1900lm	67lm/W
	BL-CS-7003-NW				Natural White 4000K	2000lm	71lm/W

IES FILES AVAILABLE

VOLTS	220–240V AC 50/60Hz input	CRI	90	DIMENSIONS	Base W54 × L148 × H37mm Light Ø72 × L137mm
OPERATING TEMP.	-20°C ~ +40°C	BEAM ANGLE	40° <i>18° and 25° reflector accessories available</i>	ADJUSTMENT	90° tilt 359° rotation
		SOURCE LIFE	50,000 hours	HOUSING	Die-cast aluminium
		LED BRAND	Citizen	BAFFLE	Black <i>White available upon request</i>
		WARRANTY	5 years	WEIGHT	0.95kg
		COMPLIANCE		INGRESS PROTECTION	Indoor use only
				CONNECTION METHOD	3-phase track connector
				CONTROL	Non-dimmable <i>DALI options available</i>

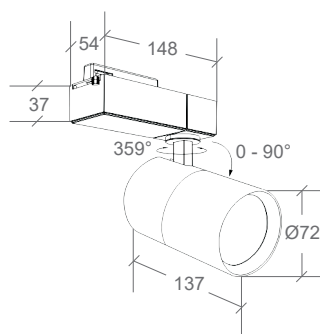

### REFLECTORS

ACCESSORY	CODE
18° BEAM	BL-CS-70018
25° BEAM	BL-CS-70025

IES FILES AVAILABLE