

LIGHTING 6-CIRCUIT TRACK SYSTEM

Installation Guide

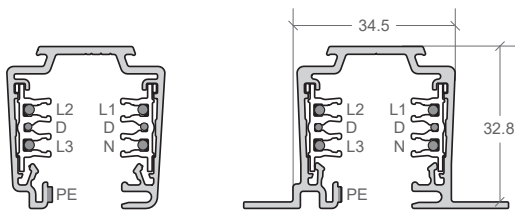

250V AC · 16A · 50/60Hz · Class I · IP20
Compatible with 1-10V, DALI



SURFACE MOUNTED

RECESSED

| | | | |
|--|---|--|---|
| | <p>BL-CS-TC34W Surface Mounted White Track BL-CS-TC34B Surface Mounted Black Track BL-CS-TC34FW Recessed White Track BL-CS-TC34FB Recessed Black Track</p> | | <p>BL-CS-CCU3AW White Connection Unit A BL-CS-CCU3BW White Connection Unit B BL-CS-CCU3AB Black Connection Unit A BL-CS-CCU3BB Black Connection Unit B</p> |
| | <p>BL-CS-CJU3 Joint Connector Black or white cover</p> | | <p>BL-CS-CMCU3W White Middle Connector BL-CS-CMCU3B Black Middle Connector</p> |
| | <p>BL-CS-CLC3W 90° White Corner Connector BL-CS-CLC3B 90° Black Corner Connector</p> | | <p>BL-CS-A100W White Pendant Adaptor BL-CS-A100B Black Pendant Adaptor</p> |
| | <p>BL-CS-CXA3W White X-Angle Connector BL-CS-CXA3B Black X-Angle Connector</p> | | <p>BL-CS-CTA3AW White T-Angle Connector A BL-CS-CTA3BW White T-Angle Connector B BL-CS-CTA3CW White T-Angle Connector C BL-CS-CTA3DW White T-Angle Connector D BL-CS-CTA3AB Black T-Angle Connector A BL-CS-CTA3BB Black T-Angle Connector B BL-CS-CTA3CB Black T-Angle Connector C BL-CS-CTA3DB Black T-Angle Connector D</p> |
| | <p>BL-CS-CEC3W White End Cap BL-CS-CEC3B Black End Cap</p> | | |
| | <p>BL-CS-CS3W White Blank Cover BL-CS-CS3B Black Blank Cover</p> | | <p>BL-CS-CCP3W White Recessed Cover Plate BL-CS-CCP3B Black Recessed Cover Plate</p> |

NOTE:









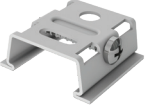

Only components belonging to this track system should be used, and the components must be installed according to these installation instructions.

Bright Light is not responsible for the safety and function of this system if components not belonging to this system are used, or if the installation instructions are not followed.

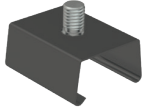
It is the user's responsibility to ensure the electrical, mechanical, and thermal compatibility between the system and the fixtures attached to it.

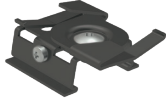
The user must test all connections and electrical lines before attaching luminaires or other features to the system.

MOUNTING ACCESSORIES

| | |
|--|---|
|  <p>BL-CS-CB3W White Ceiling Bracket BL-CS-CB3B Black Ceiling Bracket</p> |  <p>BL-CS-WBW White Wall Bracket BL-CS-WBB Black Wall Bracket</p> |
|  <p>BL-CS-WS40H Adjustable Suspension Kit With Hook (4m) Silver BL-CS-WS40HB Adjustable Suspension Kit With Hook (4m) Black</p> |  <p>BL-CS-WS40 Silver Wire Suspension BL-CS-WS40B Black Wire Suspension</p> |
|  <p>BL-CS-PBW White Pendant Bracket BL-CS-PBB Black Pendant Bracket</p> |  <p>BL-CS-QCBW White Quick Ceiling Bracket BL-CS-QCBB Black Quick Ceiling Bracket</p> |
|  <p>BL-CS-PCW White Pendant Coupler BL-CS-PCB Black Pendant Coupler</p> |  <p>BL-CS-CB3WT White T-Bar Ceiling Bracket BL-CS-CB3BT Black T-Bar Ceiling Bracket</p> |
|  <p>BL-CS-GT-6 Silver Threaded Rod BL-CS-SS-6W White Sleeve for Threaded Rod</p> | |
|  <p>BL-CS-CBCW White Ceiling Bracket with Cup BL-CS-CBCB Black Ceiling Bracket with Cup</p> | |
|  <p>BL-CS-PBAW White Adjustable Pendant Bracket BL-CS-PBAB Black Adjustable Pendant Bracket</p> | |

CONNECTION UNIT

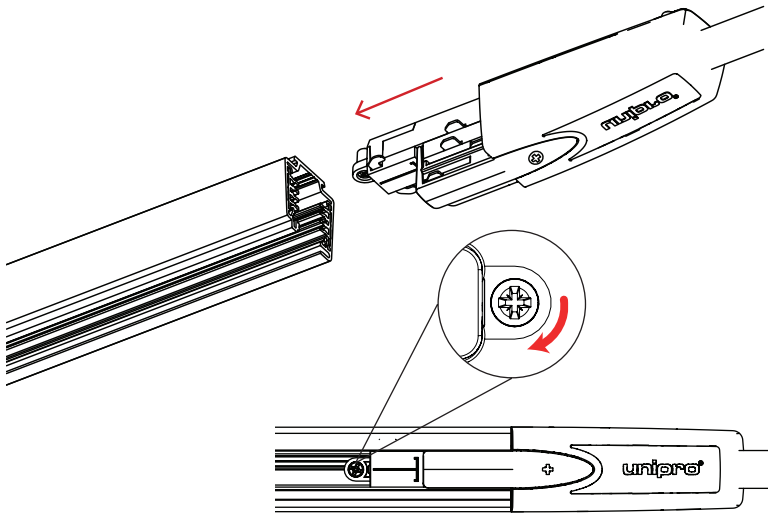

CONNECTION UNIT A

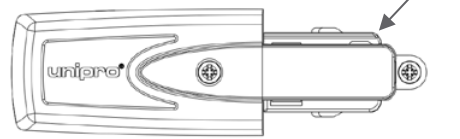

WHITE BL-CS-CCU3AW
BLACK BL-CS-CCU3AB

CONNECTION UNIT B

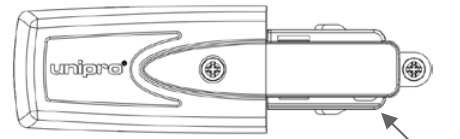

WHITE BL-CS-CCU3BW
BLACK BL-CS-CCU3BB

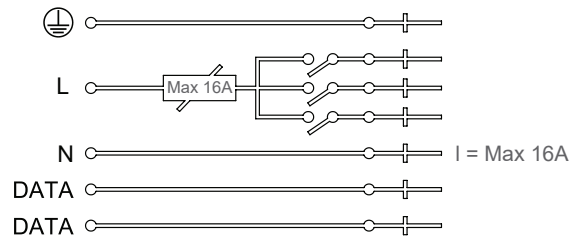
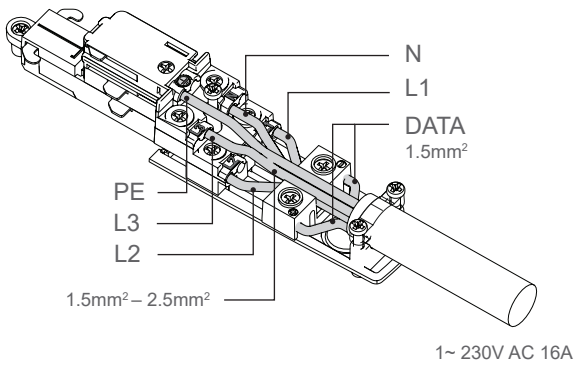

JOINT CONNECTOR BL-CS-CJU3

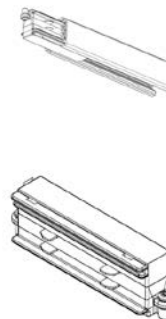
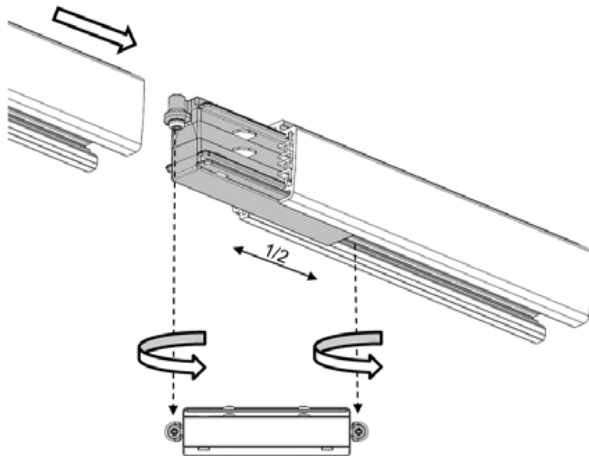

WHITE

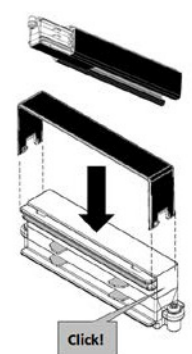

BLACK

MIDDLE CONNECTOR

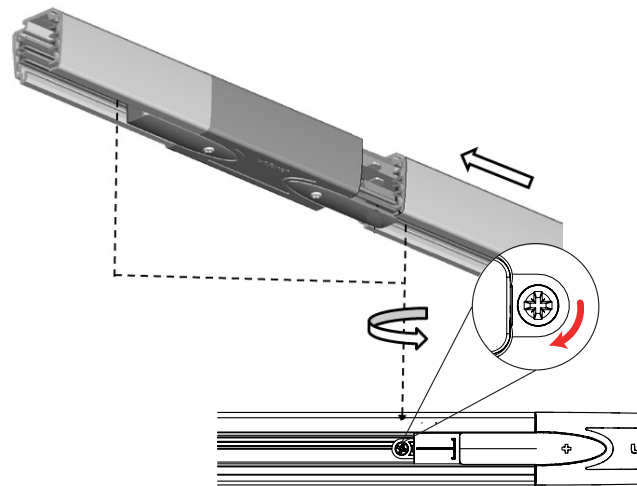

WHITE BL-CS-CMCU3W
BLACK BL-CS-CMCU3B

90° CORNER CONNECTOR

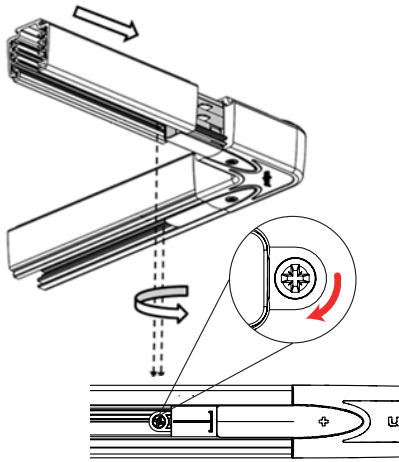

TO CHANGE POLARITY:

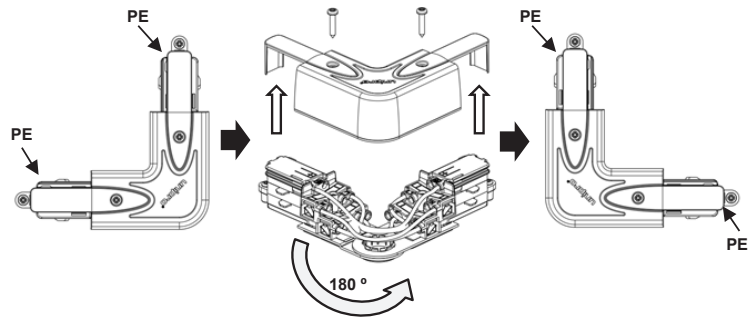

T-ANGLE CONNECTOR BLACK OR WHITE

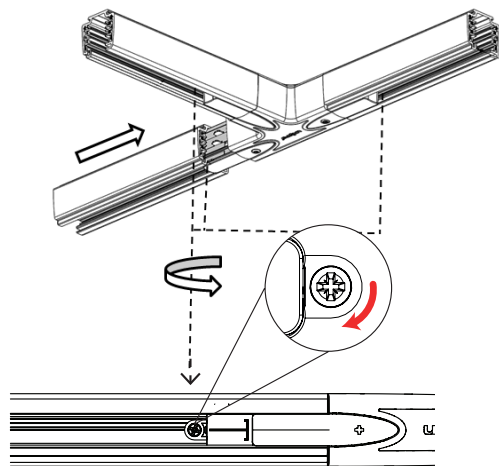

CONNECTION UNIT A

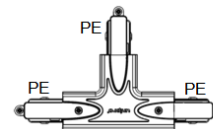

WHITE BL-CS-CTA3AW
BLACK BL-CS-CTA3AB

CONNECTION UNIT B

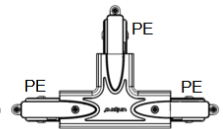

WHITE BL-CS-CTA3BW
BLACK BL-CS-CTA3BB

CONNECTION UNIT C

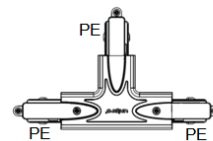

WHITE BL-CS-CTA3CW
BLACK BL-CS-CTA3CB

CONNECTION UNIT D

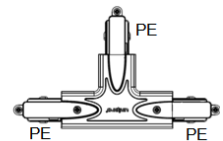

WHITE BL-CS-CTA3DW
BLACK BL-CS-CTA3DB

X-ANGLE CONNECTOR

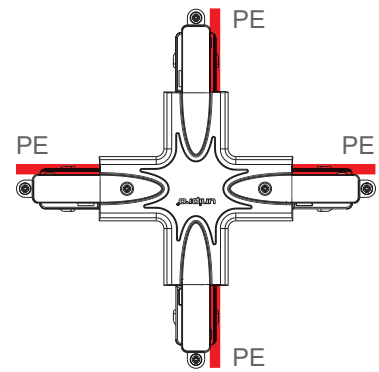
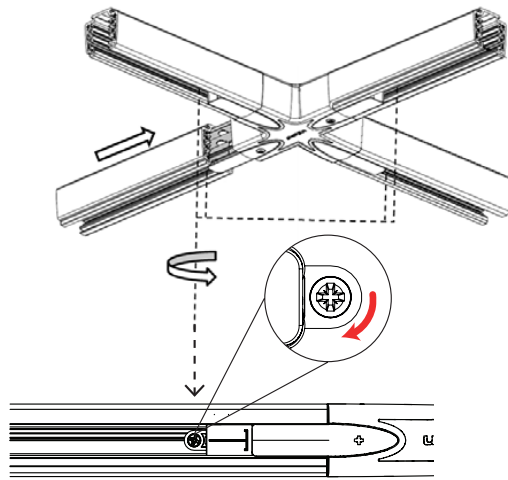

WHITE BL-CS-CXA3W
BLACK BL-CS-CXA3B

END CAP

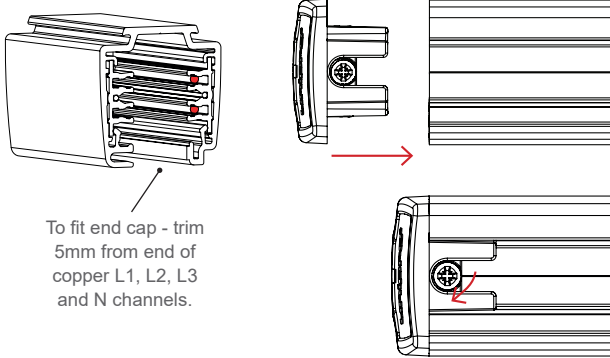

To fit end cap - trim
5mm from end of
copper L1, L2, L3
and N channels.

WHITE BL-CS-CEC3W
BLACK BL-CS-CEC3B

BLANK COVER

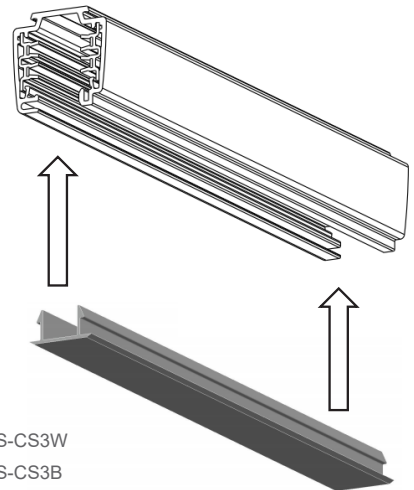

WHITE BL-CS-CS3W
BLACK BL-CS-CS3B

RECESSED TRACK COVER PLATE

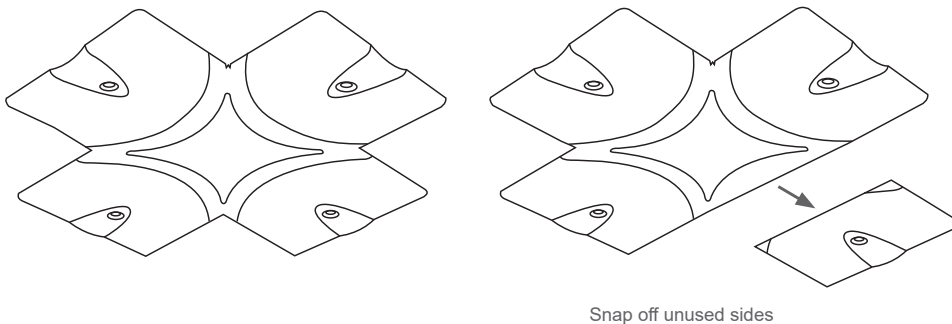

Snap off unused sides

WHITE BL-CS-CCP3W
BLACK BL-CS-CCP3B

Can be used with:

- Connection Units
- Middle Connectors
- 90° Corner Connectors
- T-Angle Connectors
- X-Angle Connectors

SURFACE & RECESSED MOUNTED INSTALLATION

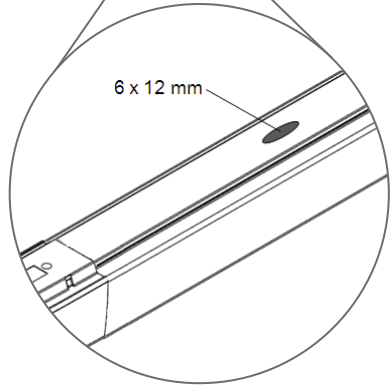
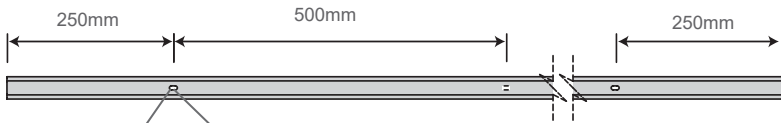

Screw mounting track

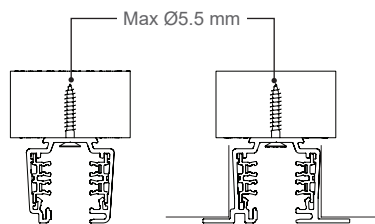

CEILING BRACKET

Max F: 200N (20kg)
Min. 2.5 Nm

Ceiling bracket

| | |
|-------|------------|
| WHITE | BL-CS-CB3W |
| BLACK | BL-CS-CB3B |

6-Circuit Track - Surface Mount

- WHITE BL-CS-TC34W
- BLACK BL-CS-TC34B

6-Circuit Track - Recessed Mount

- WHITE BL-CS-TC34FW
- BLACK BL-CS-TC34FB

T-BAR MOUNTED INSTALLATION

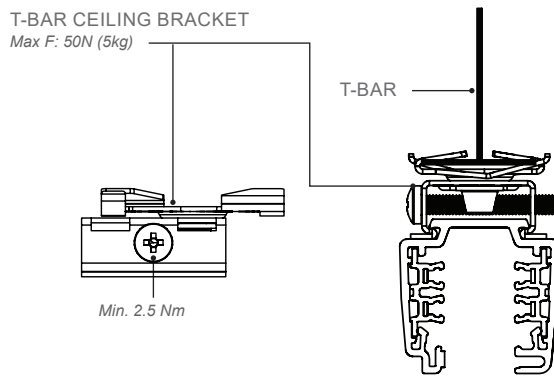

T-Bar Ceiling bracket

- WHITE BL-CS-CB3WT
- BLACK BL-CS-CB3BT

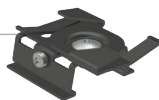

PHYSICAL LOADING

For all mounting types (surface, recessed and suspended) physical loading should be spread out across length as per diagrams below.

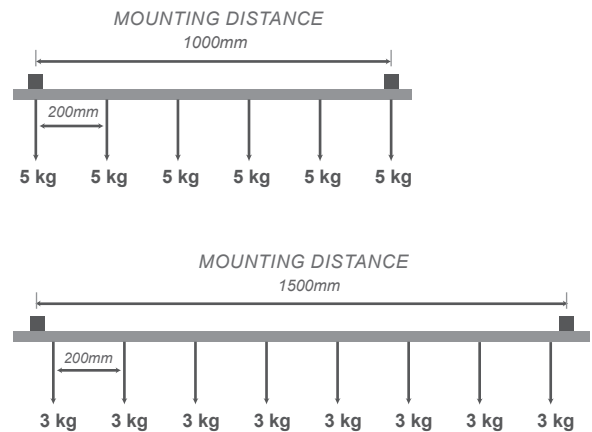

HOOK SUSPENSION INSTALLATION



Hook Suspension Kit
 SILVER BL-CS-WS40H
 BLACK BL-CS-WS40HB
 Max F: 100N (10kg)

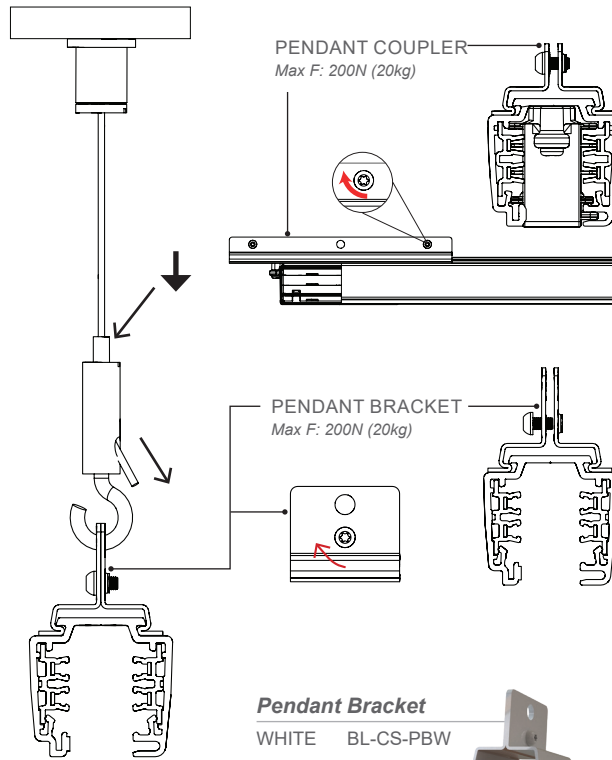

Pendant Bracket
 WHITE BL-CS-PBW
 BLACK BL-CS-PBB



Pendant Coupler
 WHITE BL-CS-PCW
 BLACK BL-CS-PCB
 For use over track joins



Options for Hook Suspension Mounting

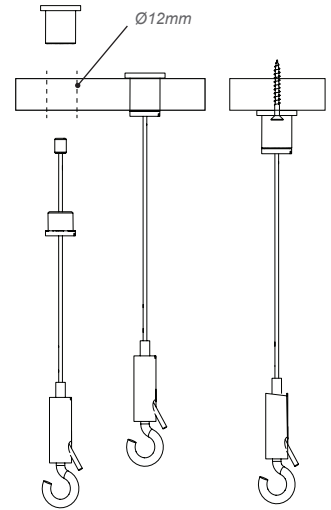

WIRE SUSPENSION INSTALLATION



Wire suspension
 SILVER BL-CS-WS40
 BLACK BL-CS-WS40B
 Max F: 150N (15kg)

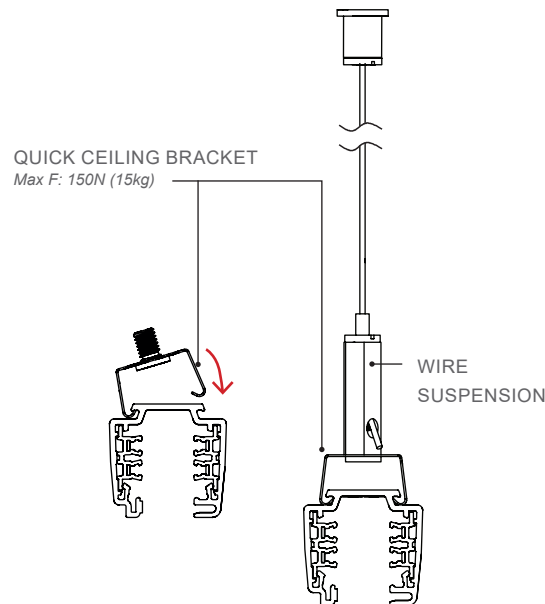

Quick Ceiling Bracket
 WHITE BL-CS-QCBW
 BLACK BL-CS-QCBB

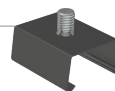

Options for Wire Suspension Mounting

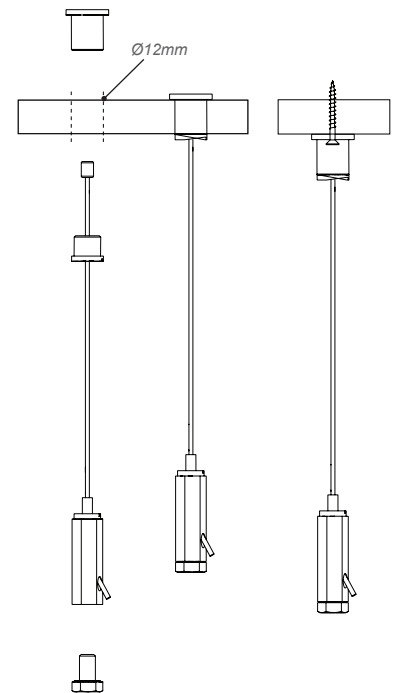

THREADED ROD SUSPENSION INSTALLATION

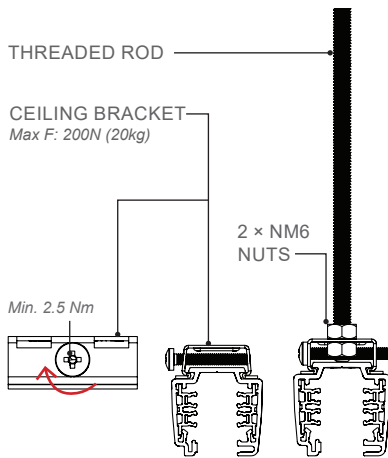

Threaded Rod

BL-CS-GT-6



Ceiling Bracket

WHITE BL-CS-CB3W
BLACK BL-CS-CB3B

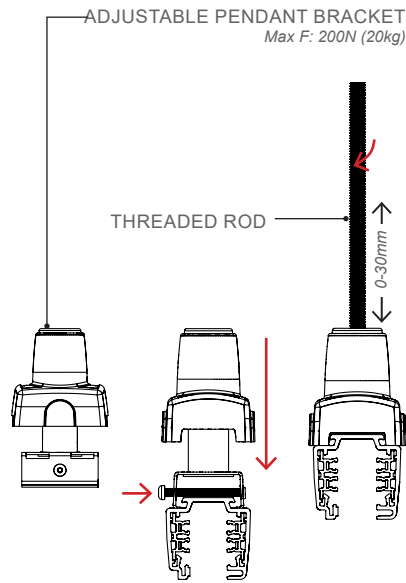
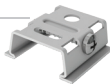

Adjustable Pendant Bracket

WHITE BL-CS-PBAW
BLACK BL-CS-PBAB

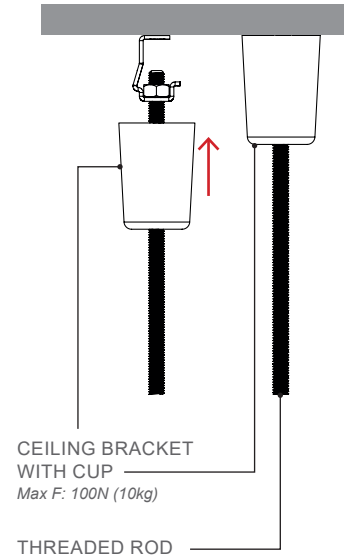

Ceiling Bracket with cup

WHITE BL-CS-CBCW
BLACK BL-CS-CBCB

