

CUSTOM BUILD HIGHLINE 05 - JOINING A SQUARE OR RECTANGLE WITH 90° JOINERS



TOP JOINER



JOINER PLATE

JOINING HIGHLINE 05 LUMINAIRES SHOULD ONLY BE DONE WHERE LUMINAIRES ARE CUSTOM BUILT & INCLUDE JOINERS.

ACCESSING JOINERS MAY EXPOSE LUMINAIRE POWER SUPPLY. ALWAYS ENSURE FITTING IS ALWAYS UNPOWERED WHEN JOINING IS UNDERTAKEN.

NOTE: Diffuser may need to be removed to access side joiner plates and tighten sockets.

NOTE: Diffuser may need to be removed to access side joiner plates and tighten sockets.

1. **If suspending**, you will need to slide suspension wires into profile top channels **prior** to joining (as top joiners will block the entry).
2. Loosen sockets in all joiners to ensure they sit flush and can be inserted in the profile.
3. Lay out the four pieces in the designed shape (ensure surface is smooth and won't scratch lengths - ie carpet). *If plug connectors are supplied this will govern the layout of pieces.*
4. Select two opposite pieces and insert the joiners into both ends of these pieces:
 - Insert top joiners into top channels (shared with suspension) half way.
 - Insert joiner plates half way into profile sides (diffuser section). *These plates are very important as they take most of the profile weight, they also function to block potential light bleed.*
5. Leave the other two sides free from all joiners as this allows for the joiner pieces to be aligned and slid inwards to connect with the non-joiner lengths. Shown in diagram on right.
6. Connect one side of rectangle at a time and tighten all joiners (this will involve lifting or flipping the whole shape over to access sockets on both top and plate joiners). Ensure close join with no gaps between profiles. *It may be beneficial for one person to hold the profile lengths close together, while another person tightens the sockets.*
7. If plug connectors are supplied, make electrical connections.
8. Repeat step 6-7 for opposite side.
9. **If suspending**, refit diffusers and see **A. SUSPENSION WIRE INSTALLATION**
10. **If surface mounting**, leave diffuser out and see **B. SURFACE MOUNTED INSTALLATION**

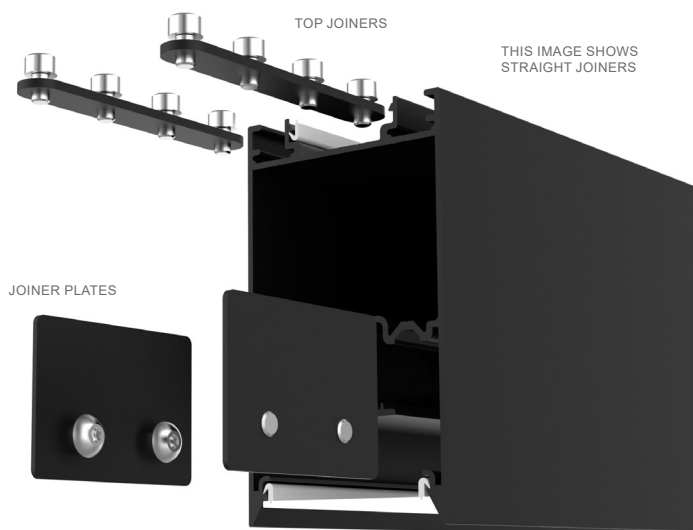
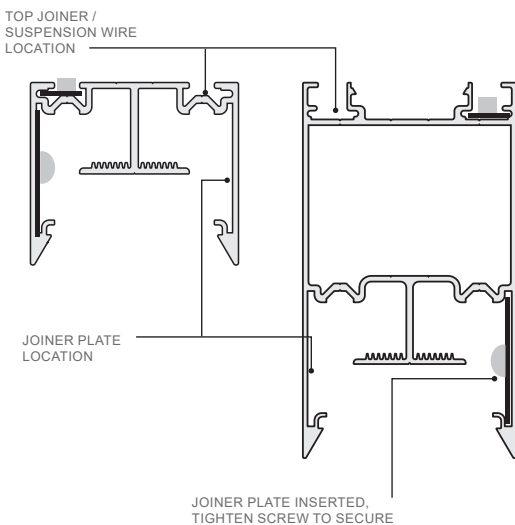
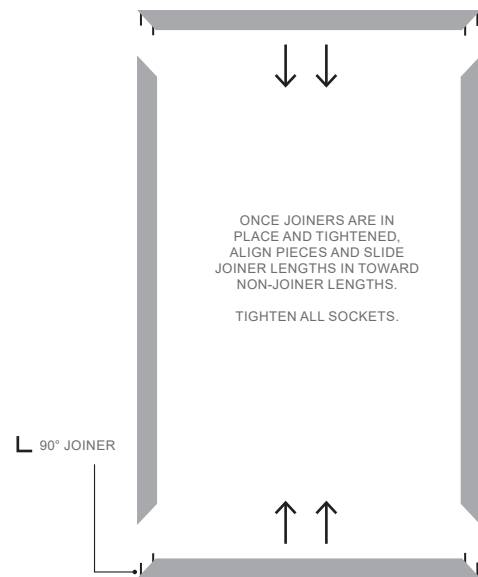

CUSTOM BUILD HIGHLINE 05 - JOINING A SQUARE OR RECTANGLE WITH 90° JOINERS

A. SUSPENSION WIRE INSTALLATION INSTALLATION INTO WOOD

1. If suspending into pitched ceiling go to **D: PITCHED CEILING SUSPENSION**
2. Slide suspension wires to desired location along luminaire (maximum distance of 3 metres between wires).
3. Unscrew upper cable gripper from barrel base and screw mount barrel base to support.
4. Thread suspension cable through upper cable gripper, barrel base and out cable hole, then rescrew upper cable gripper.
5. **To adjust suspension length:** While the luminaire weight is supported, suspensions can be shortened by pulling the cable through either of the cable grippers. To lengthen, press cable gripper buttons inwards to release the wire.
6. Suspension wires can be cut down to length once installed.
7. Go to **C: ELECTRICAL CONNECTION**

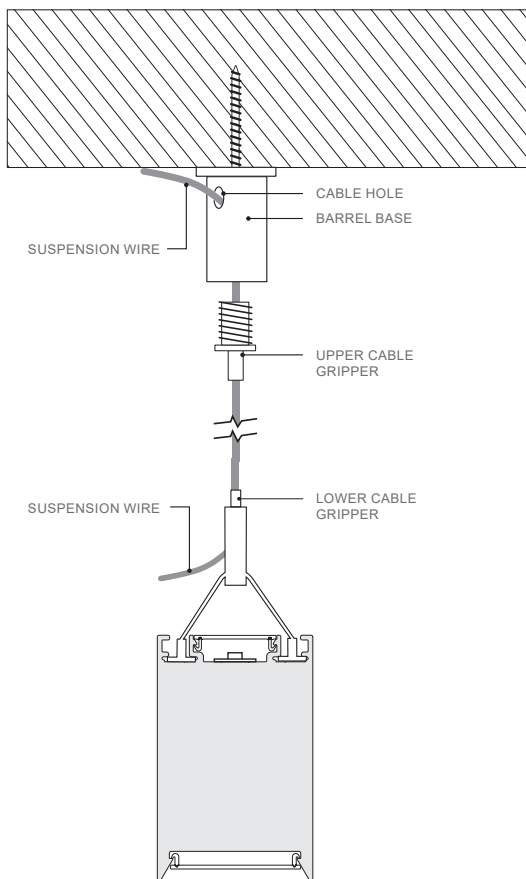

B. SURFACE MOUNTED INSTALLATION (DOWN LIGHT ONLY) INSTALLATION INTO WOOD

1. Drill cable entry hole in ceiling for LED power feed.
2. Remove diffuser, by peeling out from one end.
3. Pre-drill countersink channels for screws. For the 78mm and 100mm models, screws will need to go through two screw channel sections of the profile before they reach surface.
4. Screw mount profile through countersink channels. Screws are recommended **within 100mm from each end** and even spacing in the middle (maximum distance of 1 metre between screws).
5. Slot one end of diffuser into the end cap, then move along the luminaire length clicking diffuser into place. When 100mm from edge, bend diffuser up to slot into second end cap.
6. Go to **C: ELECTRICAL CONNECTION**

HIGHLINE 05 50MM

CONNECT TO MAINS POWER

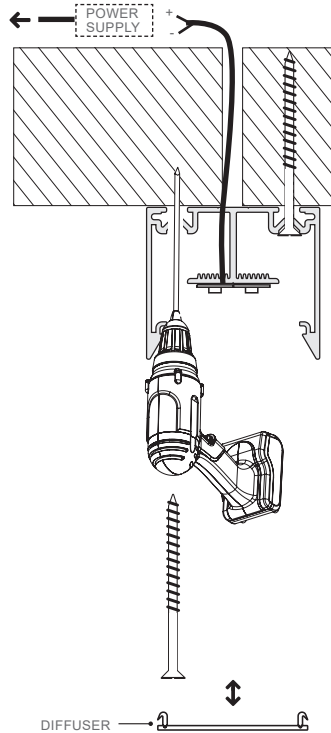

HIGHLINE 05 78MM / 100MM

CONNECT TO MAINS POWER

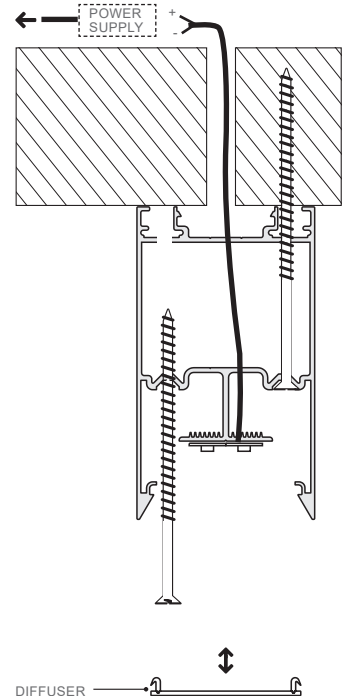

Surface not as level as you thought?

If, after installation, you notice the ceiling/surface is slightly uneven or has gaps, a quick fix is to add a touch of silicone.

Put a line of masking tape along the top luminaire edge and another along the ceiling edge, leaving the 1-2mm uneven gap exposed. Run a small line of white silicone (to match ceiling) along this exposed gap strip, smooth out with a wet finger/soft instrument. While the silicone is still wet, peel off both lines of masking tape simultaneously to leave a clean finish.

C. ELECTRICAL CONNECTION

1. Drill cable entry hole in ceiling for power feed cable (if using cable base - **E: CEILING ROSE/CABLE BASE INSTALLATION**).
2. **For all custom-builds** the external power supply will need to be mounted in the ceiling. Connect mains power to the power supply/driver primary input (to be done by registered electrician in compliance with local standards) and then connect the power supply secondary to the luminaire.

CUSTOM BUILD HIGHLINE 05 - JOINING A SQUARE OR RECTANGLE WITH 90° JOINERS

D. PITCHED CEILING SUSPENSION (REQUIRES ANGLED SUSPENSION WIRE)

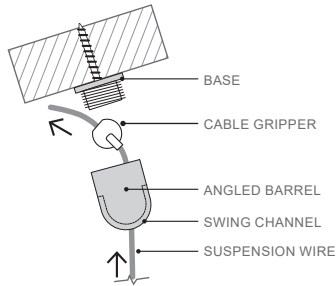

1. Position suspension wires to desired location (maximum distance of 3 metres between wires). Unscrew base from angled barrel and screw mount base into suitable ceiling substrate.
2. Thread suspension wire through angled barrel swing channel and feed through cable gripper.
3. The cable can be pulled upwards through cable gripper and it will prevent cable from moving backwards. The button on cable gripper can be pushed in to release cable back through.

4. Which cable firmly gripped, allow cable gripper to sit in angled barrel. Align the excess wire with the exit notch space in the base and rescrew the angled barrel onto base.
5. To ensure the cable hangs freely, the swing channel should end up aligned to the ceiling slope, allowing the suspension wire to hang straight down.
6. Thread the Y cable feet into the luminaire suspension channels.
7. Thread the unused suspension wire end into the Y cable gripper and out through the excess cable outlet.
8. Use Y cable gripper to adjust suspensions: Suspensions can be shortened by pulling the cable through excess cable outlet. To lengthen, press adjustment button inwards to release the wire.
9. Excess suspension wire can be cut off once luminaire is installed at the correct height.

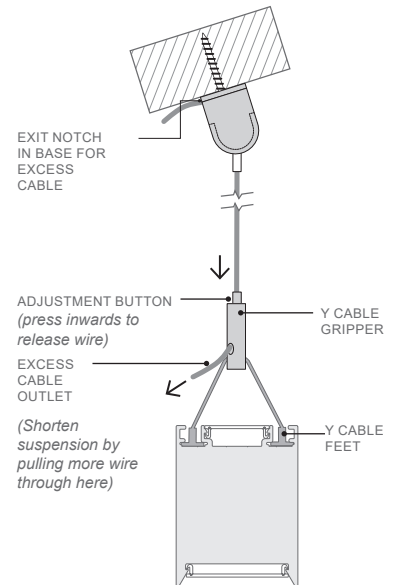

E. CEILING ROSE/CABLE BASE (FOR POWER FEED) INSTALLATION

Ø80MM RECESSED MOUNT INSTALLATION

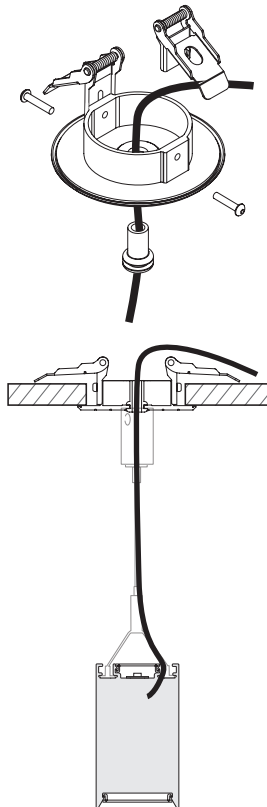

1. Select appropriate ceiling location for cable base - should be above luminaire and where the power feed cable can connect to the LED driver/mains power.
2. Drill Ø65mm hole in ceiling for face plate.
3. Connect spring clips to face plate sides using 2 × HY16 screws provided.
4. Ensure grommet is fitted into the face plate and then thread the power feed cable through centre and into ceiling.
5. While holding the spring clips in vertical (up) position, insert the face plate into the ceiling hole. The spring clips will snap back to the horizontal position as soon as they are released and will secure the cable base in place.

Ø80MM SURFACE MOUNT INSTALLATION

1. Select appropriate ceiling location for cable base - should be above luminaire and where the power feed cable can connect to the LED driver/mains power.
2. Drill hole in ceiling for power feed cable.
3. Position and screw the surface mount ring onto ceiling using the top four mounting holes, ensuring the drilled ceiling hole is aligned centrally.
4. Ensure grommet is fitted into the face plate and then thread the power feed cable through centre.
5. Thread the power feed cable through the ceiling hole.
6. Fit the face plate into the surface mount ring. Rotate face plate until the side screw holes align, then secure with 2 × HY16 screws provided.

