

ELEMENT 62

The Element 62 model is used for several different mounting types. When ordering Element you will have chosen your mounting type and your luminaire(s) will be designed for that purpose.

Make sure you refer to the specific installation guide for your luminaire installation type.



INSTALLATION IS TO BE DONE BY REGISTERED ELECTRICIAN IN COMPLIANCE WITH LOCAL STANDARDS

NOTE: TWO PEOPLE ARE REQUIRED FOR INSTALLATION

STANDARD CEILING MOUNT

For installing multiple modules read in conjunction with page 2.

1. The ceiling mount extrusion (FIG 1.1) is included with all surface mounted luminaire and is designed be screwed fixed directly to the ceiling. The standard option includes a 1m power feed which enters/exits the Luminaire at the top 185mm from the end.
2. Screws should be drilled in through the central channel in suitable locations with structural ceiling support (FIG 1.2 & FIG 1.3).
3. Ensure ceiling mount extrusion is level.
4. Use a **minimum of 3 screws per ceiling mount extrusion** (up to 3metres length). More screw locations may be required depending on the ceiling type.
5. The luminaire power cable can be run inside the Ceiling Mount Extrusion channel to reach your ceiling power connection location shown in FIG 1.4, before being wired in directly:

A) If ceiling power connection is located at the power feed end of the luminaire the Ceiling Mount Extrusion can be shortened by ~30mm to allow ceiling access or a hole drilled.

B) If ceiling power connection is not at the power feed end, a hole can be drilled through the Ceiling Mount Extrusion to allow cable exit. Grommets are required for any drilled hole to avoid cable damage (not included).

6. If diffuser is pre-installed, remove to reveal pre-drilled screw fixing points. FIG 1.5 shows approx screw locations.
7. The luminaire can now be clipped into ceiling mount extrusion. The Ceiling Mount Extrusion can help support the luminaire while the final screw fixing are made (FIG 1.2).
8. Tighten up each pair of these screws to secure the luminaire to the ceiling mount extrusion FIG 1.2 & FIG 1.5.
9. For multiple modules see page 2, from step 8 for diffuser installation.

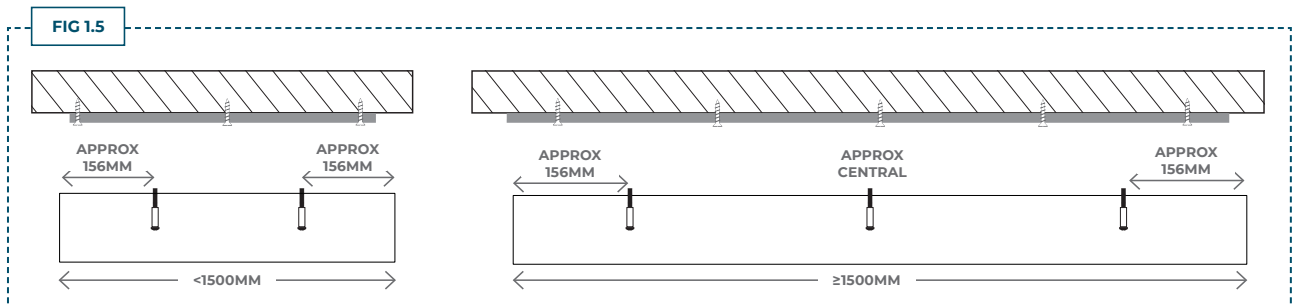
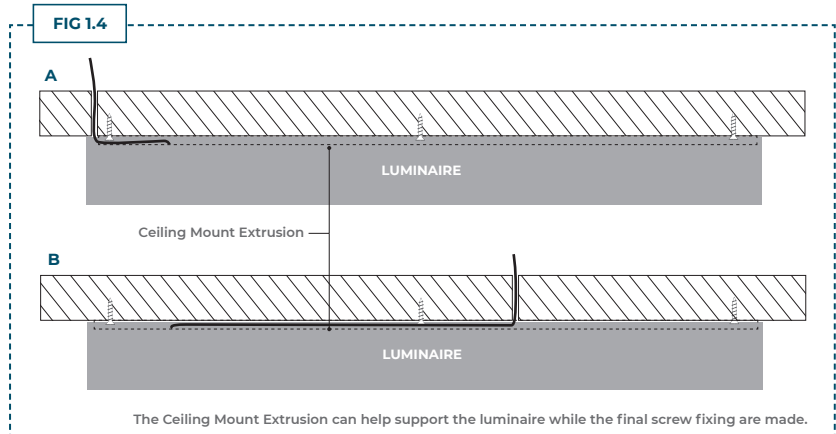
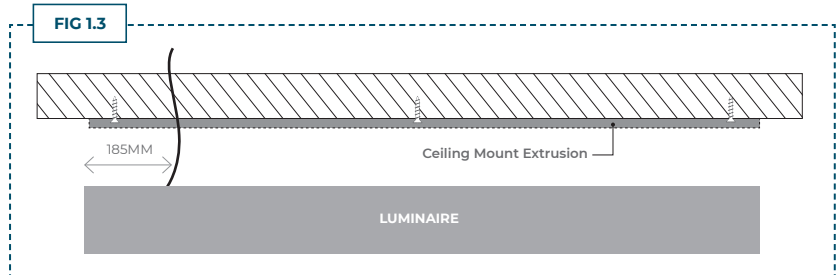
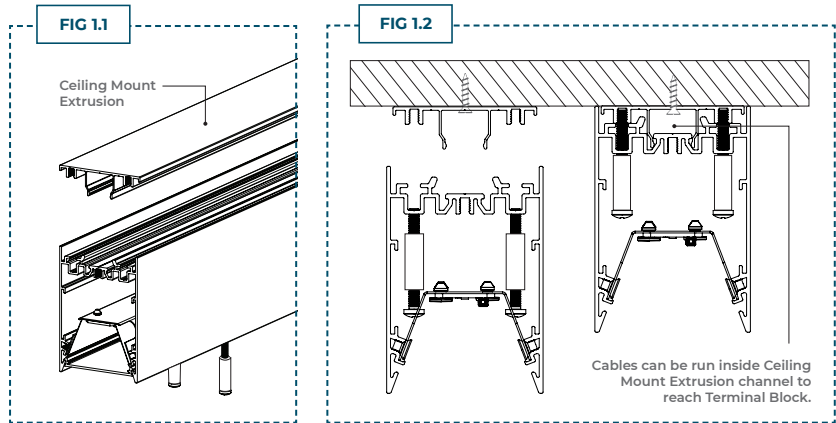

SCREWS ARE LOCATED AT APPROX LOCATIONS BASED ON INTERNAL COMPONENTS. THE REFLECTIVE FILM WILL BE PUSHED BACK TO SHOW SCREWS AND JOINS, REFLECTIVE FILM WILL NEED TO BE SLID ACROSS TO COVER HOLES ONCE MOUNTING IS COMPLETE & BEFORE DIFFUSER IS INSTALLED.

MODULE CONNECTION

For lengths up to 2540mm, we produce the luminaires from a single piece of aluminium. Lengths greater than or equal to 2680mm consist of several modules that can be easily connected on-site using joiners and pre-installed power connectors.

This modular approach simplifies accessibility during installation & helps reduce freight costs.



Feed & End modules used for lengths ≥2680mm
 Mid module used for lengths ≥5065mm
 Long lengths may have several mid modules.

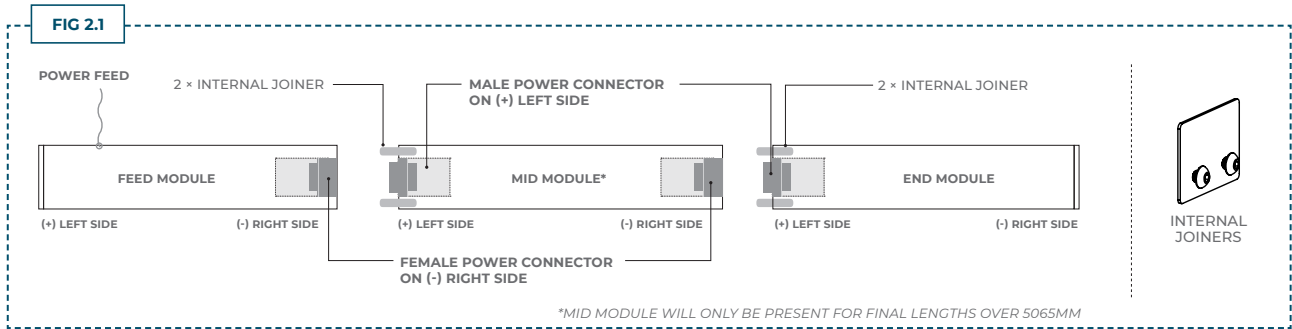

LAYOUT MODULES

1. Luminaire modules can be connected while resting on the ground/flat surface OR one at a time while being mounted.

For longer lengths Bright Light strongly recommend connecting modules one at a time (starting with power feed) and mounting each before adding the next.

The ceiling mount extrusion can be prefixed, then luminaires modules clicked into ceiling mount extrusion and slid along to meet up with previously installed modules and make electrical and mechanical joins. Refer to page 1 for Ceiling Mount Extrusion Installation.

2. Clear enough space to lay out full luminaire in the correct order as per FIG 2.1. Ensure surface is clear to avoid scratches.

ELECTRICAL CONNECTION

3. The electrical power connectors are built-in at joins between modules. Power connectors match female to male as shown in FIG 2.1. These will be aligned and connected at the same time as the mechanical joiners.

MECHANICAL JOINERS

4. Each join will have a set of internal mechanical joiners which come pre-mounted in the mid (if present) and end modules.
5. Internal joiners require screw access from below (diffuser side). While connecting, luminaire modules should be aligned & firmly held together while the joiner screws on either side are tightened.
6. Step 5 will need to be repeated for all joins.
7. Refer to Page 1 for installation using ceiling mount extrusion - standard.

DIFFUSER (Only fit once installation is completed)

8. Replace or insert diffuser. Measure luminaire, then trim diffuser to full luminaire length minus 10mm.
9. Luminaire end caps have a ledge with 5mm space underneath for the diffuser to prevent light bleed. Slot one end of diffuser under end cap ledge, then run along luminaire pressing diffuser in on both sides to achieve a flat surface. This is easier if one person hold and unrolls the diffuser and one person presses it into place. If pushed in too much, lift out section and press in again gently. When approx 200mm from the end of luminaire, gentle bend the diffuser over to allow the insertion of the end under the end cap ledge, then carefully press remaining diffuser in to create a flat surface.



(MIN. 2 PEOPLE REQUIRED)