

SURFACE MOUNT OR SUSPEND

BASELINE 06

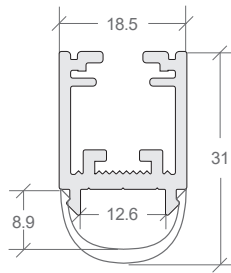

BASELINE 07

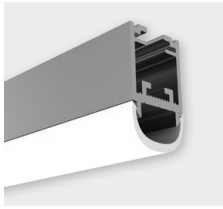
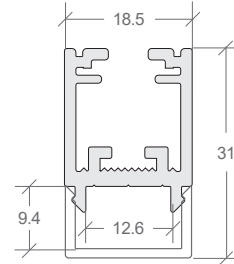
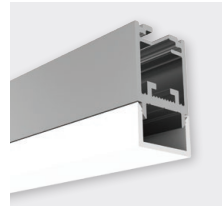

SURFACE MOUNTING

A. PROFILE INSTALLATION

1. Where joining profile, use the appropriate joiner and tighten grub screws.
2. Drill cable entry hole in profile for LED power feed. Thread LED power feed through hole, ensuring it is protected from sharp profile edges e.g. heatshrink or similar.
3. Use suitable screws (not supplied) to secure profile. Screws are required within 100mm each end, with even spacing in the middle.
4. Countersink screws and ensure screws do not stick up as this creates an uneven surface for the LED ribbon.

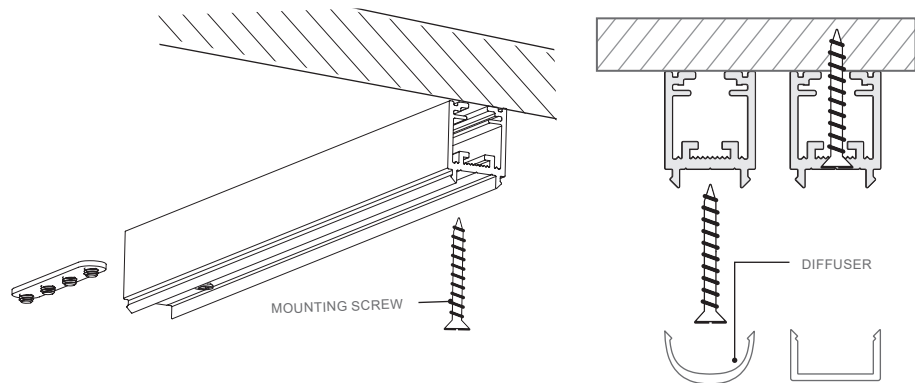

B. LED INSTALLATION

1. IMPORTANT - Before mounting LED strip, clean profile using an alcohol based cleaner.
2. Remove 3M paper from LED strip. Use the guide lines at the back of the profile as a guide to mount the LED strip.
3. Attach diffuser to profile by clicking in securely.
4. Secure end caps by pressing into place

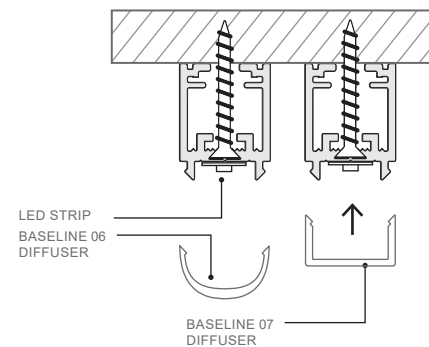
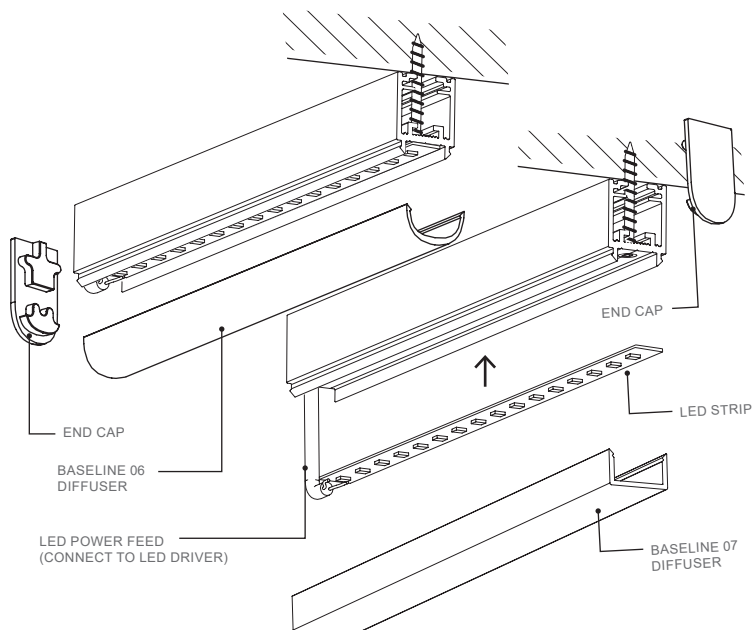

C. MAKE ELECTRICAL CONNECTION

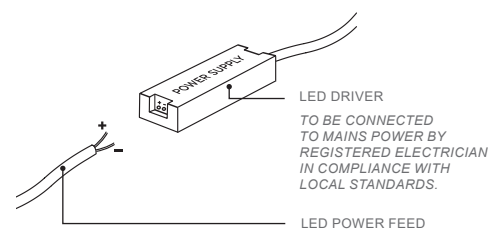

1. Connect LED power feed to LED driver.

SUSPENDED INSTALLATION

A. LED INSTALLATION

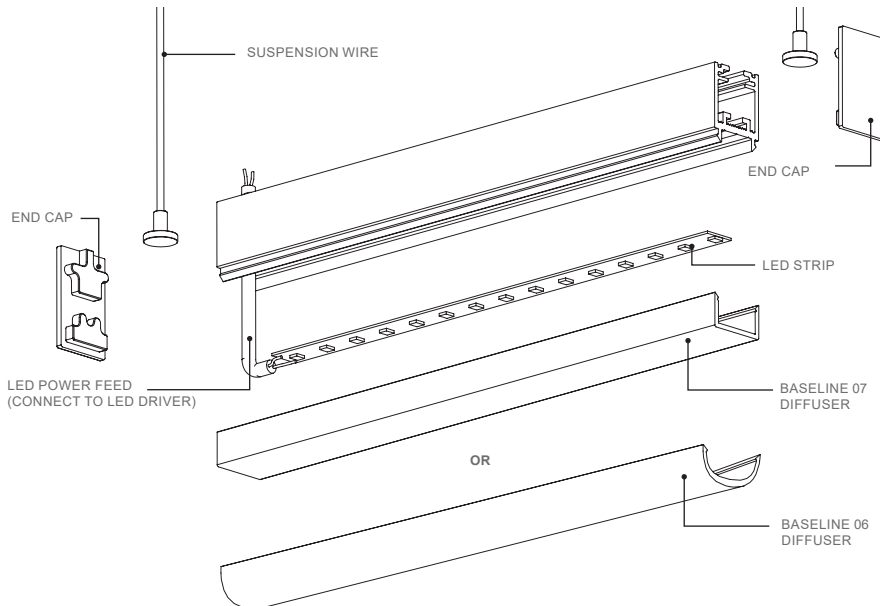

1. If joining, use the appropriate joiner (straight / corner / vertical to horizontal) and tighten grub screws.
2. Remove diffuser (if pre-attached).
3. Drill cable entry hole in profile for LED power feed.
4. **IMPORTANT** - Before mounting LED strip, clean profile using an alcohol based cleaner.
5. Remove 3M paper from LED strip. Use the guide lines at the back of the profile as a guide to mount the LED strip.
6. Thread LED power feed through profile hole, ensuring it is protected from sharp profile edges e.g. heatshrink or similar.
7. Attach diffuser to profile by sliding or clicking in securely.

B. PROFILE INSTALLATION - SUSPENSION WIRES

1. Slide suspension wires into suspension channel (maximum distance of 2 metres between wires).
2. Unscrew cable gripper from barrel base and use suitable screw (not supplied) to secure barrel base to support.
3. Thread suspension cable through cable gripper, barrel base and out cable hole, then rescrew cable gripper.
4. **To adjust cable length:** While one person supports the profile, press the cable gripper button inwards and either tighten; by pulling excess cable up through cable hole or release; by pulling excess cable back down.
5. Suspension wires can be cut down to length once installed.

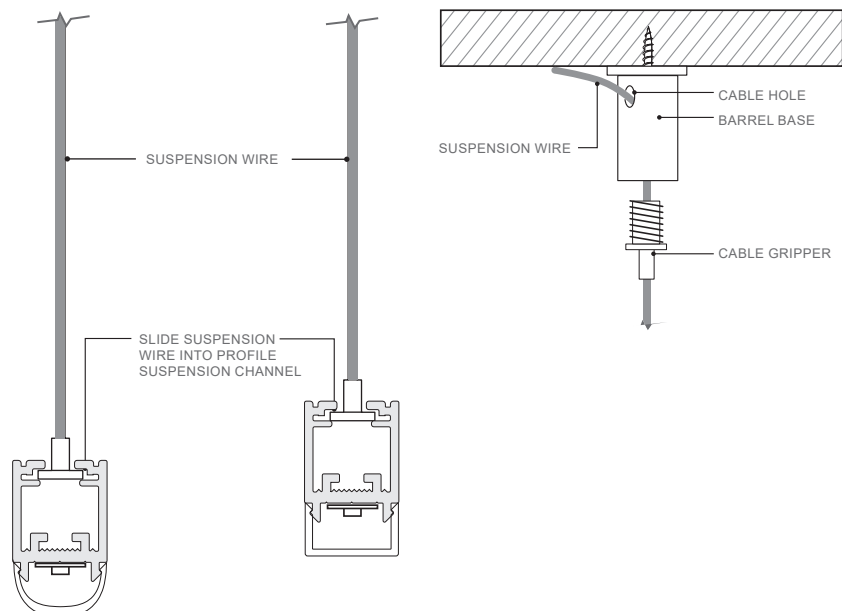

SUSPENDED

C. CEILING ROSE/CABLE BASE (FOR POWER FEED) INSTALLATION

Ø80MM RECESSED MOUNT INSTALLATION

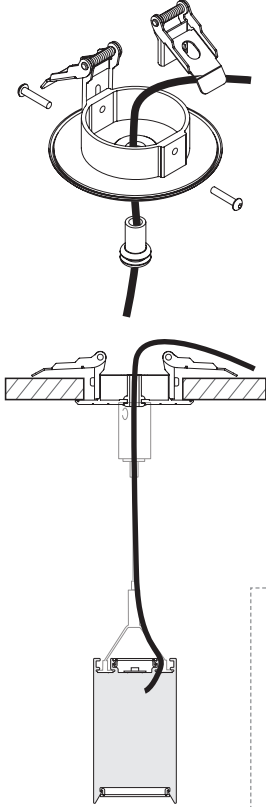

1. Select appropriate ceiling location for cable base - should be above luminaire and where the power feed cable can connect to the LED driver/mains power.
2. Drill Ø65mm hole in ceiling for face plate.
3. Connect spring clips to face plate sides using 2 × HY16 screws provided.
4. Ensure grommet is fitted into the face plate and then thread the power feed cable through centre and into ceiling.
5. While holding the spring clips in vertical (up) position, insert the face plate into the ceiling hole. The spring clips will snap back to the horizontal position as soon as they are released and will secure the cable base in place.

Ø80MM SURFACE MOUNT INSTALLATION

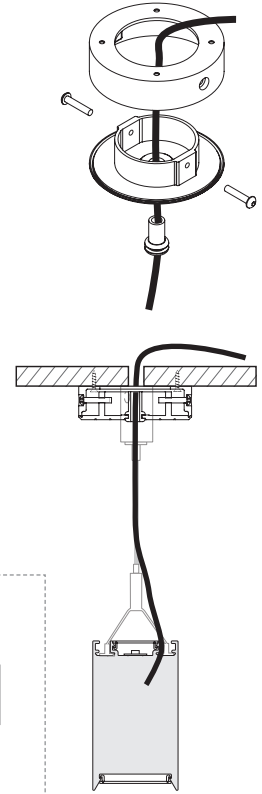

1. Select appropriate ceiling location for cable base - should be above luminaire and where the power feed cable can connect to the LED driver/mains power.
2. Drill hole in ceiling for power feed cable.
3. Position and screw the surface mount ring onto ceiling using the top four mounting holes, ensuring the drilled ceiling hole is aligned centrally.
4. Ensure grommet is fitted into the face plate and then thread the power feed cable through centre.
5. Thread the power feed cable through the ceiling hole.
6. Fit the face plate into the surface mount ring. Rotate face plate until the side screw holes align, then secure with 2 × HY16 screws provided.

Ø38MM MINI CABLE BASE INSTALLATION

1. Screw mount base in desired location - should be above luminaire and where the power feed cable can connect to the LED driver/mains power.
2. Drill out cable hole in ceiling, then thread cable through face plate and through base into ceiling space for electrical connection.
3. The small locking pin in the base can be tightened to gently grip the cable.
4. Fit face plate over base (held in place by magnet).

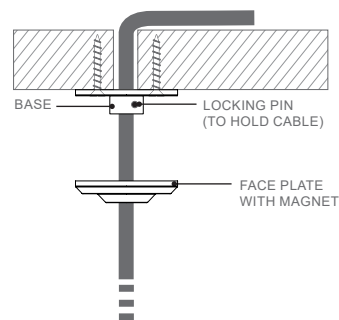

D. MAKE ELECTRICAL CONNECTION

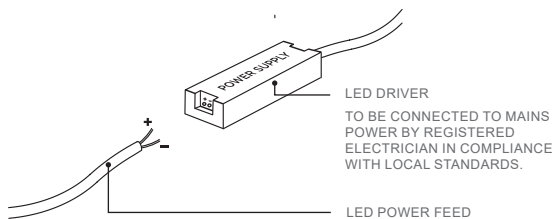

1. Connect LED power feed to LED driver.