

LOWLINE 04

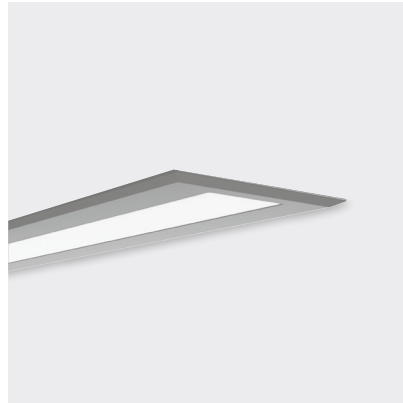

DIMENSIONS

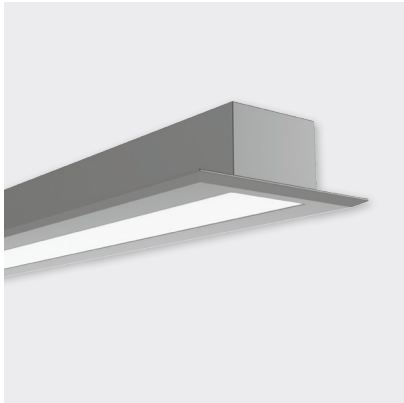
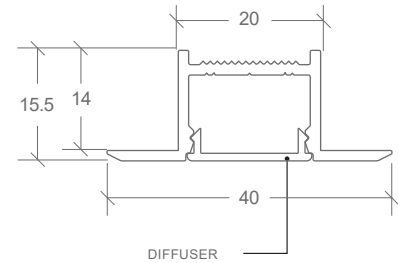

A. PROFILE REBATE CHANNEL INSTALLATION

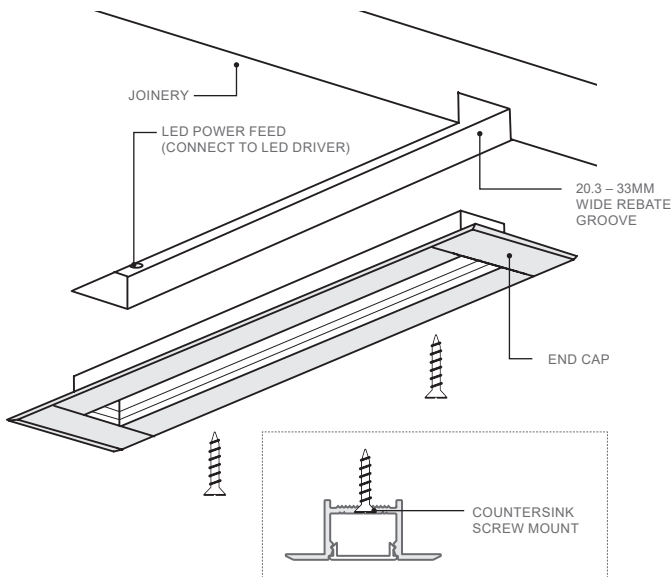

1. If diffuser is fitted in profile remove it by peeling out.
2. Secure end caps by pressing into place.
3. Router out a channel for recessed LED profile. The Lowline 04 wider trim makes it more forgiving if the channel is not exact. Channel can be 20.3 – 33mm.
4. Drill cable entry hole in profile and joinery for LED power feed.
5. Countersink screw mount the profile with end caps into the rebate channel. *Ensure screws don't stick up as the LED Ribbon Strip requires a flush surface.*

D. MAKE ELECTRICAL CONNECTION

1. Connect LED power feed to LED driver.

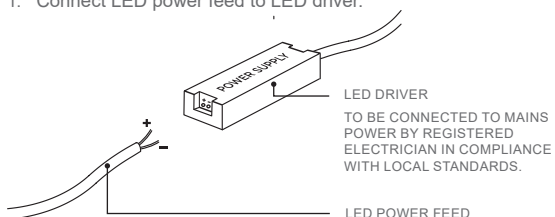

B. LED STRIP INSTALLATION

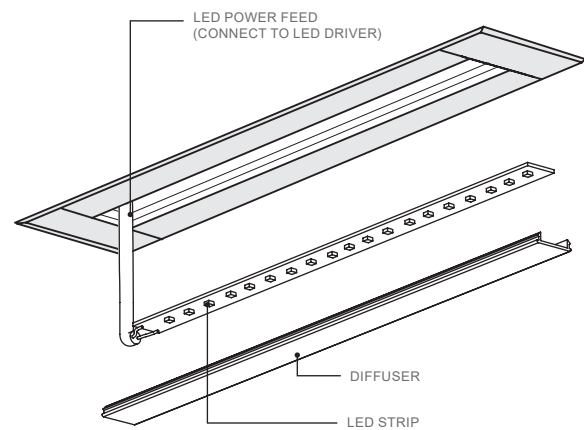

1. Thread LED power feed through cable entry hole, ensuring it is protected from sharp profile edges e.g. heatshrink or similar.
2. Connect LED power feed to LED driver.
3. **IMPORTANT** - Before mounting LED strip, clean profile using an alcohol based cleaner.
4. Remove 3M paper from LED strip to expose sticky surface and stick along centre of profile.
5. Attach diffuser to profile by clicking in securely.

C. SCREW MOUNT INSTALL DETAIL

