

3 × 3A REPEATER | BL-PC-RPT-4004

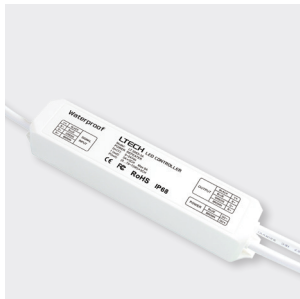

CODE
BL-PC-RPT-4004

OUTPUT CURRENT	MAX. LOADING	VOLTS
	45W	5V DC
3 × 3A channels (9A)	108W	12V DC
	216W	24V DC
OPERATING TEMP.	-20°C ~ +50°C	
INGRESS PROTECTION	IP68	
CONNECTION METHOD	200mm double insulated leads	
CONTROL	Requires controller with PWM output	
MAX. DISTANCE FROM POWER SUPPLY	Recommended under 10 metres <i>For specific projects contact Bright Light</i>	
DIMENSIONS	W35 × L163 × H28mm	
HOUSING	PVC casing	
MOUNTING	2 × mounting tabs	
WARRANTY	5 years	
COMPLIANCE		

DIMENSIONS

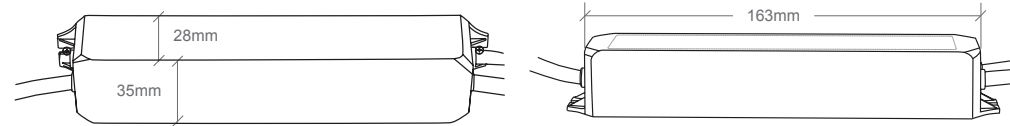

WIRING DIAGRAMS

1) Repeater as all connected to controller in parallel

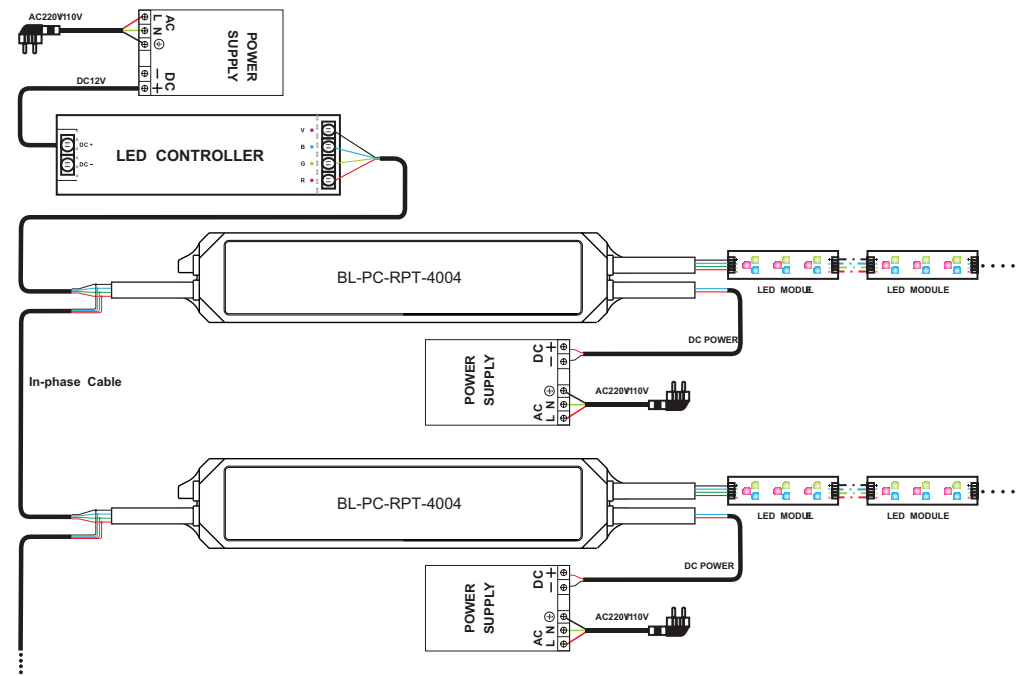

FUNCTION

- Used to expand the output of single colour, Tuneable white, or RGB ribbon strip controllers

ATTENTION:

- The product shall be installed and serviced by a professional electrician.
- This product is not waterproof & cannot be installed outdoors, use IP65 box if required for outside use.
- Good heat dissipation will prolong the working life of the repeater, please ensure good ventilation.
- Please check the output voltage of any power supply used complies with the working voltage of the LED product used.
- Ensure an adequate sized cable is used from the controller to the LED lights to carry the current, please also ensure the cable is secured tightly in the connector.
- Ensure all wire connections and polarities are correct before applying power to avoid any damages to the LED lights.
- If a fault occurs please return product to your supplier. Do not attempt to fix this product yourself.

3 × 3A REPEATER | BL-PC-RPT-4004

WIRING DIAGRAMS

2) DMX decoder connected to CV power repeater

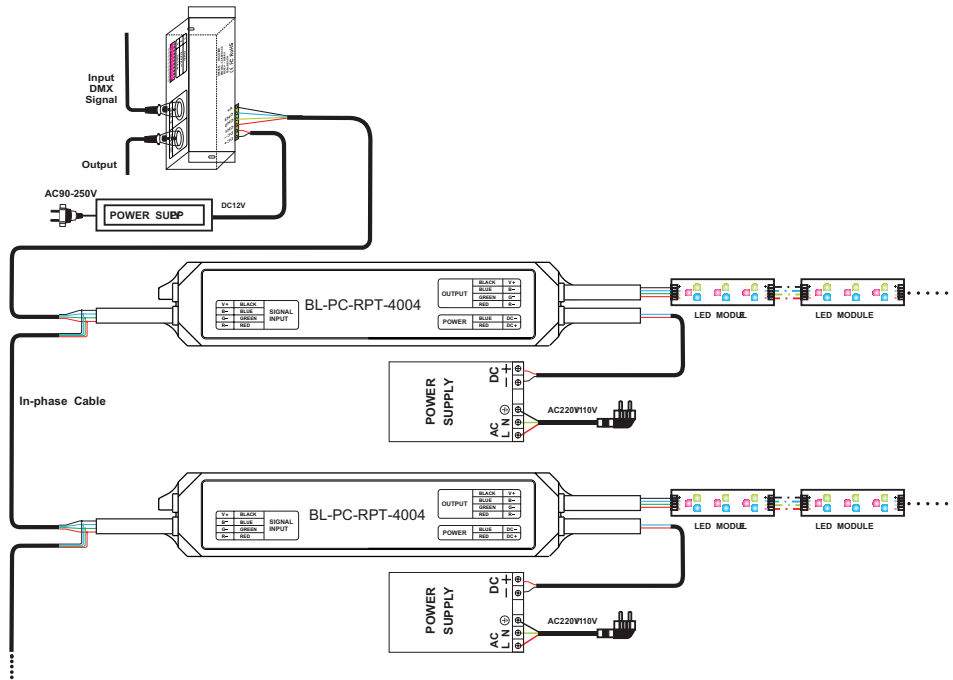

3) Power repeater connected to LED dimmer

