

LT-DMX-1809 DMX-SPI Signal Decoder Manual



Welcome to choose our DMX decoder, DMX-SPI signal decoder works to convert DMX512 digital signal to SPI (TTL) digital signal. It can control LED lights compatible with driving IC, and control every channel of the LED lights, realize the function of 0~100% dimming or editing all sorts of change effect.

DMX-SPI decoder are widely used in LED flashing word string light, LED dot light, SMD strip, LED digital tubes, LED wall light, LED pixel screen, Hi-power spotlight, flood light, etc.

1. Product Parameter:

LT-1809	
Input Voltage	DC5V~DC24V
Input Signal	DMX512
Output Signal	SPI (compatible with TM1803, TM1804, TM1809, TM1812, UCS1903, UCS1909, UCS1912, UCS2903, UCS2909, UCS2912, WS2811, WS2812 driving IC)
Decoding Channels	512 Channels/Unit
Output Grey Scale	256 levels/CH(8bit/CH)
DMX512 Connector	XLR-3, Green Terminal
Product Dimension	L125×W52×H40mm
Package Size	L135×W70×H50mm
Working Temperature	-30°C ~65°C
Weight (G.W.)	300g

2. Configuration Diagram:

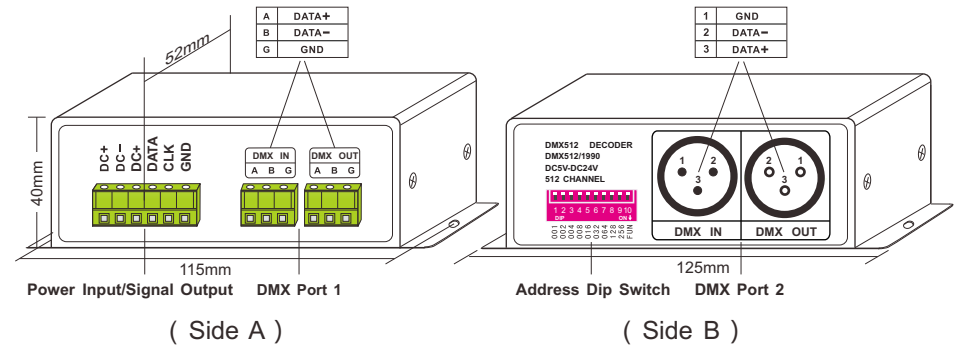

3. Output Port Definition:

No.	Silk Screen	Function
1	Power Supply Input Port	DC+
	DC-	DC5V-24V LED Power Supply Input
2	Output Port Connect Led	DC+
	DATA	LED Power Supply Anode
	CLK	Data Cable
	GND	Clock Cable(N/A)
		Ground Wire(DC-)

4. How to Set DMX Address Via Dip Switch:

1) Set DMX512 Original Address

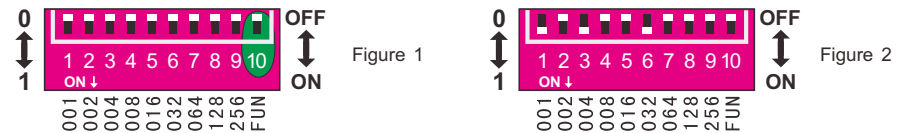

The Decoder enter into DMX control mode automatically, when receiving DMX signal.
Like figure 1: FUN=OFF is high speed(upward), FUN=ON is low speed (downward)

DIP	1	2	3	4	5	6	7	8	9	10
Address	001	002	004	008	016	032	064	128	256	high/low speed

Instructions

- The driving chip of this decoder has option for high and low speed(800K/400K), please choose the suitable speed according to the design of your LED lights, in most cases, it is high speed.
- DMX512 initial address is the total amount of the Dip switch 1-9, down dip switch to "ON" position, User can get its place value, Up dip switch to "OFF" position, Its place value is 0.

For example, Set initial address to 37

As figure 2, set the 6th, 3rd and 1st bit of the DIP switch downward to "1", the rest to "0", the total sum from 1 to 9 is 32+4+1, so the DMX512 initial address code is 37.

2) Testing function:

The DMX decoder will be entered into self control mode automatically without DMX signal input

DIP1	DIP2	DIP3	DIP4	DIP5	DIP6	DIP7	DIP8	DIP9
Red	Green	Blue	Yellow	Purple	Cyan	White	Jumping	Gradual change

Figure 3

Figure 4

DIP8/DIP9=ON: change mode. DIP switch1-7 is to realize 8 speed levels, 7 is the fastest levels while DIP switch 1-7=OFF: the speed is 0.

DIP1	DIP2	DIP3	DIP4	DIP5	DIP6	DIP7
Speed 1	Speed 2	Speed 3	Speed 4	Speed 5	Speed 6	Speed 7

As figure, when several DIP switches are on, subjected to the highest switch value, when all the DIP switches=ON, it's the color gradual in the test mode, 7 speed level.

5. Configuration Diagram:

1) LED Digital Strip Physical Conjunction Diagram.

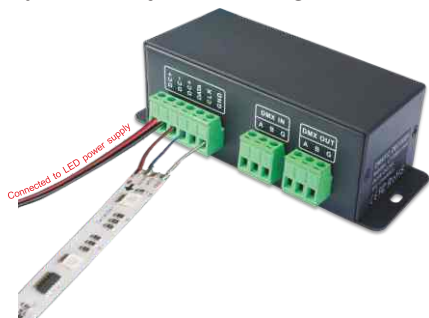

2) LED Wall Washer Conjunction Diagram.

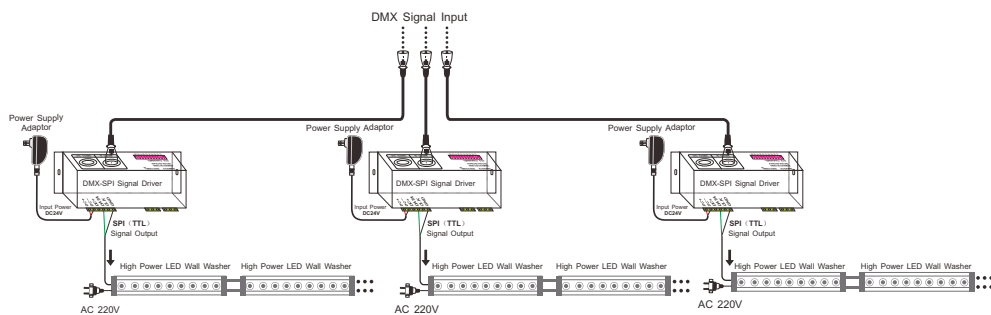

3) LED Digital Strip Conjunction Diagram.

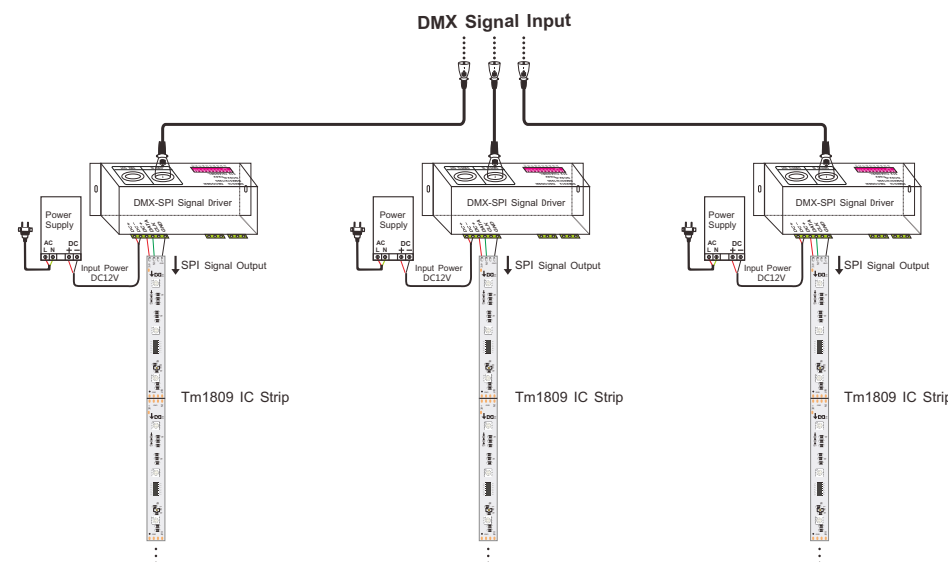

6. Attention:

- 1) The product shall be installed and serviced by a qualified person.
- 2) This product is non-waterproof. Please avoid the sun and rain. When installed outdoors please ensure it is mounted in a water proof enclosure.
- 3) Good heat dissipation will prolong the working life of the controller. Please ensure good ventilation.
- 4) Please check if the output voltage of any LED power supplies used comply with the working voltage of the product.
- 5) Please ensure that adequate sized cable is used from the controller to the LED lights to carry the current. Please also ensure that the cable is secured tightly in the connector.
- 6) Ensure all wire connections and polarities are correct before applying power to avoid any damages to the LED lights.
- 7) If a fault occurs please return the product to your supplier. Do not attempt to fix this product by yourself.

7. Warranty Agreement:

- 1) We provide lifelong technical assistance with this product:
 - A 5-year warranty is given from the date of purchase. The warranty is for free repair or replacement and covers manufacturing faults only.
 - For faults beyond the 5-year warranty we reserve the right to charge for time and parts.
- 2) Warranty exclusions below:
 - Any man-made damages caused from improper operation, or connecting to excess voltage and overloading.
 - The product appears to have excessive physical damage.
 - Damage due to natural disasters and force majeure.
 - Warranty label, fragile label and unique barcode label have been damaged.
 - The product has been replaced by a brand new product.
- 3) Repair or replacement as provided under this warranty is the exclusive remedy to the customer. LTECH shall not be liable for any incidental or consequential damages for breach of any stipulation in this warranty.
- 4) Any amendment or adjustment to this warranty must be approved in writing by LTECH only.
 - ★ This manual only applies to this model. LTECH reserves the right to make changes without prior notice.