



Gooseneck Chair Clamp

PAD-CHAIRPB - PAD-CHAIRPW

INSTRUCTION - MANUAL

CONTENTS:

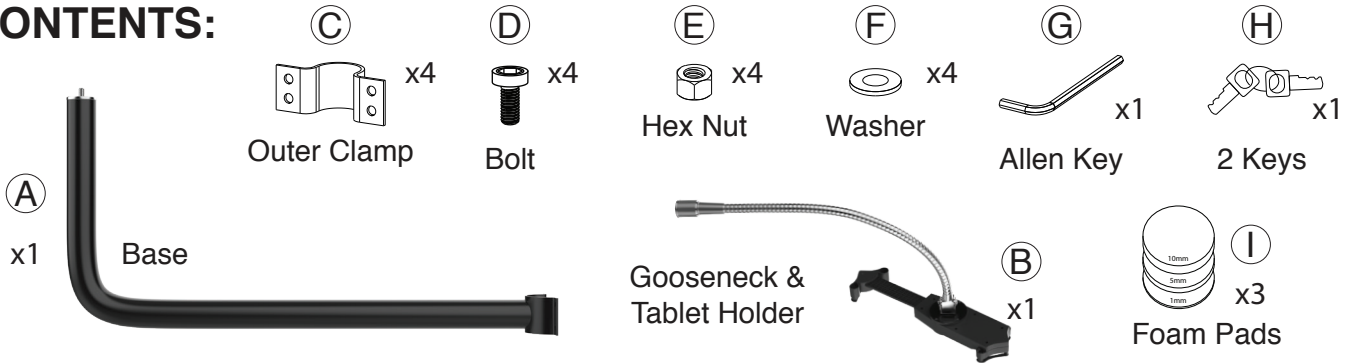

INSTALLATION:

1. Connecting Base with Gooseneck

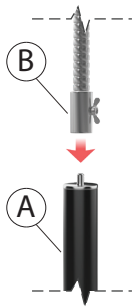

1A. Align the base (A) with the gooseneck (B).

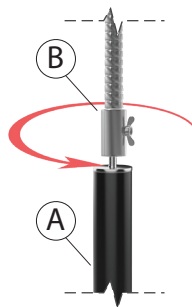

1B. While aligned, rotate the gooseneck's base (B) until completely secured.

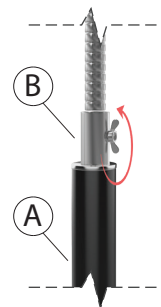

1C. Rotate butterfly knob to securely fasten gooseneck (B) to body (A).

2. Attaching Base to Chair

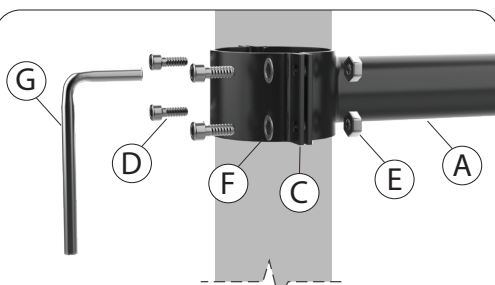

2A. Align both sides of the hoop (A and C) to the chair's cylinder.



2B. While holding the (4) Hex Nuts (B) in the back, align the Washers (F) and the (4) Bolts (D) with the holes. Use the included Allen Key (G) tool to screw the (4) Bolts until securely tightened.

3. Attaching Foam Pad to Tablet Holder

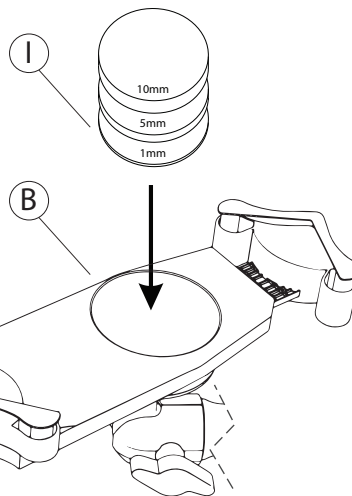

3A. Select the appropriate foam pad (I) according to the thickness of your tablet (or tablet in its case), then press adhesive side into center of the tablet holder.

Foam Pad Thickness:	Tablet Thickness:
1mm	0.67-1.06in / 17-27mm
5mm	0.51- 0.91in / 13-23mm
10mm	0.31- 0.71in / 8-18mm

- Use this table to determine the appropriate foam pad (B) to use with your tablet.
Note: sizes refer to total tablet size with or without a case

4. Inserting Tablet to Holder

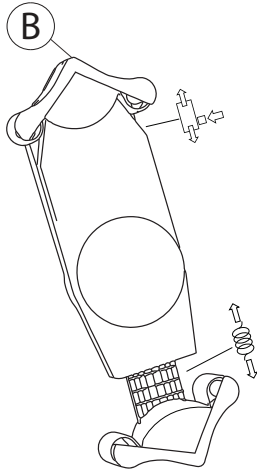

4A. Press quick release button on side of tablet holder (B) to release the adjustable end.

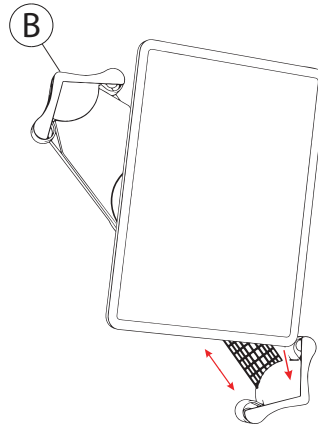

4B. Insert tablet corner against the spring arm. Push adjustable arm down against opposite corner (A). Be sure it is as snug as possible.

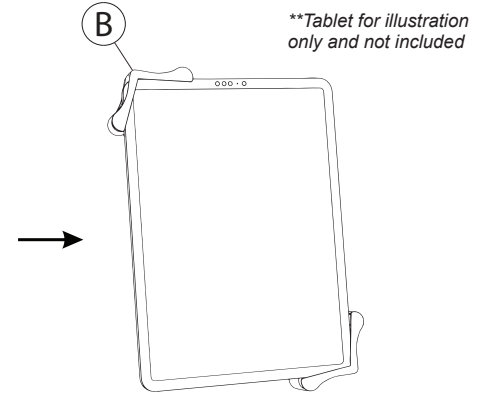

5. Adjusting the Gooseneck and Holder



5A. For landscape or portrait setups, rotate the holder (B) as shown above.

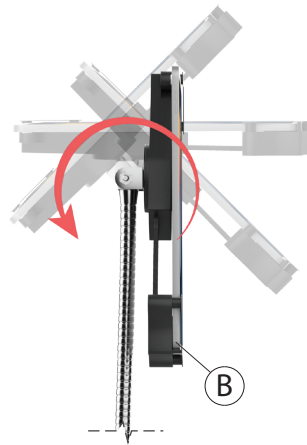

5B. For forward or backwards setups, rotate the holder (B) as shown above.

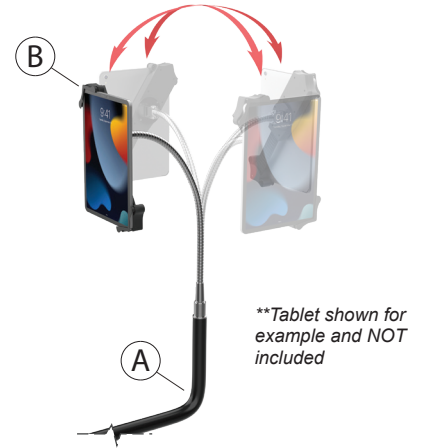

5C. For even more setups, rotate the base of the gooseneck (B) as shown above.