



Custom Flex Clamp Mount with Security Holder for Otterbox uniVERSE and Defender Series Cases

PRODUCT DATA SHEET



SKU:
➤ OTT-CFDCM

MOUNTING:

➤ Clamp Mount

HOUSING:

➤ Metal Body

WEIGHT:

➤ 1.3 Lbs



DIMENSIONS:

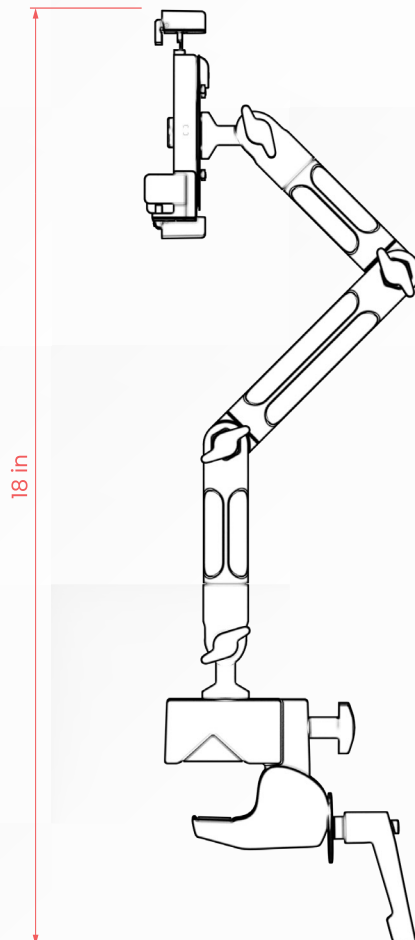

FEATURES:

- Anti-theft locking security holder
- Embedded magnets for guided connection
- Adjustable holder arms to fit a wide range of tablets
- Heavy-duty clamp grips tabletops or poles
- Two 180-degree rotating joints
- Two omnidirectional ball sockets at base and headpiece
- Allows portrait and landscape displays
- Built-in k-slot on holder sides for anchor options
- VESA Compatible 75x75 and 100x100 mm mounting plate
- Galvanized steel security cable anchors stand to table, desk, or another permanent fixture
- Compatible with all Otterbox uniVERSE and Defender Series

COMPATIBILITY:

- Otterbox uniVERSE and Defender cases



ANTI-THEFT SECURITY HOLDER



TILT ADJUSTABLE



CABLE MANAGEMENT