

EcoQube™

by AQUA DESIGN INNOVATIONS

 Like Aqua Design Innovations

 Follow @DesignADI

Our Story

Our names are Eric Suen and Kevin Liang. We're UC San Diego students and aquarium geeks who met in high school and instantly became intrigued by planted aquatic ecosystems.



After working in the aquarium industry for a few years, we eventually started our own online aquarium store while selling shrimp out of a garage in San Francisco.

As we got older, we saw the bigger challenges humanity as a whole faces in terms of food and water shortages and wanted to use our knowledge of aquariums to find a solution.



1,500,000 people die of hunger every year.

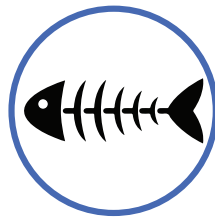

1.2 trillion gallons of waste water are dumped in the U.S. annually, harming the environment.



5,000 people lack clean water daily.

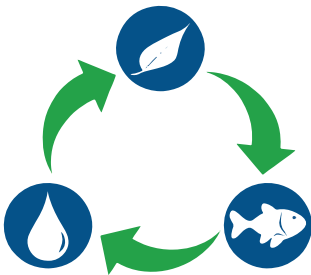

Aquaponics, a method of raising crops and fish together in a recirculating system, grows food 30 to 50 percent faster, using far less space and 90 percent less water.

In 2013, we launched our first product, the EcoQube — a desktop ecosystem designed to bring the practical concept and beauty of aquaponics into our everyday lives!



EcoQube™

A desktop ecosystem that uses Mint or Basil to filter water

QUICK START GUIDE

To save trees, we only included essential information here. For FAQs, please visit adventures.net/faq. For international EcoQube owners without seeds or plant medium, please visit adventures.net/international.

1. Remove Aquaponics Filter, aquarium, and electricals from packaging.
2. Place Aquaponics Filter on aquarium and add "Grow" soil* or "Origin" sand to aquarium along with any plants* or decorations*.
3. Gently pour conditioned water over soil* or sand, filling aquarium all the way to the rim. Minor debris and cloudiness is normal and will clear up within 3 days.
4. Insert net pot (plant medium with seeds included inside) into slot in filter cover with engraved ADI logo facing forward.

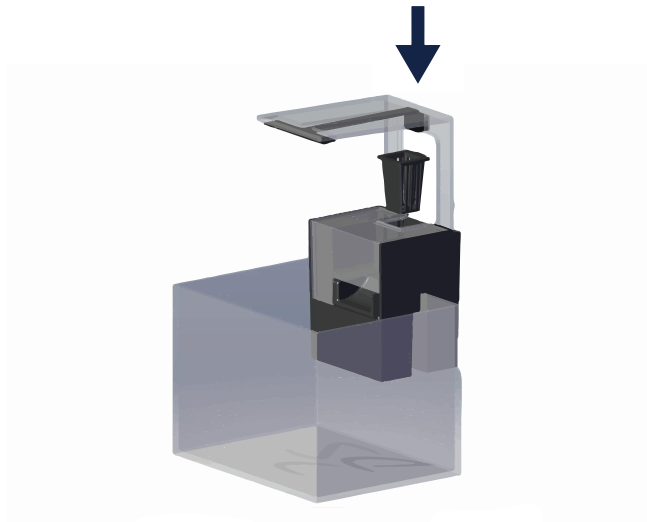

*Denotes Sold Separately

5.

Plug power supply cord into 110V AC- 240V AC (international) outlet and connect it to single end of 3-way splitter. Connect 3 ends to pump, LED light, and UV sterilizer*. Run water through filter.



Power Supply

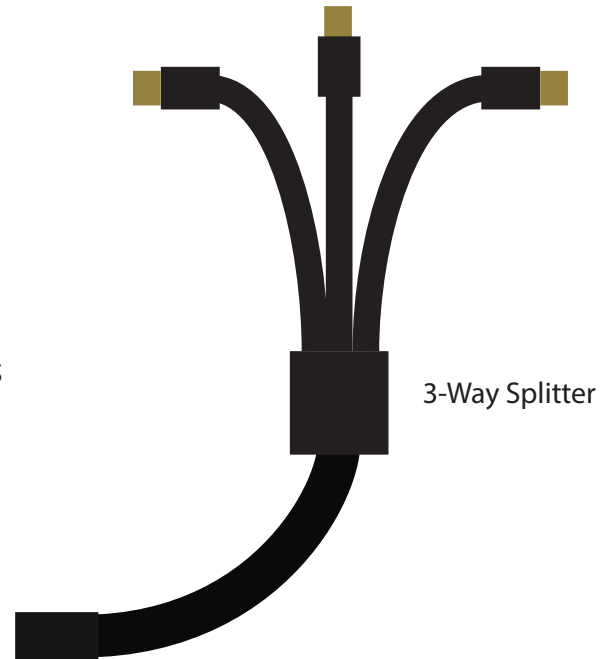

6.

Press  once to turn on LED light.

Leave white lights on for 6-8 hours per day. Plant should start sprouting within 2 weeks.



Press for Changing Colors



1st Press: White Lights On
2nd Press: Lightning
3rd Press: Cloud Cover
4th Press: Off

7.

Wait until plant is at least 1 inch tall (about 3 weeks old) before introducing any fish to allow ecosystem to mature. Place EcoQube in a warm, dark area to help accelerate this process.

8.

Turn on UV sterilizer*:



For Cloudy Water: Press once for 24-hour sterilization (light will appear red).

For Regular Maintenance: Press a second time for 2 hours of sterilization per day (light will appear green).

*Denotes Sold Separately

EcoQube™

A desktop ecosystem that uses Mint or Basil to filter water

MAINTENANCE GUIDE

The EcoQube is a desktop ecosystem designed for the lowest maintenance possible so that you can spend more time enjoying and less time cleaning. However, proper care is essential to ensure a healthy and functioning ecosystem.

Notes of Caution:

- Always keep pump inside filter (highlighted) submerged in water when filter is running.
- Always unplug filter first before lowering water level below its water chute or removing it from aquarium.
- Don't consume plant grown from filter. Many chemicals used in aquariums can be extremely harmful if consumed.

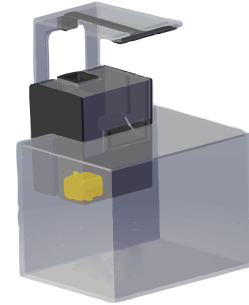

How to Maintain Your EcoQube:

- Wait at least 3 weeks before introducing any fish to aquarium. Start off with 2 small fish (white cloud minnows or zebrafish recommended) and slowly add more as plants grow. Limit each aquarium to 5 small fish to avoid overcrowding.
- Feed only what fish can eat in 10 seconds 1-2 times per day.
- Don't remove filter cover until plant has grown in or else plant will fall and roots will rip.
- Raise LED light (holding side without wire) as plant grows. Trim leaves if plant no longer fits beneath light at its highest setting. Always be sure to leave at least one set of three leaves intact when trimming.
- Add more plants (Java Ferns and Anubias recommended) inside aquarium to promote natural filtration.
- Detoxify 2 gallons of water with 1 ml of "Refine" water conditioner.
- Top off aquarium with RO/DI water or bottled water only to ensure there are no extra minerals in water. Filter is not compatible with salt water since it was designed for plants like Basil and Mint that can only grow with fresh water.
- Make sure water level doesn't fall below water chute on filter. Replenish evaporated water at least once a week. Don't stir soil or sand when adding water.
- If filter gets clogged, remove filter cover, take out sponge, and rinse sponge in conditioned water. Remove any debris on bottom of filter and place sponge back into filter.

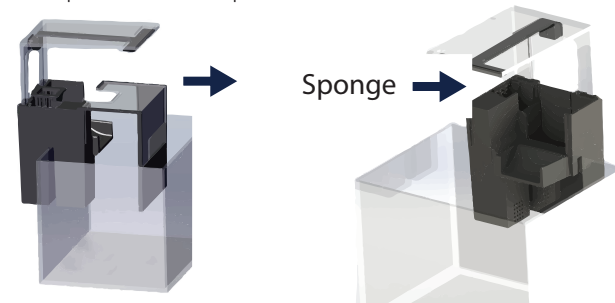

- For extra clarity and cleanliness, turn on UV sterilizer* when introducing new fish to aquarium to get rid of microbes, unwanted bacteria, and algae.

*Denotes Sold Separately

The Aquaponics Cycle

