

O O O

BASKETBALL HOOP

PROVIDED



HEX BOLTS X 4

(A)



WALL ANCHORS X 8

(B)



SCREWS X 8

(C)

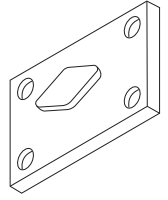

MOUNTING PLATE X 2

(D)

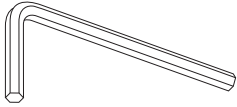

ALLEN KEY X 1

(E)

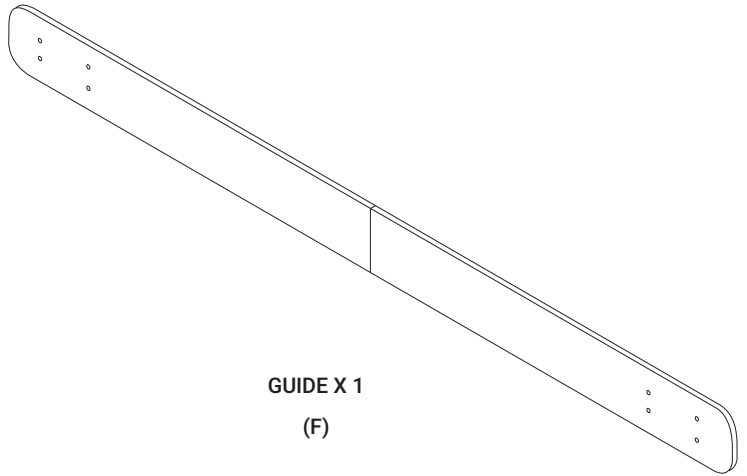

GUIDE X 1

(F)

NOT PROVIDED

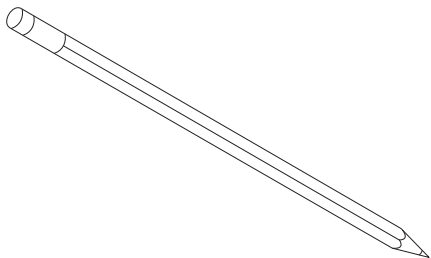

PENCIL

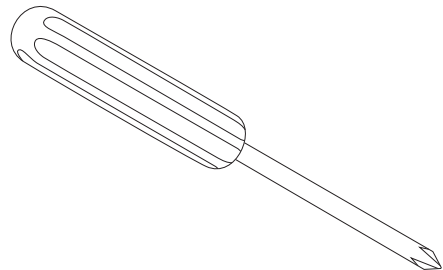

SCREWDRIVER

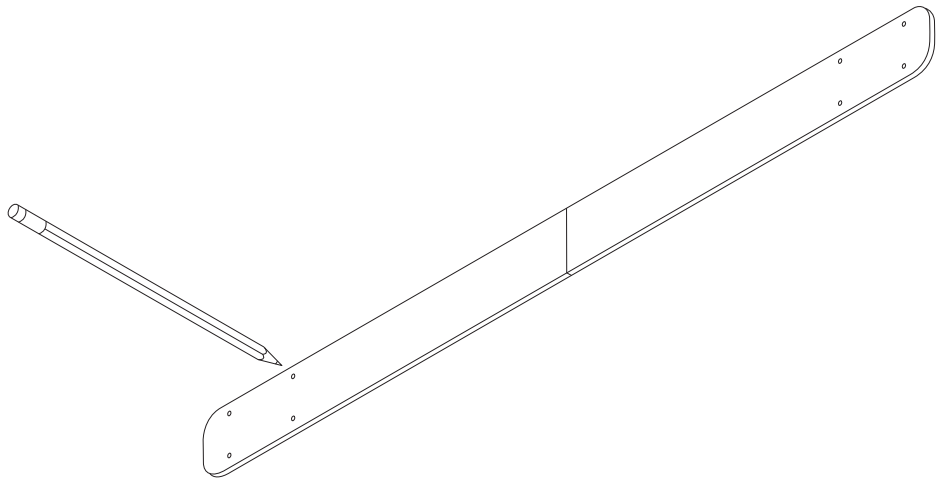
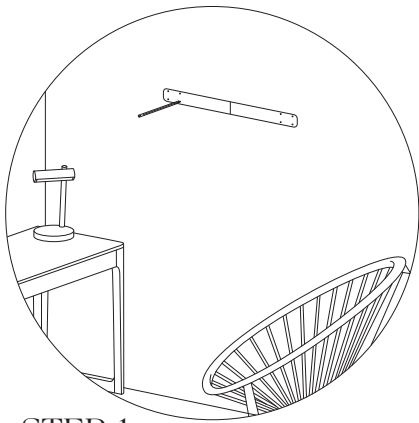

STEP 1

Begin installation by using the provided Guide (F) to mark the Wall Anchor (B) locations.

F

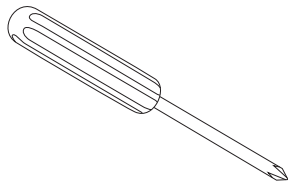

STEP 2

Using a Philips head screwdriver, drive the Wall Anchors (B) into the wall at the marked locations.

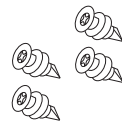

B

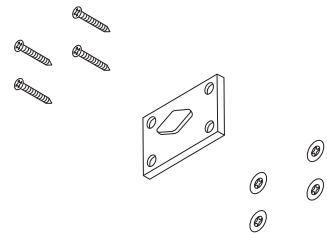
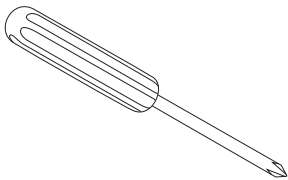

STEP 3

Drive the screws (C) through the Mounting Plates (D) and into the wall anchors.



C

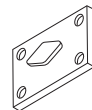

D



B

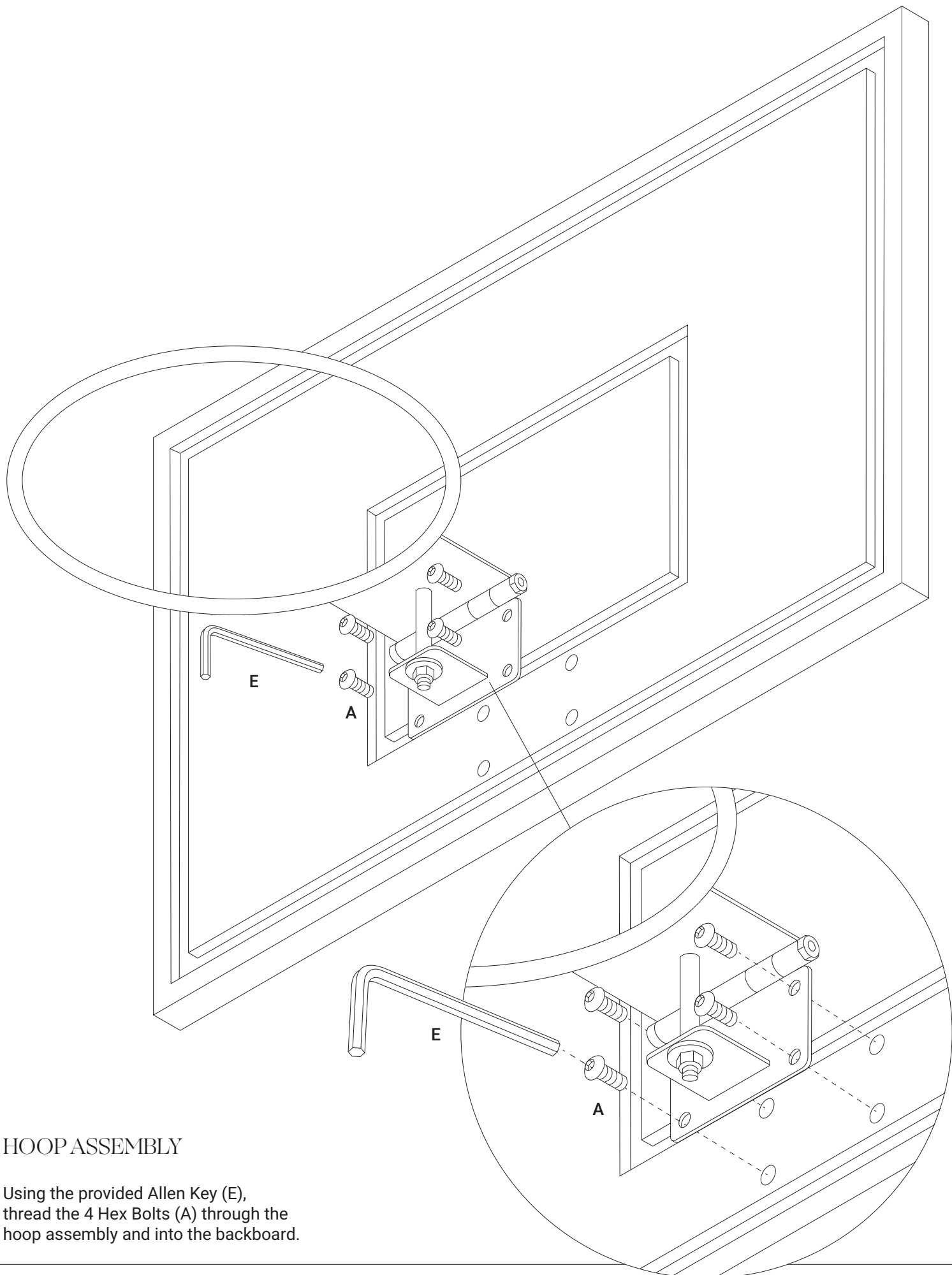

HOOP ASSEMBLY

Using the provided Allen Key (E),
thread the 4 Hex Bolts (A)
through the hoop assembly and into the backboard.

HOOP MOUNTING ON WALL

Slide the backboard down onto the mounting plates.

Ensure the mounting plates are fully seated as illustrated below.

