

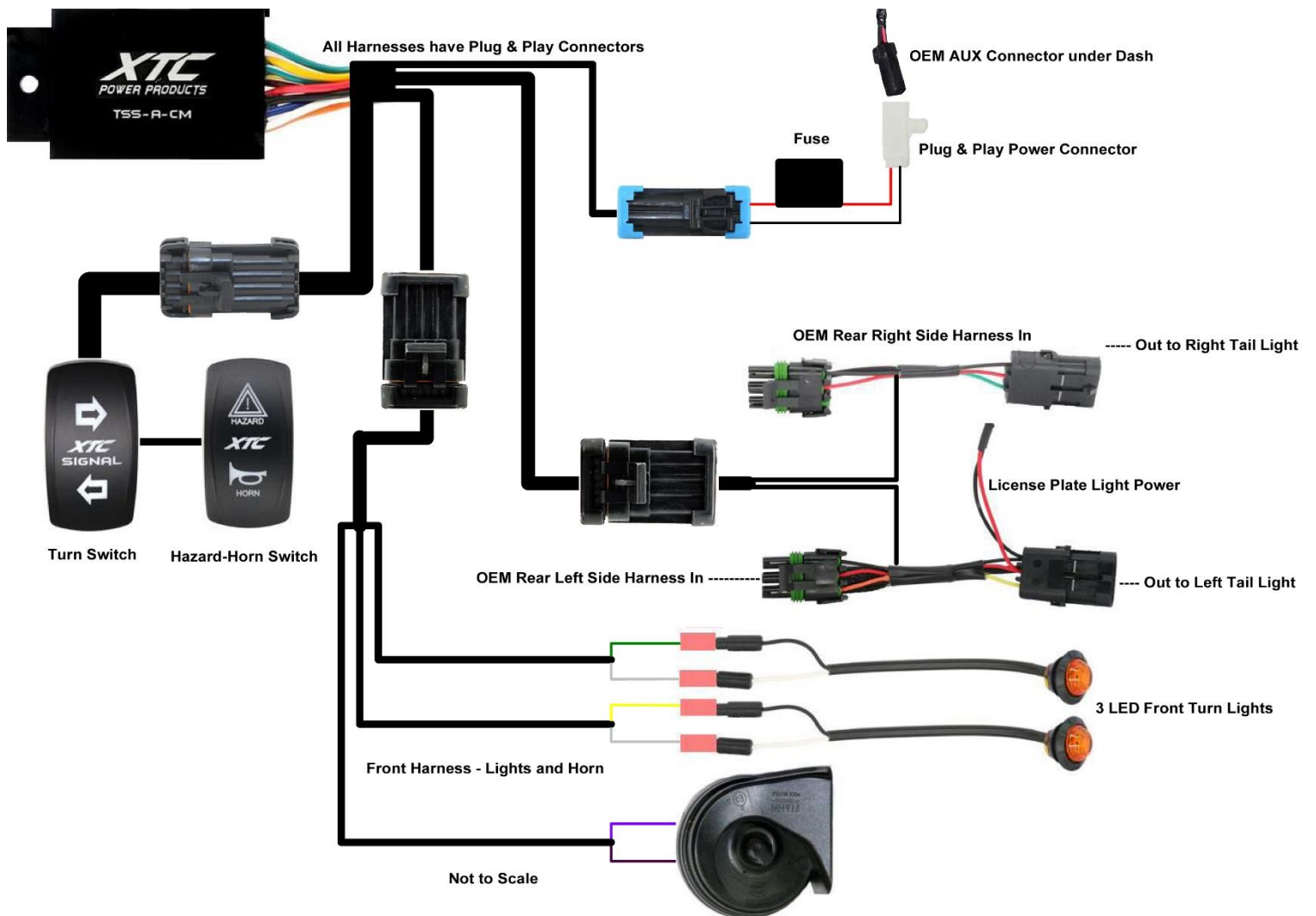

Can-Am Maverick R Self-Canceling Turn Signal System

Thank you for purchasing XTC Power Products Automatic Self-Canceling Turn Signal System. Our Easy Install Turn Signal System is unique from the other kits on the market. This kit is from our Plug & Play™ product line, no wires to cut, no crimping that Plugs into the AUX Power Connector under the dash and plugs into the OEM Taillight Harness, utilizing the brake lights as Brake and Turn Signals.



Please read the instructions fully and familiarize yourself with the components before starting the install.

1. **Remove** the driver side center kick panel and center cup holder. Remove the front hood by pulling up on the rear and un-clipping then slide forward as shown.



2. **Install Rear Harness** – Un-roll the rear harness, attach the rear extension if not already attached. Starting at the center console at the cup holder, push the two connectors with the yellow wire through the fire wall towards the driver's side. Inside the rear wheel well at the fire wall is a connector with a chrome hook on it, un-plug and plug the yellow wired connector in-line. Run the connectors with the green wire to the right/passenger side rear wheel well, un-plug the top connector and plug the harness in-line, there is a red and black wire for power to an optional license frame light.

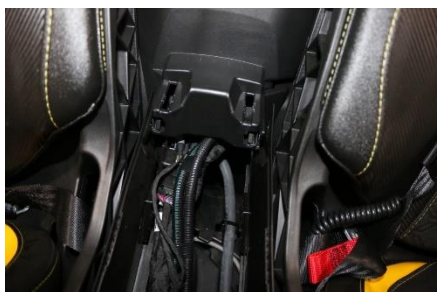

3. **Run the rear extension** – under the dash cover is the ECU and Busbar power posts. Un-plug the extension cable from the rear harness, un-roll and run the female down the fire wall behind the ECU to the center panel, follow through the center to the previously installed rear harness and plug in.



WARNING! Verify that there is clearance before drilling holes for the LED's or switches.

4. **Install Front LED Turn Lights** – Mount the LEDs on the front right and left fenders. The front LED Turn Indicators can be mounted with the rubber grommet or without. If the grommet is **not** being used drill 5/8" holes. If the grommet is being used drill 3/4" holes. Remove and install the rubber grommet from the LED into the hole if being used. Insert LED into the hole with the Top marking up. NOTE: the TOP marking is on the front of the LED lens.

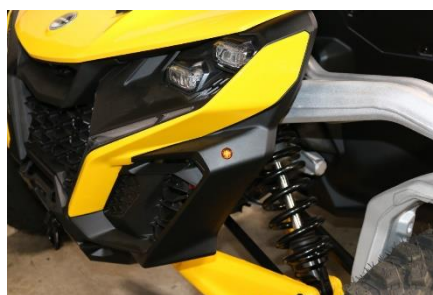

5. **Mount the Control Module** – Using the included screw, mount the Control Module in the Dash and plug the rear harness into it.



6. **Install Front Harness** - Un-roll the front harness, plug into the control module, run the cables with the yellow and green wires through the frame tube leading to the top of the radiator. Also remove the Headlight rear covers to run the wires.



Run the green and white wires to the right/passenger side LED, run the yellow and white wires to the left/driver's side LED. **NOTE: Black wire is positive and goes to Green and Yellow, white is ground, they will not work if reversed.** Secure the Harness using the provided cable ties.

7. **Install Activation Switches** - Attach the Switch Harness to the Control Module. Remove two switch blanks, remove the turn switch from the harness, run the connector through the opening, grease the terminals with the supplied grease and re-attach the switch. Do the same for the Horn/Hazard switch.



Note: Dielectric Grease - Just like the OEM uses on their switches, we recommend using Dielectric Grease on all switch terminals, this keeps the water out, thereby reducing corrosion and helps increase reliability! Open the grease and put on the switch terminals and the connector terminals on both the Turn and Horn switches, the more the better.

8. **Install Horn** – On the front fire wall in the center is a nut attached to the chassis, remove the nut, install the Horn Bracket, and reinstall the nut. From the Control Module, run the wire with the black and violet wire down the inside of the fire wall, above the accelerator pedal the frame goes through the fire wall and there is a small gap the that horn wire can be ran through, attach Violet and Black wire from front harness to the horn terminals, polarity does not matter.



9. **Attach Power Wire**, the system is plugged into the aux power port under the hood that is next to the remote + positive power post, un-plug the OEM accessory port cover (White Plug) by pushing the center button. Plug the 2-Way power Connector into the Control Module and run the power wire over to the AUX connector and plug into this port, it shares the same fuse as the accessory outlet on the dash (Cigar-Lighter). If the accessory port is already being used, we offer a Can-Am power port splitter. (Not Included) Part # CAN-AUX-SPLIT

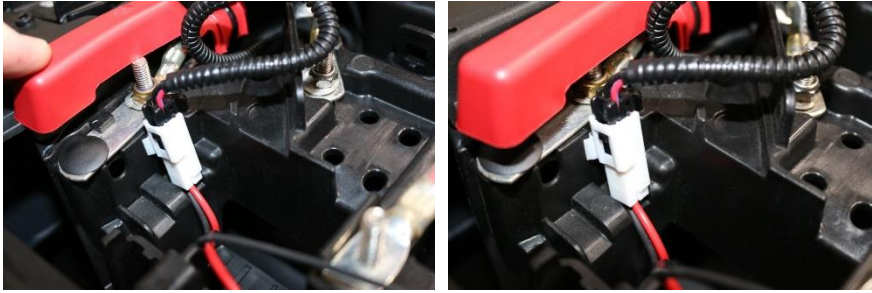

10. Re-install the removed parts. Verify operation of all lights. Cable tie any extra harness under dash.

Operation: The System uses momentary switches to activate. Press Right or Left Actuator accordingly. Will cancel as follows.

Press 1 Second for Lane Change, will stay on approx. 8 Seconds / 10 Flashes

Press 2 Seconds for Slowing to Turn Corners, will stay on approx. 20 Seconds / 30 Flashes

Press 5 Seconds for Traffic Lights when stopping and waiting, will stay on approx. 75 Seconds / 110 Flashes

The Systems Automatic Self-Cancelling may be overridden/Shut Off at any time by pushing the activated switch.

Hazard Lights - press to activate and press again to deactivate, it does not self-cancel.

Optional - The Tan wire next to the Turn Switch is for an optional Dash Indicator. When the TSS is activated it will flash 12 VDC that can be attached to an Optional Dash Mounted LED Light it is non-directional, flashes for both right and left signals. Also included is a Terminal that can be installed to make the Turn Indicator in the Can-AM X3 Display flash when activated. More Information can be found at www.xtcinstall.com

We can also be reached by email at support@xtcpowerproducts.com

XTC Power Products
A Division of XTC Motorsports LLC
380 E. Comstock Dr.
Chandler AZ 85225
480-558-8588
www.xtcpowerproducts.com

*Disclaimer: This kit is intended for off road use only and XTC Motorsports claims no responsibility for its use. It is up to the purchaser to make sure it complies with all Federal, State and Local laws.

R1

Copyright © 2023 XTC MOTORSPORTS LLC, all rights reserved.