



Ranger ⚡ ELECTRIC BIKES

USER MANUAL

26EB-MTN-500W

Please read through this manual carefully before use

 **IMPORTANT SAFEGUARDS AND TIPS**

WWW.VOLTOUR.COM

WELCOME TO THE VOLTOUR EBIKE FAMILY!

Thank you for purchasing a Voltour eBike.

We take pride in bringing a quality product that will offer years of enjoyment.

Please read this Owner's Manual carefully before setting up your bicycle and riding.

This manual should be considered a permanent part of your bicycle and remain with the bicycle when sold.

It is your responsibility to become thoroughly familiar with the proper operation, features, capabilities, and limitations of your Voltour eBike.

It is not possible or practical to warn you of all hazards associated with operating and maintaining your Voltour eBike, so you must use your own good judgment.

Please refer to this manual for proper care and maintenance instructions.

For replacement parts and accessories, reach out to Voltour for more assistance.



Contact Our Customer Support Team

1-855-233-9199

support@voltour.com

Live Chat at voltour.com

M-F 8:30am - 4:00pm MST



Register Your Voltour eBike

<https://voltour.com/apps/product-registration?form=product-registration>

◀◀ Simply scan this QR code!

Record your bicycle's serial number in the space below. The serial number is located on the head tube of the bike. Refer to page 44 for the location of the serial number.

Serial Number: _____

You must register your Voltour eBike within 30 days of purchase for the warranty to be valid.

Thanks for choosing Voltour!

TABLE OF CONTENTS

REGISTER YOUR E-BIKE	1
IMPORTANT	3
COMPLIANCE WITH THE LAW	5
SAFETY	6
BATTERY SAFETY	8
PACKING LIST	11
BIKE DIMENSIONS	13
ASSEMBLY	14
OPERATION	19
Handlebar Control Functions	19
Display Features	20
Display Control Functions	21
Display Functions	22
Switching Push-assistance Mode On/Off	23
How to Switch Speed Unit	24
How to Reset Trip Meter	25
Charging the Battery	27
Operating Your New E-bike	28
7 Speed Gear System	29
Pedal Assistance	30
Throttle Assistance	30
Your First Ride	31
Maximizing the Riding Range	31
SUSPENSION	32
CARE & MAINTENANCE	35
SPECIFICATIONS	38
GENERAL TROUBLESHOOTING	39
ERROR CODES & TROUBLESHOOTING	40
LIMITED WARRANTY	41
RETURN POLICY	45

IMPORTANT

1. **READ ALL SAFETY WARNINGS AND ALL INSTRUCTIONS.**
2. **Always ride within your limits and the limits of your Voltour eBike.**
3. **Bicycles are only for use by persons 18 years of age and above.**

This bike is not intended for use by persons with reduced physical, sensory, or mental capabilities or persons with lack of experience and knowledge that may make them susceptible to injury.
4. **WARNING:** It is the rider's responsibility to comply with all traffic related laws and to use proper equipment. This includes appropriate cycling attire and bike maintenance.
5. **Never ride under the influence of drugs and/or alcohol.**
6. **Consult a doctor before using the bike if you have any medical conditions or issue that affect your ability to safely perform physical activities or if you including:**
 - pregnancy;
 - heart, respiratory, back joint or other orthopedic conditions;
 - high blood pressure;
 - difficulty with physical exercise or restrictions from physical activity.
7. Protect against fire, electric shock, and injury to persons. Do not immerse cord, plugs, or eBike in water or other liquid.
8. Close supervision is necessary when the eBike is used by or near children.
9. Unplug the charger from the outlet when not in use and before cleaning.
10. Do not operate the eBike with a damaged cord or plug or after the eBike malfunctions, or has been damaged in any manner. **Contact Voltour for examination, repair, or adjustment.**
11. The use of accessory attachments not recommended by the eBike manufacturer may result in fire, electric shock or injury to persons.
12. Never modify your frame or bicycle in any way. Do not sand, drill, file, or remove parts from your bicycle. Do not install incompatible components or hardware.
13. Always attach the plug to the battery first, then plug the cord into the wall outlet.
14. Do not use the bike for anything other than its intended use.
15. Do not exceed the maximum total weight limit of **300 lbs. (136 kg)**. Please be sure to account for weight of accessories and cargo. For example, if you are pulling 30 lbs. (14 kg) of cargo then the maximum weight of the rider would be 270 lbs. (122 kg).

IMPORTANT

16. Always keep small parts away from children as they present a choking hazard.
17. **California Proposition 65 Warning:** This product can expose you to chemicals known to the State of California to cause cancer, birth defects or other reproductive harm.
**For more information: www.P65Warnings.ca.gov*
18. **SAVE THESE INSTRUCTIONS.**

PLEASE NOTE:

This manual is not intended as a detailed service, repair or maintenance manual. Please seek assistance from Voltour for service, repairs, or maintenance.

COMPLIANCE WITH THE LAW

READ THIS FIRST: SAFETY AND COMPLIANCE WITH THE LAW

Congratulations on the purchase of your new eBike. Your eBike is an excellent piece of personal transportation equipment that will give you good service for many years.

Before you start using your eBike, we want you to be aware of a few important points. Please read this section carefully.

- **Observe Laws Regarding the Use of Battery-Operated Bicycles**

Your eBike is designed and manufactured to meet safety requirements as a battery-operated bicycle. However, state and local laws governing the use of battery-operated bicycles on public roadways, parks, and other open areas may differ. Please check with your local authority before using your eBike in public areas.

- **Observe Laws Regarding the Use of Bicycles**

Note that all laws regarding the use of bicycles in public areas, such as those mandating the use of helmets and the use of infant seats, will automatically apply for eBikes. Check with your local authority on what restrictions might apply.

Bike Classification

States recognize that there are three classes of eBikes and require a label to be placed on the bicycle denoting the class of your Voltour eBike. The label includes the motor's wattage rating and top speed of your Voltour eBike.

Your Voltour eBike comes as a Class 2 bicycle and has a label with this information posted on the frame of the bicycle.



SAFETY

We Recommend the Following Safety-related Procedures:

- Wear a helmet.
- Ride in control at all times.
- Use lights and reflective gear in low light situations. Inspect your bike often — especially the brakes.
- Seek maintenance if there are any notable changes in bike performance.
- Know and observe the rules of the road before cycling. Bike users must follow all road rules.
- Ride defensively. To motorists, pedestrians, or even other cyclists, you are not as visible as you might think. Always watch for hazardous situations, and be ready to stop or take evasive action at all times. With the assistance of the electric motor, you may be travelling faster than drivers expect — beware of cars pulling out in front of you.
- Avoid road hazards. Watch for and avoid potholes, drain grates, railroad tracks, loose road material, and other hazards.
- Use both the front and the rear brakes together for best performance. Using ONLY the rear will significantly increase your stopping distance.

E-Bike Road Safety

- Always obey traffic laws including lights, signals, and road signs that apply to traditional cyclists, cars, and other vehicles. Stay in the appropriate lane, using bike lanes when available.
- Cyclists tend to break the speed limit and red light laws. Breaking the speed limit for bike lanes on an eBike poses a higher risk than traditional bicycles because eBikes are capable of traveling at a much higher speed. This will only put you at risk of an accident. Do not cycle on the sidewalk/pavements as it can put both you and pedestrians at risk.
- Be wary of everyone. Cars will not always realize how fast you are going and may assume that you are exponentially slower than them. To avoid the risk of accidents, always allow cars to get their right of way first, and do not rush. Be patient and alert, especially at intersections and turns.

SAFETY

- **Safety Instructions of Gear Operation:**

1. When using the derailleur lever, you can only pedal clockwise and shift gears from gears 1-7.
2. DO NOT use the derailleur lever when the eBike is still.
3. Begin to change the gear after the eBike speed reaches 5 mph.
4. Shift the gear to a low gear, such as 3-2-1 gear before stopping each ride, so that the bike can start easily next time.

- **Wet Weather and Night Riding Safety Instructions:**

1. Reduce the speed to ensure your own safety in wet weather. When turning, reduce the speed in advance within the controllable range, and the wet road will lead to a longer braking distance. It is necessary to slow down in advance, brake slowly, and DO NOT brake suddenly.
2. Turn on the light when riding at night, reduce the speed within the controllable range.

- **Precautions for Riding:**

When riding on the road, it is necessary to abide by the local traffic rules. Do not take the motorway. Do not overspeed. Do not run a red light. Use right side brake lever (rear brake) first or use right and left brake lever at the same time. Do not only use left side brake lever (front brake). When riding at night, it is necessary to turn on the headlights, keep the distance and drive at a low speed.

- **Riders:**



Your Voltour eBike is equipped for single rider only. The front and rear of this bike is NOT designed for additional riders.

BATTERY SAFETY

These safety precautions are provided for your benefit to protect you and those around you. Please read and follow them carefully to avoid unnecessary injury, damage to the product, or damage to other property.

• BATTERY

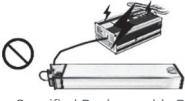

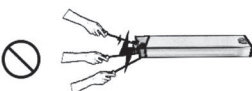
⚠ CAUTION

<p>■ Do not throw the battery into a fire. Do not overheat the battery.</p> 	<p>■ Do not connect the battery to other appliances other than your eBike.</p>  <p style="text-align: center;">Specified Rechargeable Battery</p>	<p>■ Use only the specified charger to charge the battery.</p> 
<p>■ Do not take apart or modify the battery.</p>  <p>Disassembly Prohibited</p>	<p>■ Do not connect positive and negative terminals by using metallic objects.</p> 	

(Overheating and/or rupture may result in this type of abuse.)

• BATTERY CHARGER

⚠ CAUTION

<p>■ Do not take apart or modify the charger.</p>  <p>Disassembly Prohibited</p>	<p>■ Do not subject the charger to shocks, e.g. by dropping. Keep the charger away from water.</p> 	<p>■ Do not touch the charger with your skin for long periods during charging. Buring of the skin may result, as external temperature of the charger during charging may become 104°F - 140°F (40°C - 60°C)</p>
<p>■ Do not cover the charger or place objects on it. Overheating, fire or electric shock may result.</p>	<p>■ Place the charger firmly on a flat dry surface. Using the charger upside down or stretching the cable tight may result in malfunction, fire or electric shock.</p>	<p>■ Do not short-circuit the terminals by using metallic objects. Overheating, fire or electric shock may result.</p>

BATTERY SAFETY

WARNING

- Keep the battery away from water. Pouring water on the battery may result in short-circuit, overheating or permanent damage of the battery.
- Do not submerge the battery. Soaking the battery in water may cause irreparable damage.
- Do not apply pressure to the cable or the plug.
NOTE: Placing the cable tightened between a wall and a window frame, or placing heavy objects on the cord or the plug may result in electric shock or fire.
- Be sure to insert the plug securely into a wall socket.
NOTE: Electric shock and overheating may result, causing fire.
- Do not touch the plug with wet hands.
NOTE: Electric shock may result.
- Keep out of reach of children or pets.
NOTE: Electric shock or injury may result.
- Do not attempt to use another maker or model's charger to charge the battery.
NOTE: Overheating, fire or electric shock may result.
- Do not use the charging plug and/or the power source plug when they are dirty, wet or dusty.
NOTE: Insulation failure due to moisture absorbed in the dust may result, causing fire.
Pull out the power source plug and clean it with a dry cloth.
- To remove the cable from socket, pull the plug, not the cable.
- Do not rotate the pedals when charging the battery while it is mounted on the bicycle.
NOTE: The cord may twist around the pedal or the crank, and the damage to the plug may result, causing electric shock or fire.
- Do not apply voltage over the rated value to the charger.
NOTE: Overheating, fire or electric shock may result.
- Do not use sockets, connectors and other wiring devices with a power source other than standard rated voltage (AC110-120 volts) power supply.
NOTE: Overheating, fire or electric shock may result.
- Do not use damaged components such as charge case, power cord, plug, etc.
NOTE: Electric shock, short-circuit or fire may result.

BATTERY SAFETY

Attention to Charging

- Your eBike battery is a lithium-ion battery. Lithium-ion battery requires specially designed chargers. You should never charge your battery with a substitute charger that is not designed for this use. Use of an unsuitable charger to charge a lithium-ion battery will result in overheating, fire or even explosion. If your charger is lost or damaged, contact Voltour to order a replacement.
- Charge your battery while the eBike is not in use. Turn off the bike before you charge it. You may charge your battery while it is mounted on the eBike, or after it has been removed from the eBike.
- Do not place either the charger or the battery near flammable substances while charging is taking place. Charging should not be done in the vicinity of infants and small children. It is also prudent to remove valuable objects from the immediate vicinity of the battery while it is being charged.
- The length of charging time depends on the level of charge the battery still holds. If a battery is completely discharged, it will take 5-6 hours to be fully recharged. When a battery is fully charged, the LED on the charger will transition from RED to GREEN. At this point, you should disconnect the charger. Do not continue to charge once full charge (green) has been achieved. Over charging may cause damage to the battery/charger.
- It is normal for the charger and the battery to be slightly hot while charging is on-going.

Disposal of Battery

Be sure to dispose of your battery properly. We recommend finding a certified battery recycling center or check out your local hardware store.

PACKING LIST

WHAT'S IN THE BOX



Voltour Ranger eBike (x1)



Charger (x1)



Battery (x1)



Keys (x2)

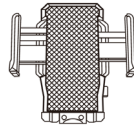

Phone Mount (x1)



Reflector (x2)

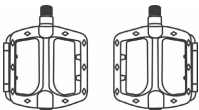

Pedal (x2)



Bell (x1)

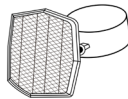

Seatpost Reflector (x1)



Owner's Manual (x1)



Tool Kit (x1)









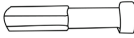

IMPORTANT: Check That The Package Is Complete And Undamaged

* It is recommended to retain the original packaging for a short period of time and keep it as intact as possible.

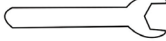
PACKING LIST

WHAT'S IN THE TOOL KIT

The eBike is 85% assembled. You only need to install the handlebars, front wheel, pedals and headlight. Please use the tools below to assemble the bike.

#	Tools	Parts
1		Front Wheel, Pedals
2		Derailleur, Bell, Phone Mount*
3		
4		Headlight
5		Front Fork Protector
6		Foldable Stem*, Seat
7		Handlebars
8		Throttle, Brake, Fender, Rack*
9		Motor
10		LCD Display, Switch
11		Hydraulic Brake*

* This is a general-purpose tool kit, some items may be optional accessories.

* Riding a bicycle is an inherently dangerous activity, and it is your responsibility to ride safely and within your abilities. Proper assembly is vital to the safe operation of your bicycle, so seek professional assistance if you are unable to complete the assembly of your bicycle as outlined in this manual.

BIKE DIMENSIONS

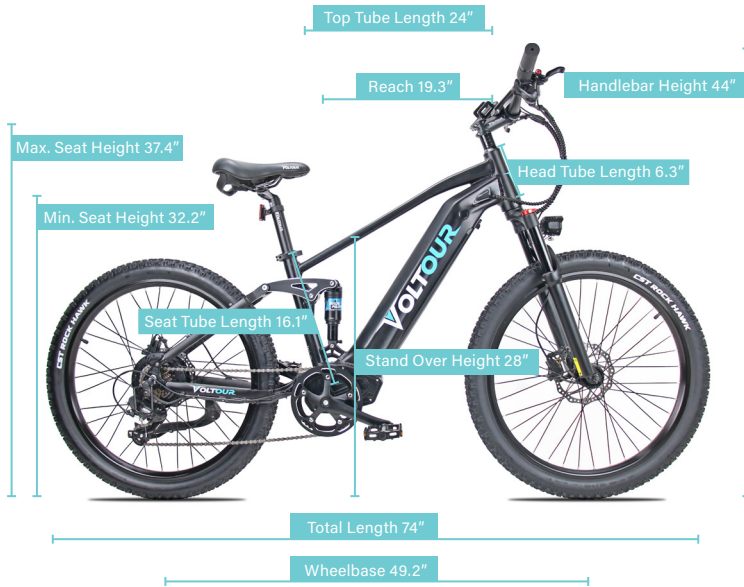

Handlebar Length



ASSEMBLY

IMPORTANT: The following steps are only a general guide to assist in the assembly of your eBike and are not a complete or comprehensive manual of all aspects of assembly, maintenance, and repair. Seek professional assistance if you are unable to complete the assembly of your eBike as outlined in this manual.

HOW TO INSTALL FRONT WHEEL



Step 1: Remove fork and brake protector.



Step 2: Fork and brake protector removed.



Step 3: Put on front wheel, tighten the nuts on both sides.

HOW TO INSTALL HEADLIGHT



Step 1: Remove the screw.



Step 2: Put headlight in proper position.



Step 3: Tighten the screw.

ASSEMBLY

HOW TO INSTALL HANDLEBARS



Step 1: Remove the four screws.



Step 2: Put handlebars in proper position.



Step 3: Tighten the screws.

HOW TO INSTALL BELL



Loosen the screw of the bell, place the bell in the proper position on the handlebars, and then tighten the screw.

ASSEMBLY

HOW TO INSTALL PEDAL

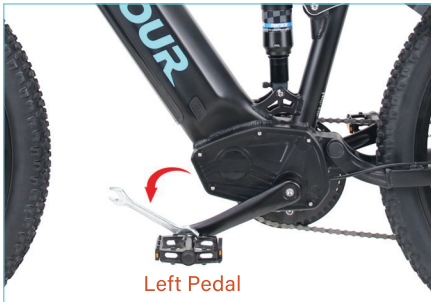

Tighten the left pedal counterclockwise.



Tighten the right pedal clockwise.

ASSEMBLY

HOW TO REMOVE BATTERY



Step 1: When the keyhole is in this position, the battery is locked.



Step 2: Insert key into keyhole and turn the key counterclockwise to unlock the battery.



Step 3: Hold the battery with one hand, use the other hand to turn the knob as shown above, and take out the battery.

Note: Always keep one key in a safe place. You cannot remove the battery from the bike if both keys are lost.

ASSEMBLY

SEAT HEIGHT ADJUSTMENT

To adjust your seat height, unlatch the seatpost clamp. Raise or lower seat to desired position (be careful to not raise past the minimum insertion point) and close the seatpost clamp. The open and closed positions of the seatpost clamp are shown below.

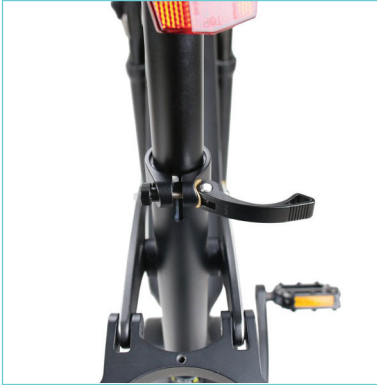

Open



Closed

IMPORTANT: Be sure that the seatpost is inserted beyond its minimum insertion marking as shown below. Failure to insert past the minimum insertion point will place undue stress on these components, increasing the risk of sudden failure potentially resulting in harm, injury, or death.



OPERATION

HANDLEBAR CONTROL FUNCTIONS

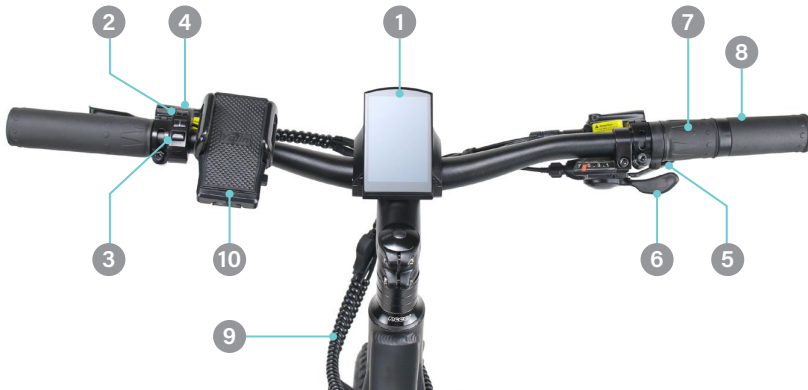

- | | |
|--------------------------|--------------------------------------|
| 1. LCD Display | 6. Gear Down |
| 2. Assistance Level Up | 7. Half-twist Throttle |
| 3. Assistance Level Down | 8. E-brake Lever |
| 4. Power On/Off | 9. Integrated Cable |
| 5. Gear Up | 10. Phone Mount with charging socket |

OPERATION

PHONE MOUNT FUNCTIONS



1. Charging Socket
2. Press this button to open holder clamp
3. Squeeze both sides to fasten the phone

OPERATION

DISPLAY CONTROL FUNCTIONS

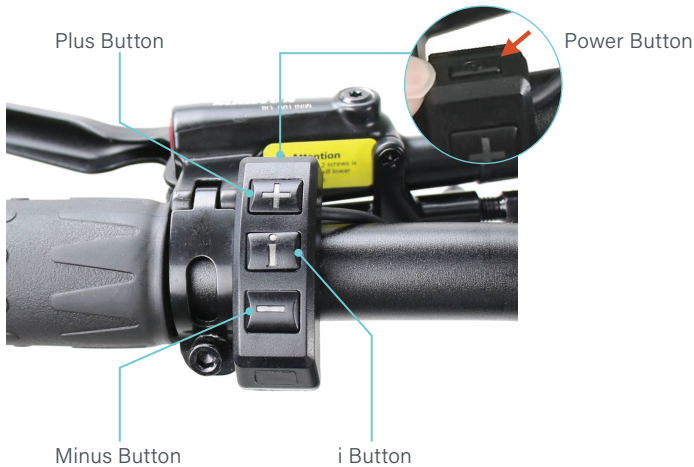

POWER BUTTON: This button will turn on the eBike. Hold the power button down until the display turns on.

[+] and [-] BUTTON: These buttons control the Pedal/Throttle Assist Levels. Press the [+] button to increase and [-] button to decrease.

HEADLIGHTS: The headlights that come with the bike are light-sensitive automatic headlights. It turns on automatically in the dark, but you can still turn it on or off manually. Hold the [+] button for 3 seconds until the light turns on. Repeat to manually turn off the light.

[i] BUTTON: Press the [i] button to toggle through the Odometer to see MAX speed, AVG speed, and Trip Time.

Notes:

1. The display will automatically shut down if the eBike has not been used for 10 consecutive minutes.
2. The pedal assist and throttle features will no longer work when the display is turned off.

OPERATION

DISPLAY FUNCTIONS



1. Battery Level Indicator
Note: When percentage is 0%, the battery needs to be charged immediately.
2. Speed Meter
3. Trip Meter
4. Throttle/Pedal Assist (PAS) Level Indicator
5. ODO/MAX Speed/AVG Speed/Trip Time
Note: After the display is turned on, it will show Speed (mph) and Trip Distance (mile) by default. Press the [i] button to switch between the ODO, MAX speed, AVG speed, and Trip Time.
6. Power Output
7. Headlight/USB Indicator

OPERATION

SWITCHING PUSH-ASSISTANCE MODE ON/OFF

To activate the push-assistance mode, hold the [-] button. After 2 sec, The eBike's drive is activated at a uniform speed similar to a slow walk while the screen displays the  icon as shown below. Hold down the [-] button for as long as you need the push-assistance. The push-assistance mode will turn off as soon as you release the [-] button on the operating unit. The eBike system stops the power output immediately.

Note: Push-assistance mode may be subject to local regulations. Check your local regulations to determine if allowed.



CAUTION: ALWAYS keep wheels in contact with the ground when using push-assistance mode.

OPERATION

HOW TO SWITCH SPEED UNIT

1. Access the settings menu by pressing and holding the [+] and [-] buttons on the control unit simultaneously until "SETTING" is displayed on the screen as shown in Figure 1.
2. Press the [i] button to enter display setting (Figure 2).
3. Press the [-] button to select "Toggle Unit" (Figure 3).
4. Press the [i] button to confirm and select "Metric" (Figure 4).
5. Press the [-] button to switch from "Metric" to "Imperial", and press the [i] button to confirm (Figure 5).
6. Press the [-] button to select "Back", and press the [i] button to exit setting.
7. Press the [-] button to select "EXIT", and press the [i] button to go back to main interface.

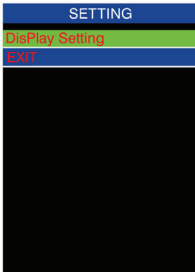

Figure 1

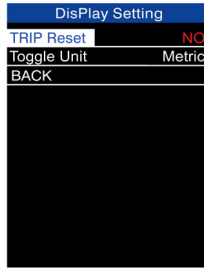

Figure 2

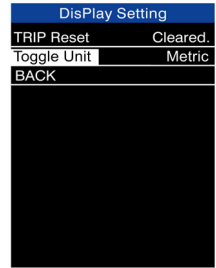

Figure 3

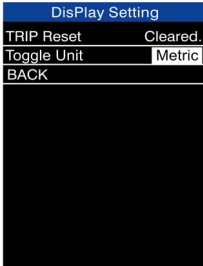

Figure 4

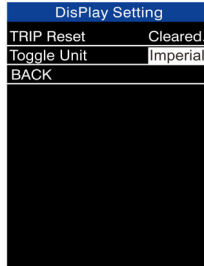

Figure 5

OPERATION

HOW TO RESET TRIP METER

1. Access the settings menu by pressing and holding the [+] and [-] buttons on the control unit simultaneously until "SETTING" is displayed on the screen as shown in Figure 1.
2. Press the [i] button to enter display setting (Figure 2).
3. Press the [i] button to select "TRIP Reset". Press the [i] button again to confirm.
4. Press the [-] button to change NO to YES (Figure 3). Press the [i] button to confirm, and the trip meter will be cleared.
5. Press the [-] button to select "Back", and press the [i] button to exit speed setting.
6. Press the [-] button to select "EXIT", and press the [i] button to go back to main interface.

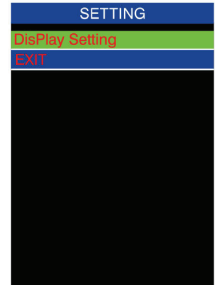

Figure 1



Figure 2

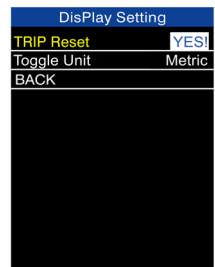

Figure 3

OPERATION

After above steps, your eBike is a complete functional bicycle without battery operation. Check all tightening points to make sure all fasteners are properly tightened. Take a short ride. Adjust the height of the handlebars and the height of the seat, if necessary, for maximum comfort.

IMPORTANT NOTICE:

Test the brake by lifting the front of the eBike and setting the wheel in motion (turn it) and apply the brake at the handlebars to stop it. If you could not set the wheel in free motion, or if you could not stop it by applying the brake, you need to re-adjust by increasing or decreasing the clearance.



CAUTION: Do not operate the eBike until you are satisfied that both the front and rear brakes are operational.

OPERATION

CHARGING THE BATTERY

1. Remove charger from box. Remove the rubber cap. Insert the plug at the end of the smaller cable into the charging terminal of the battery. The charging terminal is on the side of the frame as shown below.



2. Insert the power cord to any 120V wall outlet and start charging. **Note:** Always attach the plug to the battery first, then plug the cord into the wall outlet.
Charging time: 6 hours from 0%-100%
3. The indicator on the charger glows RED while charging and glows GREEN when charging is complete. The bike should be turned OFF while being charged. After charging complete, disconnect the charging cord and cover the charging terminal with the rubber cap. If a battery is installed on the eBike, the display panel will show the battery's state of charge when the bike is turned ON.



*Refer to page 10 for more information about battery charging in BATTERY SAFETY.
You are now ready to start using your eBike!

OPERATION

OPERATING YOUR NEW E-BIKE

The method to turn on the eBike is:

1. Press the power button on the switch until LCD Display on;



2. Twist the throttle on right handlebar or pedal the bike slowly, you can change the power level with [+] or [-]. Level 1 is the slowest and level 5 is the fastest, level 0 is pedal mode (no assistance).



Your eBike is driven by a motor embedded in the hub of the rear wheel. The motor is powered by a battery. The amount of power delivered to the motor and the accelerating force on the eBike is controlled by you in a way according to the power-assisted mode you choose.

You can configure the eBike to operate in the pedal-assist-only-mode or the full power mode (be sure to check against local laws to ensure full power mode is permitted) where you can also use the half-twist handlebar throttle to deliver power to the motor.

OPERATION

7 SPEED GEAR SYSTEM

The eBike comes with a 7 speed Shimano freewheel (Note: the freewheel is the cluster of sprockets on the rear wheel of the bike). This allows the rider to maintain a comfortable level of effort and pedaling speed throughout different terrains. For instance, while pedaling in lowest gear (the largest sprocket), it will be easier to pedal up hills. In the highest gear (the smallest sprocket), the rider will be able to reach higher speeds on flat or downhill terrain. 1st gear is the lowest gear of this drivetrain, while 7th gear is the highest gear. Use the shifters on the right handlebar to shift gears up or down. To shift down, press the lever near the gear indicator. To shift up, push the lever on the other side of handlebar.



CAUTION: Only change gears while the bike is in motion. Shifting gears at a standstill may damage the drivetrain. Do not change gears too quickly as doing so could cause the chain to fall off and the rider to lose control, which could result in serious injury. If the chain falls off, turn the bike off before fixing the chain. If you do not, and the motor turns on, you could sustain serious injury.

OPERATION

PEDAL ASSISTANCE

1. You must turn on the battery to use the eBike in pedal-assist mode.
2. In the pedal-assist mode, pedal assist is triggered when you pedal forward, and pedal assist stops when you stop pedaling. In other words, pedal assist works as long as you pedal. You don't need to pedal hard. All you need is to apply a light force to the pedals continuously to maintain the current flow.
3. When you apply one of the brakes, pedal assist will automatically stop, allowing the eBike to slow down and stop. Pedal assist will turn itself off when the eBike has reached the maximum speed of 20mph (32km/h).
4. You should use the gear shifter at the handlebars to set the gears appropriately according to road conditions and pedal, as usual, you will find that you need to exert a lot less effort and the eBike travels faster and at a more steady speed.

THROTTLE ASSISTANCE

1. In the handlebar throttle mode, the amount of throttle is determined by the throttle switch controlled by your right hand.
2. You control the throttle by twisting it from its resting position, the farther the throttle switch is from its resting position, the more power is delivered to the motor to accelerate the eBike. When you want to slow down, you simply release the throttle and let it return to its resting position, and simultaneously apply the brakes if necessary.
3. You do not need to pedal the eBike if you use the half-twist throttle. However, you can pedal while commanding throttle assistance. If you do pedal to help the movement, you conserve energy and the charge in the battery will last longer.

OPERATION

YOUR FIRST RIDE

Please be VERY CAREFUL when you are ready to get on your eBike for the first time because the eBike moves significantly faster than a regular bicycle at active pedal-assist mode. Take your eBike to an area with a lot of open space before you start. Do not start pedaling hard as soon as you get on the eBike (as you normally would do with a regular bicycle), as the eBike will accelerate under pedal-assist mode and you may be unprepared for the sudden increase in speed. However, after some practice, you will enjoy using the pedal-assisted function. Priority should be given to using the rear brake or both the front and rear brakes while riding, not just the front brake.

MAXIMIZING THE RIDING RANGE

- You should fully charge the battery before a long journey.
- Rough road conditions and hilly terrain will consume more energy.
- Frequent change of speed will consume more energy.
- Carrying more weight on the eBike will consume more energy.
- Keeping the tires properly inflated and keeping the eBike clean and well lubricated will save energy.
- Making sure that both wheels move freely when brakes are not applied will save energy. You should check brake adjustments frequently.
- Pedaling as you ride will consume less electrical energy and increase the riding range.
- When the battery is turned off, your eBike functions as a regular bicycle. If you embark on a very long journey, you might want to turn off the battery for long stretches where the road is level or downhill and pedal the eBike as a regular bicycle so that you can conserve electrical energy stored in the battery.

SUSPENSION

SUSPENSION FORK

The Voltour Ranger (500W) comes with an air-sprung suspension fork. This allows the rider to adjust the air pressure to soften the impact of rough terrain.



Rotate the red adjuster knob counter-clockwise to decrease compression damping and increase stroke speed. Rotate the red adjuster knob clockwise to increase compression damping until lockout.



To adjust air spring pressure, remove the blue air cap, attach a pump to the air inflation valve and inflate to the desired pressure.

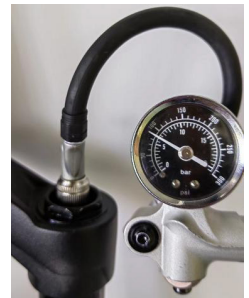

SUSPENSION

AIR SPRING PRESSURE

Refer to the recommended pressure chart below for adjusting the air pressure of the air-sprung suspension fork to your desired pressure level.

WHEEL (inch)	TRAVEL (mm)	RIDER WEIGHT / AIR PRESSURE							MAX PSI
		<120 lbs (<55 kg)	120-140 lbs (55-63 kg)	140-160 lbs (63-72 kg)	160-180 lbs (72-81 kg)	180-200 lbs (81-90 kg)	200-220 lbs (90-99 kg)	>220 lbs (>99 kg)	
		NOTE: E-bikes add 10 psi							
20	≤50	<70 psi	70-85 psi	85-95 psi	95-100 psi	105-120 psi	120-135 psi	135+ psi	200 psi
	80	70-90 psi	90-110 psi	90-105 psi	105-120 psi	120-135 psi	135-145 psi	145+ psi	
24	100	65-75 psi	75-85 psi	85-95 psi	95-105 psi	105-120 psi	120-135 psi	135+ psi	
	120								
27.5	140	60-70 psi	70-80 psi	80-90 psi	90-100 psi	100-120 psi	120-130 psi	130+ psi	
	160								

* Factory Setting: 100 psi

Regular Maintenance for the Suspension Fork

- Every Ride: Clean the dirt and debris from the upper tubes and wiper seals, check air pressure, and inspect upper tubes for scratches.
- Every 50 hours: Clean the lower legs with a dry cloth.

SUSPENSION

REAR SUSPENSION

The Voltour Ranger (500W) comes with an air rear shock. This allows the rider to adjust the air pressure to soften the impact of rough terrain.

Unscrew the valve lid to inflate. Hold the needle in the middle to deflate. After inflation or deflation, always make sure the lid is tightened to avoid air leaks.

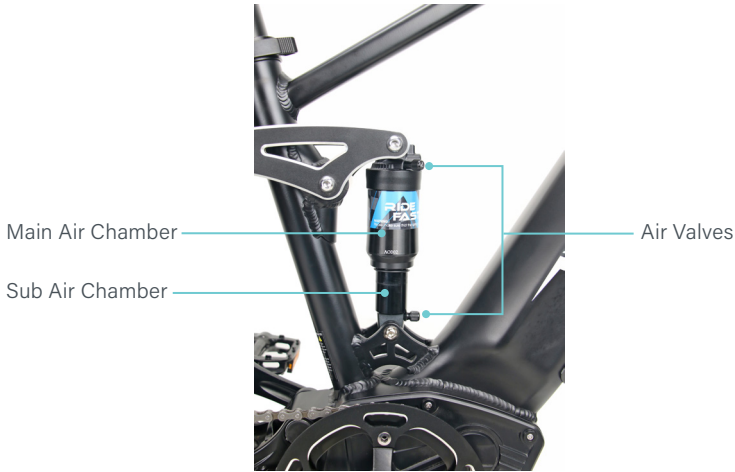

Refer to the recommended pressure chart below for adjusting the air pressure of the air rear shock to your desired pressure level.

NOTE: The recommended maximum air pressure is 180 psi. Exceeding the maximum psi may cause excessive air pressure and damage the cylinder.

Rider Weight (lbs)	Main Air Chamber (psi)	Sub Air Chamber (psi)
120	90	50
140	105	50
160	120	55
180	135	65
200	150	70
220	165	75

* Factory Setting: Main Air Chamber - 120 psi, Sub Air Chamber - 55 psi

CARE & MAINTENANCE

You should, in general, take care of your eBike the way you would with a regular bicycle by keeping it dry, clean and the moving parts well lubricated. You should also avoid parking your eBike in exposed areas whenever possible.

You should check the effectiveness of the brakes before each use.

For Your eBike, You Should Also Take Note of the Following:

- Your eBike is designed for regular country road use for a single person. Using your eBike for extreme maneuvers, such as extreme off-road use, jumping, or carrying excessive loads will damage the eBike and could cause serious injury.
- Do not use high-pressure water streams to clean your eBike, as water might seep inside the motor or the wiring compartment and cause rusting of electrical parts or short circuits.
- Avoid parking your eBike outside when there is rain or snow. At the end of a trip where there was rain or snow, bring the eBike inside and use a clean, dry towel to eliminate any wetness.

Special Care for the Battery and the Charger

- Use only the supplied charger to charge your battery. Do not use an unauthorized substitute. If your charger is lost or damaged, contact Voltour to order a replacement.
- Do not open or alter the battery or the battery charger.
- Do not place the battery near fire or corrosive substances. Do not immerse in water or other liquids.
- Avoid subjecting the battery to high temperatures, such as directly under the hot sun, for prolonged periods of time.
- Do not connect (short circuit) the two poles of the battery.
- After much use, your battery's charge holding capacity will decrease. If you find that your battery does not hold sufficient charge even for short trips, you should contact Voltour to order a replacement. Under normal use, the battery will undergo 1000 charging and discharging cycles.
- If the battery will not be used for an extended period of time, charge it fully and recharge it every 3 months. Store it in a cool place.

CARE & MAINTENANCE

- Your eBike battery is engineered with precision for high capacity and long useful life. We do not recommend that you use it to power other electrical devices. Improper use of the battery will damage the battery and shorten its useful life and may cause a fire or an explosion.

For the Battery, You Should Also Take Note of the Following:

- Keep the battery out of extreme temperatures. Operating temperature when charging: 32°-113°F. Operating temperature when discharging: -4°-113°F.
- Do not short circuit the discharge/charge terminals of the battery.
- Do not leave the battery charging overnight, or for long periods of time.
- To avoid damage to the battery, do not subject it to intense physical shock, severe vibration, or strong impacts.
- Do not expose the battery to water or other moisture. Protect the discharge/charge terminals from rain or water logging.
- Keep the battery away from children or pets.
- When the battery is not in use for an extended period of time, remove the battery and store it safely.
- Do not disassemble the battery.
- If you have any questions about this battery or its usage, contact the Voltour Customer Care Team.

Regular Maintenance for Your eBike

Every 1 to 2 months, it is recommended that you check the following:

- Check that the handlebars and seatpost are correctly inserted and tightened.
- Check that the wheel hub mounting nuts are correctly tightened.
- Check that the wheel rims are not cracked and that no spokes are loose or broken.
- Check that the tires are not worn or cut.
- Check that the tires are correctly inflated.
- Check that the battery contacts on the frame are not dirty or oxidized.
- Check that the battery is sufficiently charged.

CARE & MAINTENANCE

- Check that the front and rear brakes are working correctly.
- Check that the cables are sufficiently greased, and that the brake pads are in good condition.
- Check that the frame welds are in good condition, and are free of corrosion or oxidation.

Brake and Brake Cable Maintenance

It is inevitable that there will be sand, dust, oil stains and stains on the brake disc after riding , which will affect the braking effect. Wipe the disc brake disc with a dry rag and detergent regularly.

Derailleur Cable Maintenance

There will be dust and stains on the derailleur cable after riding , which will affect the transmission effect. Lubricating oil can be regularly injected into the contact and friction place between the transmission line and the appearance, so as to lubricate the transmission and achieve the best state.

Adjustment and Lubrication of Wheel Bearings

Wipe the dust and stains on the wheel bearing with a day rag regularly, and properly inject lubricating oil at the bearing to keep it rotating smoothly.

Tire Maintenance

Regularly inspect tire wear condition. Clean the mud, dust and stains on the tire to avoid tire corrosion affecting its service life. When the tire wears to the safety line position, replace it with a new one.

Handlebar and Saddle Maintenance

Regularly check whether the handlebars and saddle are secure. Regularly clean the dust and stains on the screws of handlebars and saddle with antirust agent.

SPECIFICATIONS

Our eBikes have a number of different traits, so it might not be possible to get every single attribute you want in the same model. Please find the specifications of Voltour eBikes as listed below.

Battery	48V 14.5Ah Lithium Battery
Motor	BAFANG 48V 500W Brushless Motor
Top Speed	Up to 20 mph (32km/h)
Mileage	28-33 miles (E-bike) 40-50 miles (PAS)
Charging Time	5-6 hours
Charger	US Standard 48V 2A smart charger
Battery Charger Input Volt	110/120 Volt AC
Battery Operational Temperature	32° to 104° Fahrenheit (0° to 40° Celsius)
Battery Life	Approximately 1000 complete charge/discharge cycles
Frame	26-inch aluminum alloy frame
LCD Display	Multi-function color display (with USB rechargeable)
Freewheel	7 Speed Cassette
Fork	26-inch alloy lockable air-sprung suspension fork
Brake	Hydraulic Double-disc Brake
Transmisson	7 Speed Cassette
Seat	Foam Seat
Tire	26*2.4 inch tires for mountain, snow, rain or muddy road
Recommended Tire PSI	40-65 PSI
Pedal Sensor	Speed Sensor
Phone Mount	Included
LED Headlight	Included
Max. Payload Weight Limit	300 lbs.
Recommended Rider Heights	5'7" - 6'5"
Bike Weight (without battery)	61.6 lbs. (51.8 lbs.)
Climb Grade	30 degree

GENERAL TROUBLESHOOTING

In the event of a problem, you should find out the true cause(s) and then choose appropriate solution(s) to rectify the problem. In case of doubt, please consult a qualified technician for service, repairs or maintenance.

Problems	Possible Causes	Solutions
Bike doesn't power on	<ol style="list-style-type: none"> 1. Insufficient battery power 2. Faulty connections 3. Battery not fully seated in tray 4. Brakes are applied 	<ol style="list-style-type: none"> 1. Charge the battery 2. Clean and repair connectors 3. Install battery correctly 4. Disengage brakes
Irregular acceleration and/or reduced top speed	<ol style="list-style-type: none"> 1. Insufficient battery power 2. Loose or damaged throttle 	<ol style="list-style-type: none"> 1. Charge or replace battery 2. Replace throttle
When powered on, the motor does not respond	<ol style="list-style-type: none"> 1. Loose wiring 2. Loose or damaged throttle 3. Loose or damaged motor plug wire 4. Damaged motor 	<ol style="list-style-type: none"> 1. Repair or reconnect 2. Tighten or replace 3. Secure or replace 4. Repair or replace
Reduced range	<ol style="list-style-type: none"> 1. Low tire pressure 2. Low or faulty battery 3. Driving with too many hills, headwind braking and/or excessive load 4. Battery discharged for long period of time without regular charging 5. Brakes rubbing 	<ol style="list-style-type: none"> 1. Adjust tire pressure 2. Check connections or charge battery 3. Assist with pedals or adjust route 4. Replace the battery 5. Adjust the brakes
The battery won't charge	<ol style="list-style-type: none"> 1. Charger not well connected 2. Charger damaged 3. Battery damaged 4. Wiring damaged 	<ol style="list-style-type: none"> 1. Adjust the connections 2. Repair or replace
Wheel or motor makes strange noises	<ol style="list-style-type: none"> 1. Damaged motor bearings 2. Damaged wheel spokes or rim 3. Damaged motor wiring 4. Disc not centered 	<ol style="list-style-type: none"> 1. Replace 2. Repair or replace 3. Repair or replace motor 4. Adjust the brake or replace
Sensor Issue	<ol style="list-style-type: none"> 1. Sensor loose 2. Sensor or cable damaged 	<ol style="list-style-type: none"> 1. Adjust the connections 2. Repair or replace
Pre-load and turn off bike suddenly	<ol style="list-style-type: none"> 1. Battery or motor over heat protection 2. Battery or controller cable loose 3. Battery or controller cable damaged 	<ol style="list-style-type: none"> 1. Wait 1-3 minutes to restart eBike 2. Adjust the connections 3. Repair or replace

ERROR CODES & TROUBLESHOOTING

In the event of a problem with the electrical components of your eBike, the display will show an error code.

Compare the code with this list below and HOW TO RESOLVE:

CODE	ERROR	HOW TO RESOLVE
21	Current Error	Check the cable that connects the rear hub motor to the rest of the system. Make sure it is free from grit or contaminants and is firmly connected.
22	Throttle Error	When you press and release the throttle, it should return to the original position. Remove any obstructions. Check the throttle and throttle cable for damage, such as a cut or frayed cable.
23	Motor Phase Error	Check the cable that connects the rear hub motor to the rest of the system and make sure it is free from grit or contaminants and is firmly connected. This error might appear if you don't reconnect the cable after removing the rear wheel (for example, after changing a flat tire, or transporting your bike in the trunk of a car). At least one of the motor phase wires has been damaged or is temporarily disconnected.
24	Motor Hall Sensor Error	The hall sensor inside the rear hub might be disconnected or damaged. Service or replace the rear hub.
25	Brake Error	When you apply the brakes - built in "magneticreed switches" disengage the motor's power when the lever is squeezed. If the lever is damaged (for example, following a crash), it might need to be replaced.
30	Communication Error	Poor connection between the controller and the display. Check all cable connections.

LIMITED WARRANTY

All Voltour eBikes and their individual covered components (as defined herein) are protected against all manufacturing defects in material or workmanship for one (1) year after the date of a qualify purchase (the "Warranty Period") to the **original registered purchaser**. This Limited Warranty is only applicable to purchases within the contiguous United States and Canada. This warranty does not apply to Alaska and Hawaii.

This warranty is non-transferrable and only applies to the original owner. This warranty gives you specific rights and purchasers may also have other rights, which may vary from state to state. Damage caused by failing to follow instructions in the manual, acts of God, accident, misuse, neglect, abuse, commercial use, alterations, modification, improper assembly, installation of parts or accessories not originally intended or compatible with the Voltour eBike as sold, operator error, water damage, extreme riding, stunt riding, or improper follow-up maintenance is not covered under this warranty. Warranty parts will only be shipped within the contiguous United States and Canada. We will not ship parts to Alaska and Hawaii.

Disclaimer of Consequential and incidental damages: The original registered purchaser of this bike, subsequent owners and all other intended and unintended users of this bike shall not be entitled to recover from Voltour eBikes any consequential or incidental damages. There is no warranty of merchantability or fitness for a particular purpose.

This limited warranty does not cover components of the bike that wear down with normal use of the bike including without limitation battery handle, tires, wheels, rims, tubes, brake pads, brake rotors, cables, and housing grips, chains, and spokes. The purchaser is responsible for maintaining these wear items.

Any damage or defects to covered components that result from failure to follow the owner's manual, unauthorized alterations, services and accessories will void the warranty.

The battery warranty does not include damage from power surges, use of 3rd party charger, improper maintenance or other such misuse, normal wear, or water damage (including rust.)

Stolen eBikes are not covered under warranty.

Accessories sold on voltour.com are not covered by warranty.

You must take necessary precautions to ensure that the bike and battery are not exposed to severe weather conditions. Exposure to very wet, hot, or cold conditions may void the warranty.

Determining whether damage or defect to an eBike or covered components is protected by this limited warranty shall be at the sole discretion of Voltour.

LIMITED WARRANTY

THE REMEDIES DESCRIBED ABOVE ARE YOUR SOLE AND EXCLUSIVE REMEDIES AND VOLTOUR'S ENTIRE LIABILITY FOR ANY BREACH OF THIS LIMITED WARRANTY. VOLTOUR'S LIABILITY SHALL UNDER NO CIRCUMSTANCES EXCEED THE ACTUAL AMOUNT PAID BY YOU FOR THE EBIKE, NOR SHALL VOLTOUR UNDER ANY CIRCUMSTANCES BE LIABLE FOR ANY CONSEQUENTIAL, INCIDENTAL, SPECIAL OR PUNITIVE DAMAGES OR LOSSES, WHETHER DIRECT OR INDIRECT.

SOME STATES DO NOT ALLOW THE EXCLUSION OR LIMITATION OF INCIDENTAL OR CONSEQUENTIAL DAMAGES, SO THE ABOVE LIMITATION OR EXCLUSION MAY NOT APPLY TO YOU.

THIS LIMITED WARRANTY GIVES YOU SPECIFIC LEGAL RIGHTS AND YOU MAY ALSO HAVE OTHER RIGHTS, WHICH VARY FROM STATE TO STATE.

TO THE EXTENT PERMISSIBLE UNDER APPLICABLE LAW, VOLTOUR DISCLAIMS ALL IMPLIED WARRANTIES, INCLUDING WITHOUT LIMITATION THE WARRANTIES OF MERCHANTABILITY AND FITNESS FOR A PARTICULAR PURPOSE FOR THE DURATION OF THIS EXPRESS LIMITED WARRANTY.

SOME STATES DO NOT ALLOW LIMITATIONS ON HOW LONG AN IMPLIED WARRANTY LASTS, SO THE ABOVE LIMITATION MAY NOT APPLY TO YOU.

Shipping Damages

Shipping damages are not covered by this limited Warranty, but Voltour will replace the damaged parts including bikes and accessories:

- Notify Voltour of a covered component damaged in the shipping process within 15 days of your eBike's arrival.
- Provide Voltour of a dated picture or video of the damaged covered components;
- Provide order information.

Replacement parts will not be sent until photographic, or video evidence has been provided to Voltour and deemed as shipping damage. Warranty parts will not be expedited and may take up to 14 days to arrive once the request has submitted by a Customer Care agent.

Shipping damages are very time sensitive and is it your responsibility to immediately inspect the eBike for damage upon receipt.

If you choose to set up your own shipping method to return your order, Voltour will not replace any parts damaged during such shipping method.

You will not be compensated for your time or efforts to replace the damaged parts.

LIMITED WARRANTY

Warranty Process

To start the warranty process to receive a replacement for a covered component under, you must:

- Contact Voltour Technical support team via website or email support@voltour.com. The support team will initially work with you on the problem with your eBike to identify potential simple fixes. To expedite your claim, be sure to include the following information:
 - Contact information
 - Serial Number
 - Detailed description of the problem
 - Picture or video clearly showing the problem
- If the support team determines that a covered component or part must be replaced, you will receive information detailing for returning the covered component and receiving the replacement.
- After receiving the replacement covered component, the support team will send you instructions on how to replace or install the new part to your eBike.
- You will be responsible for shipping costs with returning a covered component, unless Voltour agrees in writing to pay for such shipping costs. Replacement covered components under this limited warranty shall only be shipped to the address of the original registered purchaser.

Credit Card Chargeback

If any eBike purchase becomes subject to a credit card chargeback in any amount and you have possession of the eBike, this limited warranty will be void until the credit card chargeback has been resolved. This warranty will be invalidated if the chargeback case results in any amount of funds returned to the purchaser.

NOTE: Your insurance policies may not provide coverage for accidents involving Voltour eBikes. To determine if coverage is provided, you should contact your insurance company and agent. Voltour is not responsible for repair or replacement of damaged bikes or parts because of accidents. Damages caused by accidents are not covered under this policy.

Bike Performance Disclaimer

The eBikes listed range and top speed are estimates (not guarantees) of expected performance. Performance will vary based on conditions including, rider's weight, cargo weight, rider and cargo shape, terrain, tire pressure, brake adjustment, throttle vs. PAS

LIMITED WARRANTY

usage, pedal power, battery charge level, ambient temperature, and wind conditions. It is possible to get ranges and top speeds that differ from the listed estimates.

Liability Disclaimer

There are inherent risks and dangers that can not be predicted or avoided when riding any kind of bicycles. These dangers could result in a serious accident, injury, or death of the rider. It is the sole responsibility of the rider to become properly educated and prepared to ride safely. Voltour strongly encourages and recommends that all customers have a certified and reputable bicycle mechanic complete a full inspection of each component on the bicycle to ensure it is safe for operation. Voltour makes no claims or guarantees that brakes, battery, frame, motor, motor controller, display, electrical cables, electrical cable housings, fasteners, grips, fork, stem, shifters, headset seat post, seat post clamp, handlebar stem clamp, saddle, wheel hubs, handlebars, spokes, rimes, tires, tubes, derailleur, freewheel, cassette, throttle, kickstand, lights, reflectors, hardware, bottom bracket, or any other part or accessory, will be properly secured and adjusted upon arrival. Be sure to fully inspect your eBike and ensure that every part of your eBike is secured and adjusted properly.

Voltour is not responsible for any damage resulting from damaged, defective, or improperly secured parts. This includes, but is not limited to, damage to personal property, personal injury, or death.

Serial Number Location

Your Voltour Ranger eBike has its serial number printed on the head tube of the bike. Contact our customer support team if you're having trouble finding the serial number.



REGISTRATION REQUIRED FOR WARRANTY COVERAGE.
(See page 1 for registration information)

RETURN POLICY

Voltour stands by the quality of its products and want its consumers to shop with confidence. Before making a purchase, we want you to fully understand our returns and restocking fee policy applicable to all purchases including accessories, components and eBikes.

New & Unused

All purchases that are returned within **14 days of receipt for a full refund with no restocking fee** minus shipping costs. **All shipping related charges for returns are the responsibility of the recipient unless the error was made on Voltour's end.** The refund will be issued using the same payment method you used originally.

Used Bikes

All bikes in a used condition may be returned within 30 days of purchase. The bike must not have any damage and less than fifteen (15) miles on the odometer. The return **is subject to a forty percent (40%) restocking fee of the purchase price and return shipping charges.**

Returned of New & Unused Items Outside 14-day Window

If you are outside for 14-day return period and your item is in the **new and unused condition**, you may return the item. However, your return **is subject to a twenty percent (20%) restocking fee of the purchase price and return shipping charges.**

Return Shipping Costs

You are responsible for paying your own shipping costs for returning your item. Shipping costs are non-refundable. Voltour recommends using a trackable shipping service when purchasing shipping. We cannot guarantee that we will receive the item you are attempting to return. If you would like to use Voltour's shipping service, please contact customer support team for more information on purchasing the return shipping service via Voltour.

Refused Shipments - Fee

If you refuse delivery of an order that you asked us to ship to you, we reserve the right to charge a fee of 10% of the purchase price to partially cover shipping costs. We are unable to change, cancel, or intercept orders that have been shipped.

RETURN POLICY

Third Party Purchases

We do not accept returns of items purchased that are not made directly with Voltour. Please note that each of our third-party partners set its own return and exchange policies and procedures. You will need to contact the place of purchase to discuss their return policy.

Non-returnable/non-refundable Items

Apparel, batteries, used products*, special orders, sale items, gift cards and gifted items are not returnable for a refund.

**See Used Bikes Section to determine if your return qualifies.*

Exchanges

We do not offer exchanges. We will only replace or exchange items that are deemed defective or damaged by our customer support team. Please contact Voltour's customer support for assistance.

Returns/Exchange Process

All returns must be requested and approved by Voltour's customer support team. Any unauthorized returns will result in a delay of processing and will be subject to a restocking fee at the sole discretion of Voltour.

Be sure to provide the following information when requesting a return:

1. Name
2. Contact information
3. Order number or receipt
4. Reason for Return
5. Picture of Odometer (if used)

Failure to provide the information above will result in a refusal of return or a delay.

Once the return has been approved, you may return the item with the information requested by Voltour's customer support. Once the return has been received by Voltour, the return will be inspected and a refund will be issued within 5 days of receipt.

Voltour reserves the right to determine if a return is subject to a restocking fee based on inspection of the return.

Join the Voltour Community



Contact Us at:

1-855-233-9199 | support@voltour.com

VOLTOUR | 3000 E. CHAMBERS ST., PHOENIX, AZ 85040

Distributed by Voltour