

FONTANA

F O R N I



MANUAL

INSTALLATION AND USAGE MANUAL
BUILT - IN AND OUTDOOR OVENS

INDEX

- Pag. **7** INTRODUCTION AND CARE FOR MANUAL.
- Pag. **7** SYMBOLS USED IN MANUAL.
- Pag. **7** SCOPE OF MANUAL AND HEALTH & SAFETY DIRECTIVES.
- Pag. **10** WARRANTY TERMS AND WARNINGS RELATIVE TO OVEN AND USER.
- Pag. **11** INSTALLATION INSTRUCTIONS AND RULES.
- Pag. **13** INSTRUCTIONS FOR MAKING ELECTRICAL CONNECTIONS.
- Pag. **14** GENERAL DESCRIPTION OF PRODUCT.
- Pag. **16** DRAWINGS OF OVENS AND CARTS COVERED BY THIS MANUAL WITH DESCRIPTIVE TABLE.
- Pag. **25** INSTRUCTIONS FOR LIFTING AND SECURING OF OVEN ON CART.
- Pag. **31** OVEN CLEANING AND MAINTENANCE.
- Pag. **32** COOKING SUGGESTIONS.

INTRODUCTION

Dear Customer,

We would like to thank you for choosing our products. Our aim is to combine technology with simplicity of use, best performance and above all, safety. To ensure the highest performance of your product and fully benefit from all its features and available functions, we recommend you read this manual carefully before turning the oven on for the first time; if you have any doubts or experience any problems, we kindly invite you to contact your dealer or the company direct, which will ensure maximum collaboration and assistance.

CARE FOR MANUAL AND HOW TO READ IT

- Take care of this manual and store it in a place where it can be easily and quickly reached, for the entire service life of the oven.
- If this manual is lost or destroyed, or in any case is in poor condition, request a new copy from your dealer or from the company direct, specifying the identification data of the product.
- Important points or information that requires particular attention will be indicated in "bold text".

SYMBOLS USED IN THE MANUAL

In this manual, points containing critical information are highlighted by the following symbols:

NOTE

Indications concerning correct use of the oven and responsibilities of the persons in charge.

! **CAUTION:** Point expressing a note of particular importance.

! **DANGER:** An important behavioural note expressed to prevent injury and physical damage

SCOPE AND CONTENTS OF THIS MANUAL

The scope of the manual is to allow the user to adopt the necessary precautions and implement all necessary human and material needs for the correct, safe and long-term use of the product.

This manual contains all information necessary for the installation, use and maintenance of the product.

Strict observation of the instructions contained therein shall guarantee a high level of safety and performance of the product.

OVERVIEW

The product is to be used in compliance with the instructions contained in this manual and safety standards set by the specific local legislation where the product is installed.

MAIN HEALTH & SAFETY STANDARDS ADOPTED AND TO BE ADOPTED

- 1) Directive 2006/95/EC: "Electrical equipment designed for use within certain voltage limits".
- 2) Directive 2004/108/EC: "approximation of the laws of the Member States relating to electromagnetic compatibility".
- 3) Directive 89/391/EEC: "Introduction of measures to encourage improvements in the safety and health of workers at work".
- 4) Directive 89/106/EEC: "Approximation of laws, regulations and administrative provisions of the Member States relating to construction products".
- 5) Directive 85/374/EEC: "Approximation of the laws, regulations and administrative provisions of the Member States concerning liability for defective products".

WOOD-FIRED OVEN WARRANTY TERMS

The effective validity of the warranty must be proven by a tax document issued by the vendor.

- 1 2 years for the supporting structure, level of insulation, quality of the stainless steel (colour variations with gilding effect is not a defect but rather a normal reaction to the temperature), electrical system and paint.
2. 12 months for the motor, lamp holder, switches, glass panes of doors, thermometer, timer, transformer.
3. No warranty for the refractory surface.
Warranty exemption clauses:
 1. Failure to abide by the instructions.
 2. Negligent or careless use.
 3. Incorrect installation.
 4. Maintenance or repair works carried out by unauthorised personnel and/or use of non-original spare parts.
 5. Damage due to transport, damage due to circumstances and/or events caused by force majeure and which are nonetheless not attributable to manufacturing defects.

CHARACTERISTICS OF USER

The user of the product must be an adult and responsible person, having the necessary technical knowledge for the ordinary maintenance of the product's mechanical and electrical components.

Ensure children do not approach the product while it is being used, with the intention of playing with it.

SPARE PARTS

Only use original spare parts.

Do not wait for components to become worn due to use before replacing them. Replacing a worn component before it breaks will help to prevent injuries caused by accidents precisely due to the sudden breakage of components, which may cause serious damage to persons and property.

Perform periodic maintenance checks as indicated in the chapter "Maintenance and Cleaning".

TECHNICAL ASSISTANCE

Fontana Srl is able to resolve all technical problems regarding use and maintenance during the entire service life of the product.

The company's headquarters is always available to provide assistance, if possible via phone, or to direct you toward your closest authorised help centre.

SAFETY WARNINGS

WARNINGS FOR THE INSTALLER

- ⚠ • Check that the systems and set-up in the location where the product will be installed comply with local, national and European standards.
- Follow the instructions provided in this manual.
- Check that the characteristics of the flue and air intake comply with the type of installation.
- Do not make flying-lead connections with makeshift or uninsulated cables.
- Check that the electrical system is efficiently grounded.
- Always use personal protective equipment and other protective means set out by the law.

WARNINGS FOR THE USER

Set up the oven installation area in accordance with local, national and European regulations.

The oven, by its nature, is an appliance that becomes very hot and remains so for long periods of time, even after being turned off. Therefore, avoid touching hot parts and do not place objects, especially if they are flammable, near the walls.

Always use suitable protection when inserting or removing objects from the oven. Moreover, it is good practice to prevent children from approaching the oven when in use.

Never turn the oven on using flammable liquids, for example benzene, alcohol, kerosene or similar.

Always monitor the oven during cooking.

Keep your unprotected face or hands at a safe distance when opening the oven door, at temperatures higher than 200°C.

INSTRUCTIONS FOR INSTALLER

POSITIONING BUILT-IN OVENS

The wood-fired oven is no doubt a very evocative product associated with entertainment and the pleasure of cooking, spreading the sweet smell of bread and pizza all around. To achieve best results from your household wood-fired oven, it is necessary to prepare a brief design in regards to the location and spaces where the oven will be located before proceeding with its purchase. In addition to the oven itself, there are two other essential elements necessary for correct installation: the flue and insulation. The first is used to ensure the fumes generated by combustion exit the oven, and if the oven happens to be installed indoors, the flue outlet must be on the roof. Insulation on the other hand consists in the set of materials needed to insulate the oven from the external environment; this helps to avoid heat loss, which may be dangerous to persons and property, and which would otherwise reduce the efficiency of the oven heat, subsequently wasting the combustible material.

THE INSTRUCTIONS BELOW MUST BE STRICTLY FOLLOWED, OTHERWISE ALL LIABILITY SHALL BE DENIED BY THE COMPANY:

- Check that the size of the flue is compatible with the size required by the installation and the oven to be installed.
- The oven must have its own flue, which must not be used by other appliances.
- If the flue is not yet installed, it is recommended to install a circular type with smooth inner surface and properly insulated.
- Built-in ovens can be installed according to one of the following two options:
 - 1) positioned on the two masonry columns at a height of 60/80 cm off the ground, with a thickness of 12/15 cm.
 - 2) Positioned on a existing masonry surface. Make sure the oven is not in contact with cement-based renders.
- It is extremely important to maintain a clearance of 5 cm for suitable ventilation at the back and sides of the oven between the masonry and oven, and 10 cm at the top of the oven between the masonry and oven.
- It is essential to leave an opening on the cladding, at the height of the flue, of at least 30x40 cm for the maintenance and inspection of systems.

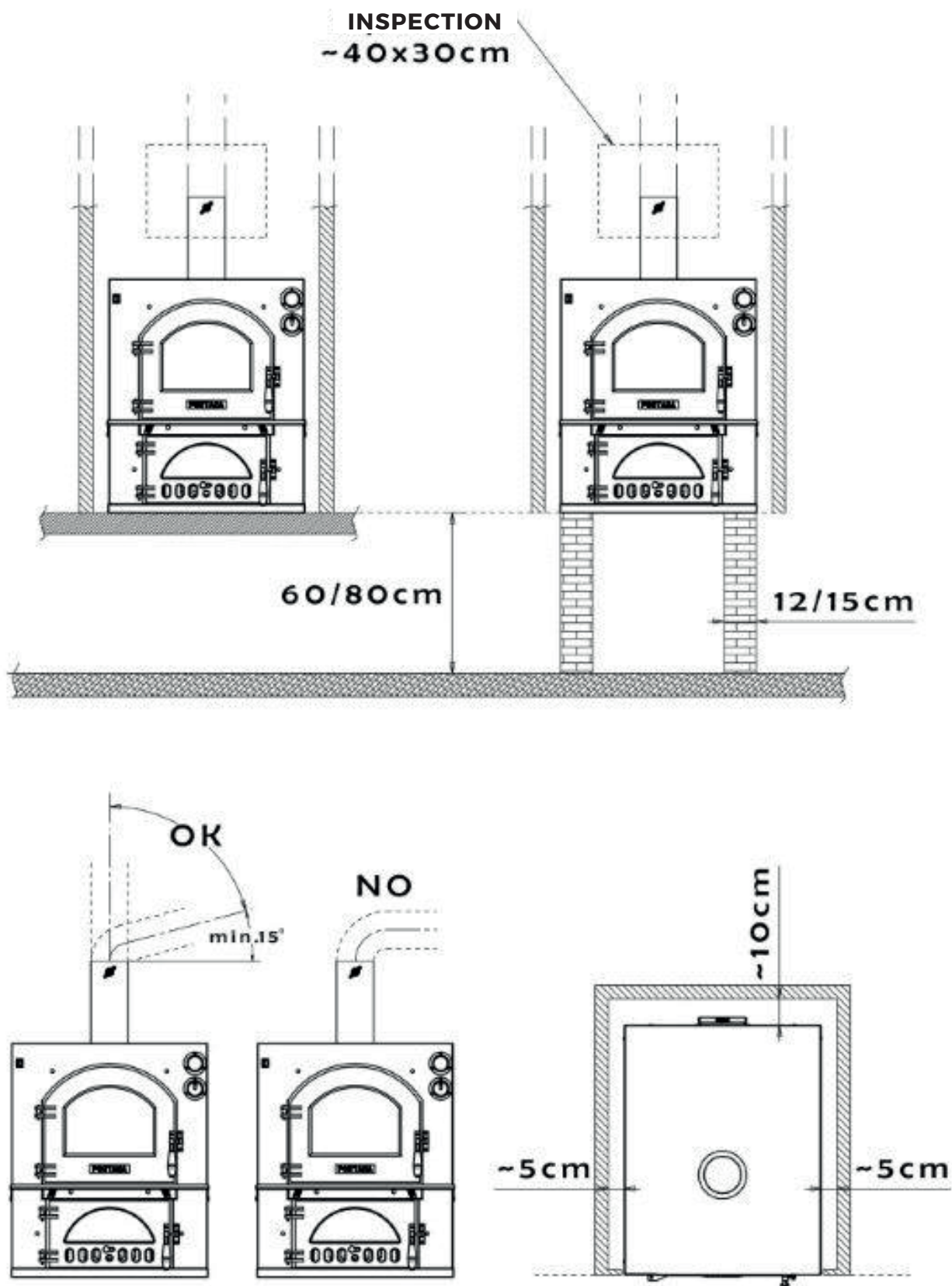

OBSERVATION: To facilitate the flue draft, it is a good idea to connect a flue with an inclination of at least 15°. As can be seen in the drawing, it is advisable to avoid connections with a 90° connecting curve

ELECTRICAL CONNECTION

INFORMATION REGARDING THE ELECTRICAL FIELD IS PROVIDED BELOW, WHICH MUST BE STRICTLY FOLLOWED. OTHERWISE ALL LIABILITY SHALL BE DENIED BY THE COMPANY.

- Check that the rated mains voltage is compatible with the oven's operating requirements.
- Before making the connection, check the efficiency of the grounding system. Grounding is mandatory by law.
- All changes that might be required in this field must be made by expert and authorised personnel.

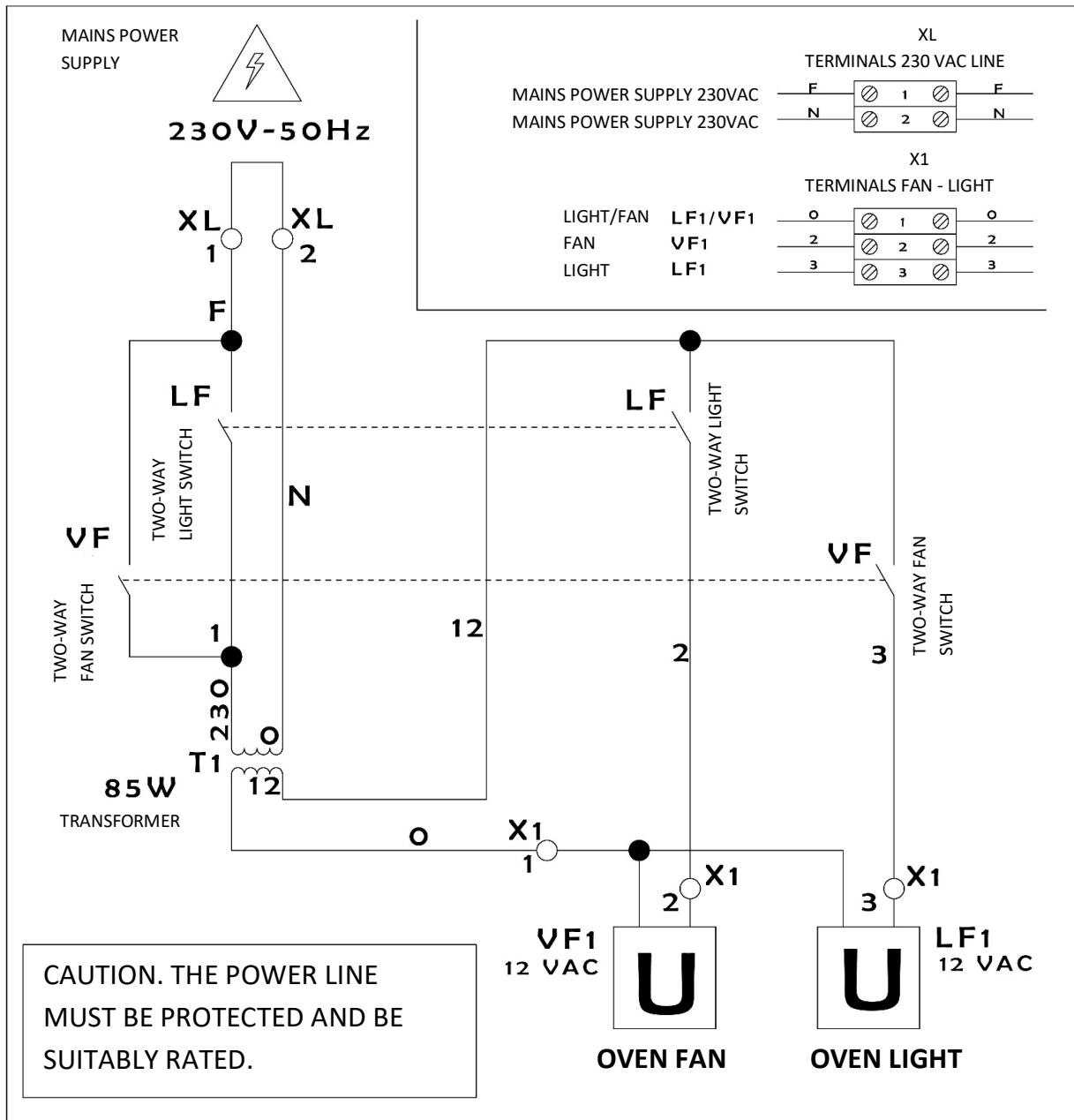

CHARACTERISTICS OF OVEN

GENERAL DESCRIPTION

The oven has been built with sheet steel treated for use at high temperatures. The cooking chamber, in special stainless steel, is separated from the combustion chamber by a triple layer consisting in:

- Steel surface
- Refractory bricks
- Refractory plate

This allows the even distribution of heat across the oven surface and prevents the formation of areas with different temperatures, otherwise detrimental to even cooking.

The central section of the oven, consisting in the combustion chamber and cooking chamber, is insulated by a layer of mineral wool, which allows the temperature inside the cooking chamber to remain constant, thus avoiding excessive heating of the oven's external panels, and also excessive external heat loss, which would otherwise lower the thermal output and subsequently increase the consumption of wood.

The materials used are high quality: the external structure is in powder-coated electro-galvanized metal or in stainless steel (depending on the model), the inside of the cooking chamber and flue are in stainless steel in all models. All models are equipped with electric lighting (**not the Italia basic external and built-in oven**), thermometer and a handy timer. In all ovens, the position of the flue has been carefully studied to optimise both the draft and path of the hot fumes, which evenly lap the cooking chamber (completely insulated from the combustion chamber), thus avoiding the formation of "preferential paths" that would otherwise cause excessive heating of certain parts of the cooking chamber, to the detriment of others.

This ensures maximum heat with minimum wood consumption.

To eliminate the moisture in the air and make the environment inside the cooking chamber as dry as possible, a special "drain" is installed to eliminate vapours.

This vapour "drain" must not be modified in any way, nor connected to any piping.

REGULATION OF COMBUSTION AIR AND SMOKE VALVE.

FOR SAFETY REASONS, A MINIMUM OVEN DRAFT MUST BE GUARANTEED.

WHEN THE COMBUSTION AIR REGULATOR IS CLOSED, AN AIR FLOW IS NONETHELESS GUARANTEED AND PASSES THROUGH THE BOTTOM PART OF THE DOOR.

THE SAME APPLIES TO THE SMOKE VALVE, WHICH IF POSITIONED IN CLOSED MODE, NONETHELESS GUARANTEES THE OUTFLOW OF FUMES TO AVOID THEIR STAGNATION AND THE SUBSEQUENT BUILD-UP OF CO₂.

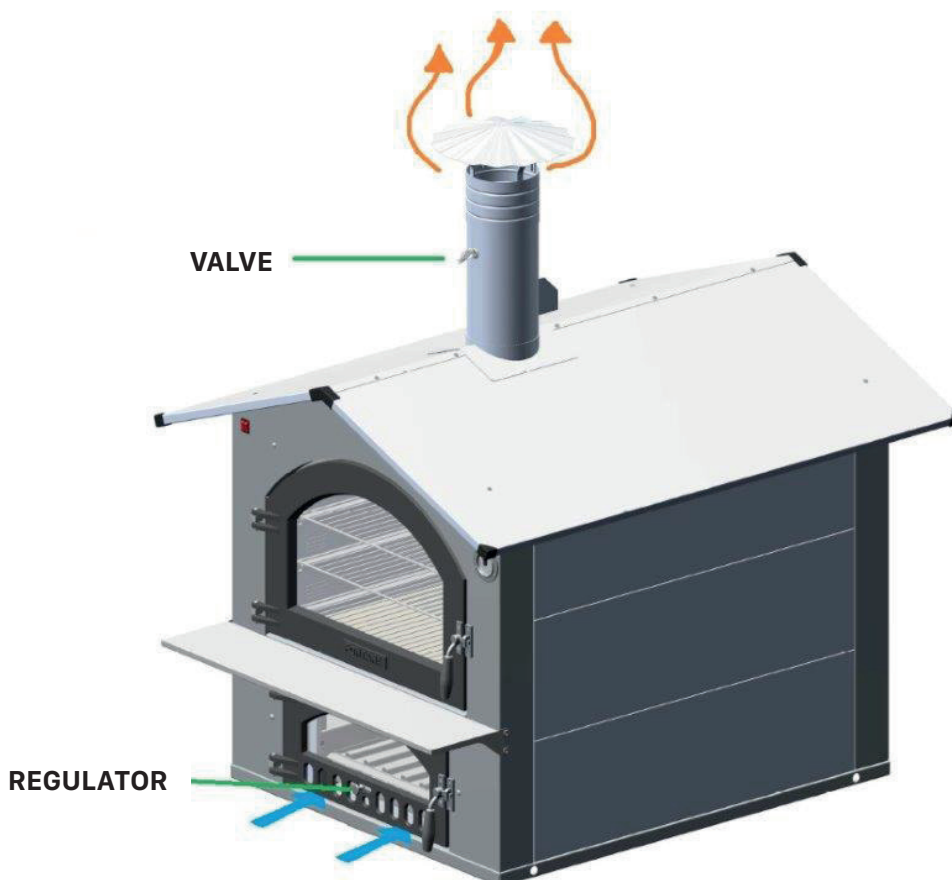

GOOD COMBUSTION ALSO DEPENDS ON THE FLUE TO WHICH THE OVEN IS CONNECTED.

IF THE FLUE DRAFT IS VERY HIGH, IT IS RECOMMENDED TO ADJUST THE SMOKE VALVE TO AVOID THE EXCESSIVE EVACUATION OF HOT FUMES, WHICH IF EXTRACTED TOO RAPIDLY, CREATES A RISK OF EXCESSIVE HEAT LOSS, THUS COMPROMISING THE INTERNAL STABILITY OF THE TEMPERATURE IN ADDITION TO THE EXCESSIVE CONSUMPTION OF WOOD. THE DRAFT IS ALSO AFFECTED BY ATMOSPHERIC FACTORS SUCH AS WIND, WHICH ARE MOST LIKELY TO INTERFERE WITH OUTDOOR, DIRECTLY EXPOSED MODELS. IT IS THEREFORE ADVISABLE TO PARTIALISE THE COMBUSTION AIR AND KEEP THE SMOKE VALVE PARTIALLY CLOSED FOR A MORE CONSTANT TEMPERATURE DURING USE.

THE CONDITIONS OF OVEN USE MUST BE EVALUATED CASE BY CASE.

External FORNO ITALIA series

INTERNAL DIMENSIONS			EXTERNAL DIMENSIONS			EXTERNAL MODEL	FUMES OUTLET (mm)	WEIGHT (KG)
A	B	C	P	L	H			
57	42	37	90	87,5	156	PREMIUM	140	175
57	42	37	90	87,5	156	BASIC	140	170

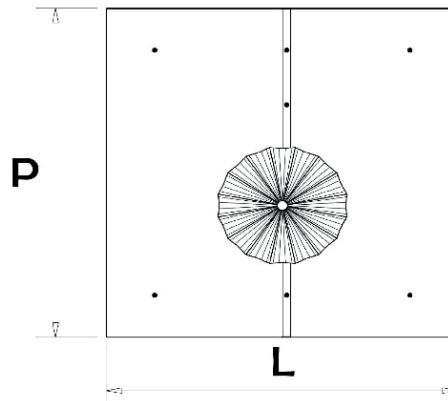
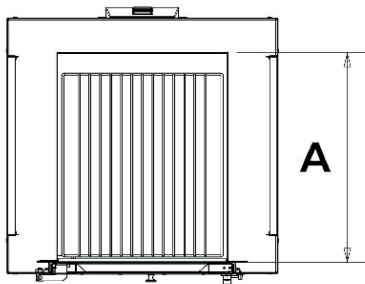
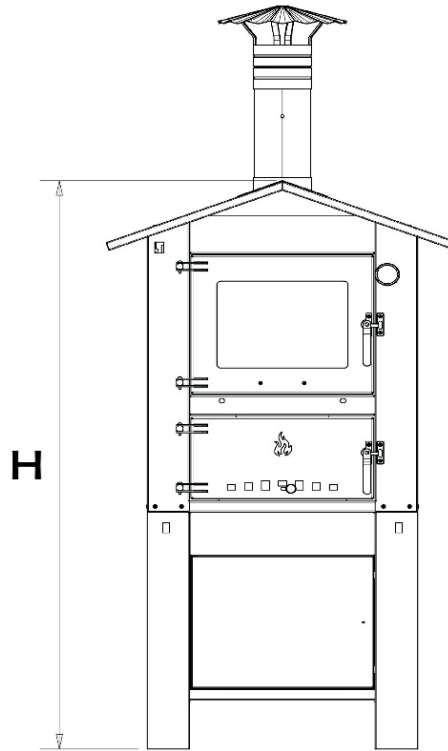
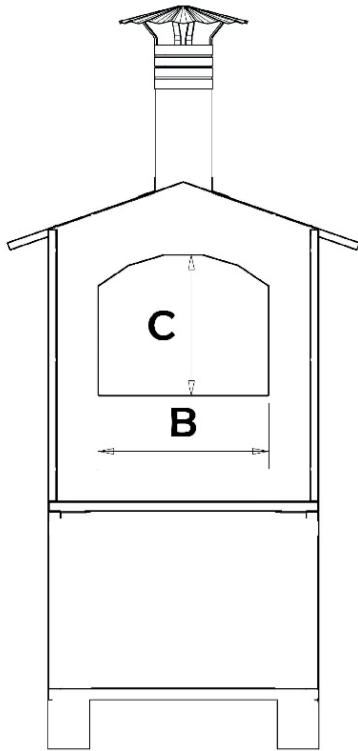

Built-in FORNO ITALIA series

INTERNAL DIMENSIONS			EXTERNAL DIMENSIONS			EXTERNAL MODEL	FUMES OUTLET (mm)	WEIGHT (KG)
A	B	C	P	L	H			
57	42	37	90	87,5	156	PREMIUM	140	175
57	42	37	90	87,5	156	BASIC	140	170

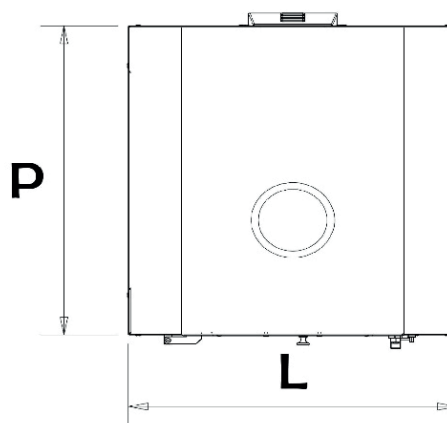
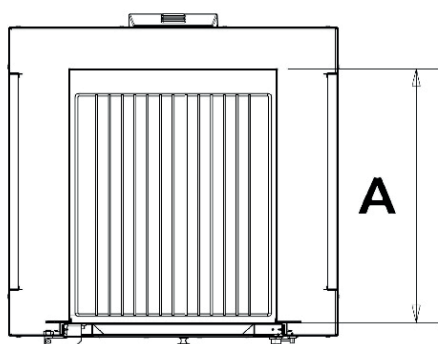
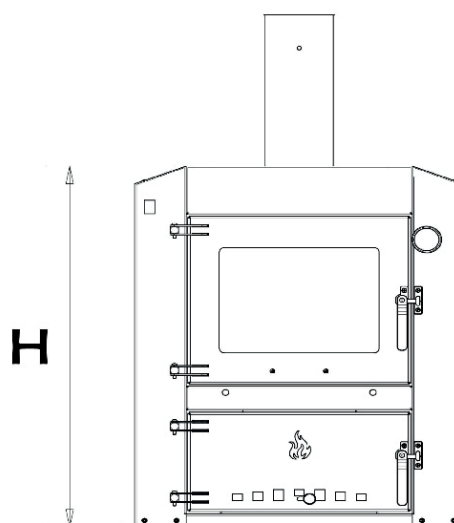
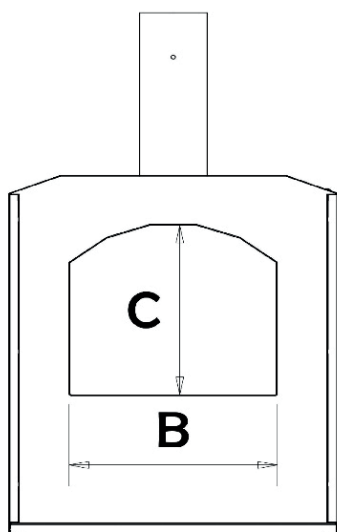

External FORNOLEGNA series

INTERNAL DIMENSIONS			EXTERNAL DIMENSIONS			EXTERNAL MODEL	FUMES OUTLET (mm)	WEIGHT (KG)
A	B	C	P	L	H			
80	45	41	120	95,5	163	80x45	140	260
80	54	45	120	105	171	80x54	140	300

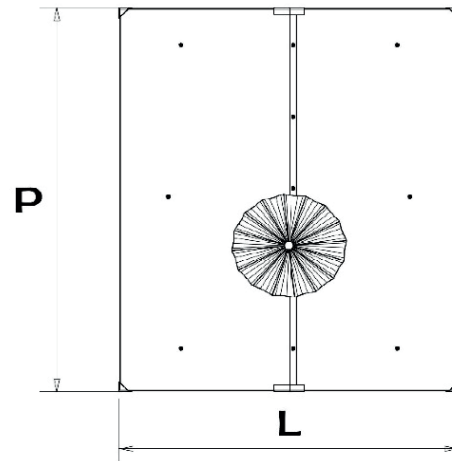
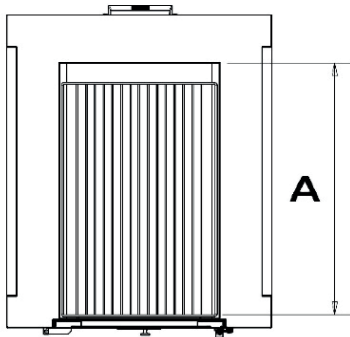
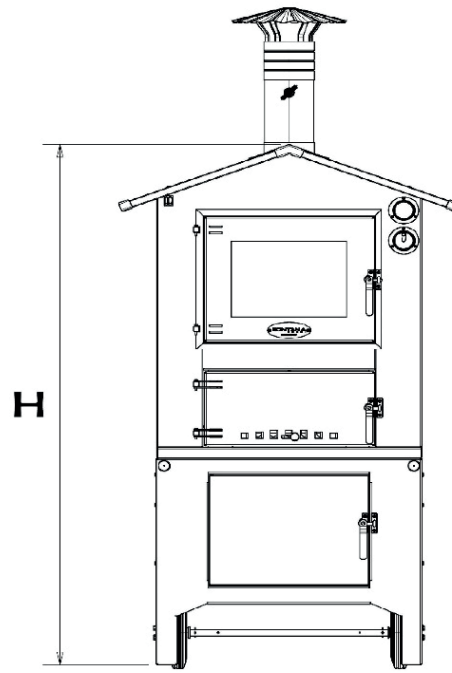
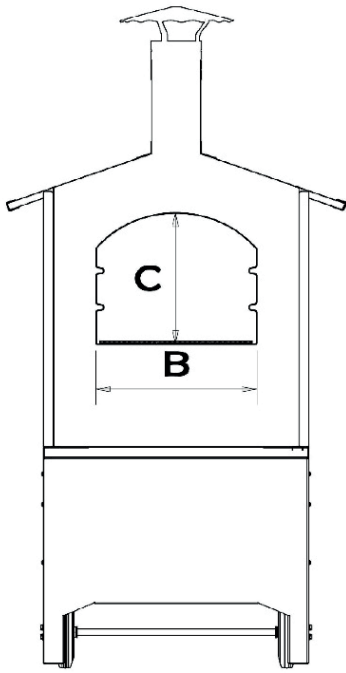

Built-in FORNOLEGNA series

INTERNAL DIMENSIONS			EXTERNAL DIMENSIONS			EXTERNAL MODEL	FUMES OUTLET (mm)	WEIGHT (KG)
A	B	C	P	L	H			
80	45	41	98,5	75	90	80x45	140	205

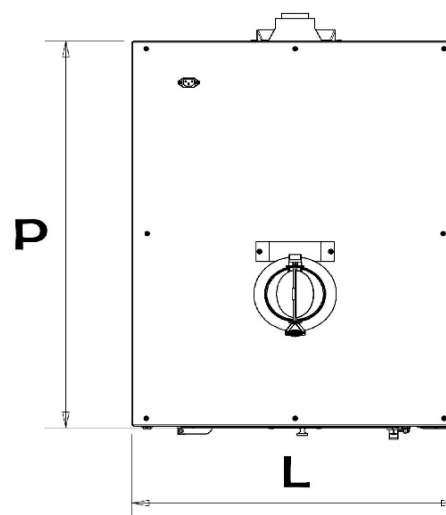
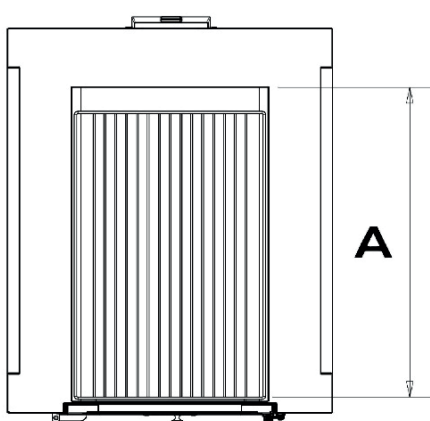
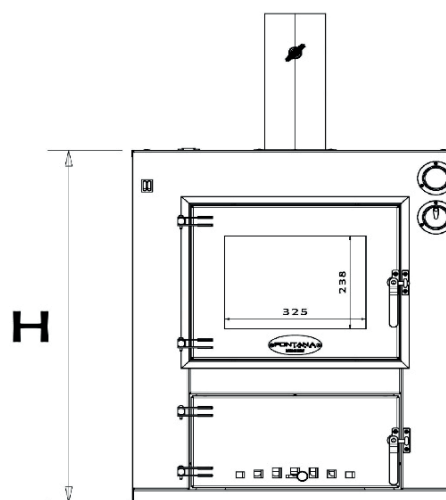
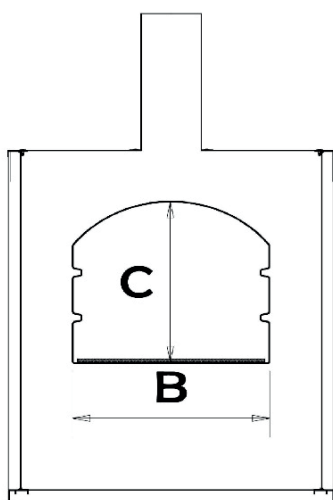

ENG

External PLATINO series

INTERNAL DIMENSIONS			EXTERNAL DIMENSIONS			MODELLO				FUMES OUTLET (mm)	WEIGHT (KG)
						GUSTO	GUSTO COMBI	ROSSO	ROSSO COMBI		
A	B	C	P	L (*L)	H						
57	45	42	95	102 (*138)	161	57x45	57x45(*)			140	250 (*295)
80	45	42	118	102 (*138)	161	80x45	80x45(*)	80x45	80x45(*)	140	310 (*358)
80	54	45	118	105 (*145)	168	80x54	80x54(*)	80x54	80x54(*)	140	360 (*408)
100	54	45	138	105 (*145)	168	100x54	100x54(*)			140	430 (*480)
80	65	45	118	115 (*156)	176	80x65	80x65(*)			160	420 (*468)
100	65	45	138	115 (*156)	176	100x65	100x65(*)			160	490 (*540)

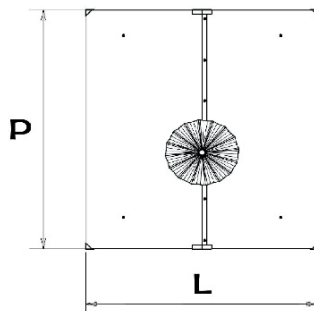
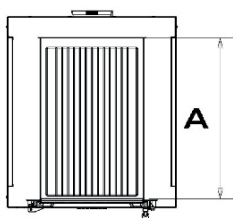
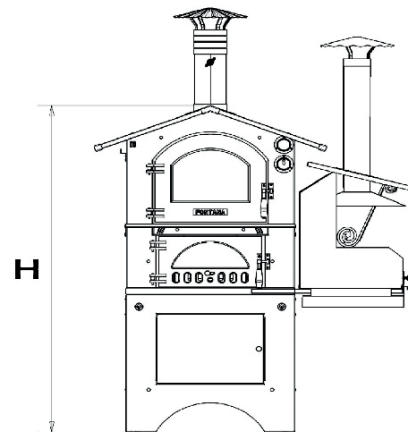
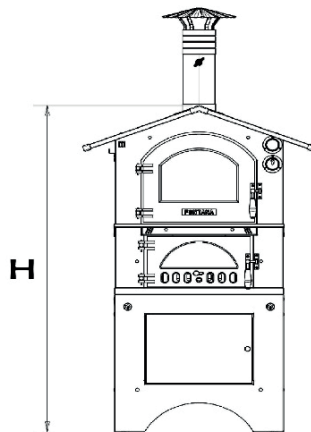
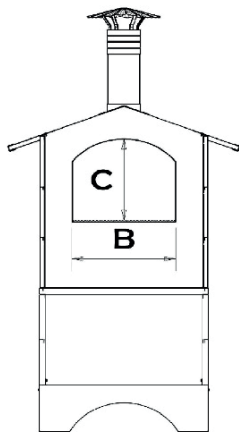

GUSTO / ROSSO

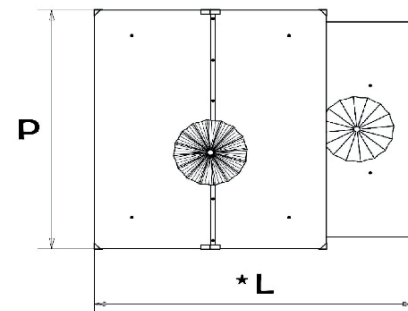

GUSTO / ROSSO COMBI

Built-in PLATINO series

INTERNAL DIMENSIONS			EXTERNAL DIMENSIONS			MODELLO		FUMES OUTLET (mm)	WEIGHT (KG)
						INC QV	INC V		
A	B	C	P	L	H				
57	45	42	71	74	88,5	57x45	57x45 (*)	140	190(*188)
80	45	42	94	74	88,5	80x45	80x45 (*)	140	240(*237)
80	54	45	94	83,5	94,5	80x54	80x54 (*)	140	280(*275)
100	54	45	114	83,5	94,5	100x54	100x54 (*)	140	345(*340)
80	65	45	94	93	100	80x65		160	330
100	65	45	114	93	100	100x65		160	390

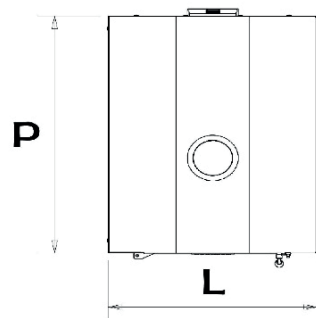
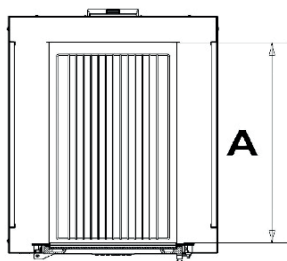
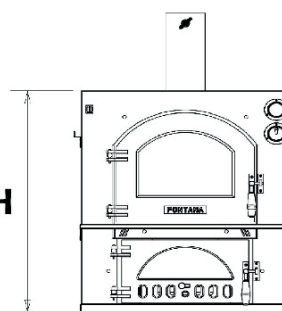
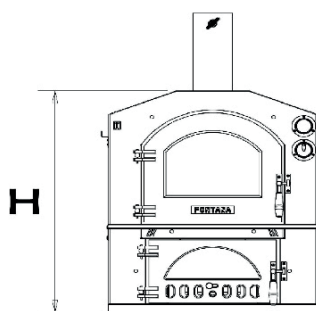
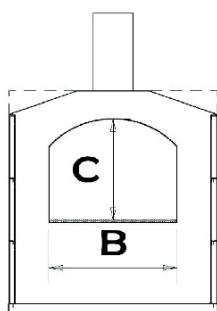

INC V

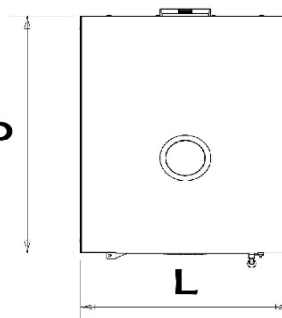

INC QV

ORO series

INTERNAL DIMENSIONS			EXTERNAL DIMENSIONS			MODEL	FUMES OUTLET (mm)	WEIGHT (KG)
A	B	C	P	L	H			
80	45	42	112	88	164	DIVINO	140	300
80	45	42	112	88	164	FIAMMA	140	300

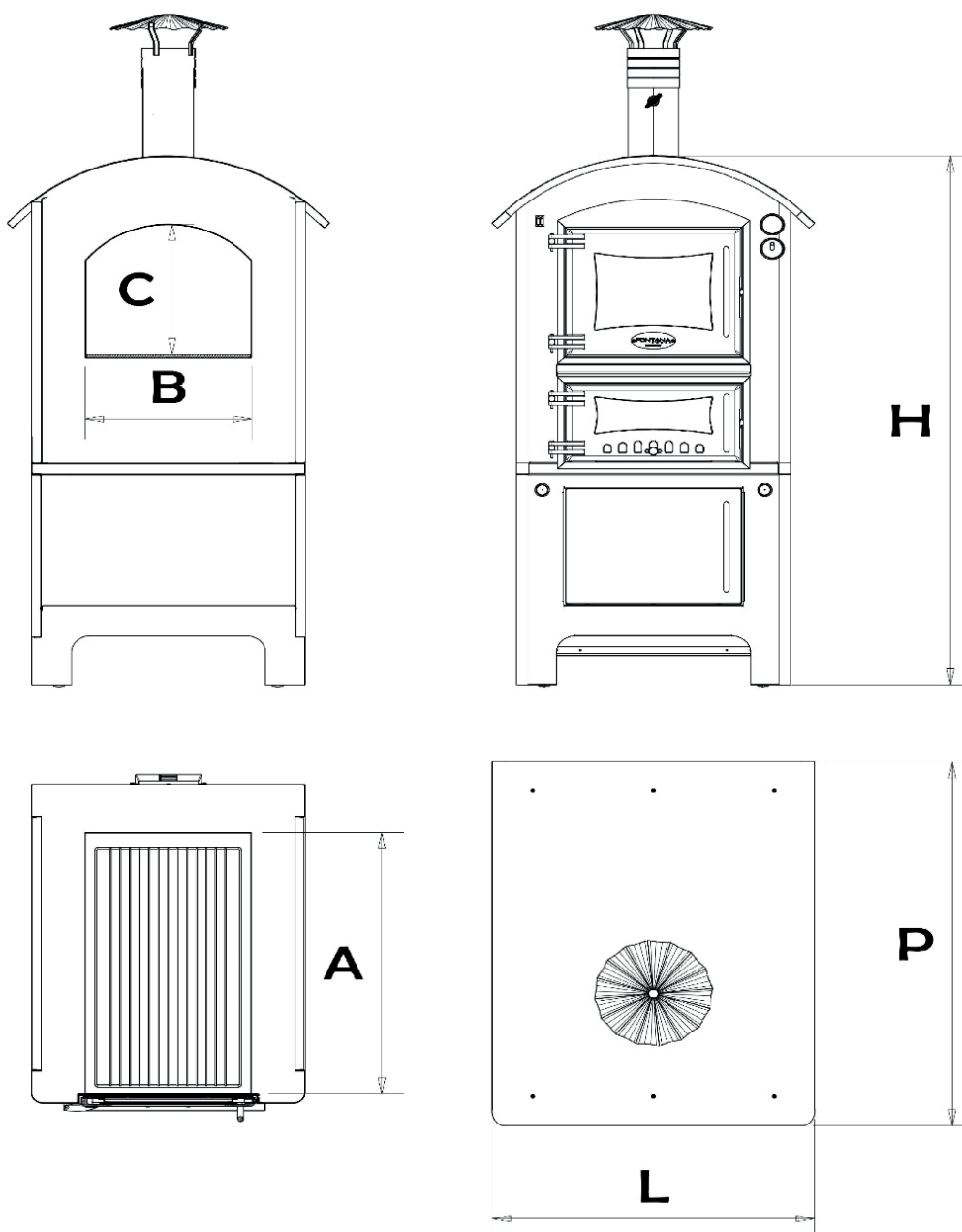

CARTS

CARTS PLATINO SERIES

EXTERNAL DIMENSIONS			MODELLO		WEIGHT (KG)
			GUSTO	ROSSO	
P	L	H			
71	74	68	57x45		42
94	74	68	80x45	80x45	50,5
94	83,5	68	80x54	80x54	62,5
114	83,5	68	100x54		66
94	93,5	68	80x65		62,5
114	93,5	68	100x65		70

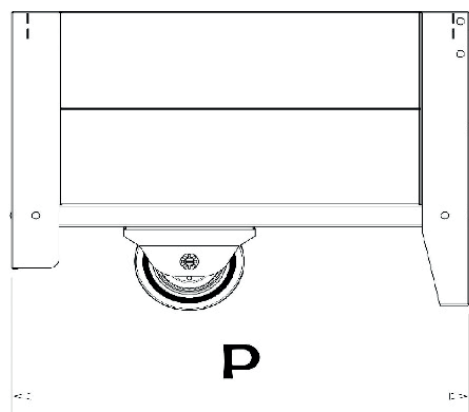
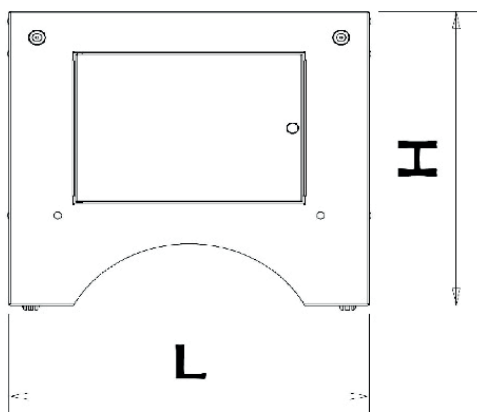

CARTS ORO SERIES

EXTERNAL DIMENSIONS			MODEL	WEIGHT (KG)
98	75	65	DIVINO	45
98	75	65	FIAMMA	45

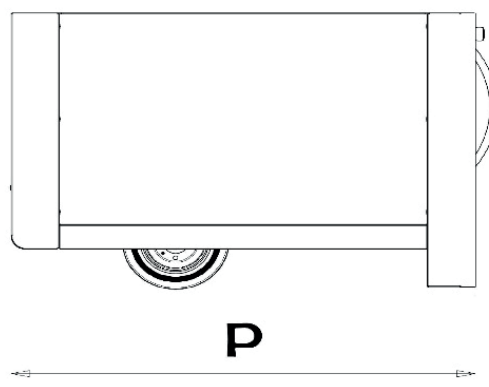
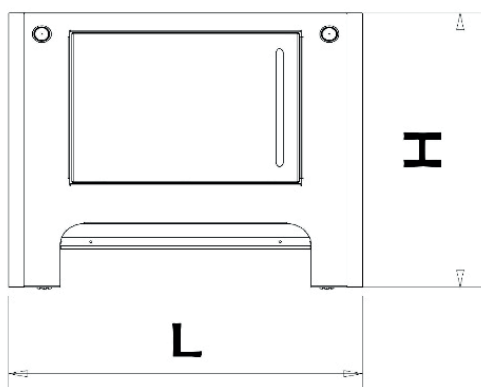

CARRELLI

CARTS FORNO ITALIA SERIES

EXTERNAL DIMENSIONS			MODEL	WEIGHT (KG)
P	L	H		
70	67	65	PREMIUM BASIC	35

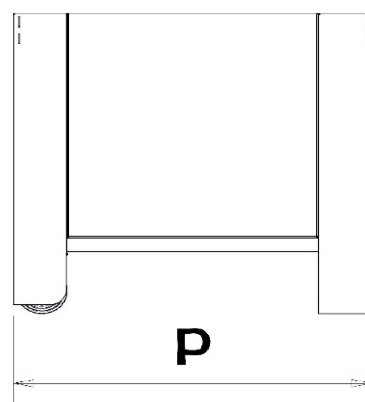
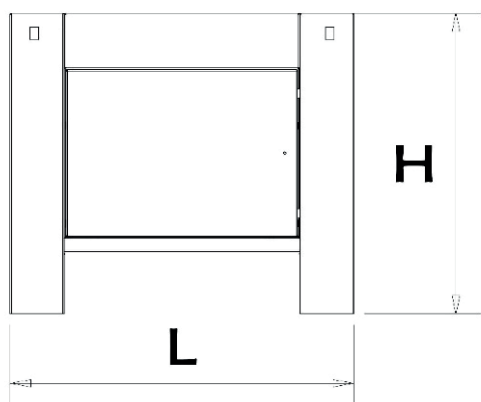

CARTS FORNOLEGNA SERIES

EXTERNAL DIMENSIONS			MODEL	WEIGHT (KG)
P	L	H		
98,5	75	65	80x45	48
98,5	84	65	80x54	52

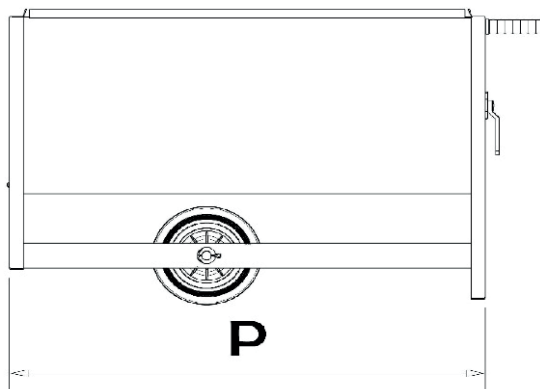
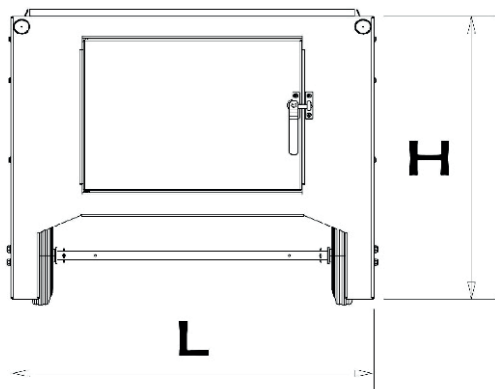

ENG

LIFTING AND SECURING THE OVEN ON THE CART



LIFTING OPTION no.1

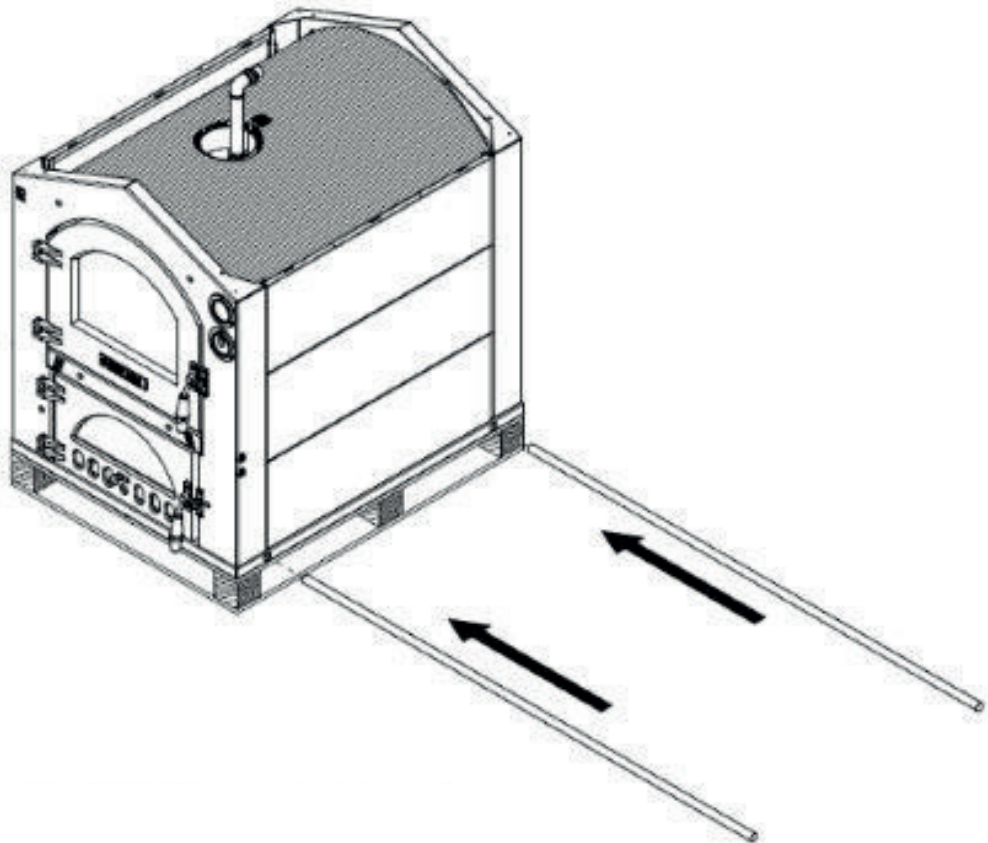
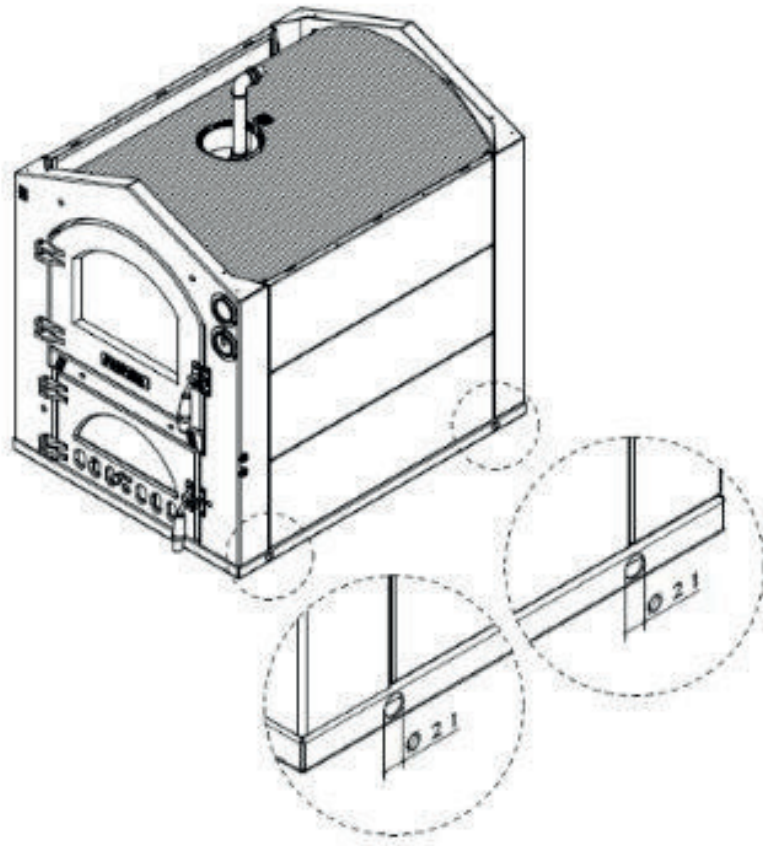

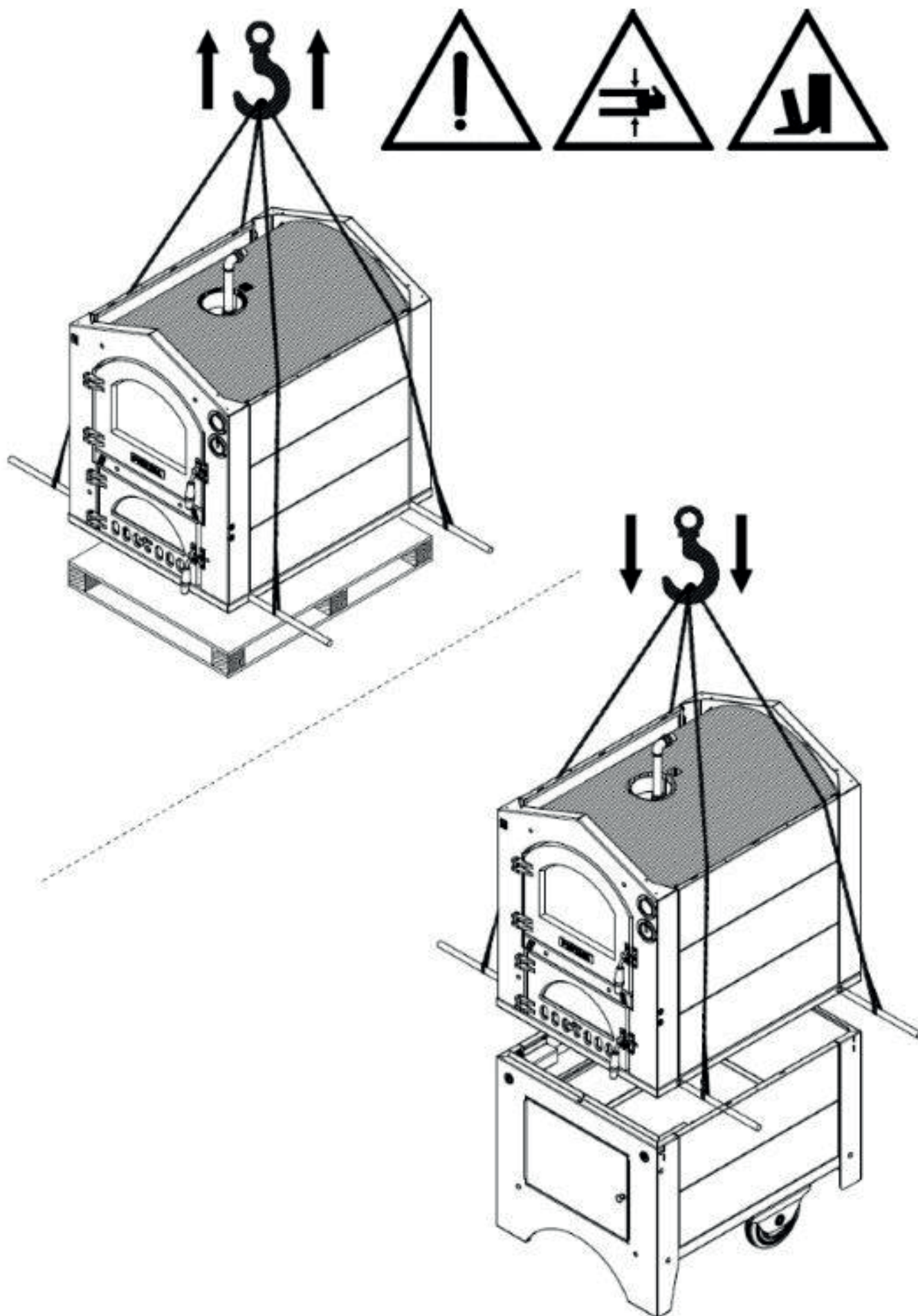

LIFTING OPTION no.2

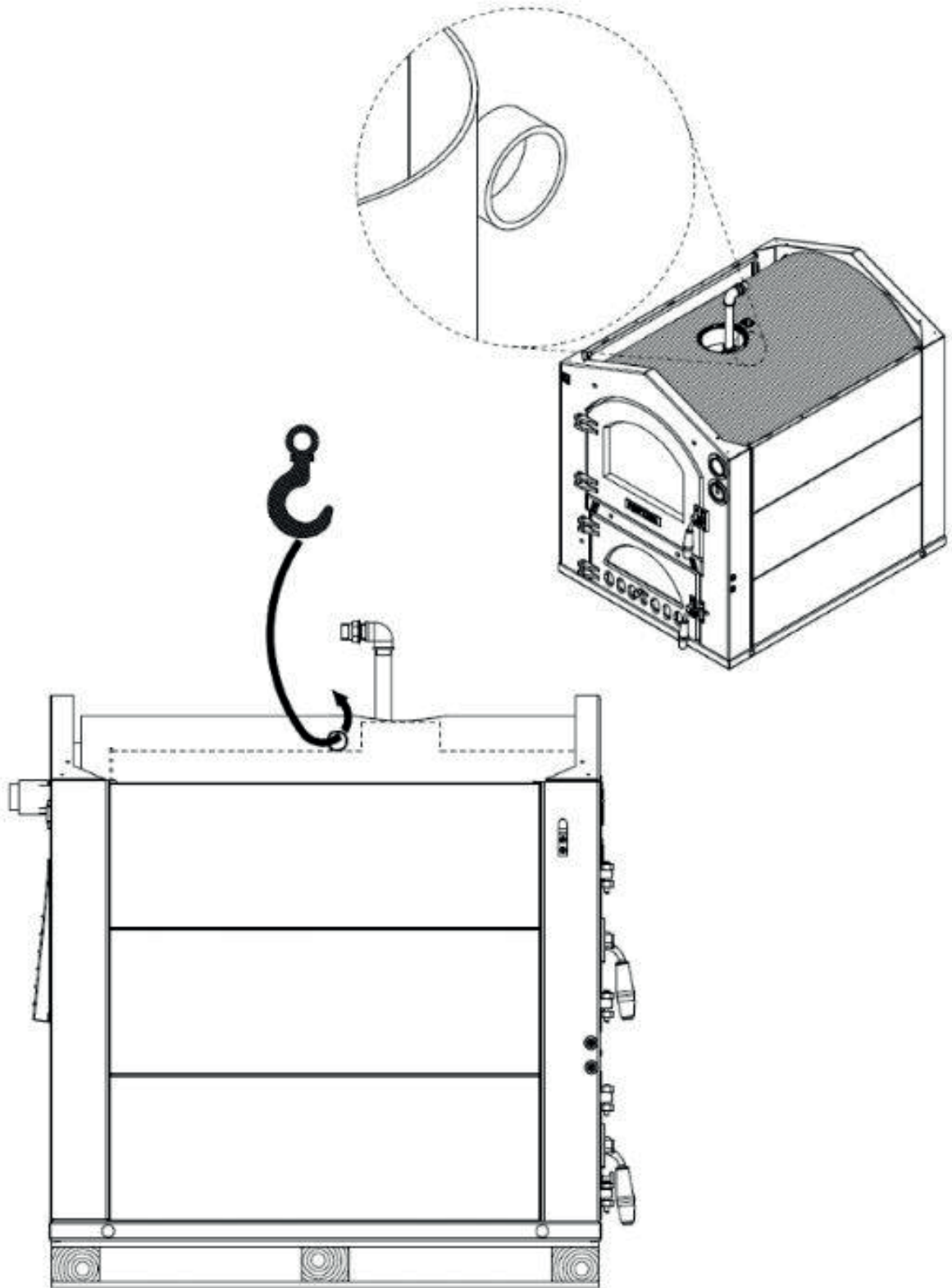

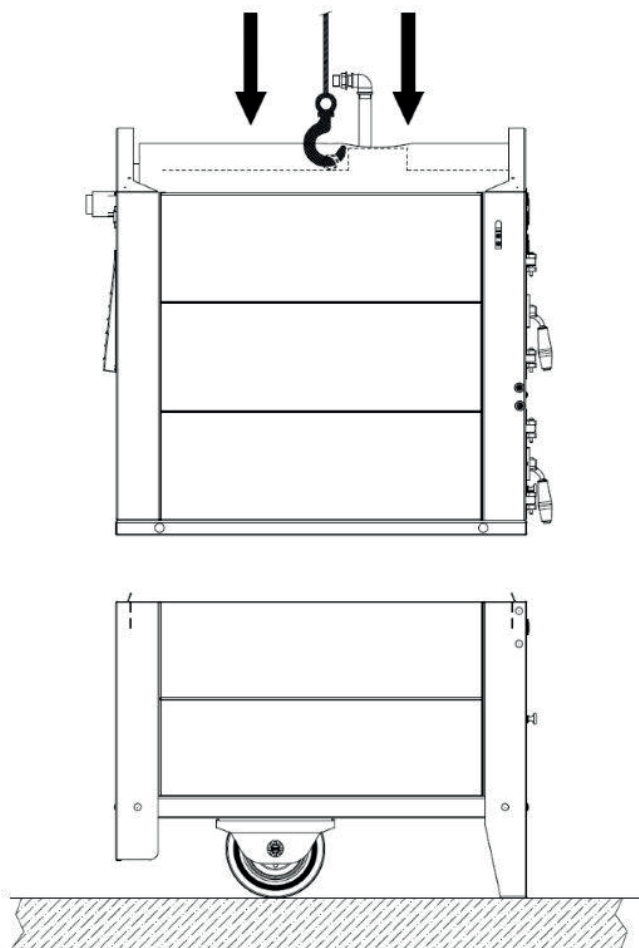
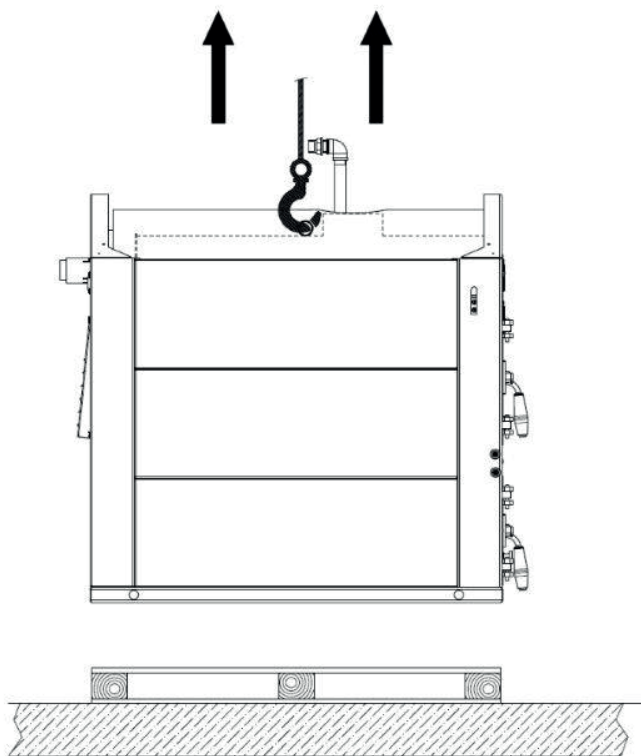

ENG

SECURING THE OVEN ON THE CART

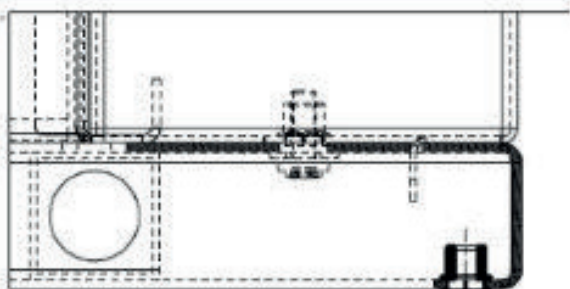
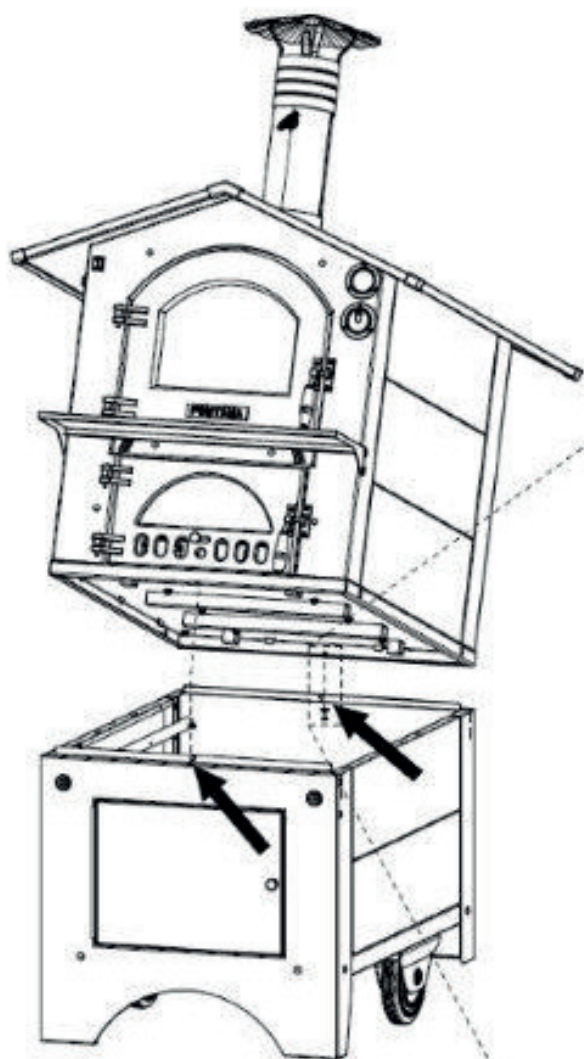

oven

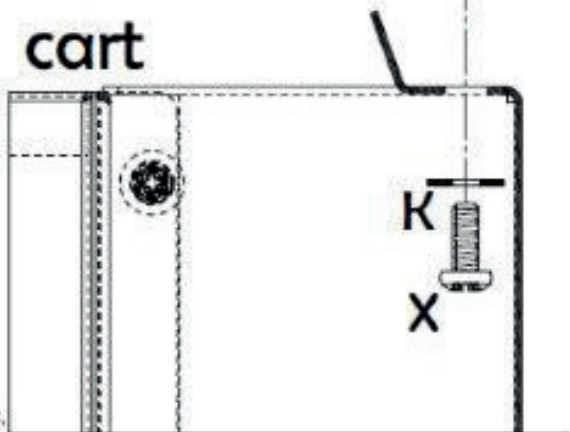

cart



M6x16

X

x2



Ø6/18

K

x2

CLEANING AND MAINTENANCE

Before cleaning, it is necessary to wait for the oven to cool; the electrical connection must be disabled by detaching the plug from the socket or disconnecting the power supply from the main switch of the electrical system.

- Wash the painted or chrome-plated parts with warm water and soap or a non-corrosive liquid detergent.
- For parts in stainless steel, use commonly sold specific products.
- During cleaning operations never use: abrasives, corrosive or acidic detergents.
- Never leave acidic or corrosive substances on painted or stainless steel parts.
- Clean the glass pane of the oven door with warm water only, avoiding the use of abrasive rags.
- "Spray" products for oven cleaning must not be used to clean the fan and protective glass of the lamp.
- Clean the oven after each use: this will make it easy to remove any cooking residue, thus preventing it from burning during subsequent use.
- The glass panes of the combustion chamber and cooking chamber must be cleaned at a cool temperature to avoid excessive thermal shock, which would otherwise place them at risk of breakage.
- When grilling meat, always place a tray (drip pan) under the grate with some water to prevent burning fats from generating smoke and unpleasant odours.
- To eliminate more persistent stains, it is a good idea to use the oven at its maximum temperature of 450°C every now and then in order to burn them, and once the oven has cooled, remove any residual dust with a damp sponge.
- To facilitate internal cleaning operations, it is possible to remove the internal side panels as shown in the photo (in models with this feature).



COOKING SUGGESTIONS

- In order to avoid inconveniences during cooking, it is recommended to open the oven door as little as possible.
- In the case of multiple cooking, make sure to introduce food with approximately the same cooking temperature, albeit differing cooking times.

To heat the oven, it is preferable to use small pieces of dry wood. To reach a temperature of 400°C, approximately 3 kg of wood is required. The temperature will remain constant for about two hours; once the desired temperature is reached, do not leave the flame in the combustion chamber lit, but rather only the embers. If, during cooking, the temperature drops or other food needs to be cooked, the oven can be fed with very little wood. To lower the oven temperature simply open the cooking chamber door. Using this type of oven, quality cooking is possible at a reduced cost.



FOREWORD

Cooking times may vary depending on the nature of the food, its consistency and volume. It is recommended to monitor the first cooking cycles and check the results, in order to achieve similar results when preparing the same dishes in the same conditions.

COOKING BREAD

Light the oven on with some paper and a few small pieces of wood. When the wood has caught fire, add a few larger pieces. Our wood-fired ovens are very efficient and don't need a lot of wood and time to reach temperature. Bring the cooking chamber up to about 300°. Place a small pot of water inside the oven to increase the moisture, because wood-fired ovens tend to be very dry. The humidification of the cooking chamber will delay the premature formation of the crust, which would otherwise prevent the proper internal cooking of the bread.

COOKING PIZZA

If you wish to cook a pizza on the refractory plate, turn the oven on and bring it up to a temperature of about 400°. Place the refractory plate on the lowest shelf and leave it to warm up for about 30 minutes. Then roll out your pizza, transfer it onto a lightly floured pizza peel, top it with tomato and mozzarella, add a drizzle of oil, let it slide onto the plate and cook for 4-5 minutes. It will be even crispier!

If, on the other hand, instead of the refractory plate you'd prefer to bake it on the tray, change both the baking time and temperature used to bake the pizza. In this case, the oven must reach about 450° and the pizza needs to cook for approximately 15/20 minutes.

COOKING MEAT AND FISH

Oven-baked meat needs to weigh at least 1 kg to avoid drying out. Very tender red meat to be cooked rare, in order to properly cook on the outside but still preserve its juices, needs to cook for a short time at a high temperature of 300-350°. For this dish, the total cooking time, based on the quantity of meat reported in the table below, is about 60 minutes.

White meat, poultry and fish need to cook at very low temperatures: 250°-280°C. In this case the cooking times for poultry is about 90 minutes, once again based on the quantity reported in the table below. The cooking time for fish is shorter, normally about 45-60 minutes.

If the cooking time is short, the dressing needs to be applied directly in the tray, otherwise, for long cooking times, it should be added during the final stage of cooking. The level of cooking can be checked by pressing on the meat with a spoon; if it doesn't sink, it means it is cooked at the right level. For roast beef and fillet, which should be pinkish on the inside, the cooking time must be short. The meats can be arranged either on a plate suitable for oven baking (oven pan), on the oven tray or directly on the grille, under which a drip pan must be placed to collect the juices. The dishes, before being served, can be held in the dedicated compartment of the cart (for outdoor models).

BAKING DESSERTS

Desserts need a moderate temperature, normally between 250° and 300°C and require the oven to be pre-heated for about 45/60 minutes. The door must not be opened until at least 3/4 of the baking time has passed. It must be difficult for beaten doughs to detach from the spoon, because any excessive fluidity would pointlessly prolong the baking time. In this case, baking times can vary greatly depending on the type of dessert being baked. It normally takes about 25-40 minutes, depending of course on the quantity of ingredients used to make it.

FORCED CONVECTION COOKING

In forced convection cooking, the heat is transferred to the food by way of pre-heated air made to circulate by force in the oven compartment by a fan located at the back of the oven itself.

Using this method it is possible to cook multiple foods at the same time using the different levels of the oven itself.

The idea of forced convection cooking was inspired by the need to ensure the perfect and even distribution of temperature around the different foods. This is to allow perfect cooking while maintaining the nutritional values of foods at their highest level. In traditional ovens, heat sources are concentrated in certain points, thus making it difficult to properly control the temperature. Heat is in fact transferred by natural convection and radiation, causing the irregular distribution of the temperature and significant thermal fluctuations between the various levels. The insertion of a fan on the back wall of the oven allows the continuous recirculation of hot air across all levels of the oven, and therefore the even and constant distribution of the temperature.

CONSULTATIVE TABLE:

	Quantity	Dish	Cooking level Ventilated °C	Traditional Cooking °C
Bakery		Soft dough	250	290
		Shortcrust pastry	250	290
		Leavened dough	250	290
		Egg white desserts	190	230
		Puff pastry	270	300
Meats	1 Kg	Roast beef	360	360
	1 Kg	Roast veal	290	330
	1 Kg	Roast lamb	250	290
Poultry		Small roasts	250	290
	1 Kg	Turkey	300	330
	2 Kg	Duck	300	330
	1 Kg	Chicken	300	330
Fish		Trout	280	280
	1 Kg	Codfish	250	250
Other		Lasagne	300	300
		Soufflés	280	300
		Puff pastries	300	300
		Pizza (on tray)	400	450
		Bread	300	330



FONTANA
F O R N I

FONTANA FORNI SRL

Via G. di Vittorio 6

61047 San Lorenzo in Campo (PU)

Telefono e fax: 0721 77 66 97 e 73 53 46

fontanaforni@fontanaforni.com

www.fontanaforni.com



FONTANAFORNI