



15" Projective Capacitive 10pt touchscreen

The ProLite T1521MSC-B2 15" touchscreen is based on projected capacitive technology, offering optimal seamless and accurate touch response. Due to its glass overlay, it guarantees high durability, scratch-resistance and perfect picture performance. A solid and steady base supports the touchscreen with an adjustable stand offering up to 70 degree tilt angles. Menu buttons are located on the back of the screen which can be locked to prevent tampering, and includes a handy function to deactivate the touchscreen for cleaning. The ProLite T1521MSC-B2 is an incredibly powerful touch solution, perfect for instore retail purposes.



Touch technology - Capacitive

This technology uses a sensor-grid of micro-fine wires integrated into the glass that covers the screen. Touch is detected because electrical characteristics of the sensor grid change when human finger is placed on the glass. Thanks to the glass overlay this technology is highly durable, and the touch function remains unaffected even if the glass is scratched. It offers perfect picture performance and will work with human finger (also latex gloved) and stylus-pen.



Scratch resistance

Scratch resistance is essential for touch solutions used in public places and schools. This is achieved thanks to a glass overlay covering the screen. It guarantees high durability of the touch function and even more importantly the touch function remains unaffected even if the glass is scratched.

01 DISPLAY CHARACTERISTICS

Design	Edge to edge glass
Diagonal	15", 38cm
Panel	TN
Native resolution	1024 x 768 (0.8 megapixel)
Aspect ratio	4:3
Panel brightness	370 cd/m ²
Brightness	325 cd/m ² with touch
Light transmittance	88%
Static contrast	800:1
Response time (BTB)	8ms
Viewing zone	horizontal/vertical: 170°/160°, right/left: 85°/85°, up/down: 80°/80°
Colour support	16.7mln
Horizontal Sync	31.4 - 60kHz
Viewable area W x H	304 x 228mm
Pixel pitch	0.297mm
Bezel colour and finish	black, matte

02 TOUCH

Touch technology	projective capacitive
Touch points	10 (HID, only with supported OS)
Touch method	stylus, finger, glove (latex)
Touch interface	USB
Supported operating systems	All iiyama monitors are Plug & Play and compatible with Windows and Linux. For details regarding the supported OS for the touch models, please refer to the driver instruction file available in the downloads section.

03 INTERFACES / CONNECTORS / CONTROLS

Analog signal input	VGA x1
Digital signal input	HDMI x1
Audio output	Speakers 2 x 2W

04 FEATURES

Glass thickness	1.2mm
Glass hardness	7H
Water and dust protection	IP65 (front)
OSD key lock	yes

05 GENERAL

OSD languages	EN, DE, FR, ES, IT, RU, JP, NL
Control buttons	Menu, Up/Left auto adjustment button, Down/Right button, Return/Exit button, Power
User controls	picture (backlight, brightness, contrast, sharpness), display (auto adjustment, H position, V position, pixel clock, phase), color (color temp, picture mode), input, audio (volume, mute), other (reset, OSD time, OSD H position, OSD V position, language), information

Plug&Play

DDC2B

06 MECHANICAL

Tilt angle

70° up; 10° down

VESA mounting

75 x 75mm

Cable management system

yes

07 ACCESSORIES INCLUDED

Cables

power, USB, HDMI

Guides

quick start guide, safety guide

Other

AC adapter, mylar sheet (for VESA mount)

08 POWER MANAGEMENT

Power supply unit

external

Power supply

DC 12 V

Power usage

16W typical, 1.5W stand by, 0.5W off mode

09 SUSTAINABILITY

Regulations

CE, EAC, RoHS support, ErP, WEEE, cULus, REACH, UKCA

Energy efficiency class (Regulation (EU) 2017/1369)

E

REACH SVHC

above 0.1%: Lead

10 DIMENSIONS / WEIGHT

Product dimensions W x H x D

340.5 x 308 x 198mm

Weight (without box)

3.5kg

EAN code

4948570120642

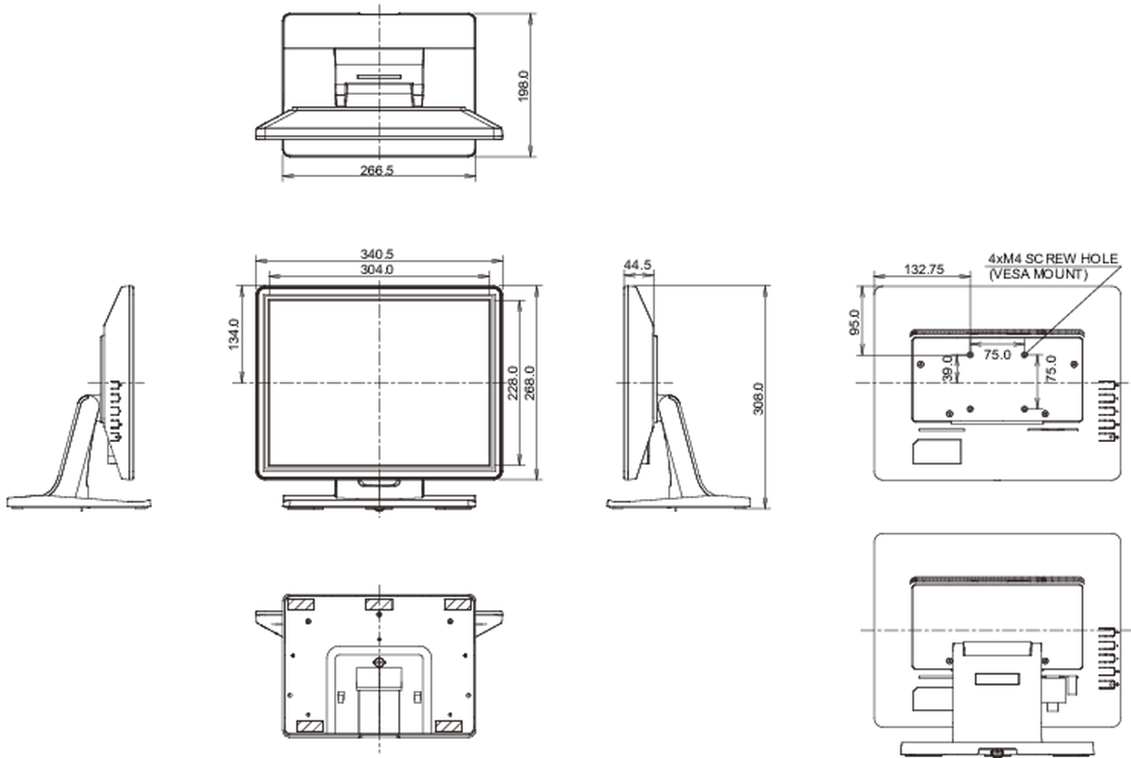

All trademarks and registered trademarks acknowledged. E & O E. Specification subject to change without notice. All LCD's comply with ISO-9241-307:2008 in connection with pixel defects.

© IYAMA CORPORATION. ALL RIGHTS RESERVED