

The Brose e-Bike System

Assembly Instructions



Brose e-Bike System assembly instructions
Reference number: MA_BeBS_v2.0

Contents

1	General Information	5
1.1	Document revision	5
1.2	Reference documents	5
1.3	Symbols used	5

2	Safety Instructions	6
2.1	Safety symbols	6
2.2	Safety instructions	6
2.3	Necessary skills and training	7
2.4	Personal protective equipment	7

3	Assembly	8
3.1	Components	8
3.1.1	Overview of components to be fitted	8
3.2	Fitting the battery pack	9
3.2.1	Fitting the mounting rails	9
3.2.2	Fitting the battery pack	9
3.2.3	Fitting the battery pack connector cable	9
3.3	Drive unit	10
3.3.1	Fitting the drive unit	10
3.4	Cable assignment	11
3.4.1	General information on cable routing	11
3.4.2	Cable assignment plan	11
3.5	Display unit	12
3.5.1	Fitting the holder and display unit	12
3.6	Remote control unit	14
3.6.1	Fitting the remote control unit	14
3.7	Speed sensor and spoke magnet	15
3.7.1	Fitting the speed sensor and spoke magnet	15
3.7.2	Front and rear light	15
3.8	Fitting the motor design covers	16
3.8.1	Right-hand motor design cover	16
3.8.2	Left-hand motor design cover	16
3.9	Fitting the spider, chain ring and groove nut	17
3.9.1	Connecting the spider and chain rings	17
3.9.2	Fitting the spider and chain ring unit	17
3.10	Fitting the crank arms and pedals	18
3.10.1	Fitting the crank arms	18
3.10.2	Fitting the pedals	18

4	Disassembly	19
4.1	Crank arms and pedals	19
4.1.1	Removing the pedals	19
4.1.2	Removing the crank arms	19
4.2	Spider, chain ring and groove nut	20
4.2.1	Removing the spider and chain ring unit	20
4.3	Motor design covers	20
4.3.1	Removing the left- and right-hand motor design covers	20
4.4	Wiring	21
4.4.1	Removing the cables	21
4.5	Drive unit	21
4.5.1	Removing the drive unit	21

5	List of figures	22
6	For your notes	23

1 General Information

1.1 Document revision

The following table shows the revision history for this document. Please make sure that you have the most current version.

Rev.	Changes
15092014_1	Original document
05032017_1	Addition of motor part numbers, reference to different design cover manufacturers

1.2 Reference documents

The following table lists all documents attached to these assembly instructions. They form part of the overall documentation and must be fully observed.

Document	Remark
Design_Manual_2016_08_05	Information on integrating the Brose drive unit into the frame
Operating instructions BDA_BeBS_MY2017_v5.0	Brose e-Bike System operating instructions

1.3 Symbols used



Assembly instructions

Please read the instructions thoroughly prior to assembly and follow the safety instructions.



Information

Indicates important information to be observed in the following sections.



Personal protective equipment

Indicates the personal protective equipment that must be worn in the following steps.



Brose scope of delivery

Indicates the parts or materials from Brose's scope of delivery that are to be used in the following steps.



Tools, auxiliary materials and operating supplies

Indicates the tools, auxiliary materials and operating supplies required for the following steps.



Checkpoints

Indicates checkpoints for verifying that the steps have been completed correctly.

2 Safety Instructions

This section contains safety instructions and information that must be followed at every step. Observing the information contained in this section will ensure safe assembly.

2.1 Safety symbols

This document contains symbols indicating possible sources of danger. They help you identify important safety-related information so that you can act accordingly.



DANGER

Risk of serious injury

Failure to observe this safety information will result in serious injury.



WARNING

Risk of serious injury

Failure to observe this warning may result in serious injury.



WARNING

Risk of serious crush injury

Failure to observe this warning may result in a serious crush injury.



WARNING

Risk of serious injury from electric shock

Failure to observe this warning may result in serious injury caused by an electric shock.

CAUTION

Risk of minor injury or product damage

Failure to observe this warning may result in minor injury or damage to the component or the environment.

2.2 Safety instructions

These safety instructions are designed for your protection and to prevent damage to the product or individual components. Please read them thoroughly before working on the product:

- Please retain all safety instructions and information for future reference.
- Make sure you read and understand the assembly instructions to ensure safe product handling.
- Please observe the safety instructions. Failure to follow these instructions could put you and others at risk.
- All components of this product and its safety devices must be properly assembled to ensure correct operation.
- Alterations and unauthorized modifications to the product and use of unapproved parts are not permitted.
- Always observe applicable national and international safety, health and operating instructions.
- Keep the immediate area clear of highly flammable and other combustible materials.
- Protect the product against unintended activation.
- Disconnect the power supply before starting to assemble the product.
- Keep the work area clear of any tools, objects or cables.
- Always wear suitable personal protective equipment during assembly work.
- Ensure that insulated tools are used at all times for assembly.
- Use only the power supply lines designed for this product.
- Carefully inspect the fully assembled product and check component performance after assembly. Inadequate product assembly or inspection may result in serious injury.
- Never change the component design or state without prior agreement with Brose Drives e-Bike GmbH & Co. KG. Faulty modifications may significantly impair product performance and cause serious injury.
- Make sure only skilled staff can access components that have not been fully mounted.
- Always use suitable tools for pulling connectors out of their sockets.

- Never grab the cables to pull the connectors out of their connection sockets.
- Always use a torque tool for the assembly of bolted joints to prevent damaging aluminum or carbon parts.

2.3 Necessary skills and training

The following conditions must be met to ensure safe operation:

- Make sure all staff receive a safety briefing about possible dangers.
- Only suitably trained and instructed staff should be permitted to carry out assembly work. These employees must have received a special briefing about possible dangers and been issued with appropriate information on the Brose e-Bike System.

2.4 Personal protective equipment

The following protective equipment must be worn to ensure safe operation and assembly:



WARNING

Risk of serious injury

Component handling and commissioning may cause crush injuries to limbs.

- Always wear the protective equipment indicated in the sections.

Explanation of symbols



Personal protective equipment

Indicates the personal protective equipment that must be worn in the following steps.



Safety goggles

Wear suitable eye protection when carrying out the work.



Safety shoes

Wear suitable safety shoes when carrying out the work.



Safety gloves

Wear suitable safety gloves when carrying out the work.



3 Assembly

This section provides a detailed description of how to assemble the Brose e-Bike System. All references to 'left' and 'right' are from the rider's perspective (direction of travel).

3.1 Components

3.1.1 Overview of components to be fitted

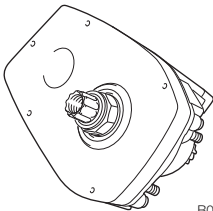
The Brose material number for the relevant component is indicated below the illustrations.

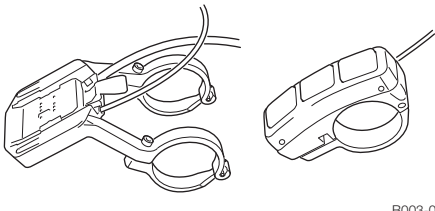
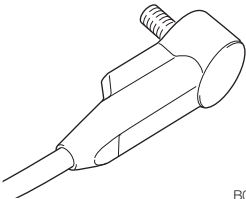
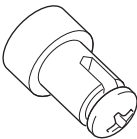
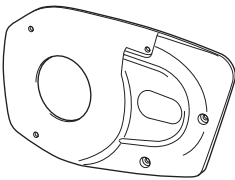
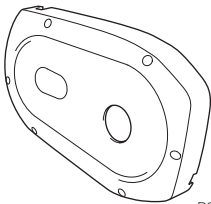
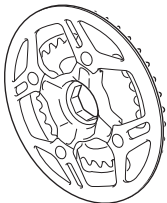
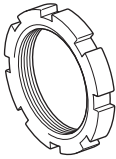
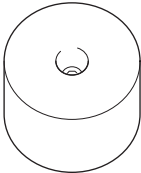
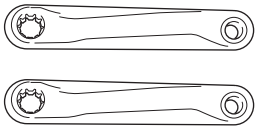
Drive unit	Display unit	Wiring harness display unit + holder + remote control unit	
 <p>B001-0</p> <ul style="list-style-type: none"> - C16162 - C79232 (45 km/h) - C91143 - C97292 (45 km/h) - C97272 - 3 x C34175 	 <p>B002-0</p> <ul style="list-style-type: none"> - C54764 	 <p>B003-0</p> <ul style="list-style-type: none"> - C54760 (with assembly material) 	
Speed sensor	Spoke magnet	Motor design cover right	Motor design cover left
 <p>B004-0</p> <ul style="list-style-type: none"> - C54738 (with assembly material) 	 <p>B005-0</p> <ul style="list-style-type: none"> - C54757 (with assembly material) 	 <p>B006-0</p> <ul style="list-style-type: none"> - Available from different suppliers 	 <p>B007-0</p> <ul style="list-style-type: none"> - Available from different suppliers
Spider and chain rings	Brose groove nut	Brose spider removal cap	Crank arms
 <p>B008-0</p> <ul style="list-style-type: none"> - Available from different suppliers 	 <p>B009-0</p> <ul style="list-style-type: none"> - C13572 	 <p>B010-0</p> <ul style="list-style-type: none"> - C58068 	 <p>B011-0</p> <ul style="list-style-type: none"> - Available from different suppliers

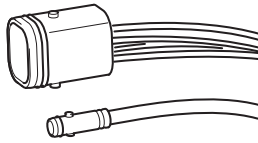

B012-0

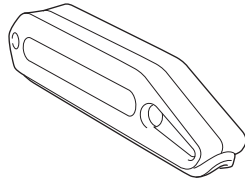

B013-0

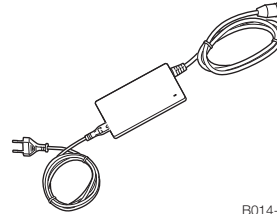

B014-0

- Battery pack, light
 - Different models available
- Different models available
- Different models available

Take all necessary precautions to avoid damaging components, cables and coatings during assembly.



WARNING

Risk of serious injury

Always wear the personal protective equipment indicated during assembly.

- Watch out for rotating components during assembly. Even when idle, they may move and trap limbs, causing crush injuries.

3.2 Fitting the battery pack

The Brose e-Bike System can be combined with different battery packs. Please refer to manufacturer's instructions for details on assembly.

3.2.1 Fitting the mounting rails

Please refer to the manufacturer's instructions for assembling the relevant components.

These instructions do not provide any information about their assembly.

3.2.2 Fitting the battery pack

Please refer to the manufacturer's instructions on fitting and commissioning the battery pack.

These instructions do not provide any information about fitting and commissioning.

3.2.3 Fitting the battery pack connector cable

CAUTION

Risk of product damage

Make sure that the connecting cables are correctly routed in the drive unit housing.

- Do not bend or pinch connecting cables.
- Check the shape coding before assembly.
- Route cables according to your own specifications.

Insert the relevant connectors into the sockets in the drive unit.

- Route cables according to your own specifications.
- For more information, see "Cable assignment" on page 11.

3.3 Drive unit



- Drive unit [C16162, C79232 (45 km/h), C91143, C97292 (45 km/h), C97272]
- 3 x M8 hex serrated flange nut (C34175)



- Torque wrench
- SW 13 nut driver



- M8 hex serrated flange nut = 23 ± 2 Nm

3.3.1 Fitting the drive unit

Make sure the assembly position is correct when fitting the drive unit.

Take care to avoid bending or pinching any existing cables during assembly.

Place drive unit (1) into the drive mount (2) from the right (in direction of travel).

- Make sure that the through holes (A) are lined up.
- Check that the drive unit (1) runs smoothly and has some play after positioning in the drive mount (2).

Use hex nuts (3) to secure drive unit (1).

- Tighten hex nuts (3) with the correct torque.

Cable routing

- Route cables according to your own specifications. For more information, see "Cable assignment" on page 11.

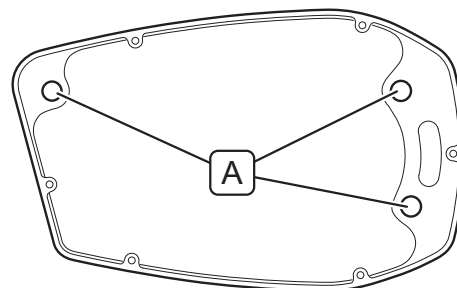
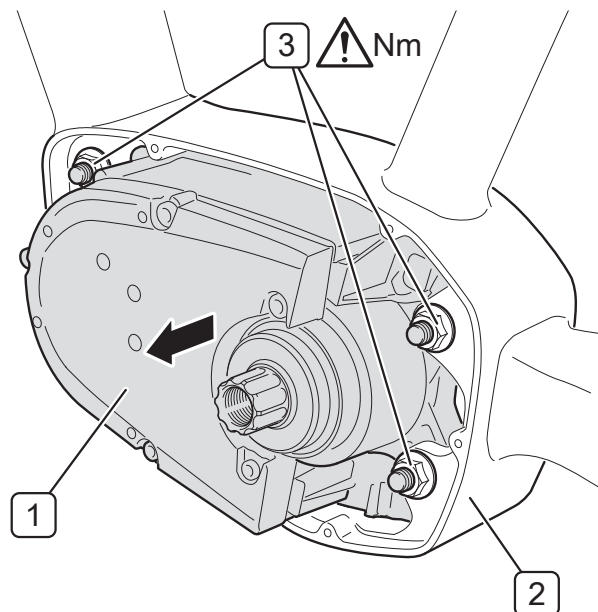

B015-0

3.4 Cable assignment

3.4.1 General information on cable routing

CAUTION

Risk of product damage

Make sure that the connecting cables are correctly routed in the drive unit housing.

- Do not bend or pinch the connecting cables.
- Route cables according to your own specifications.

3.4.2 Cable assignment plan

Select cable length and route cables according to your own specifications.

Overview

- 1) Battery pack
- 2) Rear light
- 3) Front light
- 4) Speed sensor
- 5) Display and remote control unit
- 6) e-Bike

Insert connectors into the sockets in the drive unit.

Observe shape coding.

Insert connector without applying force until it clicks into place.

Use dummy plugs for non-assigned sockets.

- Dummy plugs are available for position 2, 3 and 6.
- Dummy plugs are not shape-coded.

The table on the right-hand side provides an overview of the drive unit's connectors and dummy plugs (front and side view).

- A) Battery pack connector (C50491)
- B) Connector for display and remote control unit (C50492)
- C) e-Bike connector (C50497)
- D) 5-pin dummy plug (C51636)
- E) Front light connector (C50494)
- F) Rear light connector (C50495)
- G) Connector for speed sensor (C50496)
- H) 2-pin dummy plug (C51644)

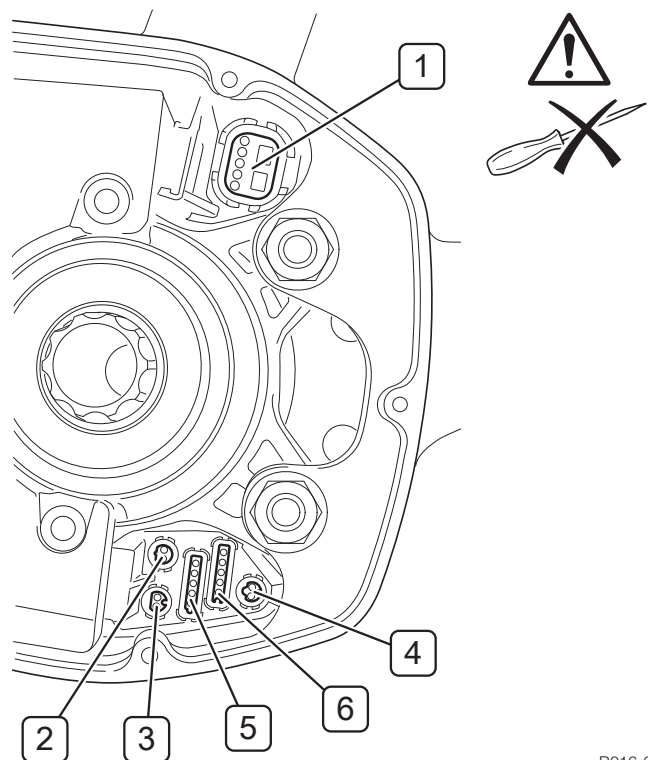

B016-0

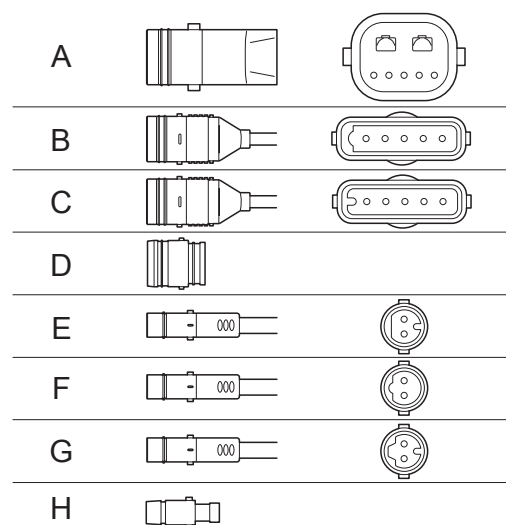

B017-0

3.5 Display unit



- Wiring harness + holder + remote control unit, supplied with 2 x M3x16 hexagon socket screws and 1 x M3x10 hexagon socket screw (lock screw) (C54760)
- Display unit (C54764)



- SW 2.5 hexagon socket wrench
- Torque wrench



- M3x16 hexagon socket screw = 0.5 Nm
- M3x10 hexagon socket screw (lock screw) = 0.3-0.5 Nm
- Suitable for handlebar diameter: 31.8 mm

3.5.1 Fitting the holder and display unit

Check the specified handle bar diameter before assembly.

Use suitable rubber pads for smaller handlebars.

Position clamping brackets (1) in the middle of the handlebar.

- Fold the two halves (2) of the bracket around the handlebar and secure lightly with hexagon socket screws (3).
Align holder and tighten hexagon socket screw (3).
- Check the distance between the clamping brackets is as specified.
- Make sure that you apply the specified torque.

Route cables according to your own specifications and connect with drive unit. For more information, see "Cable assignment" on page 11.

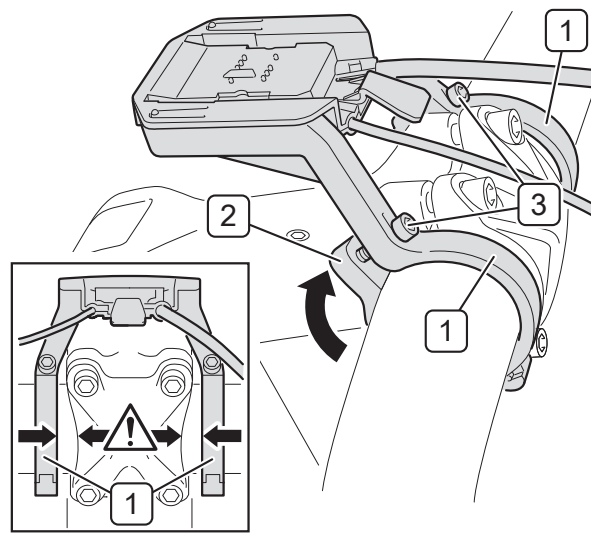

Use guide grooves provided in the holder when mounting the display unit.

Place display unit (4) with guide groove (A) in the guide opening (B) of the holder.

- Push display unit (4) down until it clicks into place.

Optional

- The lock nut prevents unwanted removal of the display unit.
- Screw lock nut (5) into the holder from the bottom.
- Make sure the thread of the lock nut (5) is slightly below the hole and not sticking out.

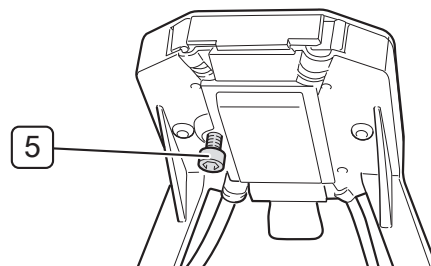
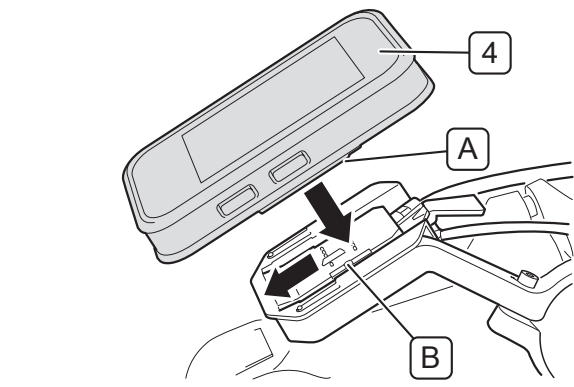

B018-0

The figure on the right-hand side shows the dimensions of the holder for the display unit.

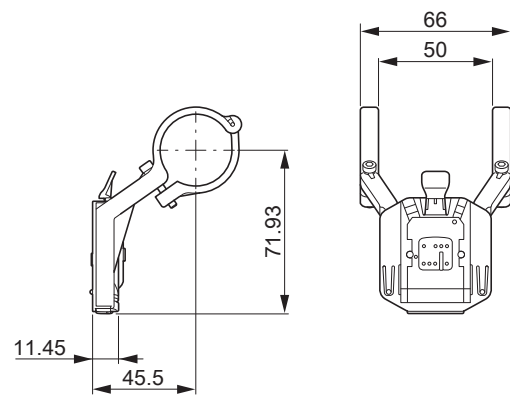

B019-0

3.6 Remote control unit



- Wiring harness + holder + remote control unit, supplied with 2 x M3x16 hexagon socket screws and 1 x M3x10 hexagon socket screw (lock screw) (C54760)



- SW 3 hexagon socket wrench
- Torque wrench



- M4x12 hexagon socket screw = 0.1-0.3 Nm
- Suitable for handlebar diameter: 22.2 mm

3.6.1 Fitting the remote control unit

Check the specified handlebar diameter before assembly.

The remote control unit can be positioned on the left or right side of the handlebar.

Run the cable (2) from the remote control unit (1) according to the required handlebar position.

Right handlebar position

Run the cable (2) from the left side of the remote control unit (1).

Left handlebar position

Run the cable (2) from the right side of the remote control unit (1).

Position remote control unit (1) on handlebar.

- The screw connection faces away from the direction of travel.

Fold clamping bracket (3) around handlebar.

Secure remote control unit (1) with hexagon socket screw (4).

- Make sure that you apply the specified torque.

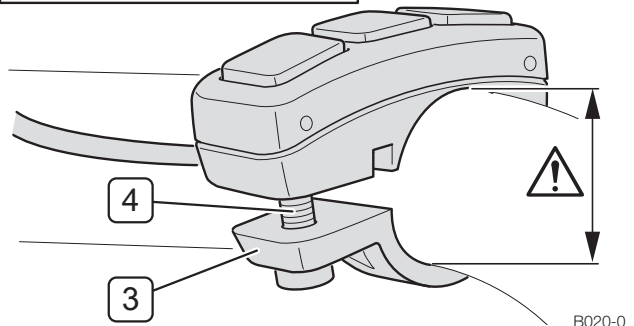
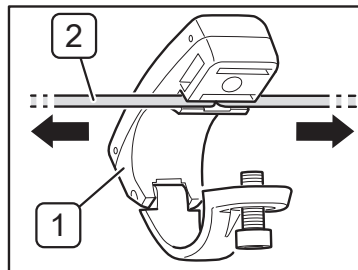

B020-0

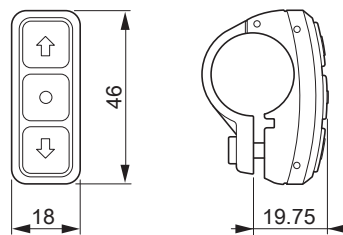

B021-0

3.7 Speed sensor and spoke magnet



- Speed sensor with M5x12 Torx screw (C54738)
- Spoke magnet with M4x6 cross-recessed screw (C54757)



- Torque wrench
- Torx T 20
- PH02 cross-recessed screw drive



- M5x12 Torx screw = 0.8 Nm
- M4x6 cross-recessed screw = 3 Nm
- Optimal distance speed sensor/spoke magnet = 5-17 mm

3.7.1 Fitting the speed sensor and spoke magnet

The speed sensor can only be fitted into the appropriate frame mount adapter.

Remove protective cap (1).

Place speed sensor (2) into the frame mount adapter on the left chainstay.

Secure speed sensor (2) with Torx screw (3).

Replace protective cap (1).

Line spoke magnet up with slot (5) on spoke.

- The flat side of the spoke magnet (5) should be facing the speed sensor (2).
- Center spoke magnet (5) along the line marking and secure with cross-recessed screw (4).
- Route cables according to your own specifications and connect to drive unit.
- For more information, see "Cable assignment" on page 11.

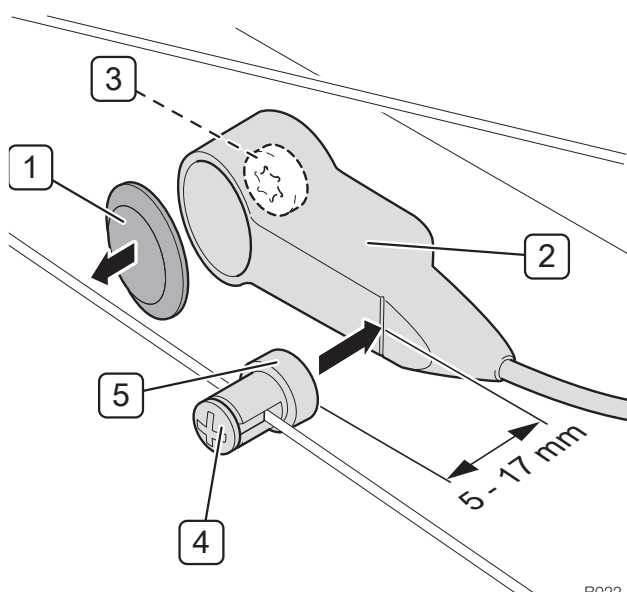

B022-0

3.7.2 Front and rear light

CAUTION

Risk of product damage

Make sure that the connecting cables are correctly routed in the drive unit housing.

- Do not bend or pinch connecting cables.
- Route cables according to your own specification.

Insert the relevant connectors into the sockets in the drive unit.

- Route cables according to your own specifications.
- For more information, see "Cable assignment" on page 11.

3.8 Fitting the motor design covers



- Right-hand motor design cover with 3 x M4x8 hexagon socket screws and 2 x M4x6 hexagon socket screws or follow design cover manufacturer's specification
- Left-hand motor design cover with 6 x M4x30 hexagon socket screws or follow design cover manufacturer's specification



- SW 3 hexagon socket wrench
- Torque wrench



- M4x6 hexagon socket screw = 0.1-0.3 Nm
- M4x8 hexagon socket screw = 0.1-0.3 Nm
- M4x30 hexagon socket screw = 0.1-0.3 Nm

3.8.1 Right-hand motor design cover

All references to 'left' and 'right' are from the rider's perspective.

Position the motor design cover (2) so that the screw holes line up.

Use M4x8 (1a) and M4x6 (1b) hexagon socket screws to attach the motor design cover to the drive unit.

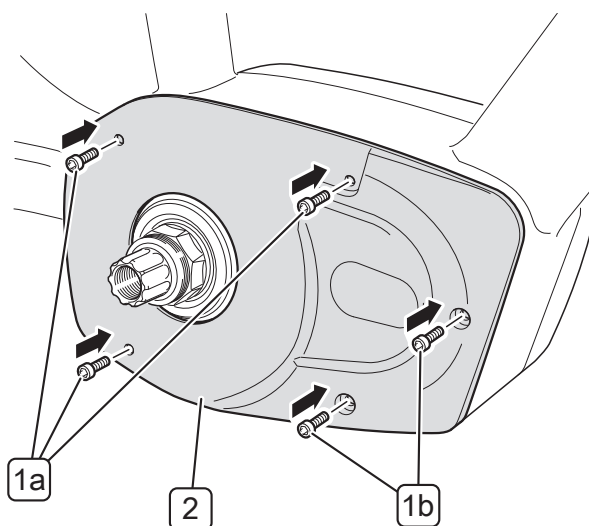

B023-0

3.8.2 Left-hand motor design cover

All references to 'left' and 'right' are from the rider's perspective.

- Check that the cables are correctly routed before fitting the motor design cover (1).

- For more information, see "General information on cable routing" on page 11.

Position the motor design cover (1) so that the screw holes line up.

Use M4x30 hexagon socket screws (2) to attach the motor design cover (1) to the drive unit.

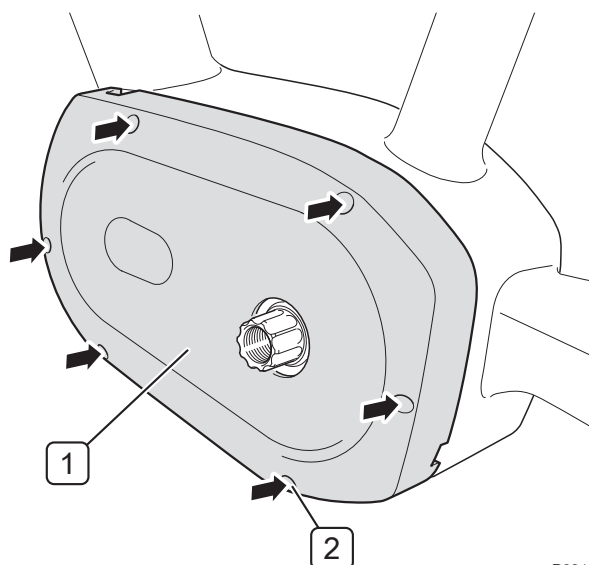

B024-0

3.9 Fitting the spider, chain ring and groove nut



- Brose groove nut (C13572)



- Torque wrench
- Bottom bracket tool for ISIS bottom bracket



- Brose groove nut = 25-30 Nm

3.9.1 Connecting the spider and chain rings

Assemble spider and chain rings according to manufacturer's specifications.

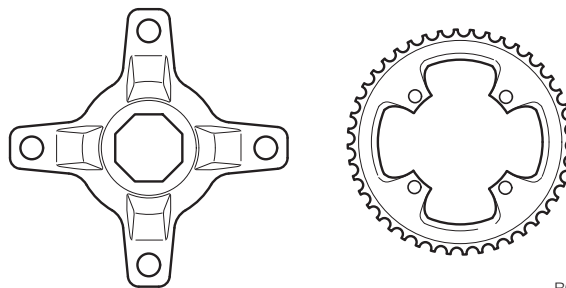

B025-0

3.9.2 Fitting the spider and chain ring unit

- Make sure that you apply the specified torque.
- Mount pre-assembled unit consisting of spider and chain ring (1) on drive shaft (2).
- Screw on Brose groove nut (3) and secure with bottom bracket tool.
- Mount drive chain according to your own specifications.

Optional

For double chain rings, mount front derailleur according to manufacturer's specifications.

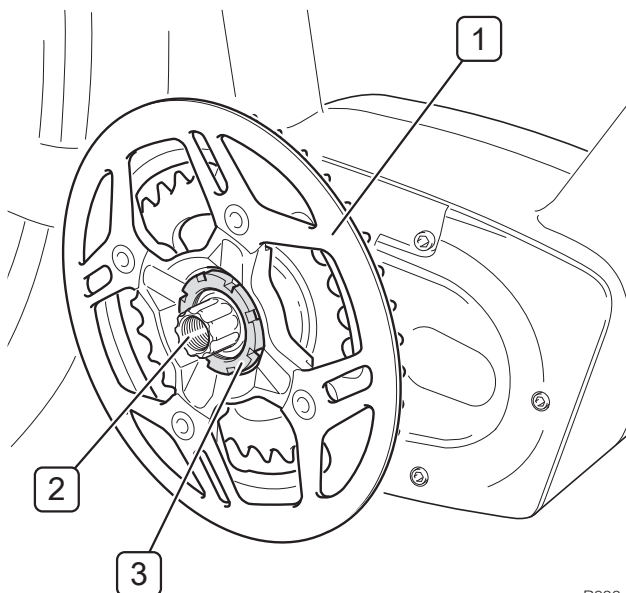

B026-0

3.10 Fitting the crank arms and pedals



- Torque wrench
- SW 8 hexagon socket wrench



- Hexagon socket screw (dimensions and torque according to manufacturer's specifications)

3.10.1 Fitting the crank arms

Before fitting the crank arms, check that you have the correct side.

Apply a small quantity of grease to the ISIS connection (1).

Place crank arm (2) on drive shaft.

Secure crank arm (2) with hexagon socket screw (3).

- Make sure that you apply the specified torque.

Repeat these steps to fit the second crank arm.

- Check for proper meshing and correct positioning of second crank arm (offset by 180°).

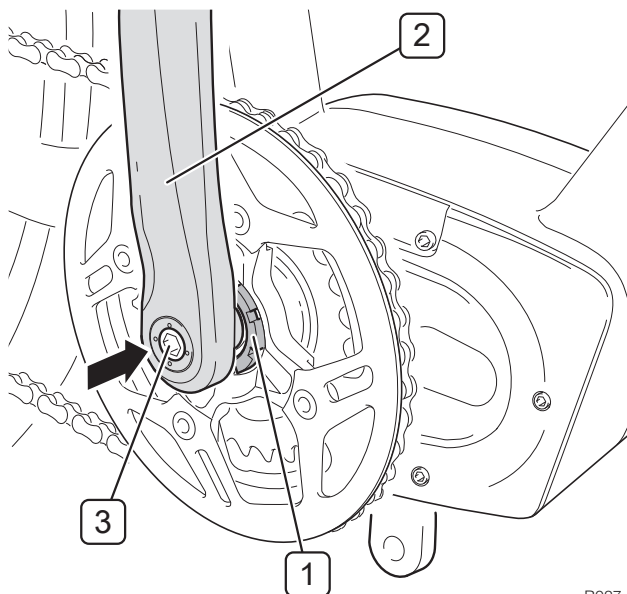

B027-0

3.10.2 Fitting the pedals

Before fitting the pedals, check that you have the correct side.

Fit pedals according to manufacturer's specifications.

4 Disassembly



DANGER

Risk of electric shock

Disconnect the power supply before starting to disassemble the product.

Remember to always remove the battery pack before working on the Brose e-Bike System.

Take care not to damage components, cables and coatings during disassembly. The referenced sections mainly relate to specified tools and work steps and are intended for guidance only.

4.1 Crank arms and pedals



- SW 8 hexagon socket wrench
 - Standard puller if necessary
-

4.1.1 Removing the pedals

Remove pedals according to manufacturer's specifications.

4.1.2 Removing the crank arms

Please follow the manufacturer's instructions when removing the crank arms.

Loosen hexagon socket screws and remove crank arms on both sides.

- Use standard puller if necessary.
- For more information, see "Fitting the crank arms" on page 18.

4.2 Spider, chain ring and groove nut



- Brose groove nut (C13572)



- Bottom bracket tool for ISIS bottom bracket
- Standard puller

4.2.1 Removing the spider and chain ring unit

Please follow the manufacturer's instructions when removing the spider and chain ring unit.

Loosen Brose groove nut with ISIS bottom bracket tool and remove.

Place Brose spider removal cap on hollow shaft.

Position puller between spider arms.

- Loosen spider and chain ring unit and remove.
- For more information, see "Fitting the spider and chain ring unit" on page 17.

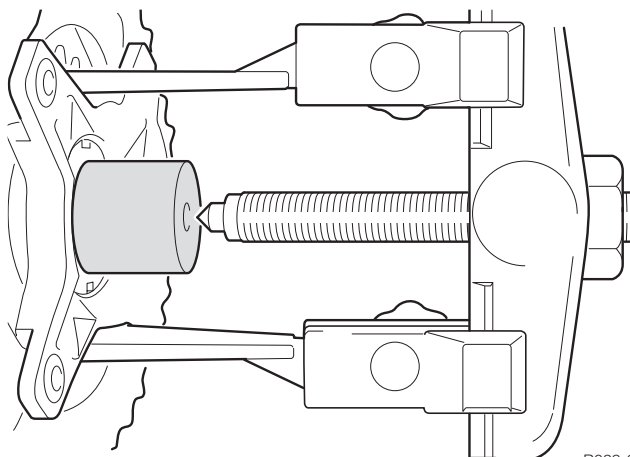

4.3 Motor design covers



- Right-hand motor design cover with 3 x M4x8 hexagon socket screws and 2 x M4x6 hexagon socket screws or follow design cover manufacturer's specification
- Left-hand motor design cover with 6 x M4x30 hexagon socket screws or follow design cover manufacturer's specification



- SW 3 hexagon socket wrench

4.3.1 Removing the left- and right-hand motor design covers

Secure motor design covers before loosening the hexagon socket screws to prevent them from falling and getting damaged.

Loosen and remove hexagon socket screws on both sides.

- For more information, see "Right-hand motor design cover" on page 16.
- For more information, see "Left-hand motor design cover" on page 16.

4.4 Wiring

CAUTION

Risk of product damage

Never grab the cables to pull the connectors out of their connection sockets.

4.4.1 Removing the cables

Pull connectors out of the connection sockets by hand or using a suitable tool.

- For more information, see “Cable assignment” on page 11.

4.5 Drive unit



- Drive unit [C16162, C79232 (45 km/h), C91143, C97292 (45 km/h), C97272]
- 3 x M8 hex serrated flange nut (C34175)



- SW 13 nut driver

4.5.1 Removing the drive unit

Take care not to bend or pinch any existing cables when removing the drive unit.

- For more information, see “General information on cable routing” on page 11.
Ensure drive unit is protected from falling before loosening the hex nuts.
Loosen and remove hex nuts.
- SW 13 nut driver
Remove drive unit from the right side of the drive mount.

CAUTION

Risk of product damage

If you cannot remove the drive unit or only with great difficulty, tap it gently with a rubber mallet. Do not tap on the motor housing or bottom bracket to avoid damaging the electronics and sensors. The following illustration shows the areas (A) that can be safely tapped with a rubber mallet or other suitable tool.

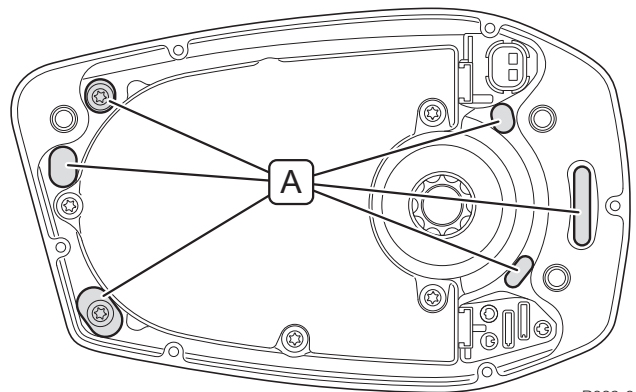

B029-0

- For more information, see “Drive unit” on page 10.

5 List of figures

Figure	Section	Heading	Page
B001-0	3.1.1	Overview of components to be fitted - Drive unit	8
B002-0	3.1.1	Overview of components to be fitted - Display unit	8
B003-0	3.1.1	Overview of components to be fitted - Wiring harness display unit + holder + remote control unit	8
B004-0	3.1.1	Overview of components to be fitted - Speed sensor	8
B005-0	3.1.1	Overview of components to be fitted - Spoke magnet	8
B006-0	3.1.1	Overview of components to be fitted - Motor design cover right	8
B007-0	3.1.1	Overview of components to be fitted - Motor design cover left	8
B008-0	3.1.1	Overview of components to be fitted - Spider and chain rings	8
B009-0	3.1.1	Overview of components to be fitted - Brose groove nut	8
B010-0	3.1.1	Overview of components to be fitted - Brose spider removal cap	8
B011-0	3.1.1	Overview of components to be fitted - Crank arms	8
B012-0	3.1.1	Overview of components to be fitted - Wiring harnesses	9
B013-0	3.1.1	Overview of components to be fitted - Battery pack	9
B014-0	3.1.1	Overview of components to be fitted - Battery charger	9
B015-0	3.3.1	Fitting the drive unit	10
B016-0	3.4.2	Cable assignment plan	11
B017-0	3.4.2	Cable assignment plan	11
B018-0	3.5.1	Fitting the holder and display unit	12
B019-0	3.5.1	Fitting the holder and display unit	13
B020-0	3.6.1	Fitting the remote control unit	14
B021-0	3.6.1	Fitting the remote control unit	14
B022-0	3.7.1	Fitting the speed sensor and spoke magnet	15
B023-0	3.8.1	Right-hand motor design cover	16
B024-0	3.8.2	Left-hand motor design cover	16
B025-0	3.9.1	Connecting the spider and chain rings	17
B026-0	3.9.2	Fitting the spider and chain ring unit	17
B027-0	3.10.1	Fitting the crank arms	18
B028-0	4.2.1	Removing the spider and chair ring unit	20
B029-0	4.5.1	Removing the drive unit	21

6 For your notes

Brose Antriebstechnik GmbH & Co. KG, Berlin
Sickingenstr. 29-38
10553 Berlin
+49 30 343498 100
+49 30 343498 122
ebike.berlin@brose.com
www.brose-ebike.com