

# child trailer

Burley d'lite™ ST and Solo™ ST

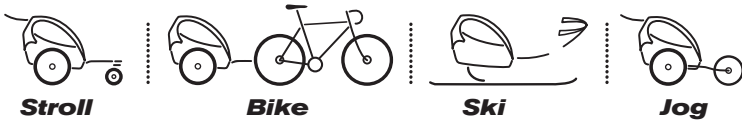

Burley d'lite™ ST model shown





## Owner's Instruction and Safety Manual

Burley d'Lite™ ST and Solo™ ST

## Contents

3	Introduction
3	Safety Guidelines
3	Parts Bag Contents
3	Tools Required
4	Installing Tow Bar Clamps
4	Opening and Closing Your Trailer
5	Attaching the Seat
5	Attaching Wheels
6	Using Parking Brake
6	Installing Tow Bar
7	Using Your Stroller
7	Adjusting Stroller Wheel Tracking
8	Installing Cover
8	Attaching Handle
8	Installing Safety Flag
9	Installing Seat Pads
9	Installing Shoulder Harness and Crotch Strap Pads
9	Using Seat Harness
10	Using Seat Recliner
10	Hitching Trailer to Your Bicycle
11	Safety Checklists
11	Maintenance and Storage
12	d'Lite ST and Solo ST Replacement Parts List
13	d'Lite ST and Solo ST Replacement Parts Diagram
16	Warranty

## Congratulations!

Your Burley® trailer is the leading choice of refined bicycle trailer owners worldwide. Every effort has been made to ensure your purchase is a top-quality, thoroughly-tested design, ready to provide many years and miles of happy, safe trailering.

Please go to [www.burley.com](http://www.burley.com) or contact us at [burley@burley.com](mailto:burley@burley.com) to register your warranty information.

### IMPORTANT

IT IS VERY IMPORTANT FOR YOU TO FAMILIARIZE YOURSELF WITH YOUR BURLEY BY READING THIS ENTIRE MANUAL BEFORE USE. IF YOU HAVE ANY QUESTIONS, PLEASE CONTACT YOUR AUTHORIZED BURLEY DEALER OR VISIT [WWW.BURLEY.COM](http://WWW.BURLEY.COM).

## Introduction

Once you've done the initial assembly and read the safety guidelines, you're ready to go! Before trailering, be sure you have the safety harness, seat belt, tow bar, trailer wheels and hitch securely attached.

**NOTE:** Any reference to left or right is made in direction of travel, as if you were standing behind the trailer, looking forward.

## Safety Guidelines

### WARNING

BICYCLING WITH A TRAILER, AND BICYCLING IN GENERAL, CAN BE HAZARDOUS. FAILURE TO OBSERVE ANY OF THE SAFETY GUIDELINES IN THIS MANUAL COULD RESULT IN AN ACCIDENT AND SERIOUS INJURY OR DEATH.

1. Inspect and maintain your bicycle and trailer regularly. See "Safety Checklists" on page 11.
2. Because of the trailer's additional weight, a bicycle pulling a trailer is heavier and less responsive. Avoid sudden swerving, rocks and curbs. Experiment with the loaded trailer in an uncongested area until you become familiar with it.
3. The total weight limit for the trailer, children and/or cargo is 75 lbs (34 kg) for single passenger trailers and 100 lbs (40 kg by law in Europe) for double passenger trailers. Load children and/or cargo securely in the center of the trailer, forward of the axle and as low as possible.
4. The trailer seat is intended for 1 or 2 children who are old enough to wear a helmet, sit upright without physical support, and with adequate neck strength to hold their heads upright while trailering, unless using Burley-approved infant accessory seat. A physician should evaluate anyone who is of questionable developmental age for trailering.

**NOTE:** Go to [www.burley.com](http://www.burley.com) to see Burley's line of infant seats and adapters for younger children.

5. The maximum age for passengers is 6 years. Never carry children whose seated height (with helmet) exceeds 4 inches (100mm) below the internal roll bar.
6. Fasten the seat belt and shoulder harnesses so that each child is held securely. Seat a single child in the center. Periodically check the placement of the shoulder straps, especially on sleeping children.
7. Make sure children cannot put a finger into the wheel spokes.
8. Instruct children not to bounce or lean, as a weight shift could cause the trailer to tip over.
9. To protect children from flying debris, always use your cover. Never leave children unattended. Check children frequently, especially during hot or cold weather.
10. Observe recommended speed limits: a maximum of 15 mph (24 km/h) on smooth, straight roads and 5 mph (8 km/h) or less when turning or on uneven roads.
11. Set your parking brake before removing your children or cargo.
12. Never pull your trailer with a motorized vehicle.
13. The cyclist and passengers must wear helmets.
14. Only use factory-supplied wheels, with the tires inflated to the pressure recommended on the tire side wall. Check pressure before each use. Do not use higher-pressure or knobby tires.
15. Clamp the hitch securely to the bicycle frame, and check for a tight attachment before each ride.
16. Use the safety flag.
17. Do not make alterations to the trailer. Contact your Authorized Burley Dealer or go to [www.burley.com](http://www.burley.com) for replacement of any damaged, worn-out or missing parts.
18. Do not use your trailer on icy roads or when inclement weather makes cycling hazardous.
19. The use of a mirror on your bicycle is recommended.
20. For emergencies, breakdowns or flat tires, pull completely off the road and move your children to a safe area before doing repairs.

### Parts Bag Contents:

(1) Burley Owner's Instruction and Safety Manual

(1) Hitch

(1) Pair of tow bar mount clamps

(2) Bolts

(2) Nuts

Tools Required: 4mm hex key wrench

10mm open end socket wrench

**NOTE:** The tow bar mount clamps also function as wheel guards. They will be referred to as clamps in these assembly instructions.

## **⚠️ WARNING**

TRAILERS CAN TIPOVER, CAUSING DAMAGE TO TRAILER AND SERIOUS INJURY TO PASSENGERS. AVOID CAUSES OF TIPOVER, ESPECIALLY:

- CHILDREN LEANING OR BOUNCING
- HITTING POTHOLES, CURBS, OTHER ROAD OBSTRUCTIONS
- TAKING TURNS TOO FAST
- SUDDEN SWERVING
- IMPROPER WHEEL INSTALLATION OR TIRE INFLATION

### Installing Tow Bar Clamps

1. On left front corner of trailer, match hole in left clamp to hole in tow bar mount and insert bolt from the top through holes.
2. Using hex key wrench on top and socket wrench on bottom, tighten nut securely on bolt end. PHOTO 1
3. Repeat process to install right clamp on right front corner.

### Opening and Closing Your Trailer

1. Rotate front tube upward and rear tube back until they meet on plastic saddles. FIGURE 1
2. Rotate frame locks and snap onto rear tube. FIGURE 2
3. To close trailer, unclip seat buckles on back of seat and reverse opening process.

NOTE: To allow folding, the side battens in the d'Lite ST trailer are not attached to the sides in the rear.

 To view a video clip of "Folding a Burley" go to: [www.burley.com/support/tutorials.cfm](http://www.burley.com/support/tutorials.cfm).

## **⚠️ WARNING**

CHECK THAT THE FRAME LOCKS ARE PROPERLY ENGAGED BEFORE USING THE TRAILER. FAILURE TO DO SO CAN RESULT IN SERIOUS INJURY.

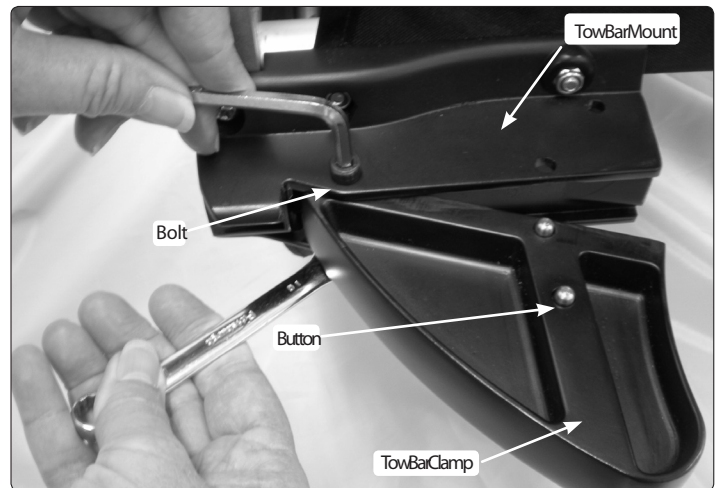

PHOTO 1: Left trailer side

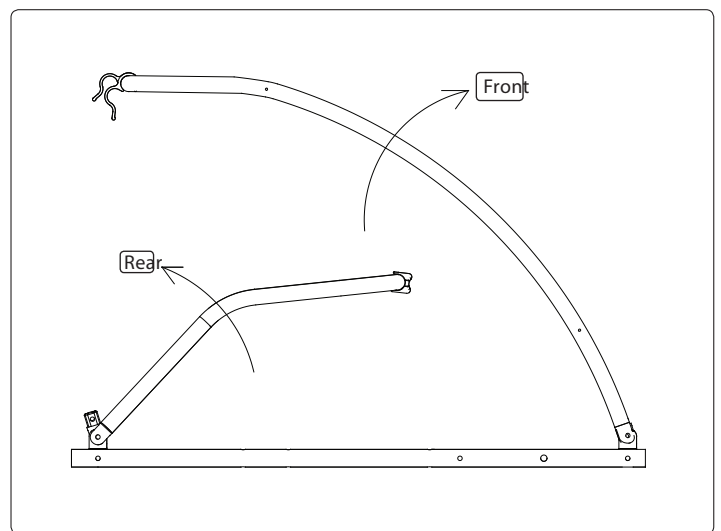

FIGURE 1

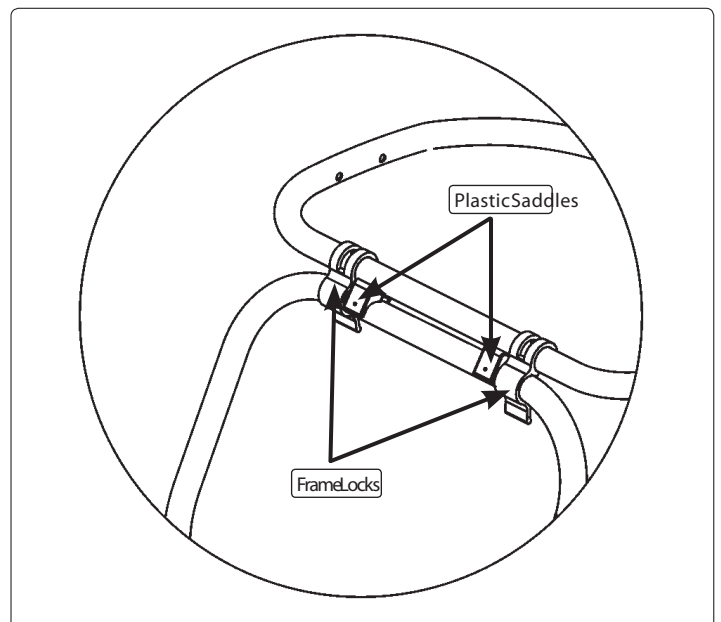

FIGURE 2

## Attaching the Seat

1. Behind seat, fasten buckle sections together on upper and lower straps and adjust as needed. PHOTO 2
2. Attach hooks on seat sides to D-rings by windows (d'Lite ST). PHOTO 3
3. To close the trailer, unfasten buckles behind seat.

## IMPORTANT

ALWAYS KEEP SEAT ATTACHMENTS FASTENED WHILE TRAILERING.

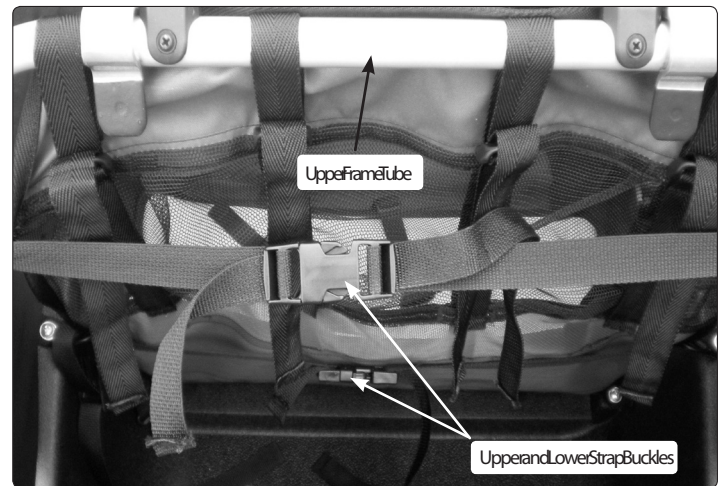

PHOTO 2: Back of d'Lite ST seat shown

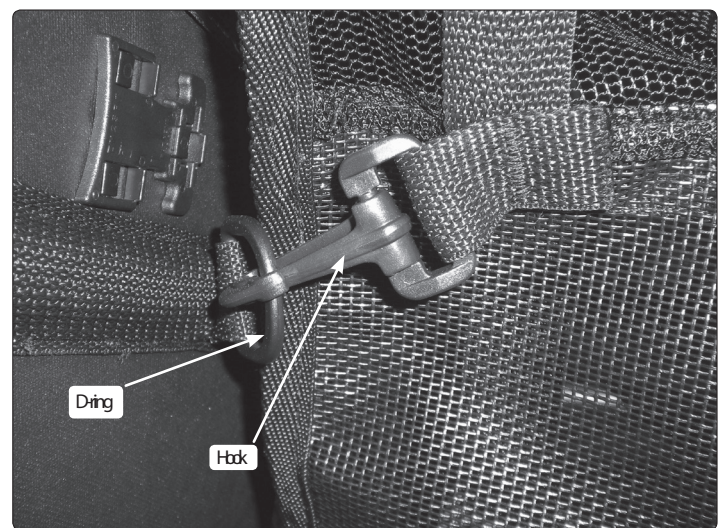

PHOTO 3: Seat sides

## Attaching Wheels

1. Push rubber button on outside of wheel hub.
2. Insert axle fully into axle receiver and release button. PHOTO 4
3. Pull firmly on wheel to check that axle is fully engaged.

## ⚠ WARNING

MAKESUREWHEELSAREHELDSECURELY,WITHWHEELSHAFT FULLYINSERTEDINTOAXLERECEIVER.YOUSHOULDNOTBE ABLETO ROCKOR SHIFTWHEELS.IMPROPERLY INSTALLED WHEELS CAN FALL OFF, CAUSING AN ACCIDENT OR SERIOUS INJURY.

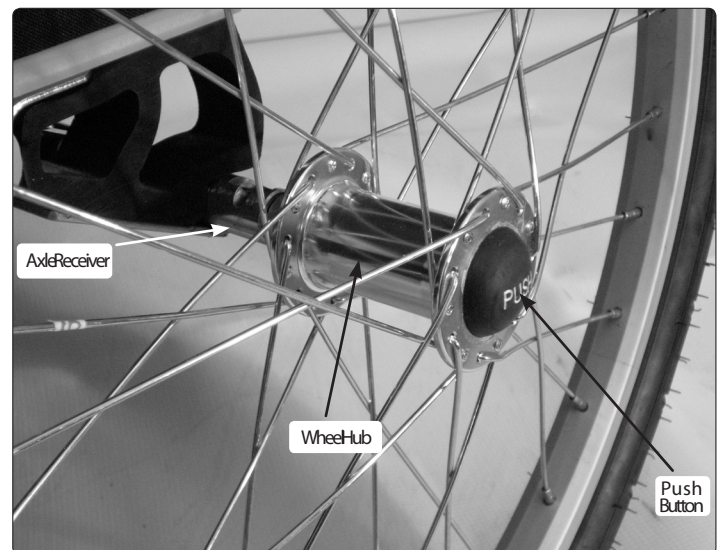

PHOTO 4

## Using Parking Brake

Engage parking brake by pushing handle to the right. Exercise caution when disengaging brake, as it may spring to the left. PHOTO 5

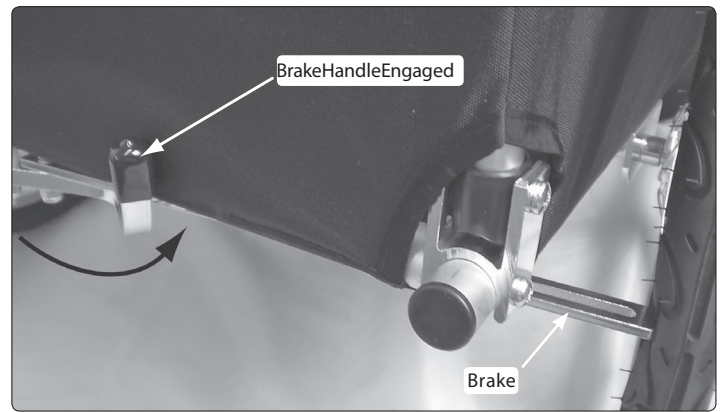

PHOTO 5

## Installing Tow Bar

1. On left side of trailer, depress buttons on top and bottom of tow bar clamp and swing clamp partially open.

NOTE: When installing tow bar, do not swing the clamp all the way open. PHOTO 6

2. Slowly slide tow bar into tow bar mount until the detent clicks into place. PHOTO 6
3. Pull on tow bar to check that it is completely locked in place.
4. Install retaining pin. PHOTO 7
5. Close clamp firmly, making sure clamp latch is engaged. PHOTO 7
6. To remove tow bar, remove retaining pin, pull clamp all the way open and slide tow bar out of mount. PHOTO 8

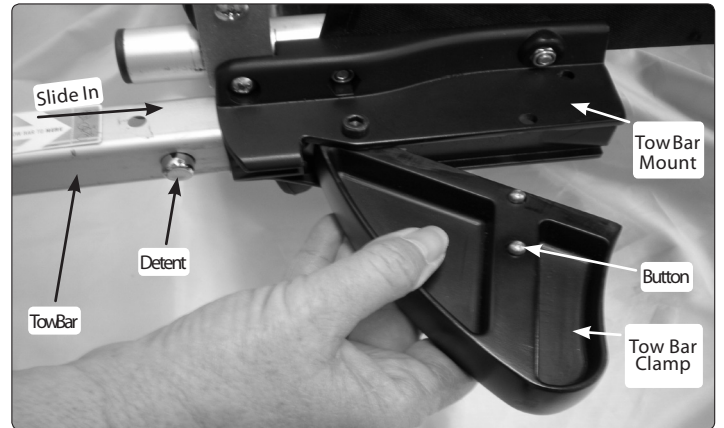

PHOTO 6: Install tow bar

## WARNING

NEVER OPERATE TRAILER WITHOUT TOW BAR CLAMP LOCKED IN PLACE. AN UNLOCKED TOW BAR CAN LOOSEN OR DETACH, CAUSING ACCIDENT RESULTING IN SERIOUS INJURY.

Burley Jogger and We! Ski can add to your trailering fun! Go to [www.burley.com](http://www.burley.com) to check out the Burley accessory kits available for your trailer.

To install the tow bar when using these accessories: For the Burley Jogger and We! Ski Kits, follow the instructions above.

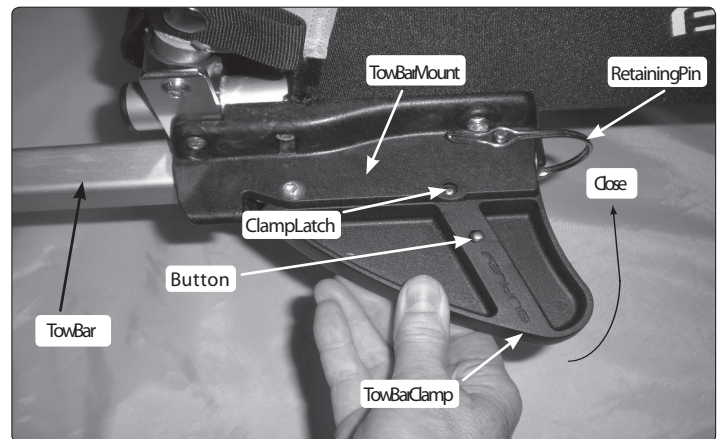

PHOTO 7: Lock tow bar in place

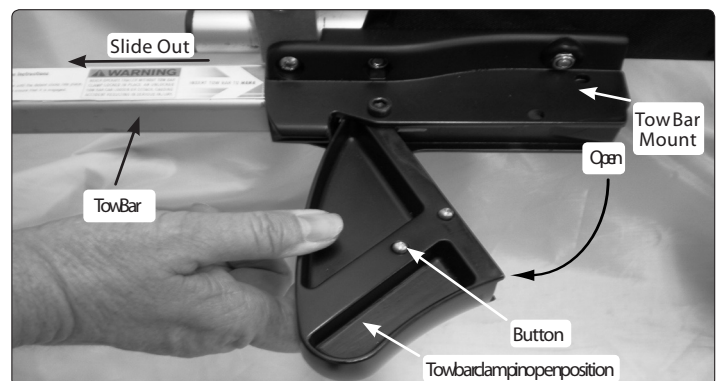



PHOTO 8: Removing tow bar

## Using Your Stroller

1. Loop tether around handle bar center, slide strap end through small loop on other end of strap and tighten securely. PHOTO 9
2. Engage parking brake.
3. Place stroller wheel in "Stroll" position and secure by tightening knob. PHOTO 10
4. Slide tow bar into left tow bar mount as far as it will go and then close clamp firmly, making sure clamp latch is engaged. PHOTO 11

NOTE: Retaining pin is not used for the "Stroll" position.

5. Push trailer to test stroller wheel tracking. If trailer does not roll straight, adjust wheel tracking.

 To view a video clip of "Convert from Trailering to Strolling" go to: [www.burley.com/support/tutorials.cfm](http://www.burley.com/support/tutorials.cfm).

## Adjusting Stroller Wheel Tracking

NOTE: For best results, adjust with trailer fully loaded.

Tool Required: 5mm hex wrench (provided), 25mm (1") wrench

1. With stroller wheel secured in "Stroll" position, loosen bolt using 5mm hex wrench. FIGURE 3
2. Using a 25mm wrench, turn bushing so that stroller wheel is vertical when viewed from front.
3. Fine tune as necessary so that trailer rolls straight.
4. Tighten bolt.

 To view a video clip of "Adjusting Stroller Tracking" go to: [www.burley.com/support/tutorials.cfm](http://www.burley.com/support/tutorials.cfm).

### WARNING

WHEN CONVERTING THIS ATTACHMENT FROM STROLLING TO BIKING, MAKE SURE THAT STROLLER WHEEL IS IN PROPER POSITION BEFORE ATTACHING TRAILER TO YOUR BICYCLE.

### WARNING

THIS PRODUCT WAS DESIGNED FOR USE ON SURFACES THAT ARE MEANT FOR WALKING. DO NOT USE IT ON STAIRS, ESCALATORS OR OTHER UNEVEN SURFACES. NEVER USE IT WITH IN LINE OR ROLLER SKATES. FAILURE TO FOLLOW THESE INSTRUCTIONS CAN CAUSE AN ACCIDENT RESULTING IN SERIOUS INJURY.

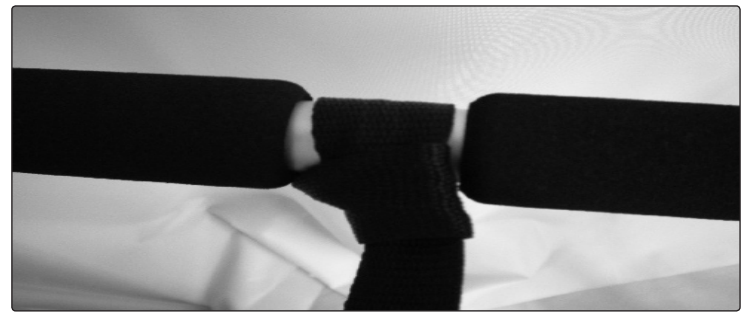

PHOTO 9

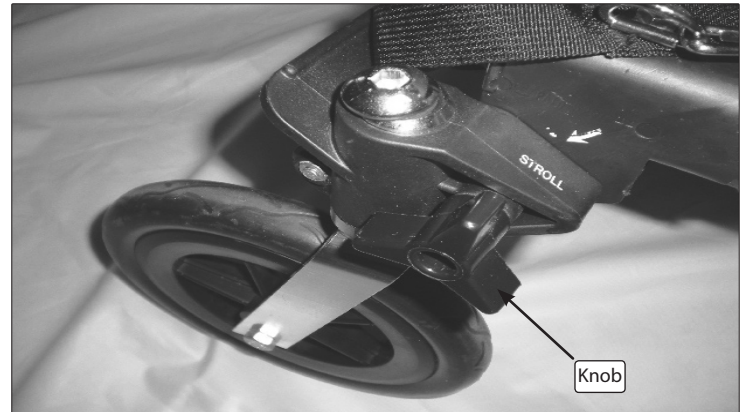

PHOTO 10: Stroller wheel in "Stroll" position

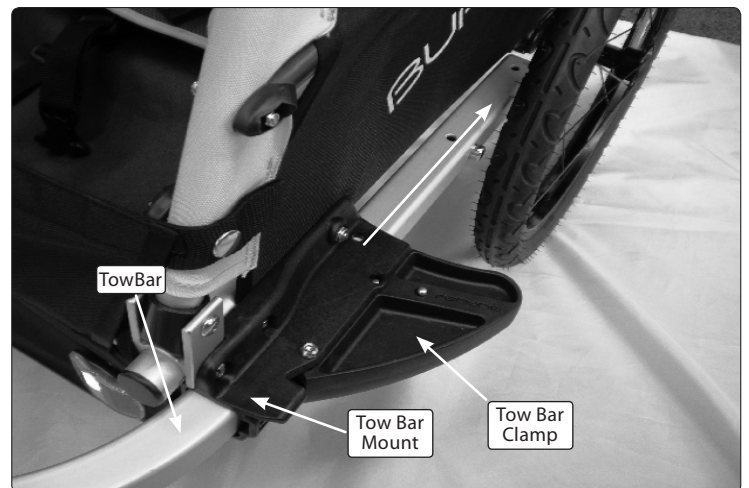

PHOTO 11: Tow bar in "Stroll" position

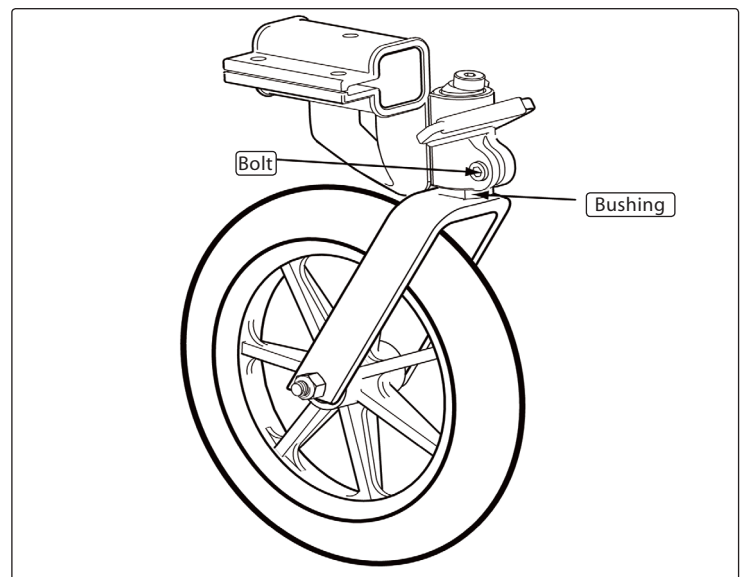

FIGURE 3: To adjust stroller wheel tracking

## Installing Cover

1. At top of trailer frame, fit openings on cover sides around handle bar mounts. Fasten small buckle sections together. Adjust as needed. PHOTO 12
2. On trailer sides, join buckle sections on rear cover corners to buckle sections below side windows.
3. On trailer front, slip D-rings on front cover corners over hooked corners of tow bar mounts.

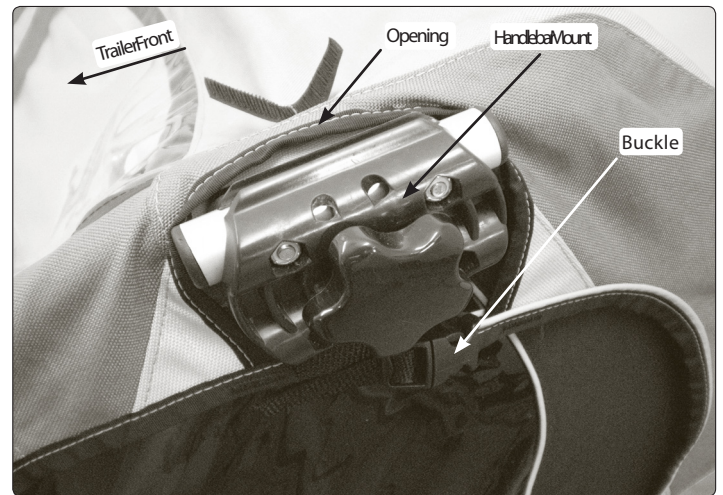

PHOTO 12

## Attaching Handle

Slide handle into lower handle bar receivers and tighten knobs securely. To change height position, flip handle bar over. PHOTO 13

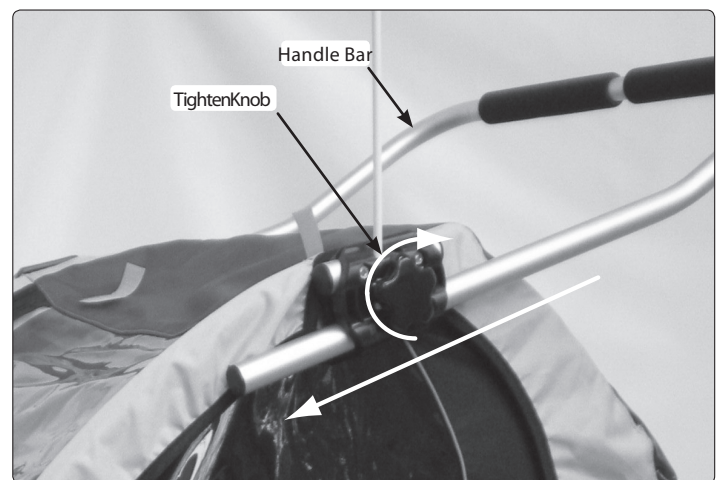

PHOTO 13: Tighten knob clockwise

## Installing Safety Flag

Insert flag pole into hole in top of LEFT handle bar receiver. PHOTO 14

### IMPORTANT

DO NOT USE TRAILER WITHOUT SAFETY FLAG.

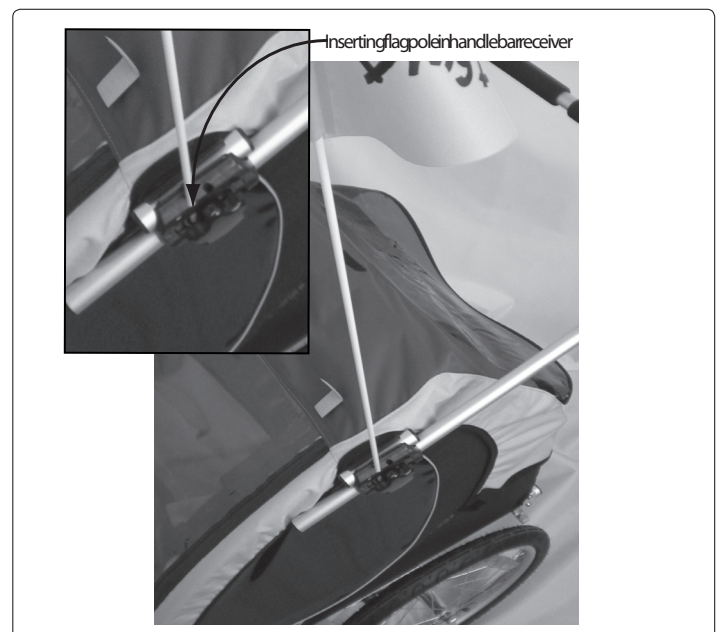

PHOTO 14



## Installing Seat Pads

Match hook and loop fastening strips on trailer seat to back side of seat pad.

## Installing Shoulder Harness and Crotch Strap Pads

Insert shoulder straps through loops on shoulder harness pads, with straps oriented so that FLAT sides of strap buckles face each other. Slide crotch strap through crotch strap pad. PHOTO 15

## Using Seat Harness

One Passenger:

NOTE: In two-passenger trailers, use inner shoulder straps and crotch strap.

1. Place child in center of seat.
2. Snap shoulder straps into Y-buckle, with buckle positioned at child's sternum. Adjust straps so that child cannot move too far forward in seat.
3. Fasten and adjust lap belt snugly. FIGURE 4

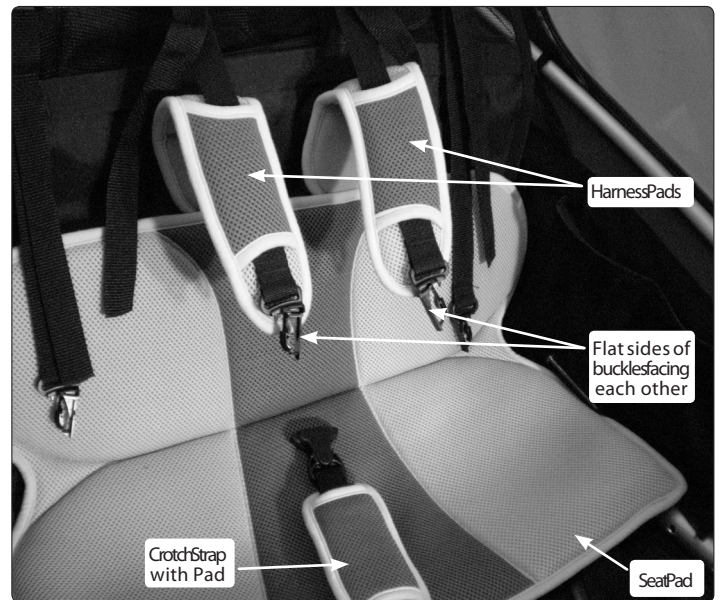

PHOTO 15

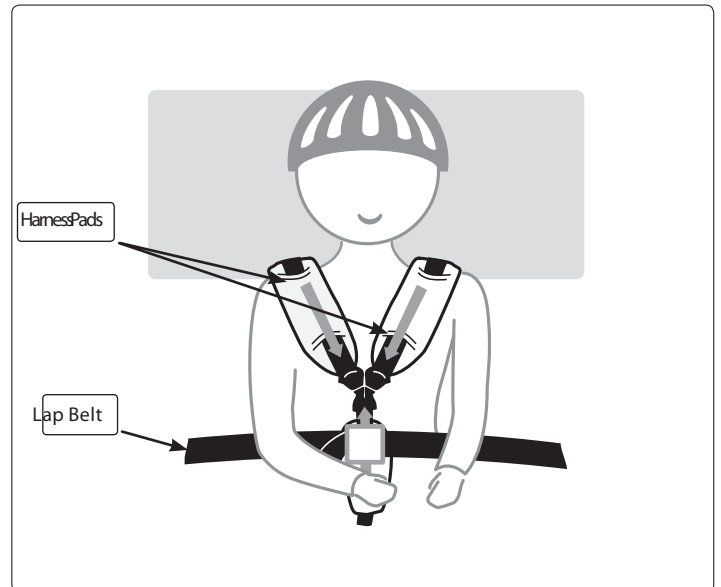

FIGURE 4

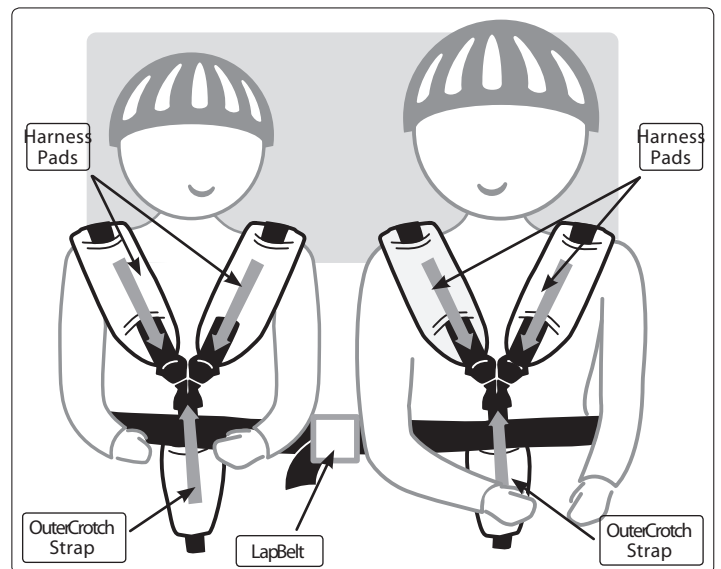

FIGURE 5

## IMPORTANT

SINGLE PASSENGER MUST BE SEATED IN CENTER POSITION.

Two passengers:

NOTE: For two children, use both shoulder harnesses and two outer crotch straps.

1. Seat first child on one side of seat.
2. Snap shoulder straps into Y-buckle, with buckle positioned at child's sternum. Adjust straps so that child cannot move too far forward in seat.
3. Repeat for second child.
4. Fasten and adjust lap belt snugly. To remove children, release lap belt and harness buckles. FIGURE 5

NOTE: For taller children, the seat harness can be adjusted by moving the buckles on the shoulder strap webbing into the helmet pocket area, above the horizontal elastic.

## IMPORTANT

DO NOT SLIDE SHOULDER STRAP ASSEMBLIES ABOVE WEBBING STOPS.

## WARNING

ALWAYS SECURE CHILDREN WITH HARNESS AND LAP BELT BEFORE USE. ONLY USE THIS SEAT IF YOUR CHILD IS CAPABLE OF SITTING UPRIGHT ALONE. FAILURE TO DO SO COULD RESULT IN ACCIDENT AND SERIOUS INJURY OR DEATH.

## Using Seat Recliner

For added comfort when children are sleeping, make the following adjustments to recline seat:

1. Loosen tension on lower horizontal strap on seat back.
2. Loosen tension on helmet pocket straps on upper back of seat. PHOTO 16
3. To return seat to upright position, reverse steps 1 & 2, and make sure upper seat strap is also tightened securely.

## IMPORTANT

UPPER SEAT STRAP SHOULD ALWAYS BE TIGHTENED BEFORE TRAILERING.

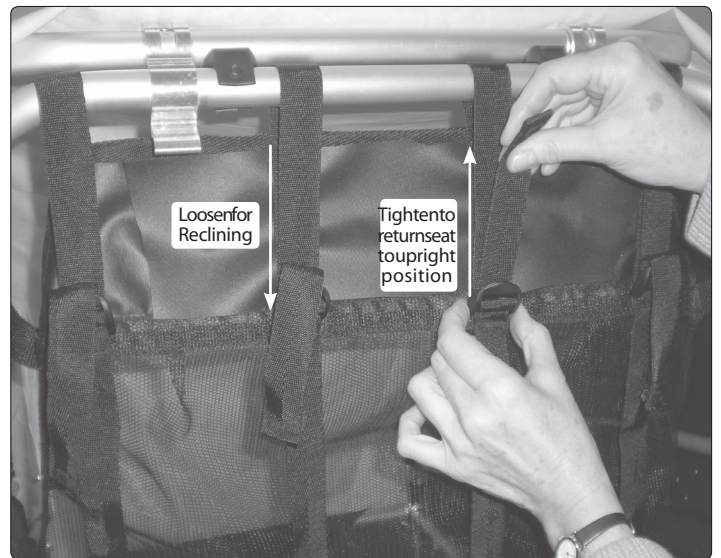

PHOTO 16

## Hitching Trailer to Your Bicycle

NOTE: The Burley Forged Standard Hitch is used for bicycles with either nutted axles FIGURE 6 or quick release assemblies. FIGURES 7 & 8

1. Remove axle nut or rear quick release lever assembly from bike.
2. Match hole on flat side of hitch upper arm to left (non-chain ring side) rear dropout hole, and place hitch flat against the dropout.
3. Loosely reassemble axle nut or quick release assembly through hitch, dropout and wheel. Racks, bags, or fittings should not interfere with hitch.
4. Slide flex connector between hitch side arms, and match holes.
5. Open retaining pin and insert through hitch and flex connector holes from above. Close retaining pin.
6. Tighten axle nut or tighten and close quick release lever, with lever pointing to rear of bike. A properly adjusted quick release lever should leave an imprint on your palm when the lever is rotated to the closed position. Verify that hitch is secure and cannot be rotated by hand.
7. Wrap safety strap twice around inside of chain stay. Fasten hook to D-ring on underside of tow bar end. FIGURE 8
8. To remove trailer from bicycle, unfasten clip from D-ring and remove retaining pin.

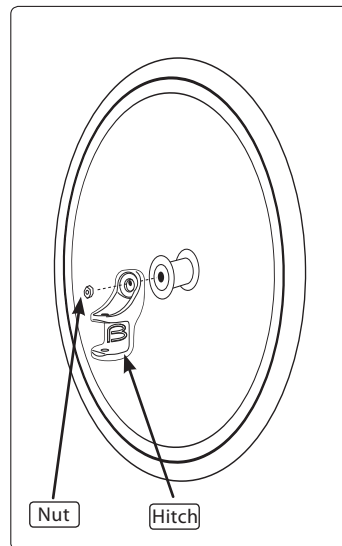

FIGURE 6: Nutted axle assembly

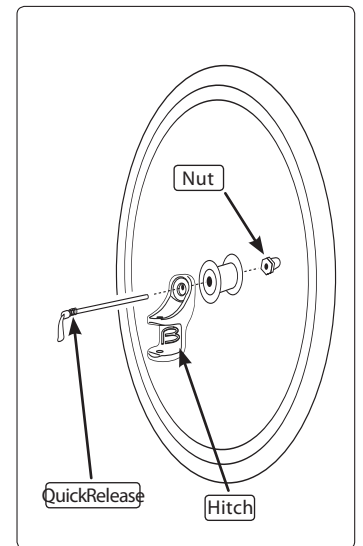

FIGURE 7: Quick release assembly

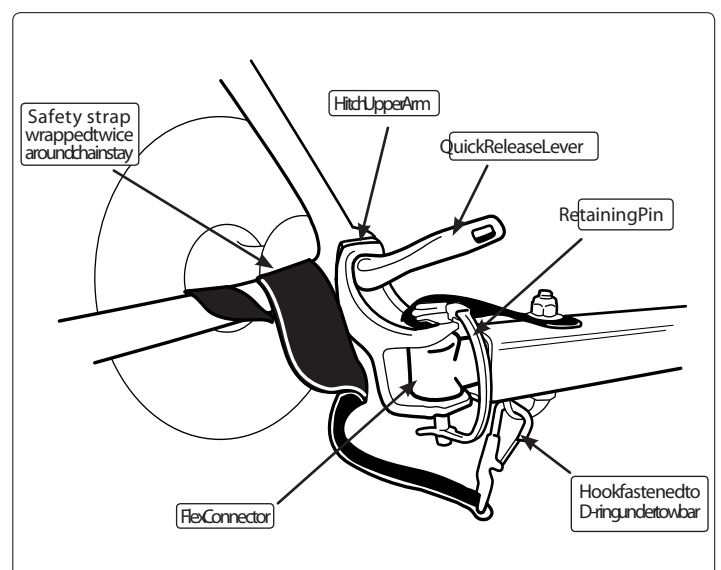

FIGURE 8

## WARNING

QUICKRELEASE LEVER MUST BE IN CLOSED POSITION AND HITCH SAFETY STRAP PROPERLY INSTALLED. NUTTED AXLES MUST BE TIGHTENED SECURELY. HITCH MUST NOT INTERFERE WITH RACKS, BAGS OR FITTINGS. INSPECT HITCH AND TOWBAR FREQUENTLY FOR DAMAGE OR LOOSE FASTENERS. DAMAGED OR IMPROPERLY INSTALLED HITCHES OR INTERFERING PARTS CAN CAUSE ACCIDENTS RESULTING IN SERIOUS INJURY.

## Safety Checklists

### Check Before Each Ride:

- ✓ Wheels tightly and securely attached
- ✓ Tires inflated to recommended pressure on tire side wall
- ✓ Hitch properly secured with safety strap in place
- ✓ Tow bar locked securely in place
- ✓ Maximum load 75 lbs (34 kg) for single trailers and 100 lbs (40 kg by law in Europe) for double trailers
- ✓ Bicycle safety check, especially brakes and tires
- ✓ Helmet for passengers and cyclist
- ✓ Safety flag in place
- ✓ All seat straps properly attached
- ✓ Children properly secured with harnesses and lap belt

### Monthly Checklist:

- ✓ Inspect tow bar, hitch, frame tubing, flex connector and hardware for damage
- ✓ Inspect tires for wear and cracks
- ✓ Inspect wheels for trueness and cracks
- ✓ Inspect wheel bearings for wear
- ✓ Inspect fabric parts for rips, abrasion, or missing or damaged hardware
- ✓ Contact your Authorized Burley Dealer for replacement of any damaged or worn-out parts

## Maintenance and Storage

### Hitch and Tow Bar Maintenance

Store trailer indoors if possible. Do not use or store trailer at temperatures below 32°F (0°C), as hitch flex connector can become brittle and possibly break, causing an accident resulting in serious injury.

### Fabric Care

Hand wash fabric parts with mild soap or detergent and warm water. For heavy soiling, use a nylon bristle brush. Do not use bleach. Line-dry trailer cover. Polyester fabric will eventually fade, especially when exposed to direct sunlight. Wipe dry (to help avoid mildew) and store out of direct sunlight in a dry, well ventilated area, or use a Burley Trailer Storage Cover to protect your trailer. Clean windows with a damp soft cloth. Cover window may crack if trailer is stored below 32°F (0°C). Replace any damaged parts.

## 2009d'LiteST&SoloSTReplacementPartsandDiagram

Diagram #	d'Lite ST Part #	Solo ST Part #	Description	Warranty
1	960041	960041	Forged Standard Hitch	lifetime
2	960009	960009	Safety Flag	1 year
3	950003	950003	Handle Bar Clamp Kit	5 years
4	250033	250042	Handle Assembly w/Tether	lifetime
5	950092	950091	Seat, Harness & Crotch Pad Set (d'Lite ST: 2 pairs of harness & crotch pads; Solo ST: 1 pair) - Blue/Gray	1 year
5	950100	950099	Seat, Harness & Crotch Pad Set (d'Lite ST: 2 pairs of harness & crotch pads; Solo ST: 1 pair) - Red/Gray	1 year
6	950004	950004	Shoulder Safety Strap (Set of 2)	1 year
	250221	250231	Seat (NOT SHOWN)	1 year
	250222	250230	Bag/Side Panels (NOT SHOWN) - Yellow/Black	1 year
	250278	250280	Bag/Side Panels (NOT SHOWN) - Red/Black	1 year
7	950090	950089	Sunshade - Blue	1 year
7	950102	950101	Sunshade - Tan	1 year
8	250224	250232	Cover - Yellow/Blue	1 year
8	250262	250264	Cover - Red/Tan	1 year
9	950075	950075	Tow Bar Receiver Kit, Left (tow bar receiver, bolts, nuts)	5 years
	950108	950108	Tow Bar Receiver Kit, Right (tow bar receiver, bolts, nuts) (NOT SHOWN)	5 years
10	250229	250228	Tow Bar Assembly (tow bar, safety strap, flex connector)	lifetime-tow bar 5 years- flex connector/ safety strap
11	950076	950078	Frame Assembly, Front (tube, frame locks, hinges)	lifetime
12	950009	n/a	Upper Batten (pair)	lifetime
13	950010	n/a	Lower Batten (pair)	lifetime
14	950079	950080	Frame Assembly, Rear (tube, saddles, hinges)	lifetime
15	950081	950083	Lower Frame Set Main frame (L & R), Cross Frame (Front & Rear), Bag Holder	lifetime
16	160029	160031	Wheels (with push button, axle, tire, reflectors) (SOLD INDIVIDUALLY)	5 years
17	950113	950084	Brake Assembly	lifetime
18	250032	250046	External Roll Bar (EURO MODELS)	lifetime
19	950086	950087	Suspension Assembly	5 years
20	950038	950038	Flex Connector for Square Tow Bar w/ Safety Strap	5 years

## Recommended Accessories for the d'Lite ST & Solo ST

- Jogger Kits
- We! Ski Kit
- Storage Cover
- Baby Snuggler
- Handle Bar Console
- Alternative Hitches

Please go to [www.burleygear.com](http://www.burleygear.com) for updated product parts list, diagrams and available accessories

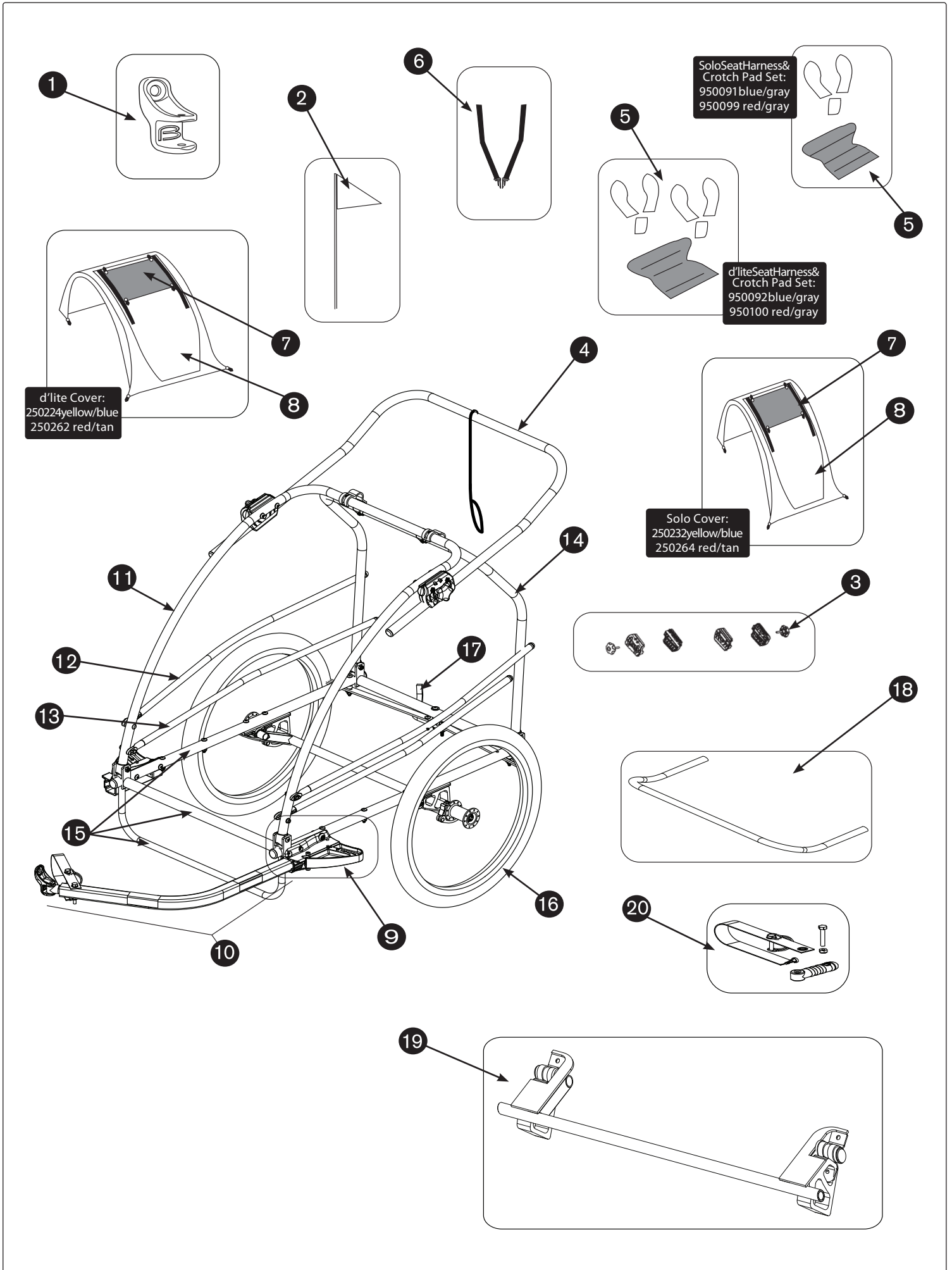

Notes:

Notes:

## Burley Trailer Limited Warranty

Burley trailers are warranted from date of purchase against defects in materials and workmanship under normal use and service. Burley will repair or replace parts it determines to be defective as follows: fabric parts for one year, plastic parts for five years and durable frame parts for the lifetime of the trailer. The Burley trailer owner must present the trailer for repair at place of purchase, with an original sales receipt or similar proof of purchase. This warranty applies only to the original owner and is nontransferable. Burley can not be responsible for failure due to improper assembly, modification of parts or instructions, neglect, abuse, accident, and/or normal wear. The warranty does not cover any trailer used for rental, competition, or commercial use.

Burley neither assumes nor authorizes any person to assume any other liability in connection with this Burley product, and there are no oral agreements or warranties collateral to or affecting this agreement. This warranty gives you specific rights. You may also have other rights which vary by state or country.

# BURLEY®

BURLEY DESIGN

4020 Stewart Rd. Eugene, OR 97402

PH 541.687.1644 800.423.8445 FAX 541.687.0436

burley@burley.com : burley.com

Copyright ©2008 by Burley Design LLC.

"Burley" is a registered trademark of Burley Design LLC

170097 Manual d'lite ST & Solo ST Child Trailer r0 : RTFM : Rev 08.08