

trailericycle

piccolo™

kaZCO™

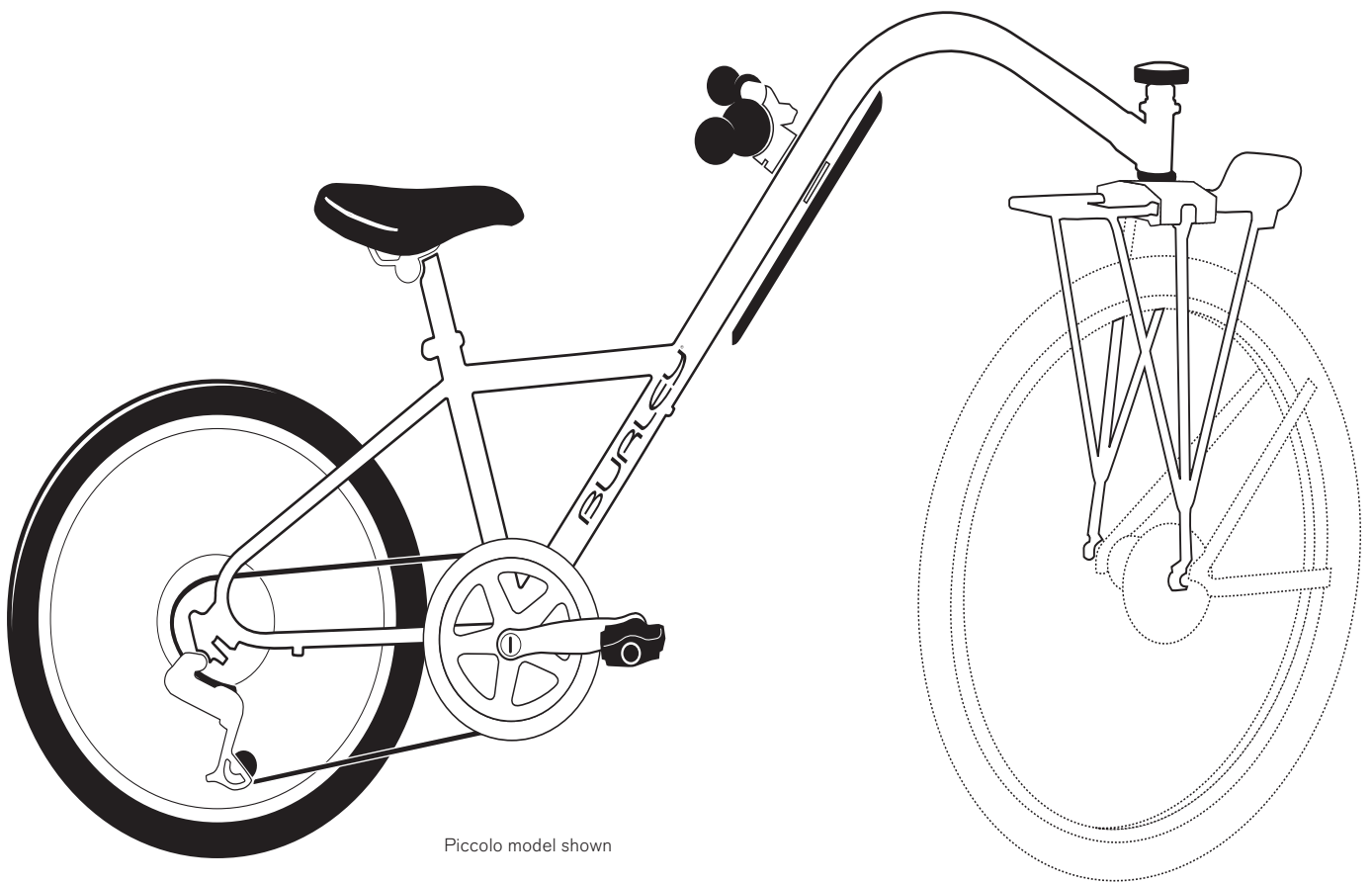

Piccolo model shown

BURLEY
trailercycle

piccolo™

KaZCO™

Trailercycle Owner's Instruction and Safety Manual

Contents

- 3** Introduction
- 3** Parts Inventory
- 3** Safety Guidelines
- 4** Trailercycle Assembly
- 5** Moose Rack™ Installation
- 6** Hitching Trailercycle to Your Bicycle
- 7** Safety Checklist
- 7** Maintenance and Care
- 8** Warranty

Congratulations!

You've just purchased a Burley® trailercycle. Every effort has been made to ensure your purchase is of top quality and proven design, ready to provide you and your family with many years and miles of happy, safe trailercycling.

Please go to www.burley.com or contact us at (541) 687-1644 or burley@burley.com to register your warranty information.

IMPORTANT

IT IS VERY IMPORTANT FOR YOU TO FAMILIARIZE YOURSELF WITH YOUR TRAILERCYCLE BY READING THIS MANUAL BEFORE USE. IF YOU HAVE ANY QUESTIONS, PLEASE CONTACT YOUR AUTHORIZED BURLEY DEALER.

Introduction

IMPORTANT

KEEP THIS MANUAL FOR MAINTENANCE, INSTALLATION, USE AND SAFETY INFORMATION. USE ONLY THE MOOSE RACK FOR TOWING THE PICCOLO OR KAZOO. ALWAYS ENSURE THAT BOTH ADULT AND CHILD WEAR HELMETS.

Before using your Piccolo™ or Kazoo™, you must install the pedals, handlebars, seat, reflector and flag, and then install the Burley Moose Rack™ to your bicycle for towing. Once you properly secure the hitch, adjust the handlebar and seat and perform a safety check, you're ready to ride!

Parts Inventory

Do not proceed with assembly if any parts are missing; contact your Authorized Burley Dealer.

Preassembled Trailercycle Frame
(Serial number located on bottom bracket)

Hitch

Safety Flag

Assembled Handlebar

Seat Post with Saddle

Trailercycle Hardware Bag:

(2) Pedals

(1) Rear Reflector, with Mounting Screw

(1) Reflector Bracket

(2) 5mm Screws

Moose Rack™

Hardware:

(4) M5 Socket Head Screws

(4) Washers

(2) Locknuts

(2) Seat-Stay Band Clamps with Attachment Hardware

Tools required: Phillips screwdriver,
5/8" (16mm) wrench, 4mm & 5mm Allen wrenches

For a complete parts list and product diagram, please go to www.burley.com

Safety Guidelines

Bicycling with a trailercycle is different from bicycling without one. It is essential that you follow all safety guidelines, warnings, and instructions. Contact Burley if these instructions are unclear.

WARNING

BICYCLING WITH A TRAILERCYCLE, AND BICYCLING IN GENERAL, CAN BE HAZARDOUS. FAILURE TO OBSERVE ANY SAFETY GUIDELINES IN THIS MANUAL COULD RESULT IN ACCIDENT, SERIOUS INJURY OR DEATH.

1. Maintain and inspect your bicycle and trailercycle regularly. Follow the instructions in your bicycle owner's manual.
2. The trailercycle is designed for children ages 4-10 with sufficient coordination to pedal and adequate strength to hold on to the handlebars tightly. If your child is physically or mentally impaired, consult your physician as to whether your child can safely ride. Take short rides; stop frequently. Instruct your child to remain alert, and to keep their feet on pedals and hands on handlebars at all times.
3. Both riders must wear helmets.
4. Do not overload the trailercycle. Maximum weight of a child riding your trailercycle is 85 lbs./31.73 kg. Lead rider must weigh at least twice as much as the child. Never allow a child or adolescent to pull your trailercycle. Do not exceed weight limit by attaching a trailer, rack, panniers, or other cargo to the trailercycle.
5. Adjust the seat and handlebar to the correct heights. Ensure that the minimum insertion mark, or at least 2 1/2" (63.5mm), on the seat post remains inside the frame. Don't use a seat post longer than the one supplied, as it could result in an unstable bike.
6. Observe recommended speeds: maximum of 15 mph/24 km/h on smooth, straight roads, and 5 mph/8 km/h or less when turning or on uneven roads.
7. Use only the factory-supplied wheel with the tire inflated to pressure recommended on the tire side wall. Check pressure before each use. Do not use higher-pressure or knobby tires. Be sure axle nuts are properly tightened.
8. Before your passenger gets on and off the trailercycle, come to a complete stop, straddle your bicycle and hold it securely with the brakes locked and both feet on the ground. Never rely on a kickstand to secure the trailercycle. Practice with your child in an uncongested area. Pulling the trailercycle adds length and weight to your load; allow for ample time and distance to stop, start and turn.
9. Do not use off-road, or at night without front and rear lights on both cycles. Avoid sudden swerving, rocks and curbs.

Trailercycle Assembly

IMPORTANT

FOLLOW ALL ASSEMBLY INSTRUCTIONS CLOSELY.

1. Mount pedals (stamped R for right and L for left) to corresponding crank arm and tighten.
2. With screw, mount reflector bracket on left seat stay. Fasten reflector to bracket with mounting screw.
3. Slide flag into bracket.
4. **PICCOLO ONLY:** Fasten splashguard to stem with two 6 mm bolts supplied with fender.
5. Insert seat post into seat tube. Tighten quick release lever. Ensure that the minimum insertion mark, or at least 2 1/2" (63.5mm) on the seat post remains inside the frame.
6. To install handlebar, remove face plate, place handlebar into clamp and replace face plate, clamping handlebar to stem. Center handlebar in stem. Tighten bolts.
7. Insert trailercycle tongue into hitch spindle and tighten both nuts securely. **PHOTOS 2A AND 2B**

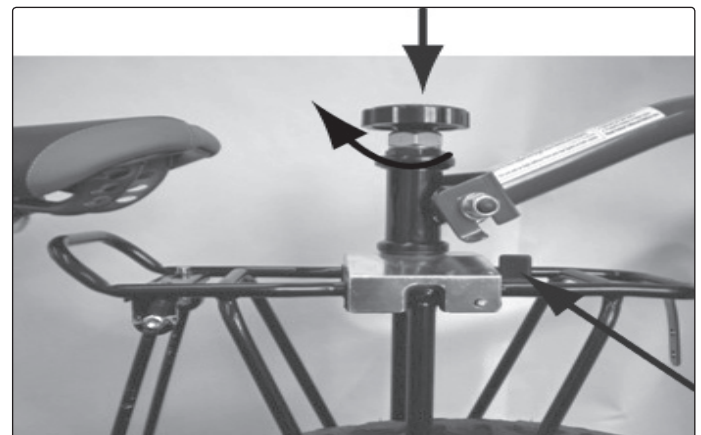
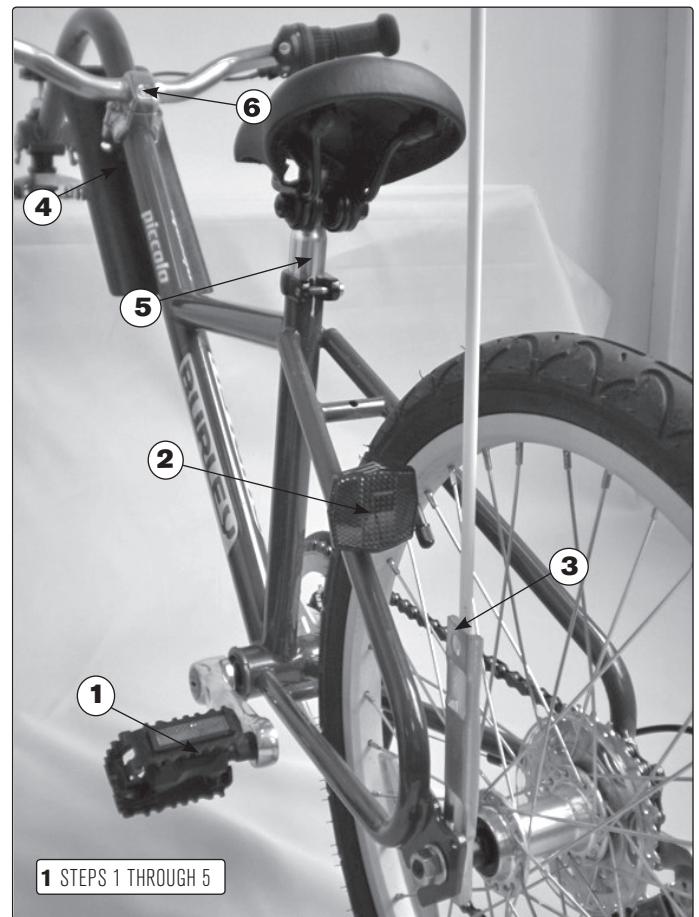

2A Before tongue insertion



2B After nuts tightened

Moose Rack Installation

1. Using washers and socket head screws, attach bottom of rack to holes in bicycle dropouts.
2. Position top of rack parallel to the ground. Check distance from stay mounting hole on Moose Rack to the bicycle's seat stays. **FIGURE A**

WARNING

RACK MUST BE LEVEL. WHEN PULLING A TRAILERCYCLE, A NON-LEVEL RACK CAN ADVERSELY AFFECT BICYCLE HANDLING, RESULTING IN AN ACCIDENT OR SERIOUS INJURY.

3. Adjust rack stays to fit. **PHOTO 3**
4. Temporarily attach rack stays to rack and bicycle with washers and socket head screws (**PHOTO 4**), or use band clamps to attach rack stays to seat stays (**PHOTO 5**).
5. If stays protrude above top of rack, excess length can be trimmed with a hacksaw. Mark stays, then remove stays to cut.
6. Reinstall stays and tighten all nuts.
Recommended torque:
M6 Nuts: 6-8 N-m (Newton-meter)
M5 Screws: 4-5 N-m

IMPORTANT

HARDWARE FOR ATTACHMENT TO BIKES WITH THREADED EYELETS IN REAR DROPOUT IS PROVIDED. CONTACT YOUR AUTHORIZED BURLEY DEALER BEFORE ATTEMPTING TO MOUNT MOOSE RACK ON A BIKE WITHOUT THREADED EYELETS IN THE REAR DROPOUT.

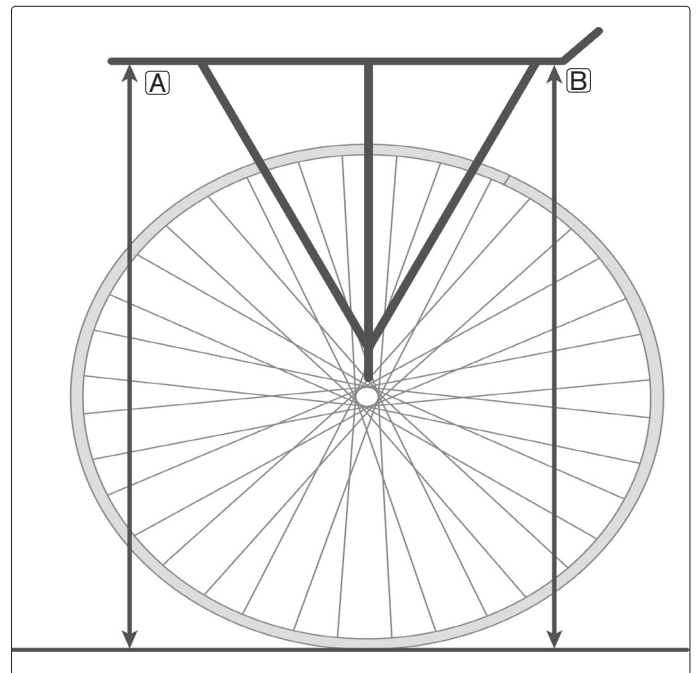

FIGURE A: The difference between heights A & B must be less than 3/4" (19.05 mm)



3 Stays adjust as indicated by arrows



4



5

Hitching the Trailercycle to Your Bicycle

1. Slide lever to retract safety pins. Safety pin lever and safety pins must slide freely. **PHOTO 6**
2. Set hitch plate on rack and release lever to engage pins.
3. Push knob down and tighten fully. **PHOTO 7**

IMPORTANT

KNOB MUST BE TIGHTENED AND SAFETY PINS ENGAGED BEFORE USE. DO NOT USE YOUR TRAILERCYCLE IF YOU ARE UNABLE TO SECURELY TIGHTEN KNOB OR GET FULL ENGAGEMENT OF THE SAFETY PINS.

⚠ WARNING

TRAILERCYCLE MUST BE ATTACHED TO BURLEY MOOSE RACK, USING ONLY BURLEY HARDWARE. RACK OR HARDWARE FROM OTHER SUPPLIERS MAY BREAK OR DETACH, RESULTING IN ACCIDENT AND SERIOUS INJURY.

IMPORTANT

BEFORE USING YOUR TRAILERCYCLE, BE SURE HANDLEBARS, STEM AND SEAT ARE PROPERLY ADJUSTED SO YOUR CHILD IS COMFORTABLE.

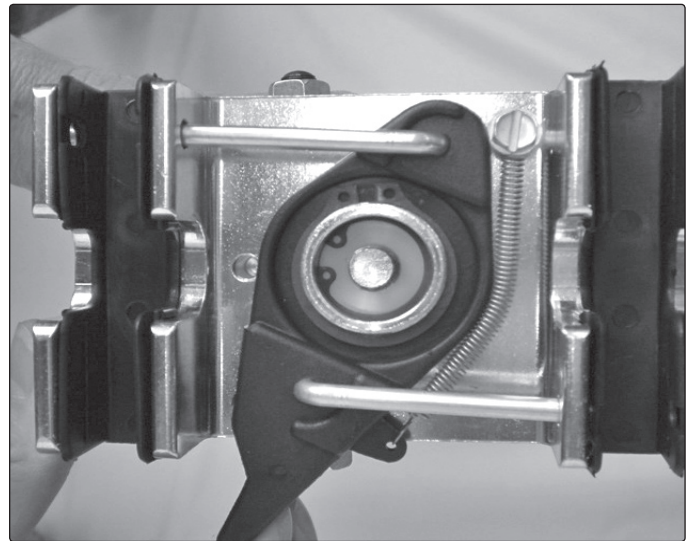

6 Bottom of hitch with pins retracted



7 Trailercycle hitched to bike. Push down and turn to tighten as indicated by arrows.

Safety Checklist

Note: Adult lead cyclist must weigh at least twice as much as trailing child

Before Each Ride:

- Maximum child weight 85 lbs./31.73 kg.
- Hitch tightly attached
- Moose Rack securely attached to bicycle
- Handlebars, seat and wheel secured
- Trailercycle tire inflated to recommended pressure
- Helmets for both riders
- Powerful brakes on bicycle
- Bicycle safety check, especially brakes and tires
- Safety flag and reflectors in place

Trailercycle Maintenance and Care

IMPORTANT

FAILURE TO MAINTAIN YOUR BURLEY TRAILERCYCLE PROPERLY CAN RESULT IN ACCIDENT AND SERIOUS INJURY.

Hitch Maintenance

- Inspect headset, hitch-spindle, safety pins, and hitch knob assemblies before each ride to ensure that all are tightly assembled, and that safety pin lever and safety pins can slide freely. **FIGURE B**
- Maintain hitch-spindle assembly like a bicycle hub.
- Tighten hitch-spindle nuts.

Every-Other-Month Maintenance

- Inspect hitch for damage and loose fasteners. Safety pin lever and safety pins must slide freely.
- Clean and lubricate hitch bolt and threads on rack; keep oil clear of bike's brake and rim surfaces.
- Clean and lubricate chain.
- Inspect hitch-spindle and headset for smooth operation; tighten all nuts.
- Check and tighten all mounting screws and hardware on both trailercycle and Moose Rack, especially handlebar stem bolts.
- Inspect frame tubing and hardware for cracks, damage, or loose parts.
- Inspect tire for cracks or worn spots.
- Repair or replace any damaged or worn-out parts.

Annual Maintenance

Note: If you are riding in rain, perform this maintenance every six months.

- Clean and lubricate pivot points on derailleur; wipe excess oil to prevent dirt buildup.
- Inspect derailleur cable for fraying and replace as necessary.
- Adjust gears as necessary.
- Verify that seat is properly positioned and tightened securely.
- Tighten all nuts and screws on trailercycle and Moose Rack.
- Check wheel for trueness; inspect for cracks at spoke hole or sidewall. Retrue or replace if necessary.
- Verify that bottom bracket spins smoothly and doesn't exhibit any play; tighten fixing bolts for crank arms.
- Disassemble and repack bearings in headset, hitch-spindle, hub, and pedals.
- Inspect chain, chainring, and rear cogs; replace if worn.
- Repair or replace any damaged or worn-out parts.

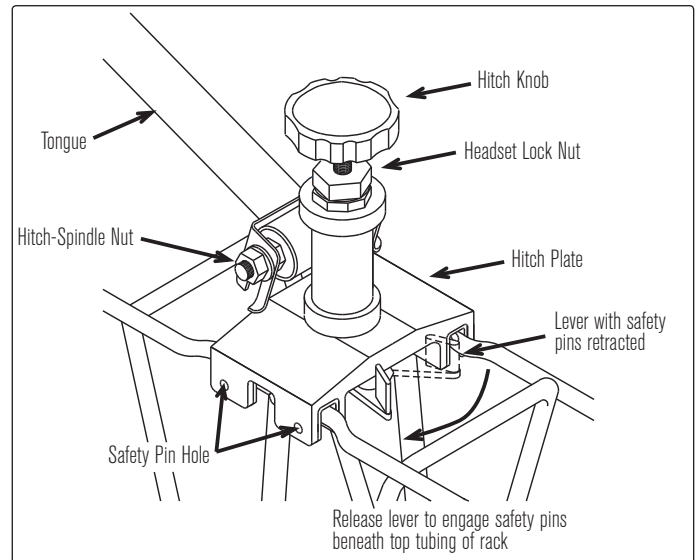

FIGURE B

Burley Trailercycle Limited Warranty

Burley trailercycles are warranted against defects in materials and workmanship under normal use and service. Burley will repair or replace parts it determines to be defective as follows: original equipment parts for a period of 180 days from date of purchase; and rack and hitch for five years from date of purchase. Frames have a limited lifetime warranty. The Burley trailercycle owner must present the trailercycle for repair within the warranty period at place of purchase, with an original sales receipt or similar proof of purchase. This warranty applies only to the original owner and is nontransferable. Burley can not be responsible for failure due to improper assembly, modification of parts or instructions, neglect, abuse, accident, and/or normal wear. The warranty does not cover any trailer used for rental, competition, or commercial use, or the cost of repair or replacement for any bicycle or equipment other than the Burley trailercycle and rack.

Burley neither assumes nor authorizes any person to assume any other liability in connection with this Burley product, and there are no oral agreements or warranties collateral to or affecting this agreement. This warranty gives you specific legal rights. You may also have other rights which vary from state or country.

BURLEY[®]

BURLEY DESIGN, LLC

4020 Stewart Rd. Eugene, OR 97402

PH 541.687.1644 800.423.8445 FAX 541.687.0436

burley@burley.com • www.burley.com

Copyright © 2007 by Burley Design LLC

"Burley" is a registered trademark of Burley Design LLC

"Piccolo," "Kazoo," and "Moose Rack" are trademarks of Burley Design LLC

Rev 09/08 170047 manual trailercycles 09 piccolo kazoo r1