

EXPLOSION-PROOF LED TLX7240 SERIES INSTALLATION, OPERATION AND MAINTENANCE DATA SHEET

IMPORTANT - Before installing, check the carton label and fixture nameplate to be sure you have the correct type of fixture. Read all instructions before proceeding.

WARNING - Deactivate circuit before beginning installation.

NOTE: All installations must comply with applicable local and or National Electrical Code.

INSTALLATION:

1. Using the component drawing shown here, remove the splice box from the fixture (if attached).
2. Refer to the splice box mount instruction sheet K1087 included with the splice box. Install the pendant mount splice box to the conduit and secure with locking set screw. Install the ceiling mount using four (4) external mounting screws.

NOTE: Fixture splice box must be grounded.

3. Remove the terminal block from the splice box by loosening the two (2) mounting screws.
4. Connect the ground wire to the green screw inside the base of the splice box.
5. Connect the supply lines to the terminal block.
6. Reinstall the terminal block in the splice box, and securely tighten it in place.
7. Thread the fixture into the splice box and secure with the set screw. Be sure that the mating threads are clean and adequately lubricated.
8. Check the tightness of all set screws and all threaded joints. Turn on the supplying circuit to test the fixture.

Save the installation instructions for maintenance personnel.

OPERATIONAL DATA

Operate this fixture at its rated voltage. See fixture nameplate for this data.

MAINTENANCE DATA

This fixture requires no internal adjustment. This fixture has no internal replacement parts.

To maintain maximum light output from this fixture, it should be cleaned periodically per the following suggestions.

The aluminum exterior of the fixture should be cleaned only with a mild soap or cleaner, and should be rinsed with water immediately. Alkaline or acidic cleaners should never be used on aluminum.

The glass globe may be cleaned with any non-abrasive cleaner. The globe should be regularly inspected for scratches and chips.

These periodic cleaning procedures are important in preventing the accumulation of dust and dirt which will impair the light output of the fixture.

TOMAR

EXPLOSION-PROOF LED TLX7240 SERIES

INSTALLATION, OPERATION AND MAINTENANCE DATA SHEET

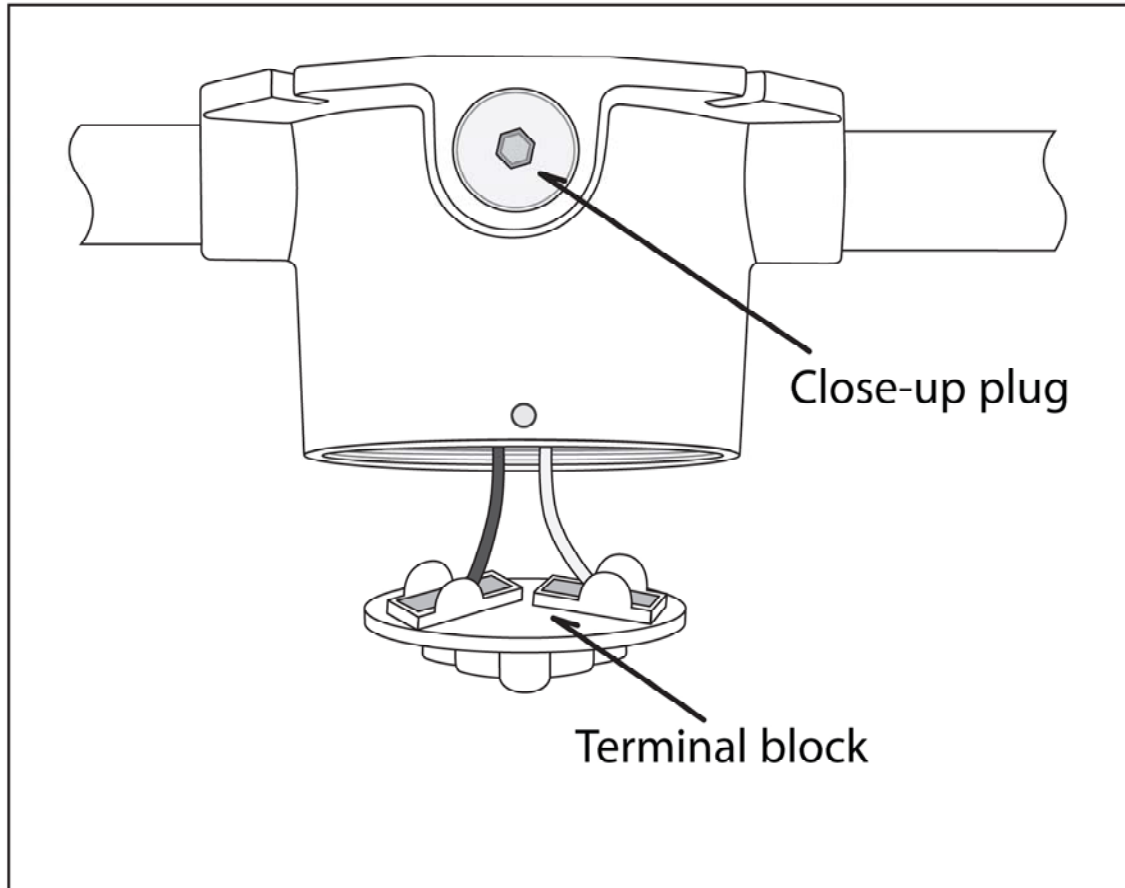

TOMAR Electronics, Inc.

2100 West Obispo Gilbert, Arizona 85233 USA

(480) 497-4400 (800) 338-3133

FAX (480) 497-4416 (800) 688-6627

E-mail: sales@tomar.com

www.tomar.com