

# FREEDOM

## INDUSTRIAL HYDRAULICS

---

### 10,000 P.S.I. AIR/HYDRAULIC FOOT PUMP SETUP • OPERATING • MAINTENANCE INSTRUCTIONS

---

#### **IMPORTANT: READ THESE INSTRUCTIONS BEFORE OPERATING**

**BEFORE USING THIS DEVICE, READ THIS MANUAL COMPLETELY AND THOROUGHLY, UNDERSTAND ITS OPERATING PROCEDURES, SAFETY WARNINGS AND MAINTENANCE REQUIREMENTS. FAILURE TO DO SO COULD CAUSE ACCIDENTS RESULTING IN SERIOUS OR FATAL PERSONAL INJURY AND/OR PROPERTY DAMAGE.**

The use of air/hydraulic foot pumps is subject to certain hazards that cannot be prevented by mechanical means, but only by the exercise of intelligence, care, and common sense. It is therefore essential to have owners and personnel involved in the use and operation of equipment who are careful, competent, trained, and qualified in the safe operation of the equipment and its proper use. Hazards such as pressurized hydraulic fluid bursting from hoses or fittings can happen resulting in loss of load, uncontrolled lowering or dropping of load if instructions are not followed. Failure to avoid

hazards could cause accidents resulting in serious or fatal personal injury and/or property damage.

It is the responsibility of the owner to make sure all personnel read this manual prior to using this device. It is also the responsibility of the device owner to keep these instructions intact and in a convenient location for all to see and read. If these instructions are lost or not legible, contact FREEDOM for a free replacement. If the operator is not fluent in English, the product and safety instructions shall be read to and discussed with the operator in the operator's native language by the purchaser/owner or his designee, making sure that the operator comprehends its contents.

#### **WARRANTY**

This product is covered by a Limited Lifetime Warranty. For details see the back cover of FREEDOM's product catalog.

---

#### **WARNING**

- Do not use hoses in systems exceeding 10,000 psi (700 bar).
  - The system operating pressure must not exceed the pressure rating of the lowest rated component in the system.
  - Avoid sharp bends and kinks when routing hydraulic hoses.
  - Do not drop heavy objects on hose.
  - Do not use the hydraulic hose to carry a hydraulic component.
  - Keep hydraulic equipment away from flames and heat.
  - Keep hose away from sharp objects and eliminate abrasion.
  - Inspect the system before each use. Replace questionable components immediately.
  - Use only compatible fluids.
  - Make sure quick disconnect fittings are correctly and completely fastened together. Quick disconnect couplers should be hand tightened only. Never use tools.
  - Never attempt to disconnect couplers while under system pressure.
  - Be sure pressure system and setup are stable before using.
- 

#### **BEFORE OPERATING**

1. Remove the large allen socket pipe plug in the hydraulic connections of the foot pump manifold. Remove any remnants of teflon tape that may still be in the threads of the hydraulic connections.
2. Determine if your system will require a poppit valve to restrict the return flow of oil back to the pump's reservoir. Consult the "OPERATING INSTRUCTIONS" portion of this manual to determine if your system requires a poppit valve. If your system does require a poppit valve, install the tapered end of the poppit valve into the threaded hole at the end of the elbow fitting. Make sure the poppit valve is inserted all the way until it bottoms out on the seat at the bottom of the threaded hole.
3. Make sure the hose fitting threads are not crossthreaded. Use at least 1-1/2 wraps of teflon tape (or suitable sealant) on the threads. Make sure the first complete thread is free from tape or sealant so they do not enter and contaminate the hydraulic system.
4. If tubing is used instead of hose, make sure the tubing is supported. Unsupported tubing can lead to premature fitting failure. Always hard mount valves and gages and never allow tubing to support them. Place tube supports 4 to 7 inches behind the fitting.
5. The air quick disconnect configuration of your choice can be installed in the threaded hole underneath the foot pedal labeled "PUMP". Prepare the threaded hole in the pump and air quick disconnect threads in the same manner as described in steps 1 and 3 of this section titled "BEFORE OPERATING".
6. The reservoir fill cap comes installed on your pump. Remove this cap and replace with the supplied dipstick/vent plug before use. The pump will not work to its maximum efficiency unless this air vent is opened. Reinstall the reservoir cap when not using or transporting the pump.
7. An in-line filter/regulator/lubricator should be installed close to pump. Add a few drops of SAE 30 oil to the air intake weekly if no lubricator is used or when pump will be idle for a long time.

## SINGLE-ACTING AIR PUMP OPERATING INSTRUCTIONS

1. Determine the layout of your hydraulic system based on the work to be performed. If the pump is used with a ram in collision repair work or in a press as a power source, there will most likely not be a need to consider installing either of the two poppet valves included with the pump. If the pump is used with a ram that activates a shop crane boom or any other mechanical leverage that would increase the rate of descent of such leverage when the pump pedal is released, a poppet valve should be installed in the pump in accordance with the instructions given in step 2 of the "BEFORE OPERATING" section of this manual. The two poppet valves look the same but the small orifice at the tapered end of the valves are two different sizes. Obviously the poppet valve with the smallest orifice restricts the return of hydraulic fluid back to the pump's reservoir more. If you cannot determine which poppet valve to use, install the valve with the smallest orifice first. If the smallest orifice restricts the return of fluid too much, use the valve with the larger orifice. **IMPORTANT:** Before using the pump under load, become familiar with the operation of the foot pump. Depressing the foot pedal end marked "PUMP" activates the ram. To activate the ram a small distance it is necessary to use incremental taps of your foot on the foot pedal until the ram reaches the desired distance. Retracting the ram is accomplished by depressing the foot pedal

end marked "RELEASE". The pump is equipped with a two speed release mechanism. Gently depressing the foot pedal end marked "RELEASE" retracts the ram slower than if you depress the pedal all the way down. If you want to retract the ram slower than the low speed release, use gentle incremental taps of your foot on the "RELEASE" pedal.

2. Be sure hoses do not have cracks, kinks, cuts or other damage which might cause the hoses to leak. If hoses include spring guards, make sure the springs protect the crimped areas of each end of the hose.
3. Hose should not be twisted or bent too sharply. The bend radius should not be less than nine times the outside diameter of the hose. Always use as few bends as possible.
4. Make sure all hose ends, couplers, or union ends are clean and threads are in good condition.
5. Make sure all hose connections between pump and rams are tight and leak free. Do not over-tighten connections. Excessive tightening may cause premature thread or fitting failure.
6. When using quick disconnect fittings, make sure fittings are correctly and completely fastened together.

## DOUBLE-ACTING AIR PUMP OPERATING INSTRUCTIONS

1. Determine the layout of your hydraulic system based on the work to be performed. If the pump is used with a ram in collision repair work or in a press as a power source, there will most likely not be a need to consider installing either of the two poppet valves included with the pump. If the pump is used with a ram that activates a shop crane boom or any other mechanical leverage that would increase the rate of descent of such leverage when the pump pedal is released, a poppet valve should be installed in the pump in accordance with the instructions given in step 2 of the "BEFORE OPERATING" section of this manual. The two poppet valves look the same but the small orifice at the tapered end of the valves are two different sizes. Obviously the poppet valve with the smallest orifice restricts the return of hydraulic fluid back to the pump's reservoir more. If you cannot determine which poppet valve to use, install the valve with the smallest orifice first. If the smallest orifice restricts

the return of fluid too much, use the valve with the larger orifice. **IMPORTANT:** Before using the pump under load, become familiar with the operation of the foot pump. Depressing the foot pedal end marked "PUMP" activates the ram. To activate the ram a small distance it is necessary to use incremental taps of your foot on the foot pedal until the ram reaches the desired distance. Retracting the ram is accomplished by moving the directional valve to the retract position and depressing the foot pedal end marked "PUMP" to activate the ram.

2. Placing the directional valve in the appropriate position will determine which direction your ram will move. There are 3 positions, explained in the diagram below.
3. Continue to Step 2 of Single-Acting instructions above.

## FLOWPATH OF THE VALVE POSITIONS AND OPERATIONS

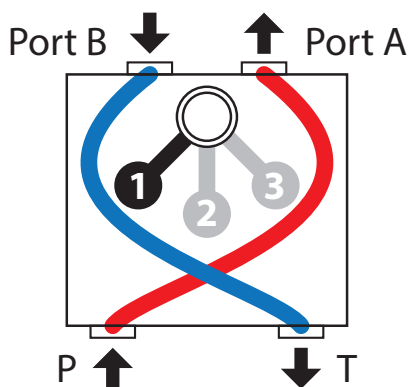

POSITION 1

Oil flows to port A, and will build pressure according to load, while port B will allow oil to flow back to the tank.

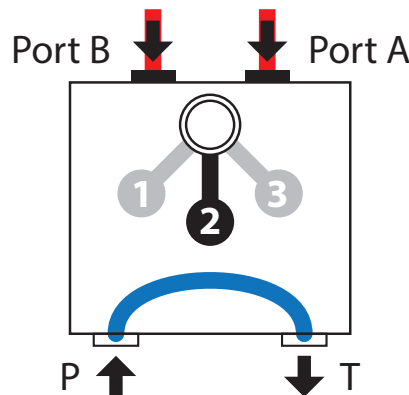

POSITION 2

This is the "Neutral" position. The pump will cycle oil back to the tank, while ports A and B will be closed and holding position.

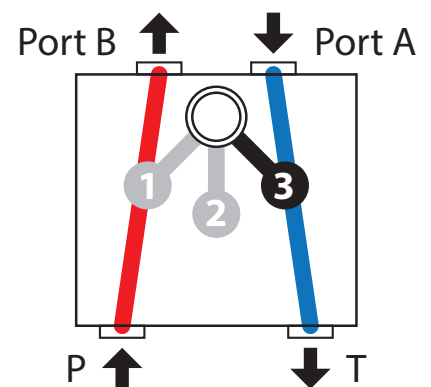

POSITION 3

Oil flows to port B, and will build pressure according to load, while port A will allow oil to flow back to the tank.

## PREVENTATIVE MAINTENANCE

1. Keep components clean at all times. Use every precaution to guard against dirt entering the system.
  2. Cover couplers with dust caps when not connected to the system. All coupler threads must be clean and lubricated regularly.
  3. Change fluid in system components as recommended by the manufacturer.
  4. Leave hydraulic hoses in the carton until needed.
  5. Store hoses away from direct sunlight, moisture, or temperatures above 75°F (24°C) or below 50°F (10°C).
  6. Do not stack hoses. The weight of the pile may flatten hoses on the bottom. Hang the hoses.
- 

## REPAIR SERVICE

If your FREEDOM product requires service or repair, contact the FREEDOM Customer Service Department for the location of the nearest FREEDOM Authorized Service Center.

Freedom Industrial Hydraulics  
226 NW Platte Valley Dr.  
Riverside, MO 64150  
(816) 541-3243 • Fax: (816) 541-3246  
[www.freedomhydraulics.com](http://www.freedomhydraulics.com)

It will be necessary to provide the FREEDOM Authorized Service Center with a copy of the bill of sale if requesting warranty repair. If the authorized service center determines your product is eligible for warranty repair, the repair will be made at no charge and returned freight prepaid. The cost of non-warrantable service, repair, and return freight is the customer's responsibility.