



Technical Data Sheet-PB

PB-7 Adjustable from 365 to 480 mm

COMPONENTS

The PB-7 is composed of 3 pieces
(1 PB-4 top + 1 coupler PB-C2 + 1 PB-4 base)

CHARACTERISTICS

Top: \varnothing 170 mm, 227 cm²

Base: \varnothing 197 mm, 305 cm²

Weight: 1,17 kg

Height adjustable from 365 to 480 mm

With addition of U-PH5 slope corrector, adjustable in height from 379 to 494 mm and slope from 0 to 5%

MATERIAL

Copolymer polypropylene (CPP) made from 95% recycled plastics

Designed and manufactured in Europe

Use of recycled materials exclusively of EU origin

Resistant to weathering, sea salts, algae and a wide range of chemicals

Temperature range: -30 C° to +80 C°

PACKAGING

Packaging PB-4-Base

Pieces per carton: 24 pcs

Carton weight: 9,82 kg

Carton dimension: 610 x 410 x 455 mm

Cartons per pallet: 25 pcs

Pieces per pallet: 600 pcs

Pallet dimensions: 100 x 120 x 220 cm

Packaging PB-C2

Pieces per carton: 24 pcs

Carton weight: 13,3 kg

Carton dimension: 600 x 420 x 610 mm

Cartons per pallet: 15 pcs

Pieces per pallet: 360 pcs

Pallet dimensions: 100 x 120 x 220 cm

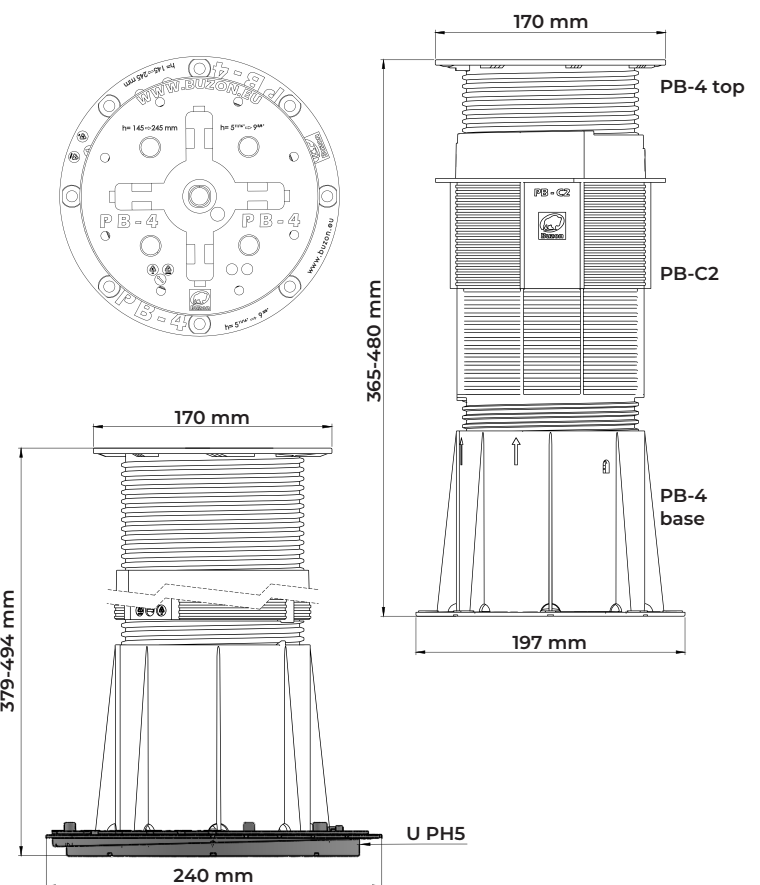

Packaging PB-4-Top

Pieces per carton: 24 pcs

Carton weight: 9,05 kg

Carton dimension: 610 x 410 x 455 mm

Cartons per pallet: 25 pcs

Pieces per pallet: 600 pcs

Pallet dimensions: 100 x 120 x 220 cm

APPLICATIONS

Buzon pedestals can be used for a wide range of outdoor applications, such as terraces, pool decks and water features, in landscape areas and on rooftops... Finishing materials can be freely specified by the designer. Accessories are available for applications with various outdoor finishes, such as granite stone pavers, composite / timber decking, ceramic tiles and fibreglass or metal grating panels. Buzon pedestals can be installed on a wide range of solid and stable substrates, such as concrete slabs, cement screeds, waterproof membranes, insulation panels.

Batten Holder



Aluminium Rail Holder



Spacer Tabs



Thickness:
2, 3 and 4,5mm

Shims



U-E10 (T- 1mm)
U-E20 (T- 2mm)

COMPRESSION TEST*

Performed on the full (1/1), half (1/2) and quarter (1/4) surface of the head (1kN= 1kg/F= 224,8 lbF)

Position	Height (mm)	Breaking load (kN)	Breaking load (lbF)
1/1	480	13,36 (1 336 kg)	3 006
1/2 **	480	10,67 (1 067 kg)	2 401
1/4 **	480	6,53 (653 kg)	1 470

* Tests carried out by SIRRIS at 23°/50%

** Maximum load per pedestal : refer to value 1/1

** Safety recommendation for use of Buzon Pedestals System :

1. Areas reserved for pedestrian access: divide the load indicated in the table by 2 with an additional safety factor of -15%.
2. Areas reserved for industrial and technical applications: divide the load indicated in the table by 4 with an additional safety factor of -15%.

SAFETY INSTRUCTIONS

Buzon pedestals are designed to support external raised floors for pedestrian traffic only and are not designed to support or be subjected to moving and/or vibrating machinery & equipment, including maintenance, cleaning vehicles, automobiles and other similar equipment.



Buzon has a policy of continuous improvement and reserves the right to modify, revise or change the above specifications without notice. This brochure is for descriptive purpose only and is based on the product as on the date of publication of this information.

BPI21 © Copyright Buzon Pedestal International SA Buzon DPH® is a registered trade mark of Buzon Pedestal International SA.