

# Installation instructions SZ118

## Anchor tube to be embedded in concrete for type SCHATTELLO

The following instructions include all information necessary for the installation and operation of this anchor tube. To avoid any misunderstanding we advise you to read these instructions carefully before use and then keep them for later reference.



**Caution**

**Non- observation of installation instructions can result in personal injuries or damage to property.**

Please note that if these instructions are not observed, the manufacturer cannot accept any liability or guarantee.

- Always follow the safety regulations.
- Should you not understand any part of these installation instructions, please contact your MAY dealer.

### Diagram showing installation components

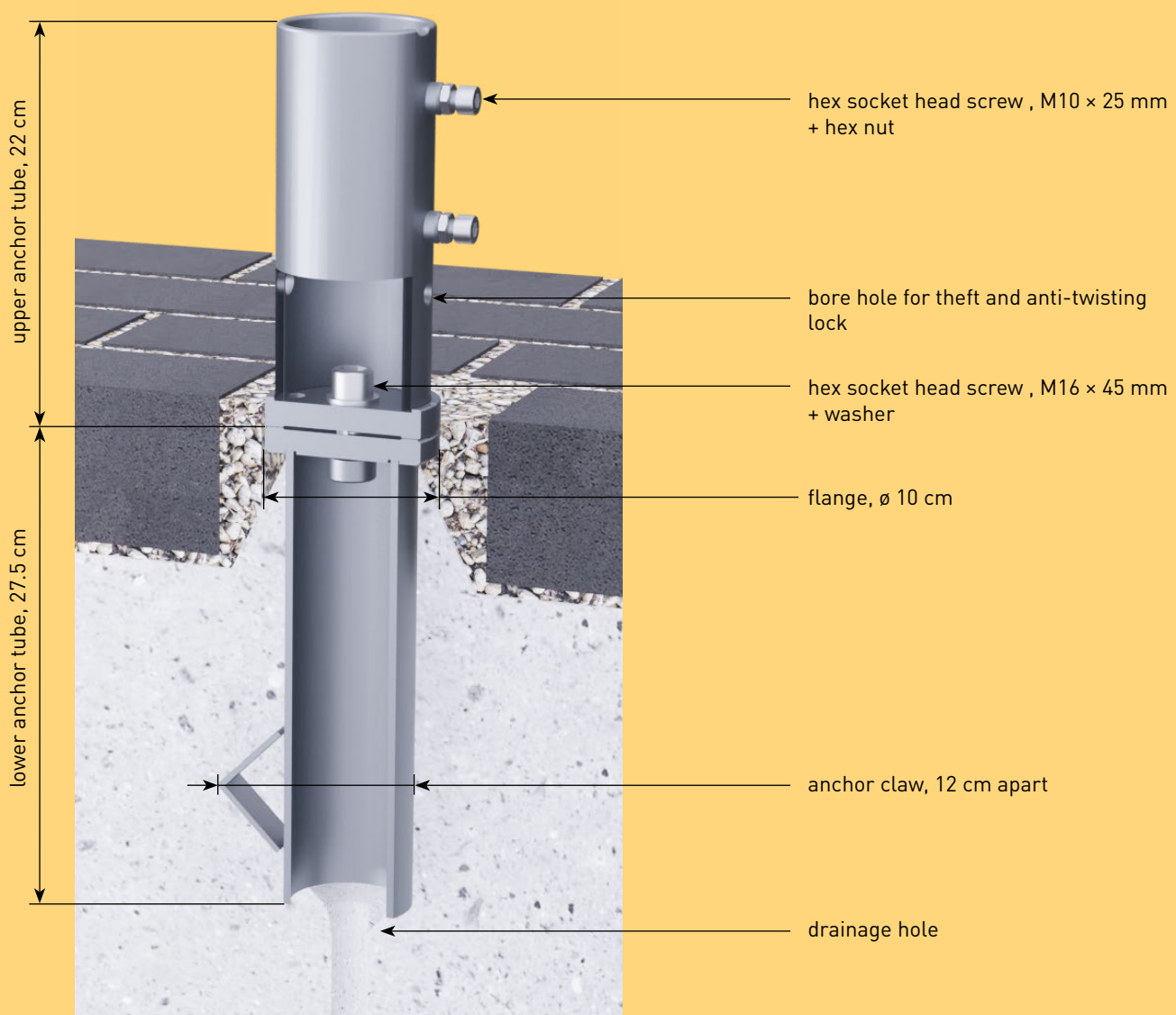

## Determining the location for the foundation

1. Allow sufficient space between parasols or between the wall of the house and the parasol.



Caution

### Parasols that are located too close together wear sooner.

Parasols may sway slightly. If there is not enough space between them, they may touch and abrade or scour the canopy fabric at the spoke ends.

- Make sure that there is a clearance of 15-20 cm between the parasols (or between the parasol and the wall of the house).

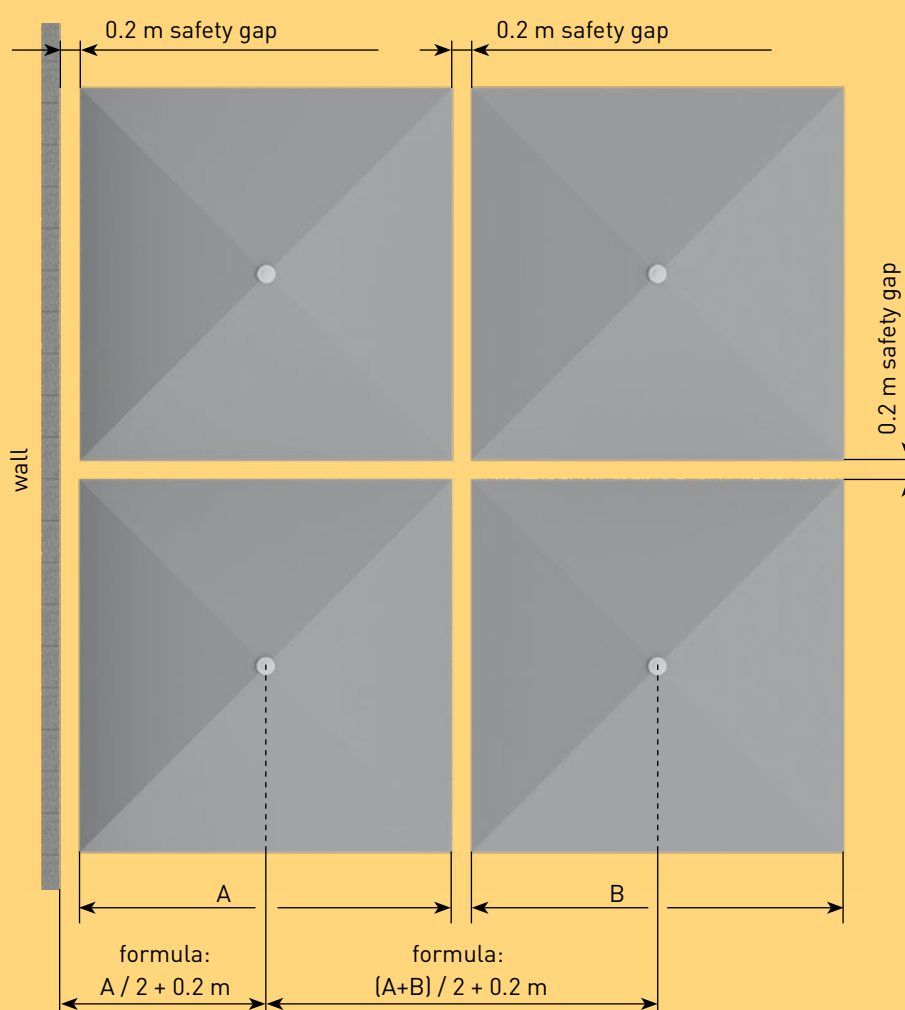

2. We are able to compensate any unevenness of the ground by adjusting the height of each individual parasol. Extra length upper tubes are available at 10 cm gradation and can be adjusted and accommodated on location.

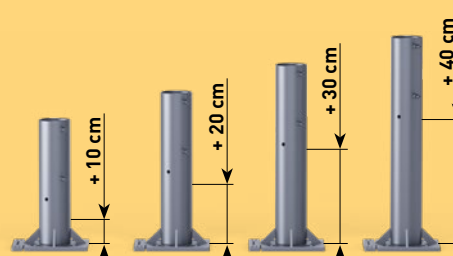

## Assembling the anchor tube

1. Slip the 16 mm washer on the M16 × 45 mm hex socket head screw.



2. Place the hex socket head screw on the long end of the 14 mm hex key provided.

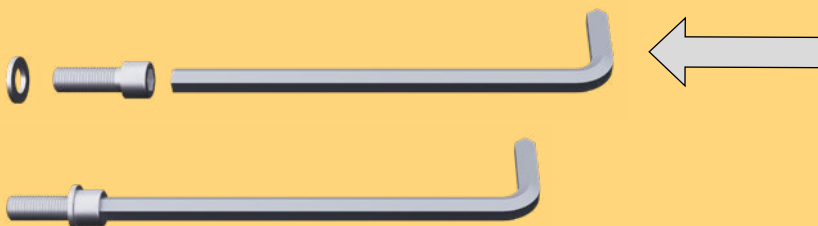

3. Push this unit through the face-end through-hole of the upper anchor tube.

4. Mount the upper anchor tube onto the lower anchor tube. The anti-twisting lock must be set into the centering hole so that the flanges lie absolutely flat.

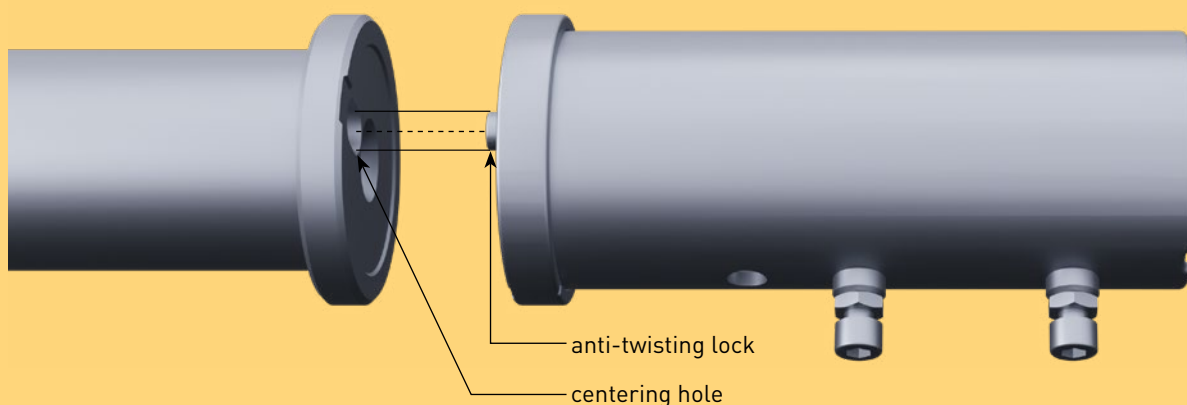

5. After the parasols have been dismantled, the slight play in the anti-twisting lock will make it difficult to re-align them precisely parallel to the wall of the house. It is therefore necessary to turn the upper anchor tube clockwise as far as it will go so that, when re-mounted, the parasols will stand in the same position as before.

Turn clockwise:



Required alignment:

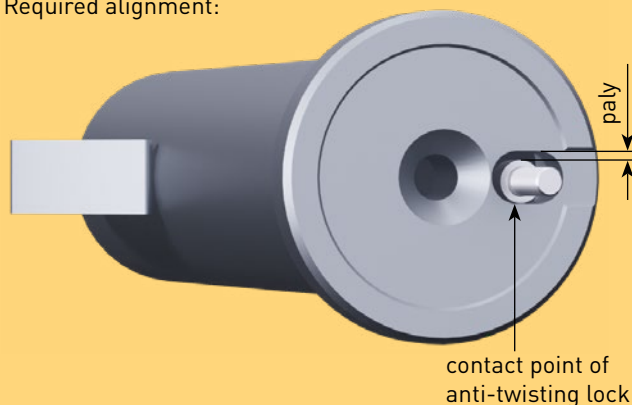



### Screws that are not tightened correctly will work loose.

If screws are not tightened firmly enough, there will not be sufficient tensile force to trigger self-locking. If the screws are tightened too firmly and overstressed, the screw connection may slacken.

- Tighten the screws manually using the hex key and extension provided. Exert as much force as possible. With the enclosed tools there is virtually no risk of overstressing.
- The correct torque for a torque wrench is:  
M16: Steel anchor tube: 210 Nm; Stainless steel anchor tube: 160 Nm.

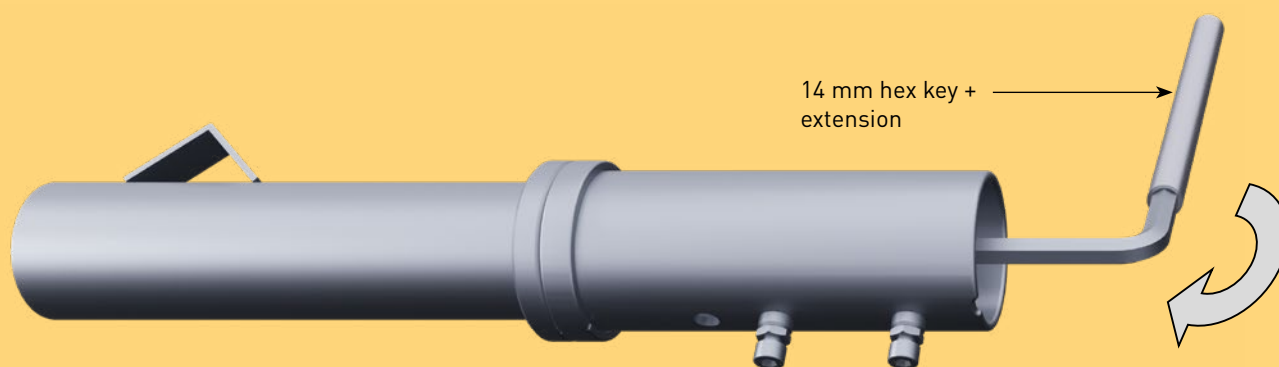

6. Do not remove the foam material inside the lower anchor tube.



### Frost can damage the lower anchor tube.

If no drainage is embedded beneath the lower anchor tube, water may flow into the tube and freeze when temperatures are below zero. Due to the different densities, the ice increases in volume and develops enough force to break the steel tube. The foam material serves to minimize this expansion force.

- Do not remove the foam material.
- Be sure to lay the drainage correctly so that water can escape.

## Embedding the anchor tube in concrete

1. Lay the concrete foundation. Consult the formwork and reinforcement plan on pages 10 and 11. For width and length of the foundation see the chart below. The depth of the foundation will depend on how sensitive the ground is to frost. We recommend a depth of at least 60 cm.

Size of parasol	Foundation: width / length
all SCHATTELLO sizes except Ø 6 m, Ø 7 m, 4 × 6 m, 5 × 5 m	50 / 50 cm
Ø 6 m, Ø 7 m, 4 × 6 m, 5 × 5 m	60 / 60 cm



**Danger**

### A falling parasol can cause serious or even fatal injury.

If the foundation for the lower anchor tube is not dimensioned to match the size of the umbrella, the parasol may fall and cause injuries.

- Keep to the dimensions specified in the above chart.
- In case of poor-quality ground, opt for a larger-size foundation.



**Caution**

### The concrete foundation can be damaged by frost.

Temperatures below freezing point may have a negative impact on the concrete foundation.

- Inquire up to what depth the ground of the designated parasol location is frost-proof and choose the size of the concrete foundation accordingly.

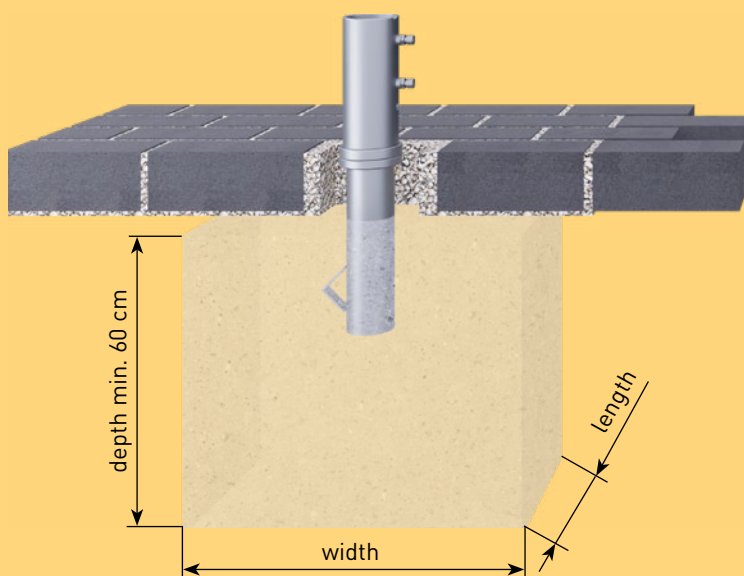

2. The following chart shows the volume calculation for the foundation in cubic metres (m<sup>3</sup>). It may help you to estimate the amount of material required.

width / length	depth	volume
50 / 50 cm	60 cm	0.15 m <sup>3</sup>
50 / 50 cm	70 cm	0.18 m <sup>3</sup>
50 / 50 cm	80 cm	0.20 m <sup>3</sup>
50 / 50 cm	90 cm	0.23 m <sup>3</sup>
50 / 50 cm	100 cm	0.25 m <sup>3</sup>

width / length	depth	volume
60 / 60 cm	60 cm	0.22 m <sup>3</sup>
60 / 60 cm	70 cm	0.25 m <sup>3</sup>
60 / 60 cm	80 cm	0.29 m <sup>3</sup>
60 / 60 cm	90 cm	0.33 m <sup>3</sup>
60 / 60 cm	100 cm	0.36 m <sup>3</sup>

3. Spread gravel (we recommend a grain size of 16-32 mm) on the bottom of the foundation, thereby allowing enough space for a recess or a drainage pipe at the end of the lower anchor tube so that rainwater can drain off. Optionally, the matching drainage unit (art. no. 357 488) can be purchased from MAY and attached.

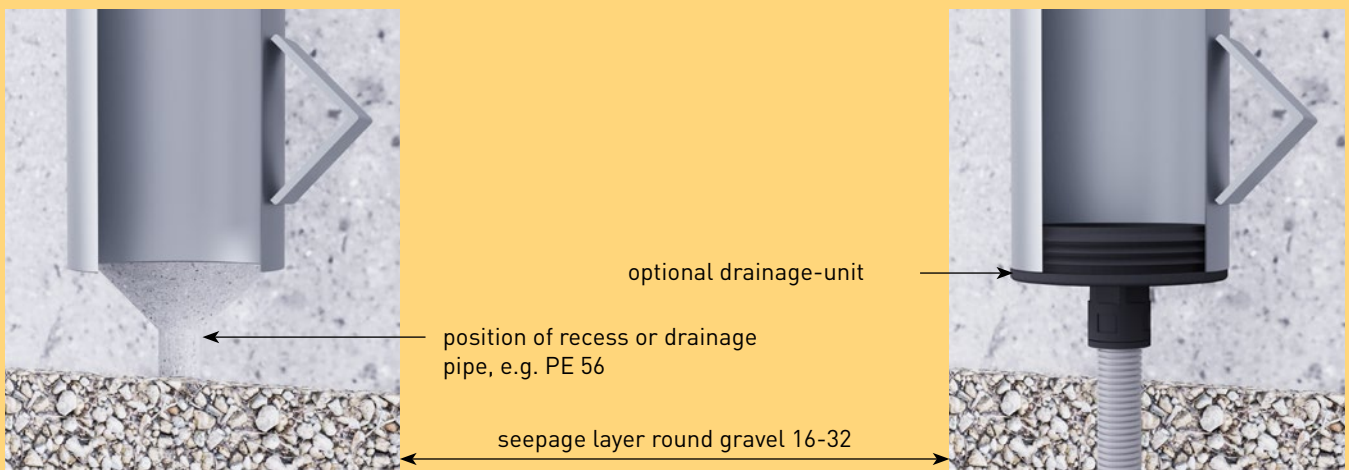

drainage-unit,  
art. no. 357 488

4. Press the lower anchor tube into the concrete foundation. Be sure to observe the embedment depth, cf. pages 12/13.
  
5. Turn the anchor tube into position, i.e. the two hex socket head screws must be either parallel or in vertical position to the wall of the house. If more than one parasol is to be installed, make sure that the hex screws of all parasols are facing in the same direction. This is for the sake of an overall attractive appearance.
  
6. This applies for paved or other floor covering only!  
Form a dome-shape block of concrete on the foundation that reaches as far as the bottom end of the flange plate. The size of the dome-shape block will depend on what further structures or types of floor covering are planned. The larger and stronger the block, the less likely that the parasol will sway in the wind. For more illustrations cf. page 12.





7. To assure that the cover plate (for winter) is flush with the ground after the upper anchor tube has been removed, (cf. illus. b) insert the lower anchor tube 4 mm deeper into the concrete than the patio surface (cf. illus. a: -to give a clearer picture, the upper anchor tube has been omitted). In this way tripping hazard is eliminated.

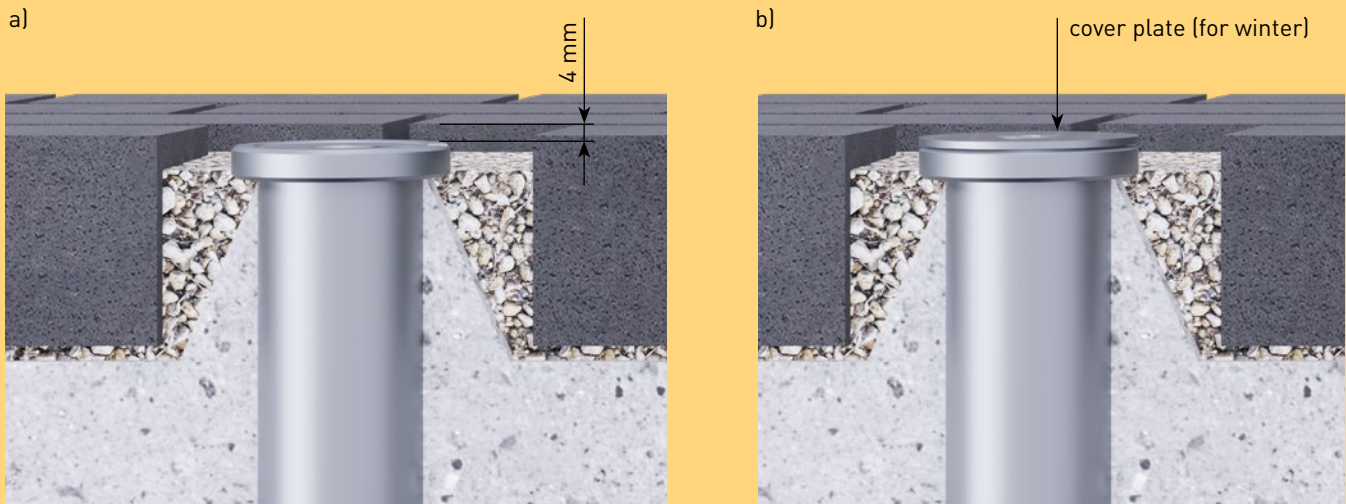

8. Check that the upper anchor tube is straight, using a spirit level. (cf. illus.)



Attention

**If the parasol is to be in a vertical position, the anchor tube must be embedded in the concrete absolutely vertically.**

Align the anchor tube and keep it in position until the concrete has cured completely.

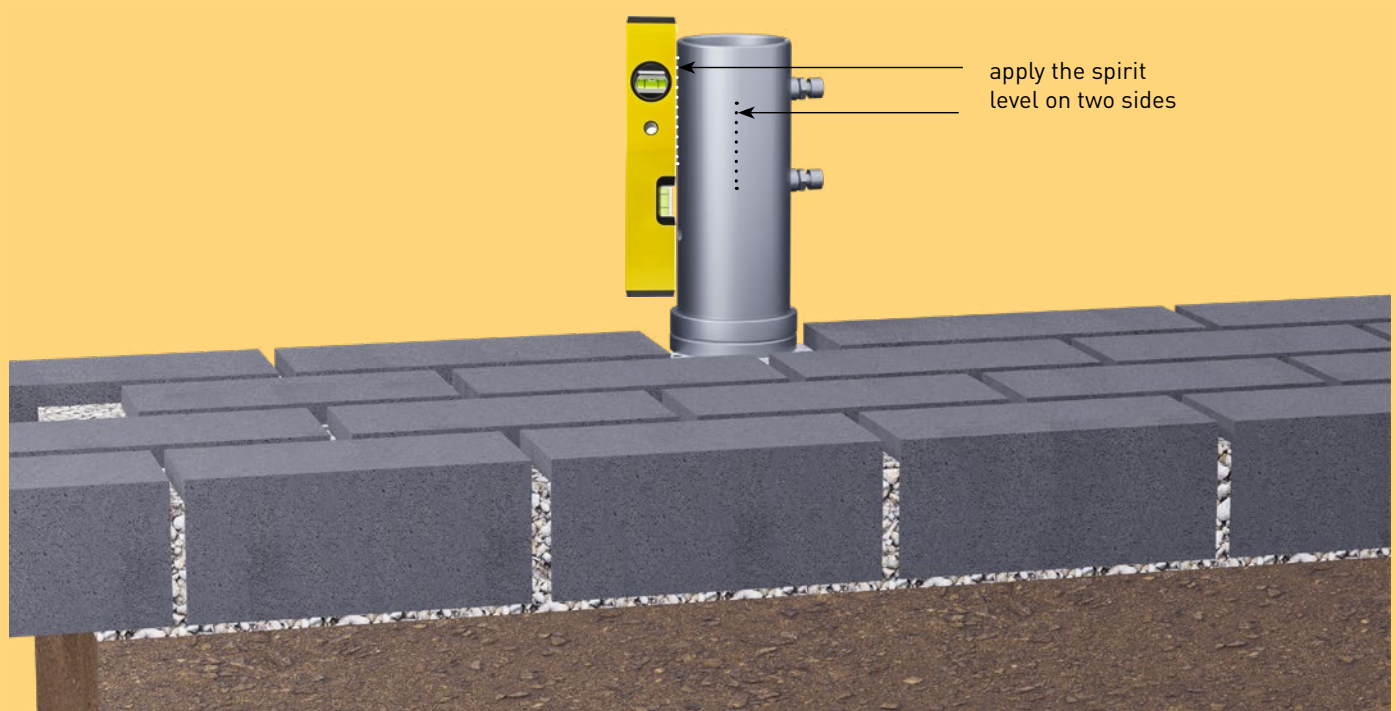



## Storage / Dismounting

1. Lift the parasol out of the anchor tube.
2. Screw off the upper anchor tube.
3. Screw the top plate onto the lower anchor tube. (cf. illus.)



**Caution**

### The thread can get damaged.

When the cover plate (for winter) is not on the lower anchor tube, sand may get washed into the flanks of the thread. As sand is harder than steel, the thread may get damaged when the screw is turned.

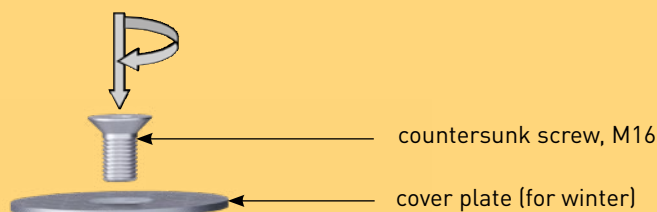

4. If you have two or more parasols, it is advisable to mark them and their installation option (e.g. with metal-stamped numerals or using a waterproof marker) as soon as they have been dismantled (e.g. for winter storage).



**Tip**

### Marking saves a lot of time and helps to keep things in order.

If clearly marked, each parasol can easily be assigned to its proper location and reerected parallel to the wall of the house or next to the others.

- For clear and easy later assignment use the same number to mark the centre pole, the upper anchor tube and the lower anchor tube. For example, for parasol No. 1, all three parts should carry number 1, all three parts of parasol No. 2 should be marked with a 2, etc.

5. Grease the screws regularly to prevent them from rusting.

# Foundation formwork and reinforcement plan

ground plan

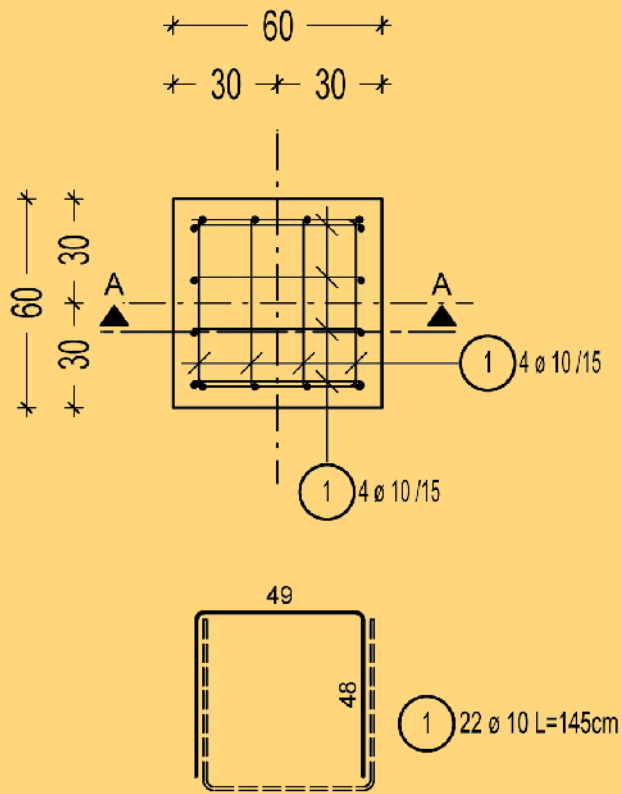

cross section A - A

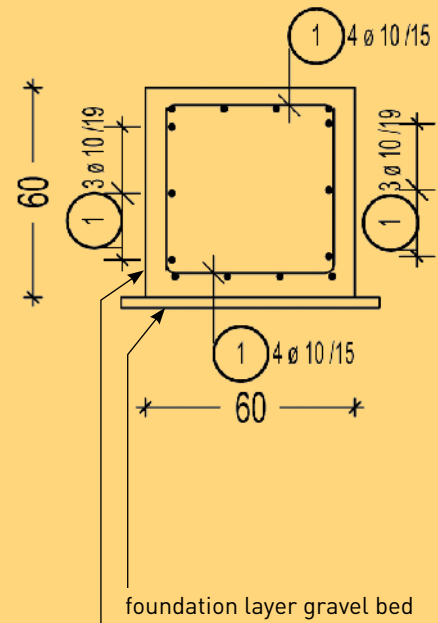

Mounting and securing of parasol in central position. Reinforcement to be placed to suit the anchorage.

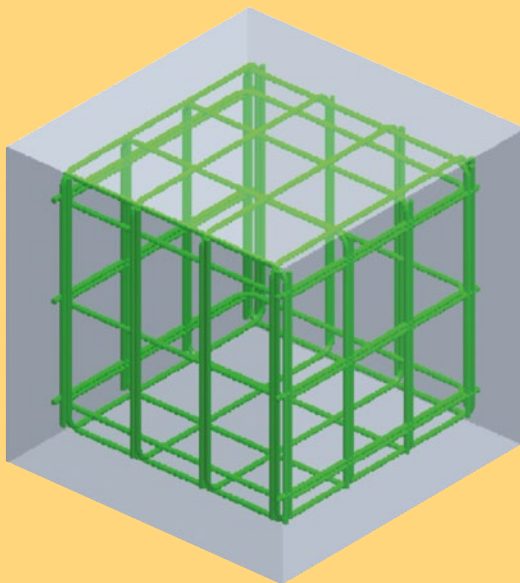

1. The allowable footing pressure must be 200 kN/m<sup>2</sup>. This must be certified in a geotechnical report by an expert soil surveyor.

2. Bar details - bending shape:

- quantity: 22 pieces
- diameter: Ø 10 mm
- length each: 1.45 m
- total length: 31.9 m (22 × 1.45 m)
- weight: 19.68 kg
- dimensioned bending shape: not true to scale

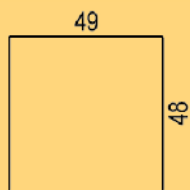

3. Minimum values for bar bending roll diameter dBr for reinforcing steel B500B according to DIN EN 1992 -1-1/NA:2011-01 Chart NA.8.1.

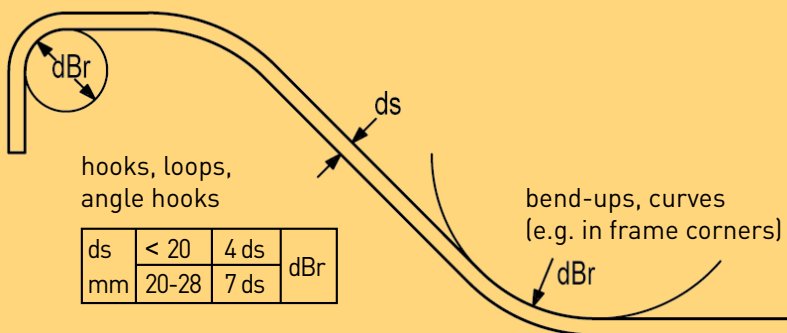

ds	< 20	4 ds	dBr
mm	20-28	7 ds	

concrete cover at right angles to the curvature	> 10 cm and > 7 ds	10 ds	dBr
	> 5 cm and > 3 ds	15 ds	
	> 5 cm and > 3 ds	20 ds	

Bend measurements are external measurements.

4. Nominal dimension for concrete cover (nom C):

- foundation top 5.5 cm
- foundation bottom 5.5 cm
- foundation sides 5.5 cm

5. Construction steel B500 A / B500 B:

- with de-icing salt: grade of concrete C30/37 (LP), consistency F3, exposure classes XC4, XD3, XF4, moisture class WF
- without de-icing salt: grade of concrete C25/30 (LP), consistency F3, exposure classes XC2, XF1, moisture class WF

## Extra length lower anchor tube

There are various terrace structures for which standard-length lower anchor tubes are not long enough, e.g. those with high floor tiles or with wooden terrace constructions. For static reasons it is essential to observe an embedment depth of min. 175 mm. Otherwise the lower anchor tube will not be sufficiently anchored in the foundation. This measurement does not include the dome-shaped concrete block. Lower anchor tubes are available in the following additional lengths: +10, +20, +30 and +40 cm. These can be delivered from our stock at any time. Lengths exceeding those quoted can be custom-made after consultation with the MAY company.

standard length:

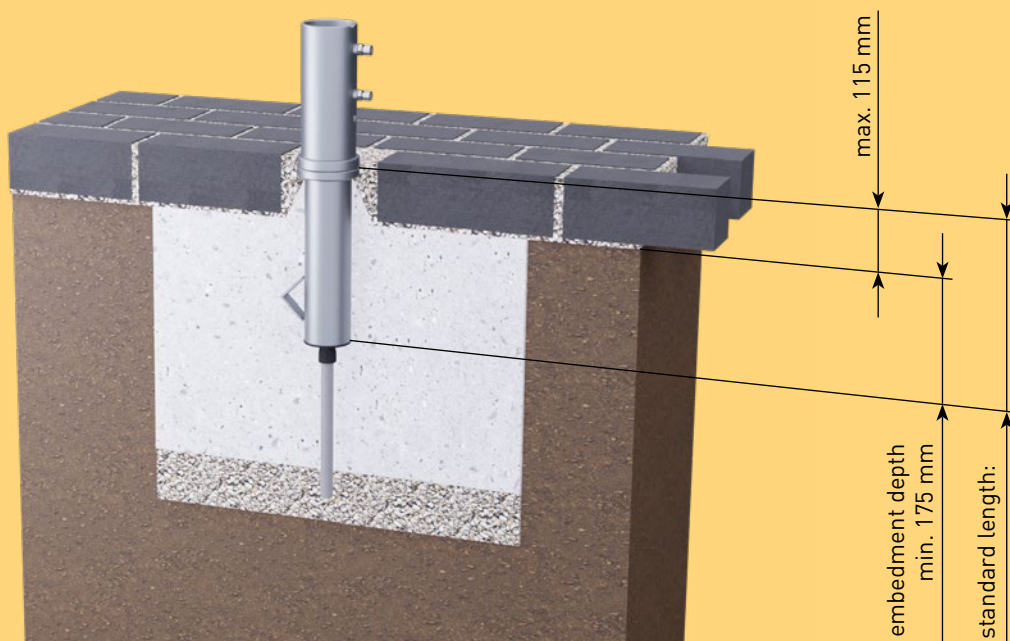

extra length +10 cm:

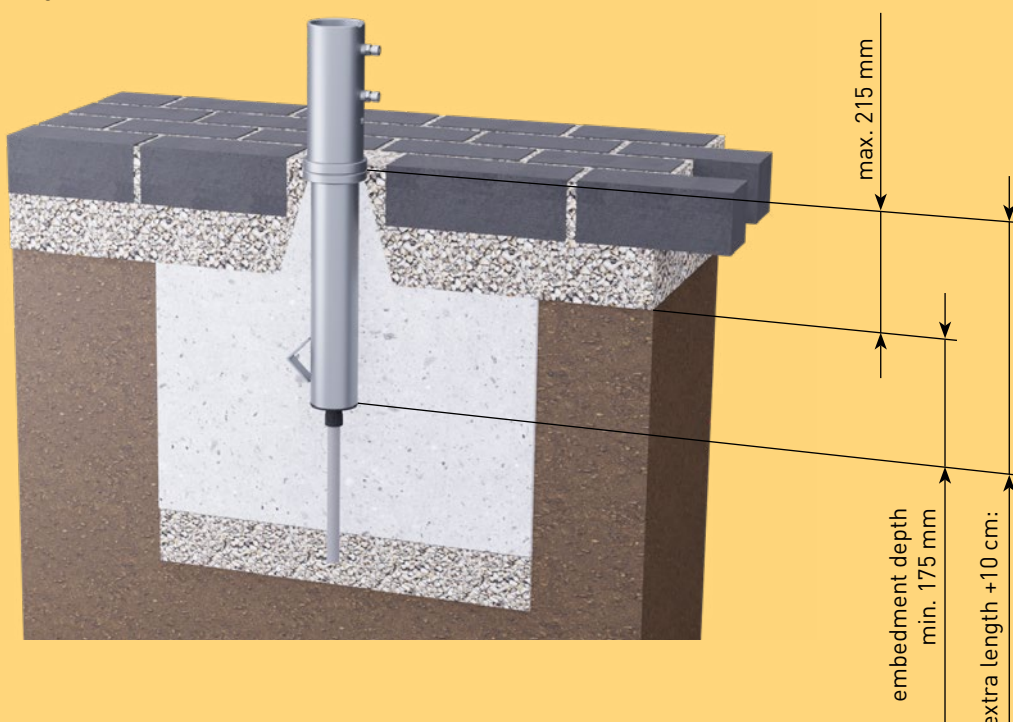

extra length +20 cm:

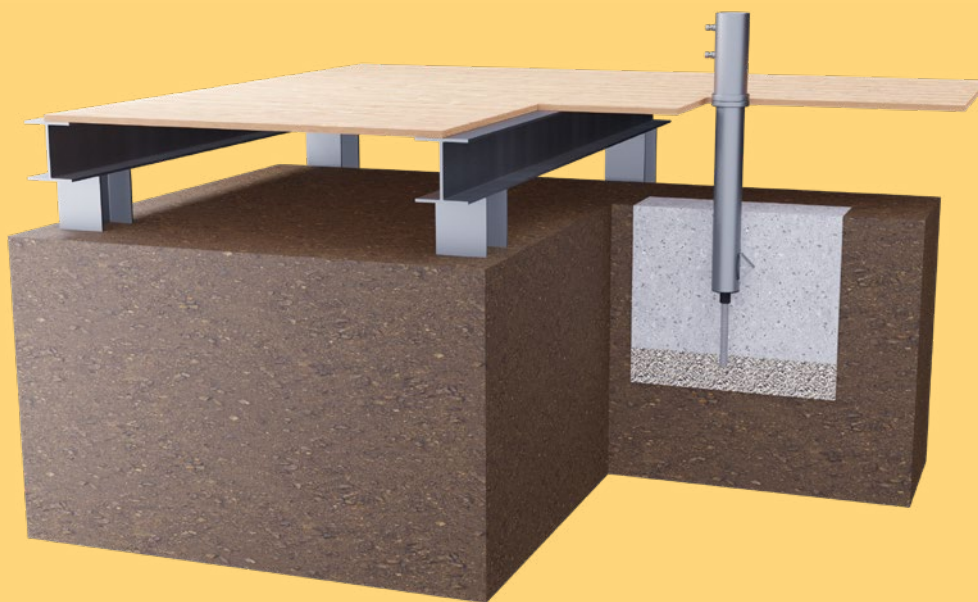
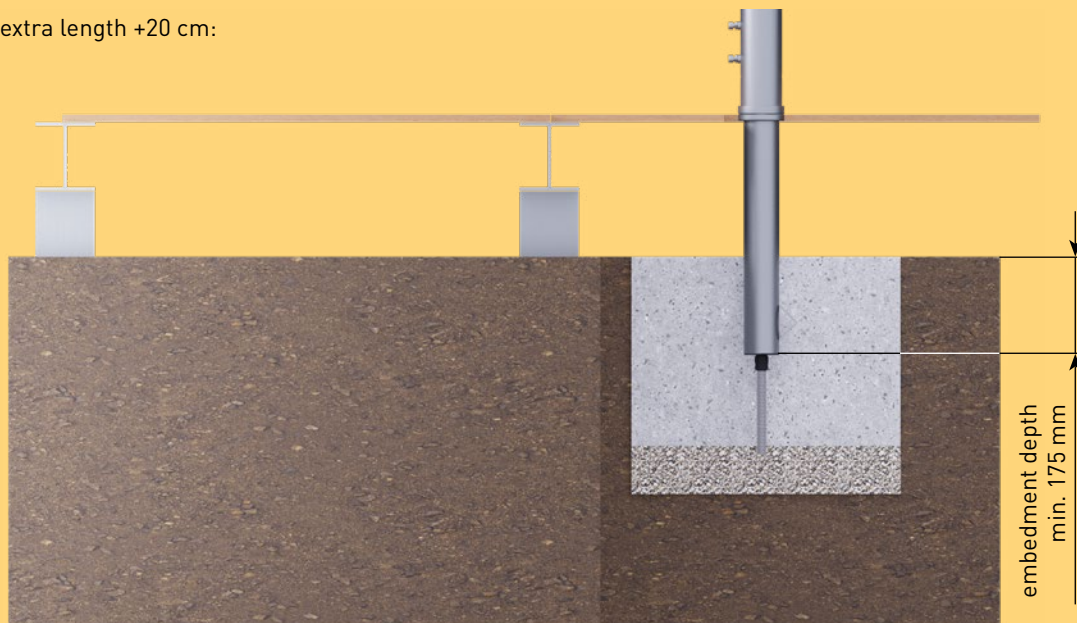



## Spare parts

upper anchor tube 1) 2), complete as shown,  
art. no. 200 005

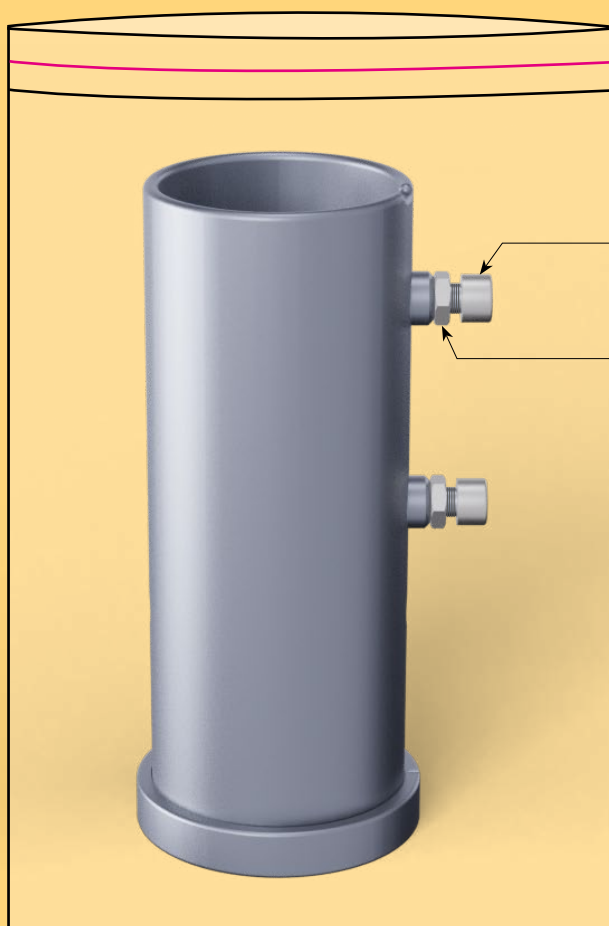

cylinder head screw M10×25 mm, 2×,  
(hex key 8 mm), art. no. 200 674

flat nut M10, 2×,  
(open-end spanner 17 mm),  
art. no. 200 653

standard parts, package 2,  
art. no. 351 186

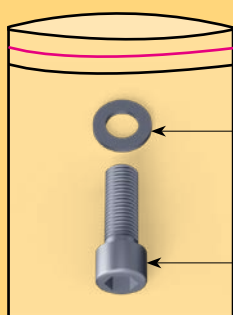

washer M16,  
art. no. 200 913

cylinder head screw M16 × 45 mm,  
(hex key 14 mm), art. no. 200 156

tools, package 6,  
art. no. 350 794

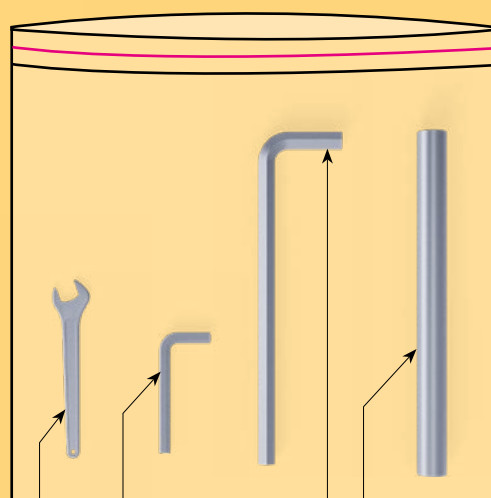

hex key 8 mm,  
art. no. 200 136

extension,  
art. no. 200 152

open-end spanner 17 mm,  
art. no. 200 870

hex key 14 mm,  
art. no. 200 134



lower anchor tube 1), complete as shown,  
art. no. 200 004

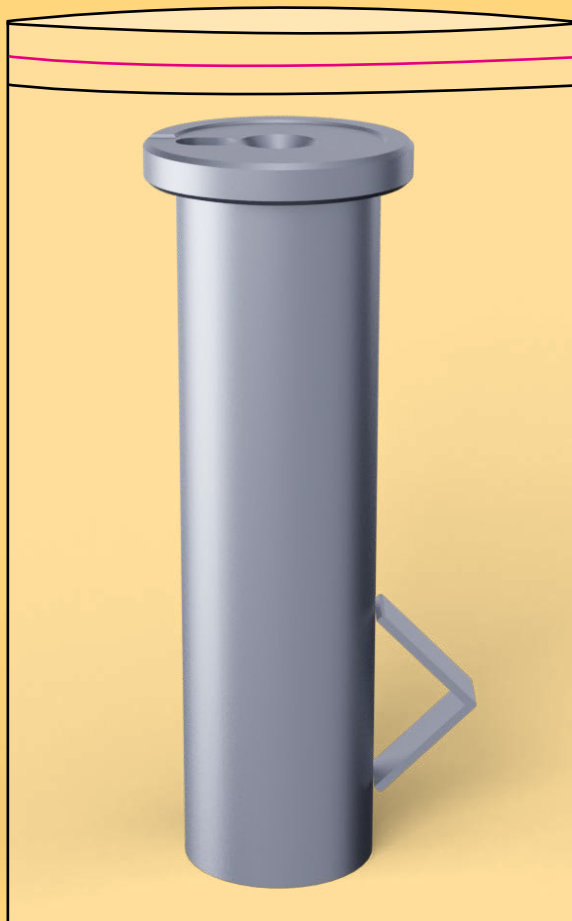

cover plate (for winter), package 2,  
art. no. 350 796

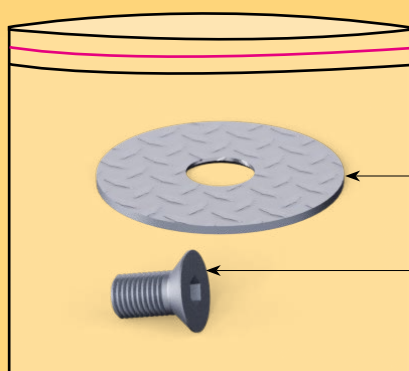

cover plate (for winter),  
art. no. 350 127

countersunk screws M6 × 30 mm,  
(hex key 10 mm), art. no. 200 150

Options: <sup>1)</sup>extra length: +10 cm, +20 cm, +30 cm, +40 cm

<sup>2)</sup>powder coating: RAL9010, RAL9006, RAL7016

