

# JETSURF®



**BORN FOR FUN**

**/ CATALOGUE**



# CONTENTS

01  
PETROL  
SURFBOARDS  
6

02  
ELECTRIC  
SURFBOARDS  
22

03  
SKATEBOARDS  
30

04  
WEAR  
38

05  
RACING  
42



## HOW YOU'VE SEEN US

2010

*JetSurf*

2012

*JetSurf*

2016

*JetSurf*  
MOTORIZED SURFBOARD

2018

**JETSURF**  
MOTORIZED SURFBOARD

2020

**JETSURF**  
MOTORIZED SURFBOARD

2021

**JETSURF**



# 01

PETROL  
SURFBOARDS



**SPORT**

**2023**



**FEATURES**



• 90 ccm engine with carburetor.



• Compatible with the Tube.



• Main and side carbon fibre fins (no FCS).



• Dual foot bindings for both riding positions – REGULAR & GOOFY.

**GRAPHIC DESIGN**



PERFECT BLUE



WHITE GREY



FLUO YELLOW

**LET THE JOURNEY COMMENCE!**

Lenght	Width	Height	Weight	Displacement	Cruising range	Mixture preparation	Certification
180 cm	60 cm	15 cm	18,5 kg	90 cc	40 min	carburetor	/

**SPORT** PRICE (excluding VAT) **8 790 €**



# ADVENTURE DFI

2023



## CROWD FAVORITE!

Length	Width	Height	Weight	Displacement	Cruising range	Mixture preparation	Certification
180 cm	60 cm	15 cm	20 kg	100 cc	60 min	fuel injection	EPA CE

ADVENTURE DFI PRICE (excluding VAT) **10 890 €**

## FEATURES



• Intake screen – protection of jet-pump from debris.



• FCS main and side fins – fast and simple click on / off system.



• Dual foot bindings for both riding positions – REGULAR & GOOFY.

## GRAPHIC DESIGN



FLUO YELLOW



WHITE GREY



FLUO ORANGE

# ADVENTURE DFI PLUS

2023

## FEATURES



• Intake screen – protection of jet-pump from debris.

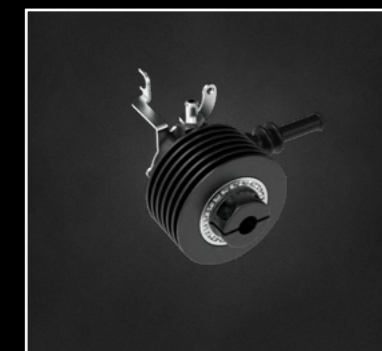

• Alternator for charging independence.



• FCS main and side fins – fast and simple click on / off system.

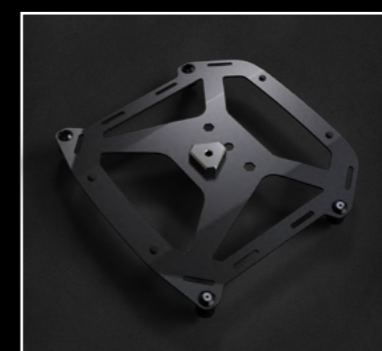

• Smart carrying system for duffel & fuel tank.

## GRAPHIC DESIGN

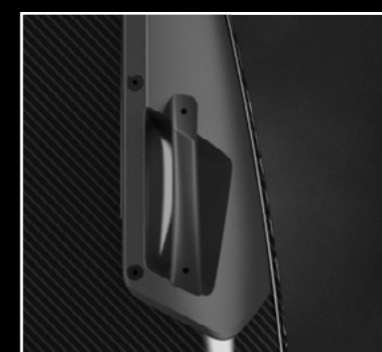

• Protective covers for more durability.



FLUO RED



## BORN TO EXPLORE!

Length	Width	Height	Weight	Displacement	Cruising range	Mixture preparation	Certification
180 cm	60 cm	15 cm	22 kg	100 cc	180 min with extra fuel canister	fuel injection	CEPA CE

ADVENTURE DFI PLUS PRICE (excluding VAT) 12 390 €

### EXTRA EQUIPMENT INCLUDED:

- Ratchet straps.
- Travel bag for maximum protection

**RACE DFI**

**2023**

**NEW**

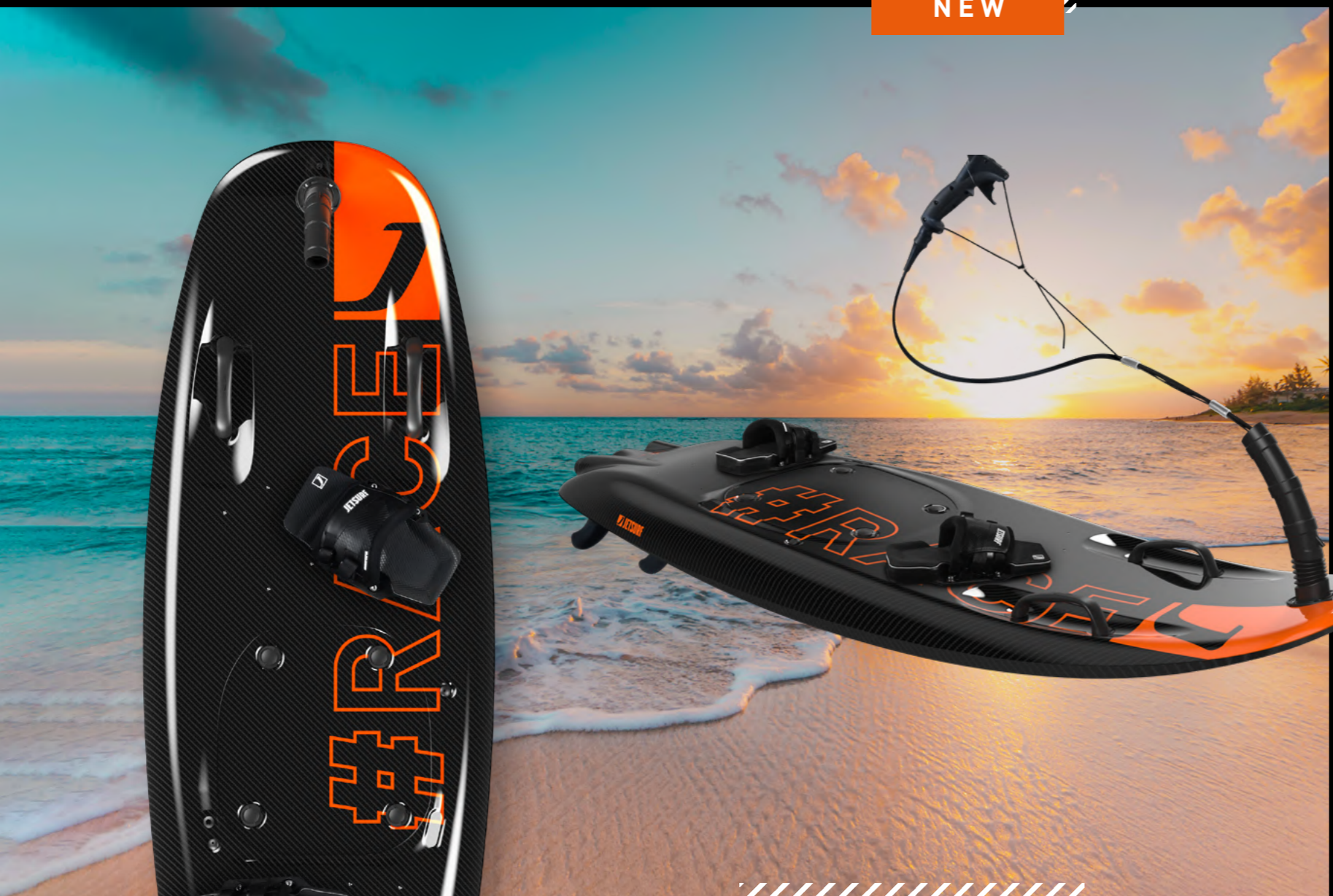

**FEATURES**



• Perfect handling

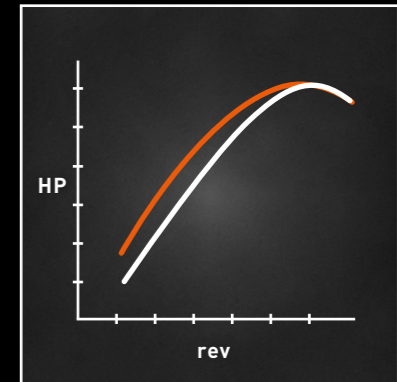

• NEW exhaust with silencer  
- higher power and noise reduction



• FCS main and side fins – fast and simple click on / off system.

**NEW GRAPHIC DESIGN**

**UNLEASH THE JOY!**

Lenght	Width	Height	Weight	Displacement	Cruising range	Mixture preparation	Certification
180 cm	60 cm	15 cm	19,5 kg	100 cc	60 min	fuel injection	EPA CE

**RACE DFI PRICE (excluding VAT) 12 390 €**



FLUO ORANGE

FLUO YELLOW

CARBON



# CRUISER DFI

2024

ALL-NEW



## UNLEASH THE JOY!

Lenght	Width	Height	Weight	Displacement	Cruising range	Mixture preparation	Certification
180 cm	60 cm	15 cm	20,5 kg	100 cc	60 min	fuel injection	CEPA CE

RACE DFI PRICE (excluding VAT) **12 890 €**

## FEATURES

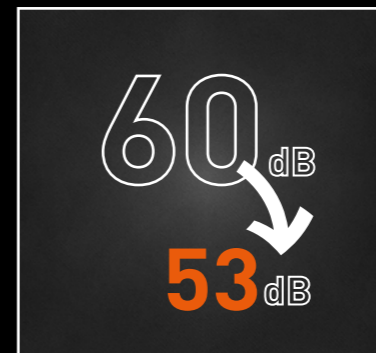

- Noise reduction.



- Handle length adjuster.

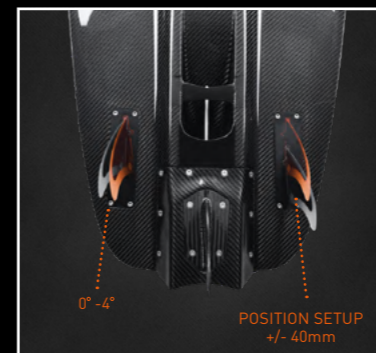

- FCS side fins with plugs for perfect fins position setup.

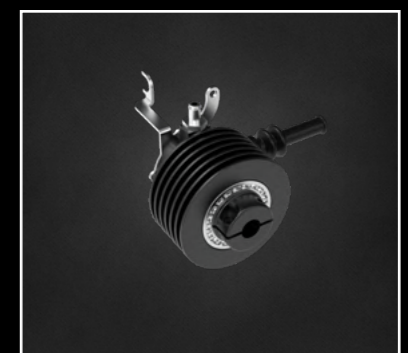

- Alternator for charging independence.

## NEW GRAPHIC DESIGN



- ECA - easy cleaning adapter.



FLUO RED

WHITE GREY

### EXTRA EQUIPMENT INCLUDED:

- Dual binding.
- NEW exhaust with silencer - higher power and noise reduction.

# TITANIUM DFI

2023



## BORN TO RACE!

Lenght	Width	Height	Weight	Displacement	Top speed	Mixture preparation	Certification
180 cm	60 cm	15 cm	18,5 kg	100 cc	62 km/h	fuel injection	/

TITANIUM DFI PRICE (excluding VAT) 13 390 €

## FEATURES

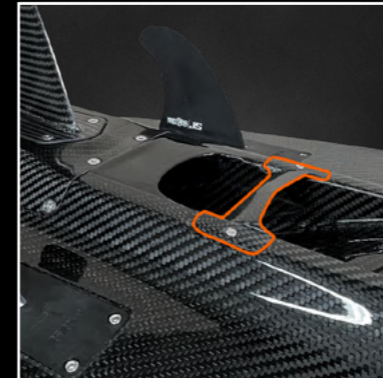

• JetPump winglet – hydrodynamics flow stimulation.



• Improved engine and exhaust system setup for higher performance.



• Redesigned hull for better turning.

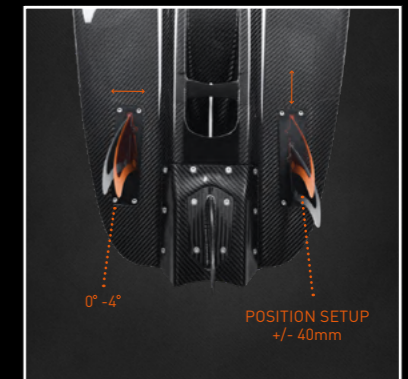

• FCS side fins with plugs for perfect fins position setup.

## GRAPHIC DESIGN



CARBON

# TITANIUM DFI RS

2023



## BORN TO RACE!

Lenght	Width	Height	Weight	Displacement	Top speed	Mixture preparation	Certification
180 cm	60 cm	15 cm	18,5 kg	100 cc	64 km/h	fuel injection	/

TITANIUM DFI RS PRICE (excluding VAT) **14 490 €**

## FEATURES

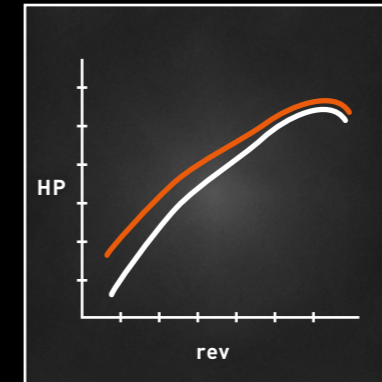

- Improved cylinder for the highest performance.



- Racing jetpump for maximum thrust with new technology for better power encrease.

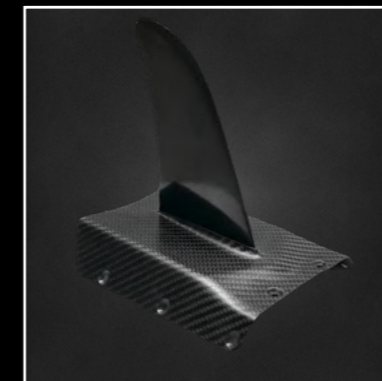

- Tougher one piece main fin for more traction in the curve.

## GRAPHIC DESIGN



CARBON

# 02

ELECTRIC  
SURFBOARDS



# ELECTRIC

2023



## SILENT POWER

Lenght	Width	Height	Weight	Cruising range	Charging time	Certification
180 cm	60 cm	15 cm	32,9 kg	25-55 min	2,5 hours	CE

	With one battery included	Extra battery
<b>ELECTRIC PRICE (excluding VAT)</b>	<b>13 890 €</b>	<b>4 990 €</b>

## FEATURES



- Dual foot bindings for both riding positions – REGULAR & GOOFY.

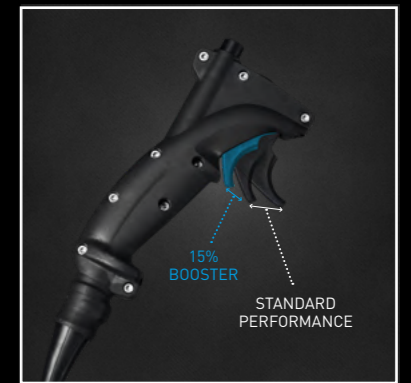

- Performance booster.

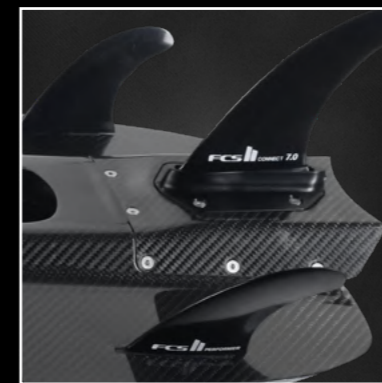

- FCS main and side fins – fast and simple click on / off system.

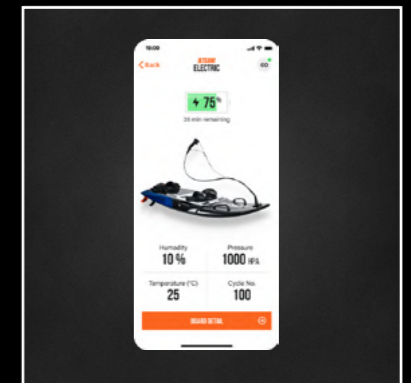

- iOS & Android compatible.

## GRAPHIC DESIGN



PROTON BLUE

- Systems for temperature, pressure, humidity and charging process monitoring
- Motor and regulator with active cooling
- Battery pack with passive cooling
- Three performance modes



ARIATOLL, MALDIVES



MUMBAI, INDIA



TEL AVIV, ISRAEL



DUBAI, UAE

# JOIN THE JETSURF FAMILY



PLAYA DEL CARMEN, MEXICO



SANTA MARTA, COLOMBIA



BUSAN, KOREA



MUSKOKA, CANADA



KOH SAMUI, THAILAND



CANCÚN, MEXICO



BLACKMORE RANCH, CALIFORNIA



DUBAI, UAE



ALGARVE, PORTUGAL



ABU DHABI, UAE

# CONNECTIVITY



DOWNLOAD NOW!

## MOBILE

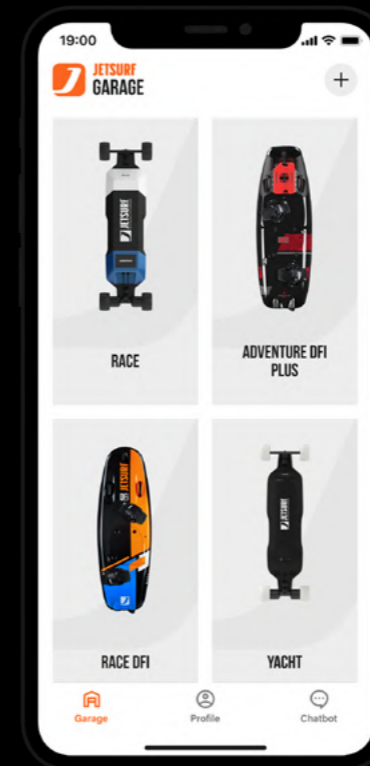

• Virtual Jetsurf garage

## WATCH



• Apple watch compatible.

Be informed about your JETSURF inventory more than ever before. With the brand new app, you can easily add JETSURF devices to your garage and monitor current data in the infotainment section. The app is available on App Store & Google Play platforms or scan one of the following QR Codes.



# 03

SKATEBOARDS





RACE

2023



UNLEASH THE JOY

Lenght	Width	Height	Weight	Max load	Top speed	Range up to
100 cm	25 cm	3 cm	11,5 kg	120 kg	50 km/h	40 km

RACE PRICE (excluding VAT) 1 810 €

FEATURES



- Remote controller with 3 speed modes and integrated display with all handy information about the board.

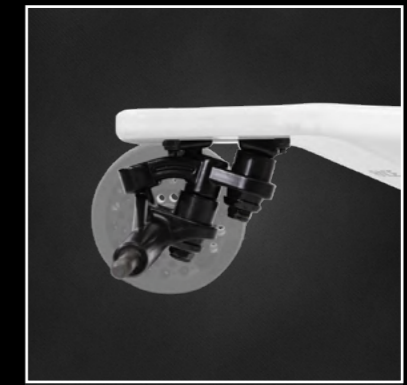

- Double kingpin trucks for high stability and ultimate carving experience.



- Enlarged 120mm AIRLESS wheels for smooth ride on all types of surfaces.

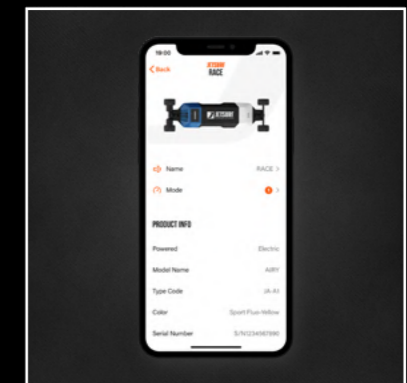

- iOS & Android compatible.

GRAPHIC DESIGN



# YACHT

2023



## COOL RIDE!

Length	Width	Height	Weight	Max load	Top speed	Range up to
100 cm	25 cm	3 cm	11,5 kg	120 kg	50 km/h	40 km

YACHT PRICE (excluding VAT) **2 470 €**

## FEATURES



- Premium remote controller with teak wood details.

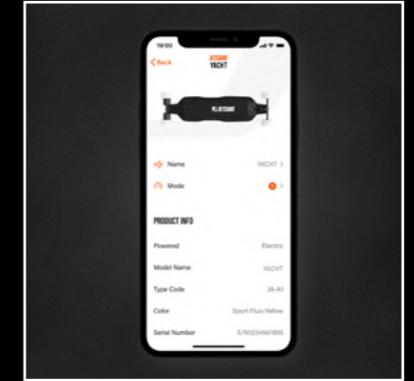

- iOS & Android compatible.



- White airless wheels.



- Luxury top of the board made from teak wood.

## GRAPHIC DESIGN

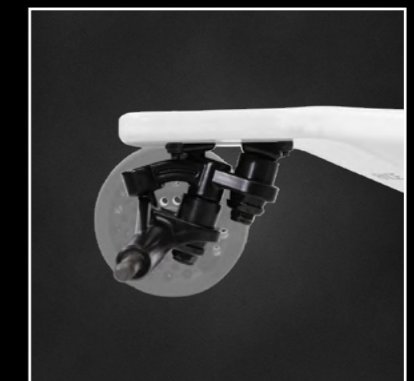

- Double kingpin trucks for high stability and ultimate carving experience.



CIRCUIT BRNO, CZECH REP.



LAGO DI GARDA, ITALY



CIRCUIT BRNO, CZECH REP.



MIAMI, USA



# ALWAYS PUSH THE BOUNDARIES



KAZAN, RUSSIA



MONTE CARLO, MONACO



LA TESTE-DE-BUCH, FRANCE



KAZAN, RUSSIA



PARDUBICE, CZECH REP.



SEBRING, USA



CIRCUIT BRNO, CZECH REP.



BRUSEL, BELGIUM



CIRCUIT BRNO, CZECH REP.



# 04

WEAR



# WEAR



## SWIMWEAR



## TEES



## RACE CAP



## PONCHOS





# 05

RACING



# MOTOSURF WORLD CHAMPIONSHIP



# UIM

Since in 1922, The Union Internationale Motonautique (UIM), has been the world governing body for all powerboating activities. It is fully recognized by the International Olympic Committee (IOC). MotoSurf has been a member since 2019



# MSWC

Officially recognized sport discipline by the Union Internationale Motonautique (UIM). MotoSurf is the youngest, fastest growing and most affordable powerboating discipline.



# ECO FRIENDLY

1 TREE for every manufactured board to offset the impact



WE HAVE PLANT MORE THAN 10 THOUSAND TREES.

T. CORSER, AUSTRALIA



A. COLLEY, UK



L. ZÁHORSKÝ, CZECH REP.



S. KOVÁR, CZECH REP.



# READY TO RACE

A. ALSABAH, KUWAIT



HAEMILY, SOUTH KOREA



CH. MÜLLER, GERMANY



B. ŠULOVÁ, CZECH REP.



D. SVIRAČ, CROATIA



J. GULIANO, USA

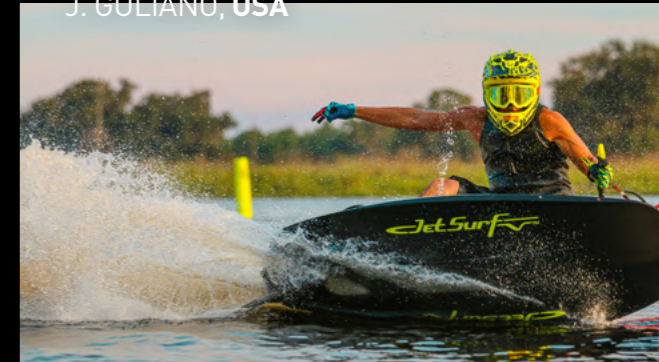

S. GANTAR, SLOVENIA



C. CARPI, ITALY



D. KIM, SOUTH KOREA



B. JANOŠKOVÁ, CZECH REP.







BETTER THAN  
EVER BEFORE

 JETSURF

 [www.jetsurf.com](http://www.jetsurf.com)

 [info@jetsurf.com](mailto:info@jetsurf.com)

 +420 774 602 701

 @jetsurf\_official

 Jetsurf-official



OPEN A WEBSITE



OPEN A CATALOGUE

VOL. 1