

PristineHydro™

WATER REVIVAL SYSTEM INSTALLATION MANUAL



TABLE OF CONTENTS

- Purchase Records **4**
- Introduction **5**
- Component List **6**
- Diagram **7, 8**
- Specifications **9**
- Quick Connect Guide **10**
- Set-up **11**
- Filter Replacement Schedule **12**
- Filter Replacement Procedure **13**
- Troubleshooting **14**
- Conditions **15**
- Limited Warranty **16**



WATER REVIVAL SYSTEM

PURCHASE RECORDS

Please fill out the following information at the time of installation.

SAVE FOR FUTURE REFERENCE

MODEL: WRS-TP4

PURCHASE DATE:

INSTALL DATE:

SOLD BY:

INSTALLED BY:

SERVICE CENTER PHONE NUMBER:



PristineHydro™

WATER REVIVAL SYSTEM

INTRODUCTION

Congratulations on your purchase of a **PristineHydro™ WATER REVIVAL SYSTEM**. When properly maintained, this system will provide you with years of trouble-free operation. The next sections contain important information on the proper care and maintenance of your system. Please take the time to read through this information carefully.

The cartridges in this system must only be replaced with **PristineHydro Authorized Replacement Filters** and on a regular basis in order to maintain system efficiency and to ensure water production that is 100% free of all undesirable acids and contaminants. These cartridges are designed to work together as a system and should be replaced at the recommended intervals. Any significant change in performance of the system should be investigated promptly to avoid secondary damage or deterioration to other parts of the system.

CAUTION: Improperly installed systems could result in water damage due to leaks and/or flooding. Proper installation of this system requires proficiency with standard sink plumbing and proper use of hand tools. Unless you possess plumbing skills, we recommend you consult a licensed professional plumber or contractor.

NOTE: Water systems like to be run regularly in order to maintain efficiency and sanitation. With the absence of a Water Storage Tank in this Travel System, there is typically a low volume of treated water involved, however, there is still some chance of contamination. Historically, bacteria, if any, will be on the reject side and will flush out. If your system experiences a period of dormancy of 2 weeks or more, it is always a good practice to discard the first gallon or so. Once the average TDS is achieved, begin to collect your water for use and/or storage.

PristineHydro™



WATER REVIVAL SYSTEM

COMPONENT LIST

Your new **WATER REVIVAL SYSTEM** should include the following items. If any items are missing, please contact your supplier, retailer or any local professional plumbing service.

Please take a few moments to check all the following components:

- **Water Revival System Assembly**
- **Travel Case**
- **Faucet Adapters**
- **TDS Meter**

Recommended Tool List

Before you begin, make sure the faucet adapters and tools are complete and ready to use.

- **Pliers**
- **Screwdriver**
- **Wrench or Adjustable Wrench**



PristineHydro™

WATER REVIVAL SYSTEM

DIAGRAM

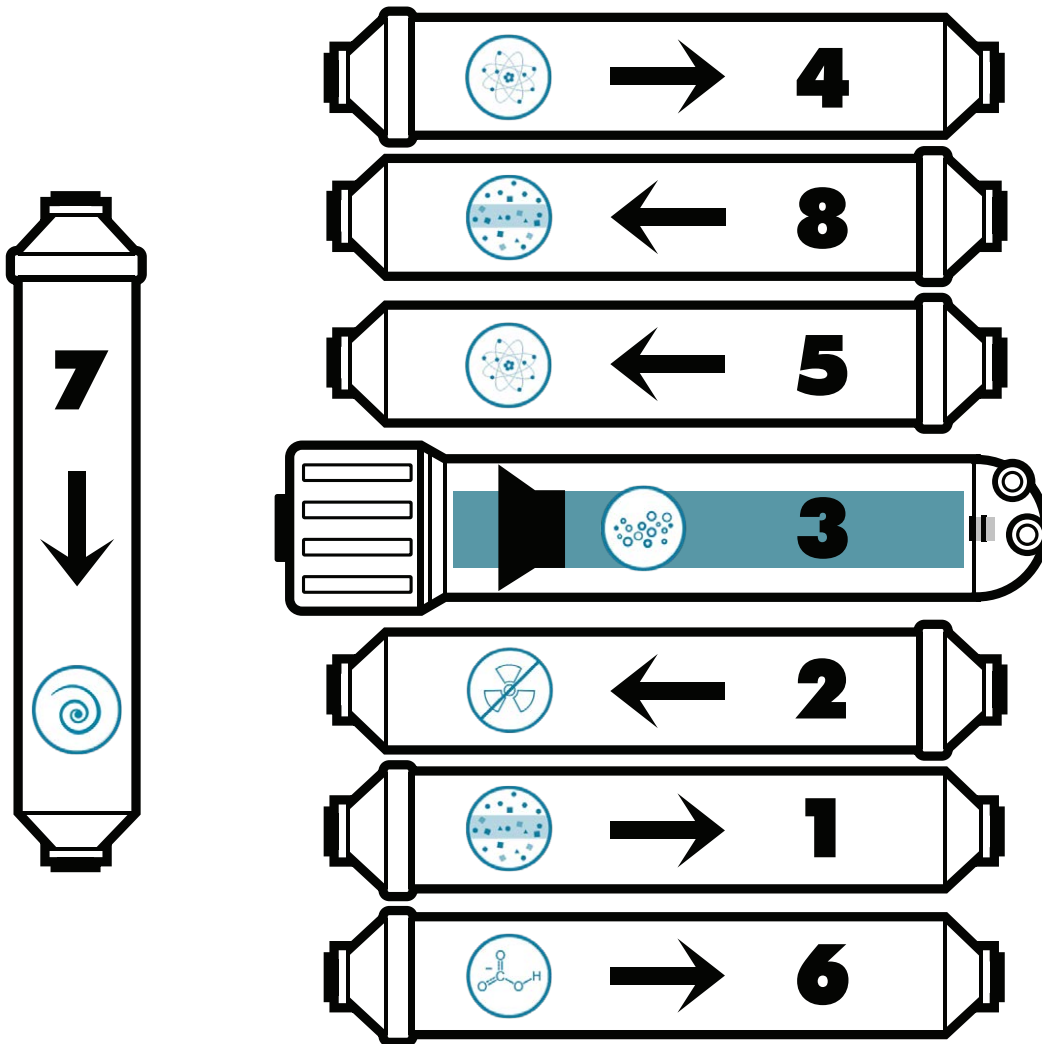

1. 5 Micron
2. KDF + Carbon
3. High Efficiency Reverse Osmosis Membrane
4. Primary Deionization
5. Secondary Deionization
6. Remineralization
7. Restructuring + Recharging
8. Coconut Carbon

PristineHydro™



WATER REVIVAL SYSTEM

DIAGRAM

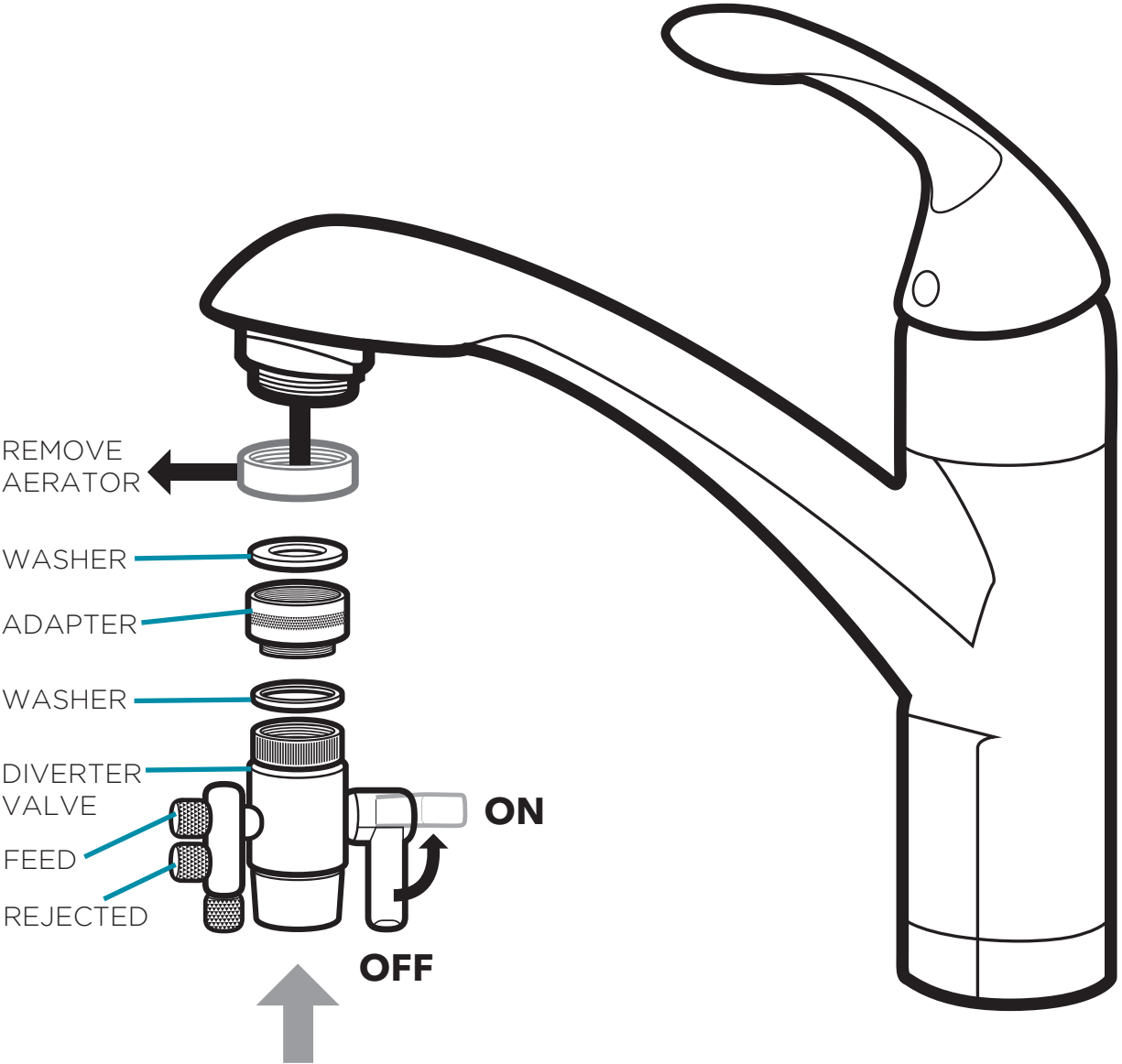

WATER REVIVAL SYSTEM

SPECIFICATIONS

SYSTEM PERFORMANCE

Daily Production Rate..... 150 GPD Rated Membrane

FEED WATER REQUIREMENTS

Feed Water Potable, municipal water
Feed Pressure 60 to 80 PSI
Feed Temperature 45 Deg. F. to 100 Deg. F.
Total Dissolved Solids 600 PPM or less
Chlorine <1.0 mg/l max
pH 4-8
Turbidity <1.0 NTU (visibly clear)
SDI <5
Iron 0.2 mg/l or less
Manganese 0.03 mg/l or less

**If any of the parameters are exceeded, please contact the supplier.
Pre-treatment or special adjustments may be required.**



WATER REVIVAL SYSTEM

QUICK CONNECT GUIDE

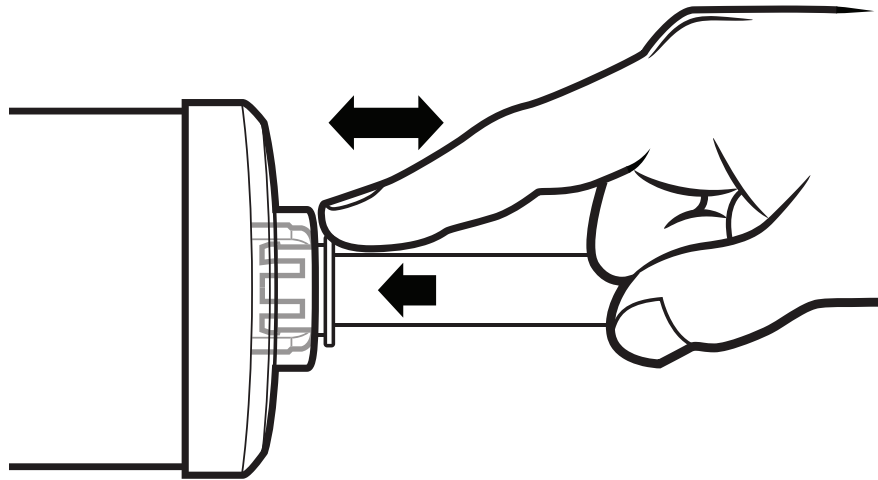

TO ATTACH TUBING

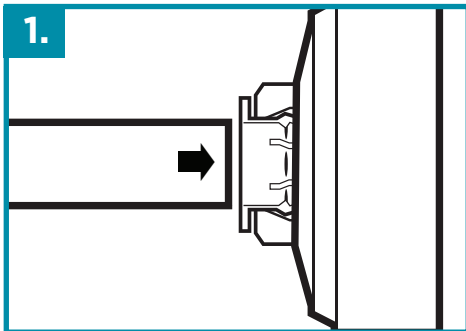

Push tubing straight in as far as it will go.

TO RELEASE TUBING

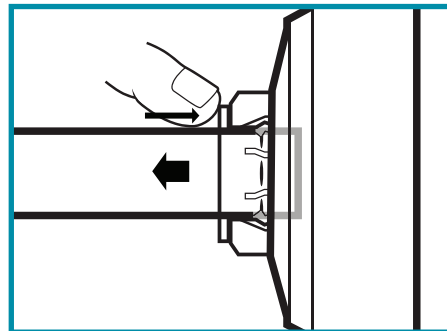

Push in collet while simultaneously pulling on tubing.

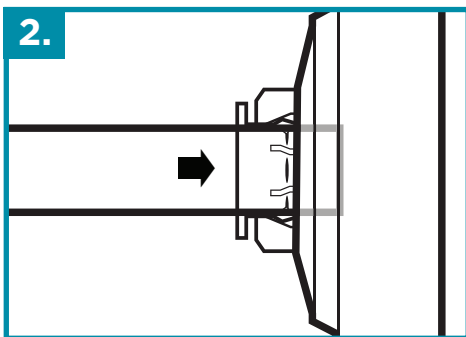

Tubing is secured in position.

TO INSERT LOCKING CLIP

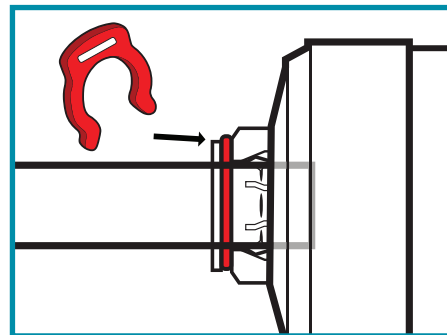

Optional RED locking clip slides between collet and fitting.



WATER REVIVAL SYSTEM

SET-UP



1. REMOVE AERATOR from the faucet you are trying to attach the system to. If it's too tight to remove by hand, use a wrench or pliers. If you have never removed the aerator before, you may find that it is very difficult to remove.

NOTE: Some faucet aerators require special service tools for removal. Consult with the manufacture of your faucet for further details.



2. DIVERTER VALVE - Depending upon the thread type and depth of your existing faucet you may need to install one of the provided faucet adapters. Once determined, firmly tighten adapter in place of aerator (See pg. 8). Now you can fasten the diverter valve to the faucet. Be careful not to over tighten and do not use plumber's tape of any kind.



3. PRODUCTION - Once the Diverter Valve is firmly in place, Turn the Diverter Valve ON by moving the lever to the horizontal position. Now it is safe to turn on the COLD-WATER supply.

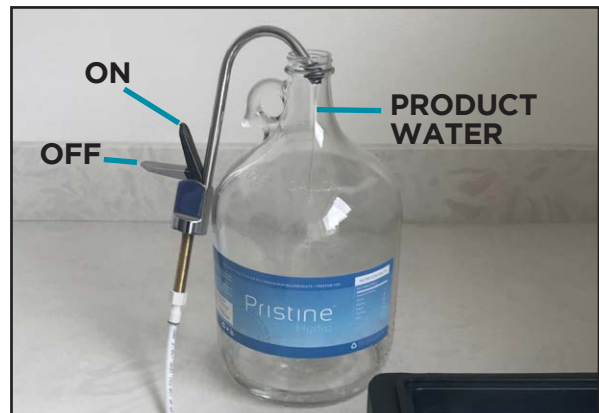

4. DISPENSE PRODUCT WATER by placing the system's Faucet lever in the OPEN position. Waste water should exit through the 1/4" BLACK Line and out the Diverter Valve at about the same rate as the product water.

NOTE: On new systems or after filter changes, do not drink the water from the system until the flow is clear, steady, and with no air or odor. Most systems will eventually break in around 40 ppm.

DO NOT LEAVE THE SYSTEM UNATTENDED WHILE MAKING WATER

PristineHydro™



WATER REVIVAL SYSTEM

FILTER REPLACEMENT SCHEDULE

STAGE	DESCRIPTION	AVERAGE SERVICE LIFE	DATE	DATE	DATE	DATE	DATE	DATE	DATE
1	5 Micron	12 Months							
2, 3	KDF + Carbon	12 Months							
4	High Efficiency Reverse Osmosis Membrane	36 Months							
5	Primary Deionization	24 Months							
6	Secondary Deionization	24 Months							
7, 8	Remineralization + Coconut Carbon	36 Months							
9, 10	Restructuring + Recharging	N/A							



NOTE: Most customers prefer to replace filters pro-actively in order to maintain PristineHydro™ water quality standards rather than wait for complete filter component degradation. Average Service Life is based on “normal” usage and average feed water quality. Actual filter life will vary with frequency of use, total volume produced, and most importantly, source water quality. If you are a heavy user or your water supply is of below average quality, you may need to replace filters more frequently. We highly recommend periodically checking your system’s output water TDS and replacing filters regularly in order to maintain high system performance.

WATER REVIVAL SYSTEM

FILTER REPLACEMENT PROCEDURE

NOTE: While performing filter changes it is recommended to have a towel handy to dry up any residual water that may leak out from the system.

SYSTEM PREPARATION (pre-service check)

1. Turn OFF COLD-WATER source.
2. OPEN Faucet to relieve pressure.

INLINE FILTER REPLACEMENT

1. Remove tubing from the filter you wish to replace by first removing the optional RED locking clip. Then push in the collet on the quick connect fitting while simultaneously pulling on the tubing. (See pg 10)
2. Replace the filter with the new unit taking note of the direction of flow.
3. Fully insert tubing back into fitting until it hits the internal stop.
4. Replace locking clip by sliding it in between collet and fitting. Make sure it is fully seated.
5. Give the tube a gentle tug to ensure proper connection.

HIGH EFFICIENCY REVERSE OSMOSIS MEMBRANE REPLACEMENT

1. Identify and remove the membrane housing from the filter bracket for easier service.
2. Follow the above method for removing the tubing.
3. Unthread the cap from the membrane housing. If overtightened, use a housing wrench.
4. Remove membrane using a pair of pliers.
5. Clean membrane housing with a brush.
6. When installing the new membrane be sure to push the membrane into the housing as far as it will go.

SYSTEM FLUSH (post-service check)

1. Turn ON COLD-WATER source and turn the Diverter Valve ON, directing water to the system.
2. Check all fittings to ensure proper fit.
3. OPEN the system's Faucet to allow water to flush filters. Leave open until water is clear, steady and with no air or odor.
4. Turn OFF COLD-WATER source and CLOSE Faucet when not in use.

CHECK FOR LEAKS DAILY DURING THE FIRST WEEK OF USE AND PERIODICALLY THEREAFTER.



PristineHydro™

WATER REVIVAL SYSTEM

TROUBLESHOOTING

NOTE: Turn OFF the SYSTEM before servicing or inspecting.

PROBLEM	CAUSE	SOLUTIONS
Milky colored water	- Air in the system	* Air in the system is a normal occurrence with initial startup of system. This milky look will disappear during normal use within 1 to 2 weeks
Fishy smell	- New filters	* Slight odor is a normal occurrence with initial startup of system. Slow stream from the system Faucet.
Slow stream from the system Faucet	- System just starting up	* Normally it takes 15-25 minutes to produce 1 gallon. Low water pressure and/or cold temperatures can reduce production rate.
No water production or slow	- Low water pressure - Crimps in tubing - Clogged pre-filters - Fouled High Efficiency Reverse Osmosis Membrane - New System	* Add a booster pump. * Make sure all tubing is straight. * Replace pre-filters. * Replace High Efficiency Reverse Osmosis Membrane. * Wait at least 5 minutes for water to travel through System to Faucet.
Unusual taste or smell	- Coconut Carbon is depleted - Fouled High Efficiency Reverse Osmosis Membrane - Fouled Deionization Cartridge	* Replace Coconut Carbon. * Replace High Efficiency Reverse Osmosis Membrane. * Replace Deionization.
No drain water	- Clogged Auto Shut-Off Valve - Clogged Filter(s)	* Replace Auto Shut-Off Valve. * Replace Filter(s).
Leaks*	- Fittings are not tightened - Loose tubing - Damaged O-Ring	* Tighten fittings as necessary. * Make sure tubing is fully seated in fittings. * Replace the O-Ring.

***LEAKS SHOULD BE TAKEN SERIOUSLY IN ORDER TO PREVENT WATER DAMAGE.**

WATER REVIVAL SYSTEM

CONDITIONS

IMPORTANT - READ THIS FIRST

Please pay attention to the following installation and safety instructions/recommendations:

- Read the installation manual before installing this system.
- Install the system at a location with adequate drainage.
- This water system is for INDOOR use ONLY. To preserve the unit, avoid using excessive water temperatures (HOT or COLD) and protect against sudden temperature changes.
- The system is designed to be installed by and/or under supervision of a professional, licensed installer or plumber.
- Inspect all connections after the installation to make sure NO LEAKS occur.
- Wait and inspect the system AFTER its pressurized.
- MUST install a Pressure Regulator on the system when your water main pressure is over 80 psi.
- Strongly recommended: SHUT OFF the water supply when homeowner/user will not be using the water system for a long period of time.

IMPORTANT

Please contact your insurance carrier before installing your Water Revival System. PristineHydro WILL NOT be responsible for ANY water damage of any kind under any circumstances.

These are our recommendations to avoid water damage.

- Install a PRESSURE REGULATOR/PRESSURE LIMITING VALVE and LEAK DETECTOR SHUTOFF DEVICE to avoid water damage.
- Homeowner/User must properly maintain the water system and replace filters at regular intervals.

ALL O-RINGS SEALS, FITTINGS, FILTER CANISTERS, AND WATER SEAL TAPE WEAR OUT AFTER CERTAIN PERIODS OF TIME. THE LIFETIME OF THESE COMPONENTS ARE SUBJECT TO DIFFERENCES IN WATER QUALITY. THEREFORE, ADEQUATE MAINTENANCE IS NECESSARY AND MANDATORY.

- Please contact a professional, licensed installer or plumber who can implement the above requirements. Our warranty covers replacement or repair of the purchased system only; NO guarantee, warrantee, or other coverage is provided with respect to any damage or loss to property as a result of installation and usage of this product. Please consult with your own insurance carrier for such coverage if desired.

PRODUCT WARRANTY

For further details, please refer to supplier's terms and conditions of sales.

WARNING

DO NOT INSTALL THE SYSTEM WHERE THE WATER IS MICROBIOLOGICALLY UNSAFE OR OF UNKNOWN QUALITY. ADEQUATE DISINFECTION IS REQUIRED BEFORE OR AFTER THE SYSTEM.



PristineHydro™

WATER REVIVAL SYSTEM

LIMITED WARRANTY

All components except the element(s) are warranted to be free of defects in materials or workmanship for a period of one (1) year from the date of purchase. This limited warranty excludes damage resulting from improper care of handling, accidents, modification, unauthorized repairs, normal wear or other causes which are not defects in materials or workmanship.

If there is a covered defect, **PristineHydro™** will repair or replace the product free of charge or issue a refund at its sole discretion. The product is provided "AS IS AND WITH ALL FAULTS," and **PristineHydro** hereby disclaims all other warranties and/or conditions arising out of the use of the product.

PristineHydro shall determine coverage under this warranty only after physical inspection and verification of the unit/defect(s) by **PristineHydro**. Shipping costs for the return of defective systems to **PristineHydro** shall be at the purchaser's expense. **PristineHydro** will ship repaired or replacement systems or parts at **PristineHydro's** expense.

Elements have a one-year pro-rata warranty. If it is established that the element problem is related to material and or workmanship, then the elements will be replaced at no charge in the first month after the date of purchase. A cost of 8 1/3% per month will be charged for each month after the first month. Improper system operation, excessive water temperature (above 100 Deg. F.), failure to prevent chlorine passage into the system, scaling due to water softener or chemical feed operational negligence and general system neglect voids the element warranty.

This warranty covers the cost of materials only. Any labor charges are paid by the system owner. We do not warrant any system or part of a system that has been damaged by neglect, intentional or negligent or improper use, act of nature, fire or vandalism.

PristineHydro™ assumes no warranty liability with respect to defects in any product caused by:

- Customer's unauthorized modification of the product;
- Customer's unauthorized attempt to repair the product;
- Customer's negligent, accidental, or other improper use of the product;
- Customer's installation, operation, or maintenance of the product other than in a manner described in the instruction manual, if applicable;
- Customer's combination of the product with product(s) not supplied by PristineHydro.

WATER REVIVAL SYSTEM

LIMITED WARRANTY

CORRECTION OF DEFECTS BY REPAIR OR REPLACEMENT SHALL CONSTITUTE THE EXCLUSIVE SOLE REMEDY FOR A BREACH OF THIS LIMITED WARRANTY, AND PRISTINEHYDRO WILL NOT BE LIABLE FOR ANY CONSEQUENTIAL DAMAGES, PROPERTY LOSS OR PERSONAL INJURY OR FOR ANY OTHER LOSSES, DAMAGES, OR EXPENSES DIRECTLY OR INDIRECTLY RESULTING FROM THE INSTALLATION OR USE OF PRODUCT, INCLUDING, BUT NOT LIMITED TO WATER DAMAGE. PLEASE CONSULT WITH YOUR OWN INSURANCE CARRIER FOR SUCH COVERAGE IF DESIRED. THE ABOVE WARRANTY SUPERSEDES AND IS IN LIEU OF ALL OTHER WARRANTIES, EXPRESS OR IMPLIED, AND ALL OTHER OBLIGATIONS OR LIABILITIES OF PRISTINEHYDRO, INCLUDING ANY IMPLIED WARRANTIES OF MERCHANTABILITY AND FITNESS FOR A PARTICULAR PURPOSE. NO AGENT DISTRIBUTOR, RETAILER, OR OTHER PARTY IS AUTHORIZED TO MAKE ANY WARRANTIES ON BEHALF OF PRISTINEHYDRO OR TO ASSUME FOR PRISTINEHYDRO ANY OTHER LIABILITY IN CONNECTION WITH ANY PRISTINEHYDRO PRODUCT.

The construction, validity, and performance of this agreement between PristineHydro and customer (purchaser and/or owner of the product) shall be governed by the laws of the State of California, United States of America, without reference to its choice of law rules. Customer expressly submits and consents to the jurisdiction and venue of the State or Federal courts located in Orange County, California, for the trial of any lawsuit arising out of the contract for sale. Any action for the breach of the contract for sale must be commenced within one (1) year after the cause of action has accrued.

FORCE MAJEURE - PristineHydro shall not be liable for any default or delay attributable to any cause, circumstance, or contingency beyond its control or the control of its suppliers or manufacturers which prevents or impedes manufacture, supply, or delivery by PristineHydro. Such causes, circumstances, and contingencies shall include, but not be limited to: acts of God; governmental acts, decrees or restrictions; accidents; wars, riots, or civil commotion; fire; strikes, lockouts, or other labor problems; restraints affecting shipment or credit; non arrival or delay of carriers; inadequate or reduced supply or excessive cost of suitable raw materials, transportation or production facilities; and any other causes, circumstances, or contingencies affecting PristineHydro, its suppliers, or manufacturers as to manufacture, supply, or delivery. In the event of such default



PristineHydro™

WATER REVIVAL SYSTEM

LIMITED WARRANTY

or delay, the date for shipment shall be extended correspondingly. PristineHydro may make delivery on an equitable basis with reference to all its customers.

For service assistance or resolution of a service problem,
or for product information or operation, please visit:

WWW.LIVEPRISTINE.COM

PristineHydro™



LivePristine
WWW.LIVEPRISTINE.COM