



**MAJOR
FITNESS**



The power cage includes four packages , please confirm before installation

Spirit B52



Website:
major-lutie.com

Email:
after-sale@major-lutie.com

Website:

major-lutie.com

After-sales service:

after-sale@major-lutie.com



Installation Video



SERVICE

For the **best service**, please have the following information ready when requesting for service:

- **Buyer Full Name**
- **Order Number**
- **Part Number**
- **Part Picture**
- **Model Number**
- **Phone Number**

If you have any questions, receive a damaged part or need additional service support, please contact our customer service department via the following methods:

Please Email:

after-sale@major-lutie.com

Response Time: 1-2 Business Days

Emailing us with the information above will be the best method to receive a response.

Toll-Free:

800-276-8577

(9:00 AM - 4:00 PM EST, Monday - Friday)

Visit Website:

major-lutie.com



GUIDEILNES

Before using this equipment, it is strongly recommended that you consult your physician whether this fitness equipment is applicable to you. Please do not use this machine if you have the following conditions or diseases:

- **Heart Disorders**
- **Recent Stroke or Transient Ischemic Attack**
- **Extreme Obesity**
- **Pregnancy**
- **Bone Weaknesses**
- **Spinal Injury**
- **High Blood Pressure or Hypertension**
- **Hiatus Hernia or Ventral Hernia**
- **In a State of Intoxication or Fatigue**
- **Other diseases that are NOT recommended by doctors for exercise**

This equipment is designed and intended for home and consumer use only, not for commercial use.



Please read all instructions carefully before assembling or operating this product.

This workout equipment is designed and built for optimum safety. However, certain precautions apply whenever you operate this exercise equipment. Be sure to read the entire manual before assembling and operating this equipment. Also, note the following safety instructions:

1. Two people are recommended for the installation of this product instead of one.
2. If you feel dizzy, or other abnormal sensations at any time while operating this device, please stop using the product or exercise and contact your physician as soon as possible.
3. Make sure your equipment is correctly assembled before you use it. Be sure all the screws, nuts, and bolts are tightened prior to use.
4. If this equipment or parts are damaged, do not use it again to exercise.
5. Please do not eat within one hour before using the machine.
6. This product should be placed on a flat surface when using. A mat or other covering material on the ground is recommended.
7. Keep children and pets away from this equipment at all times.
8. It is recommended to wear tight training clothes, tie your hair up, preferably in a ponytail, and remove your jewelry when using this product to avoid unexpected hazards.
9. It is recommended that novice or teenagers should be accompanied by a trainer or parents to use our products, and children under 12 years old are not recommended to use this fitness equipment.
10. The users of this product should keep their weight within 220lb/100kg.



PREPARATION

1. Tools for assembly:

General tools you may need for the assembling this strength equipment:

- **Electric screwdrivers**
- **Hexagon wrench sets**
- **Wrench sets and adjustable wrenches**
- **Rubber Hammer**
- **Lubricant**

2. Insert bolts into the frame as illustrated in the drawing of each of the steps.

3. **Hand-tighten the bolts and nuts during assembly.** Tighten all the hardware once the entire unit has been completely assembled.

4. With the proper assistance, the right tools, and strictly following the assembly steps, and given enough time.











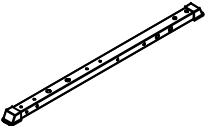
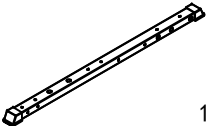
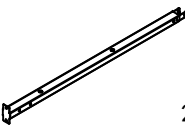
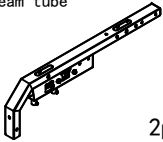
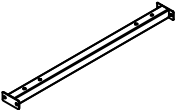
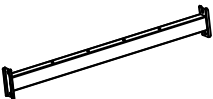
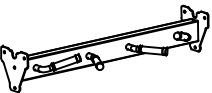
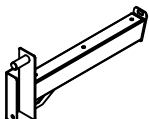
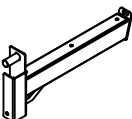
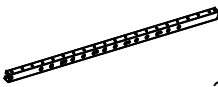
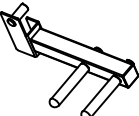
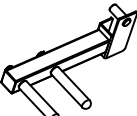
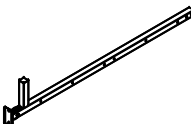

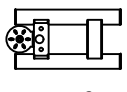

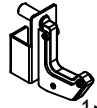

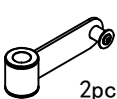
5. Thoroughly read each step before proceeding to assemble the parts of that step.

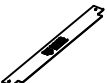
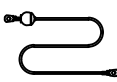
6. To help make it easier for you to assemble the device, we have noted the required hardware in the every steps.

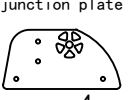
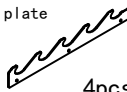
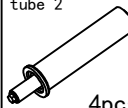
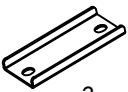

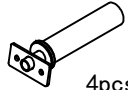

7. When the equipment is fully assembled check all the functions for correct operation. Consult the manual if you experience any issues, or for further help please contact our service department.

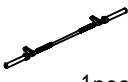
8. Please regularly check if the screws are loose, and if they are, tighten them quickly.



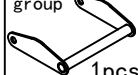

PARTS LIST

A. Left bottom duct  1pcs	B. Right bottom duct  1pcs	C. Rear pillar tube  2pcs			
D. Top beam tube  2pcs	E. Bottom connecting pipe  1pcs	F. Upper connecting pipe  1pcs			
G. Pull-up tube  1pcs	H1. Left transverse branch  1pcs	H2. Right transverse branch  1pcs			
I. Front pillar tube  2pcs	J1. Left handlebar tube  1pcs	J2. Right handlebar tube  1pcs			
K. Middle column tube group  2pcs	L. Perforated large round iron sheet group  2pcs	M. Weight frame  2pcs	N1. Left hook  1pcs	N2. Right hook  1pcs	
O. Reinforce  2pcs	P. Guide rod  4pcs	Q. Barbell bar limit tube set  2pcs	R. Carriage  2pcs	S. 72 Casing set  2pcs	T. Acrylic plate  1pcs
U. Cable  2pcs	V. Guide pillar  2pcs	W. Down junction plate  4pcs	X. Barbell rod adjustment plate  4pcs	Y. Load bearing tube 2  4pcs	Z. Connect U  2pcs
AB. Upper junction plate  2pcs	AC. Load bearing tube 1  4pcs	AD. Connecting piece  4pcs	AE. Lifting sliding sleeve  2pcs	AF. Rotating sleeve  2pcs	AG. Barbell bar group  1pcs



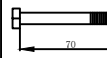
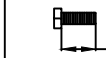

PARTS LIST

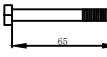
A-1. Gun barrel frame  1pcs	B-1. Rear pillar tube  1pcs	B-2. Pedal  1pcs	B-3. Pedal support plate group  1pcs	D-1. Nylon slip  4pcs	W-1. Nylon slip  2pcs
--	--	---	---	--	--

HARDWARE LIST

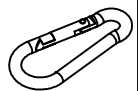

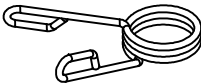
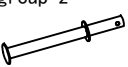
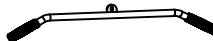
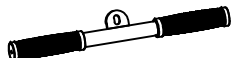
1. Hexagon bolt (M10x90L)  32pcs	2. Hexagon bolt (M10x80L)  4pcs	3. Hexagon bolt (M10x70L)  24pcs	4. Hexagon bolt (M10x20L)  10pcs	5. Flat gasket $\phi 10$  162pcs	6. Lock nut M10  78pcs
7. Hexagon bolt (M10x65L)  14pcs					

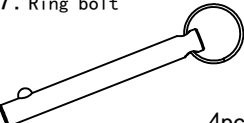
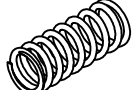
ACCESSORIES LIST

8. Shock pad  6pcs	9. Buckle  2pcs	10. Handle  2pcs	11. $\phi 50$ butterfly clip  4pcs	12. Part group 2  4pcs
13. Lat pull-down bar  1pcs	14. Cable bar  1pcs	15. V bar  1pcs		
16. Sheep eye open screw hook  4pcs	17. Ring bolt  4pcs	18. Butterfly clip  2pcs		

Do not tighten all bolts until all installations are complete.

STEP 3.

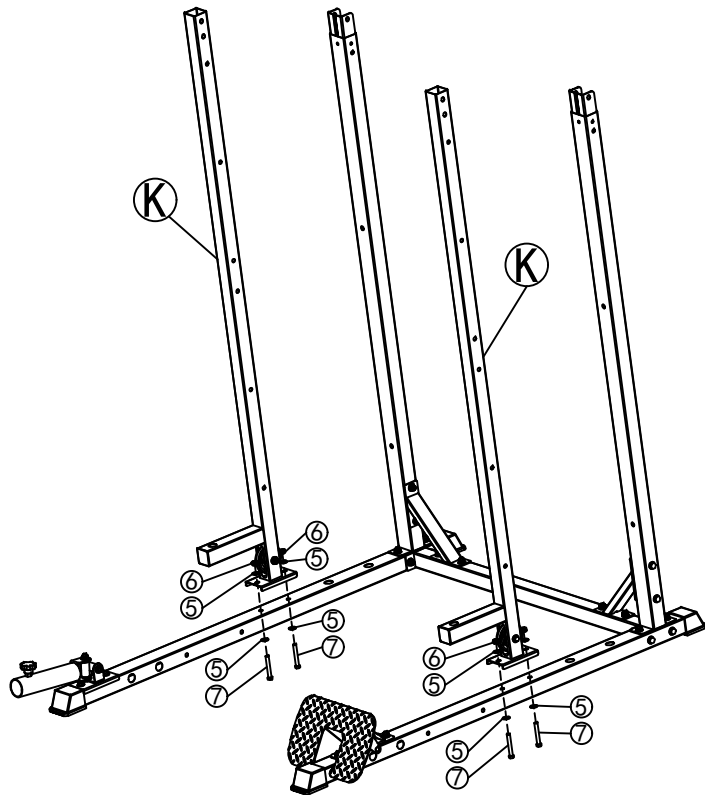

7. Hexagon bolt (M10x65L)  4pcs	5. Flat gasket ϕ 10  8pcs	6. Locek nut M10  4pcs		
---	---	---	--	--

NOTE: Except for pre-installing the hardware you need



Do not tighten all bolts until all installations are complete.

STEP 4.

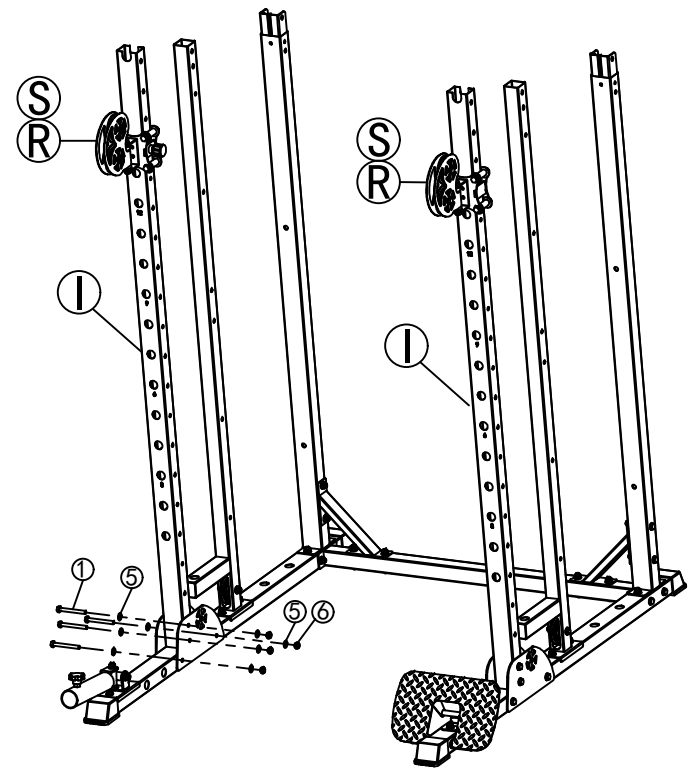

1. Hexagon bolt (M10x90L)  8pcs	5. Flat gasket ϕ 10  16pcs	6. Lock nut M10  8pcs		
---	--	--	--	--

NOTE: Except for pre-installing the hardware you need

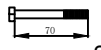

Do not tighten all bolts until all installations are complete.

STEP 5.

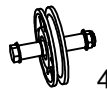

3. Hexagon bolt (M10x70L)  8pcs	5. Flat gasket $\phi 10$  16pcs	6. Locek nut M10  8pcs	D-1. Nylon slip  4pcs
--	--	---	--

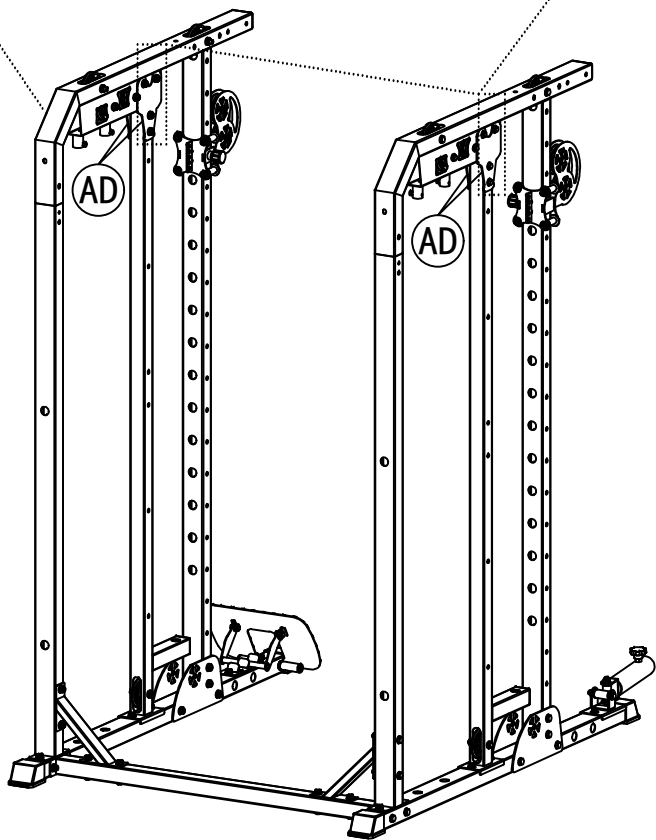
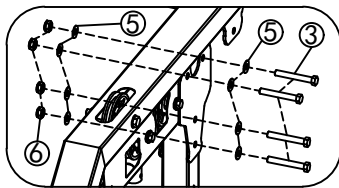
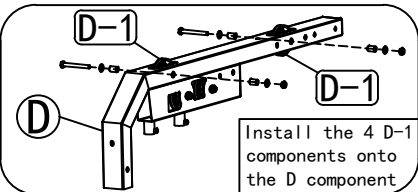
NOTE: Except for pre-installing the hardware you need



Do not tighten all bolts until all installations are complete.

STEP 6.

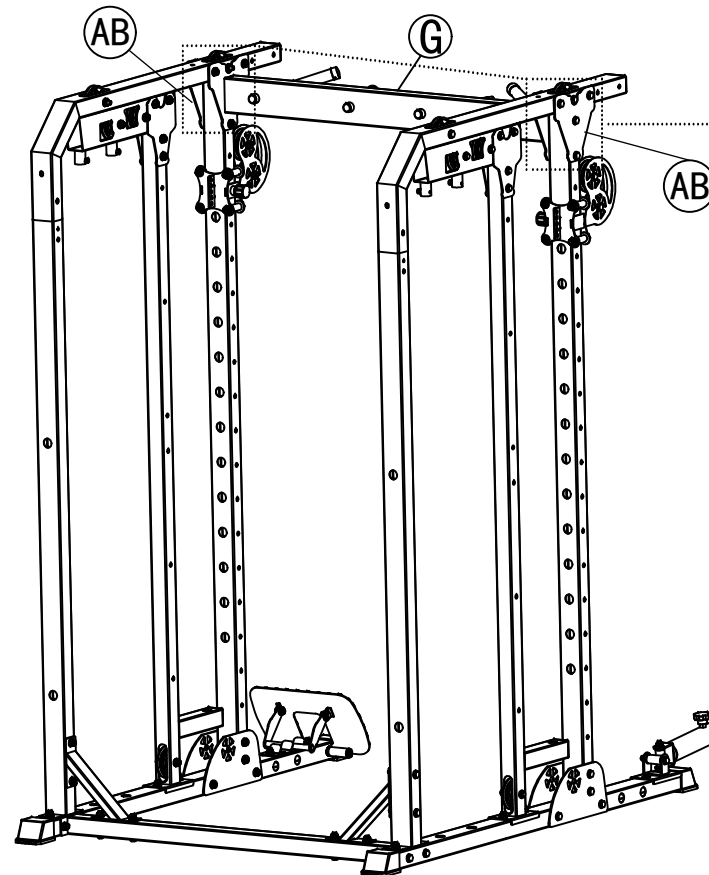
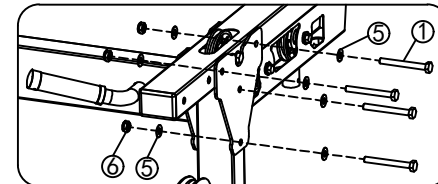

1. Hexagon bolt (M10x90L)  8pcs	5. Flat gasket $\phi 10$  14pcs	6. Locek nut M10  6pcs	
--	--	---	--

NOTE: Except for pre-installing the hardware you need



Do not tighten all bolts until all installations are complete.

STEP 7.

1. Hexagon bolt (M10x90L)  4pcs	5. Flat gasket $\phi 10$  8pcs	6. Lock nut M10  4pcs		
---	---	--	--	--

NOTE: Except for pre-installing the hardware you need

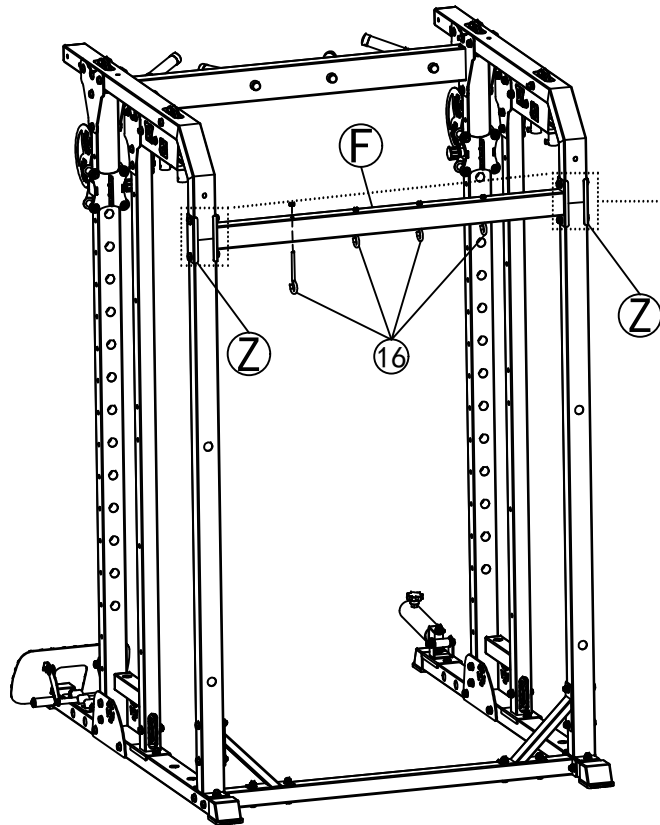
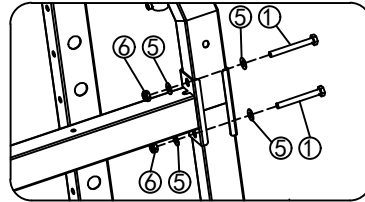

Do not tighten all bolts until all installations are complete.

STEP 8.

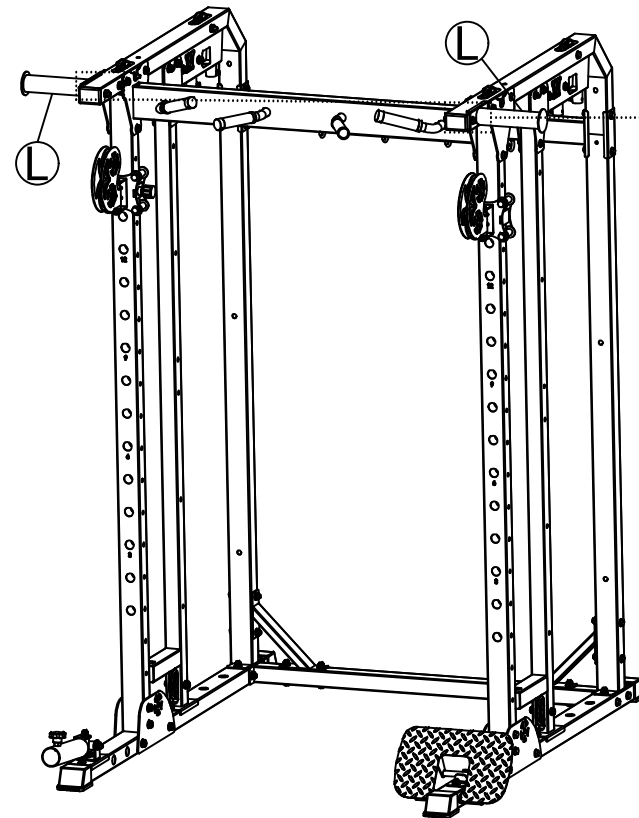
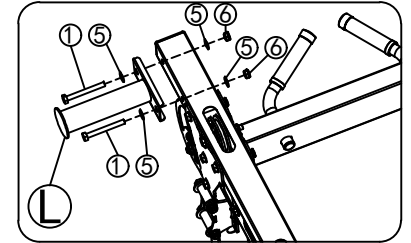

1. Hexagon bolt (M10x90L)  4pcs	5. Flat gasket $\phi 10$  8pcs	6. Lock nut M10  4pcs		
---	---	--	--	--

NOTE: Except for pre-installing the hardware you need



Do not tighten all bolts until all installations are complete.

STEP 9.

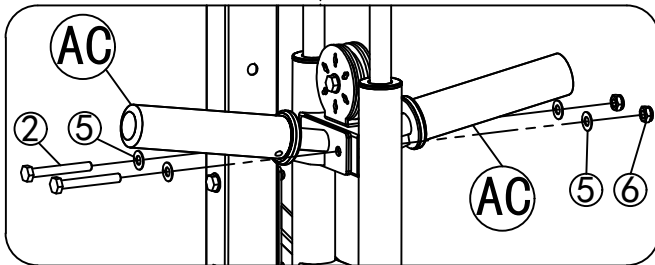
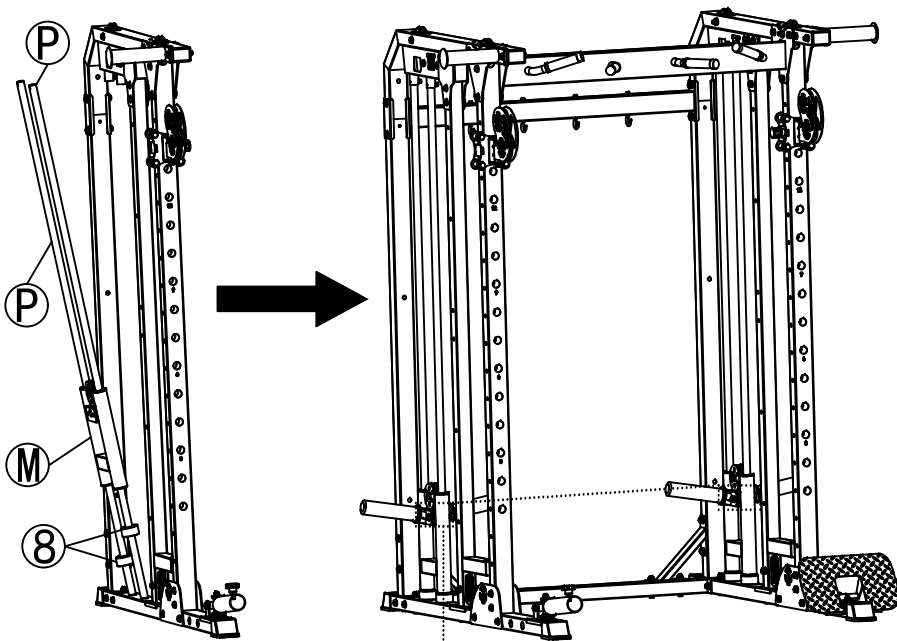

2. Hexagon bolt (M10x80L)  4pcs	5. Flat gasket $\phi 10$  8pcs	6. Lock nut M10  4pcs		
---	--	---	--	--

NOTE: Except for pre-installing the hardware you need



Do not tighten all bolts until all installations are complete.

STEP 10.

3. Hexagon bolt (M10x70L)  12pcs	5. Flat gasket $\phi 10$  24pcs	6. Lock nut M10  12pcs		
--	---	--	--	--

NOTE: Except for pre-installing the hardware you need

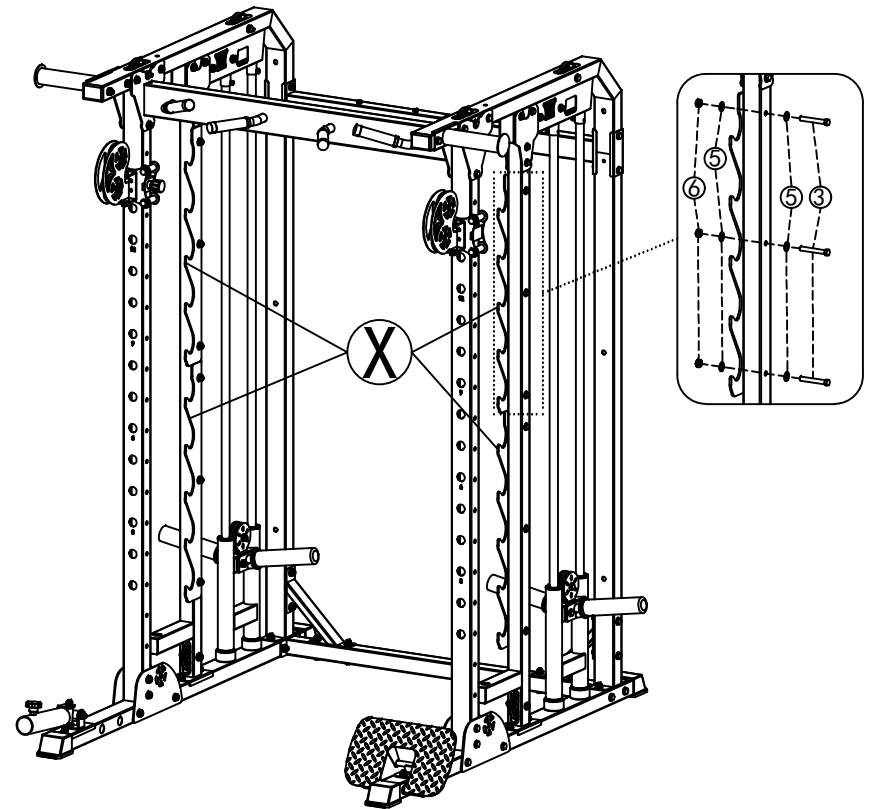

Do not tighten all bolts until all installations are complete.

STEP 11.

3. Hexagon bolt
(M10x70L)

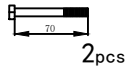

2pcs

5. Flat gasket $\phi 10$



2pcs

NOTE: Except for pre-installing the hardware you need

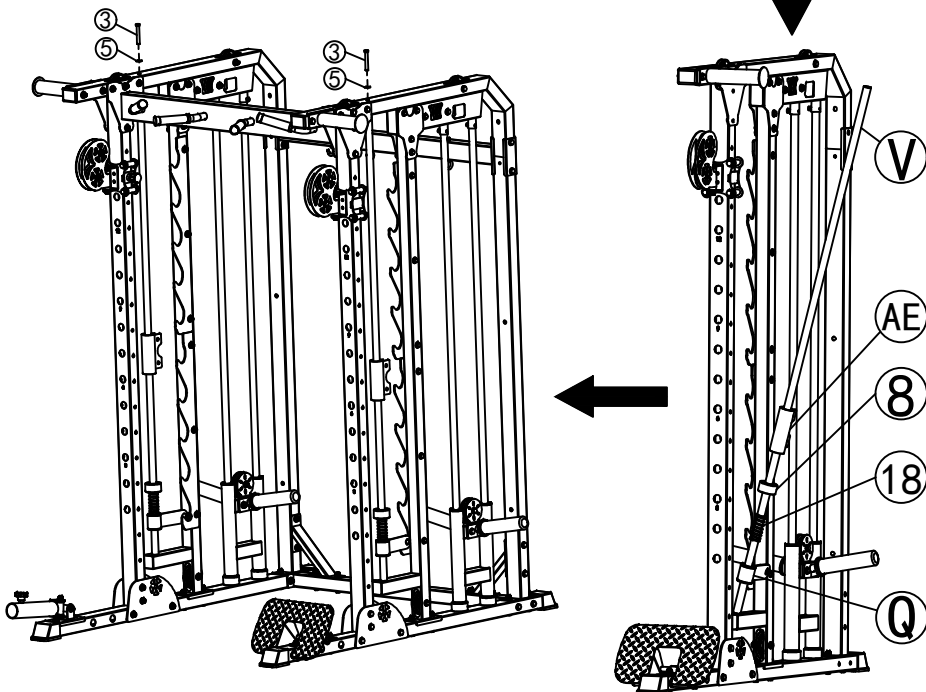
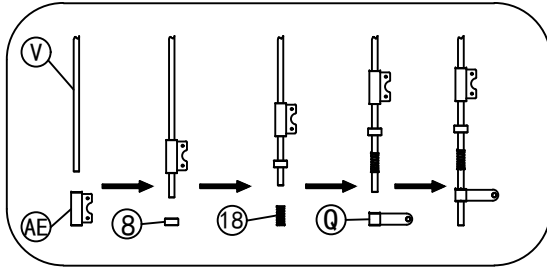

Do not tighten all bolts until all installations are complete.

STEP 12.

NOTE: Except for pre-installing the hardware you need

As shown in the figure, first hang the barbell bar on component X, use a wrench to loosen the pre locked screw on the barbell bar: M10 * 20L, remove the barbell sleeve from the barbell bar, then install AF onto the barbell bar, and then install the barbell sleeve onto the barbell bar, locking the screw.

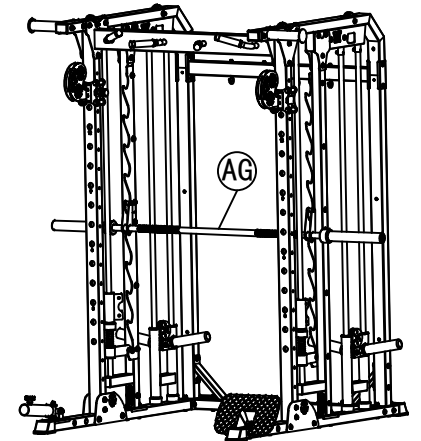

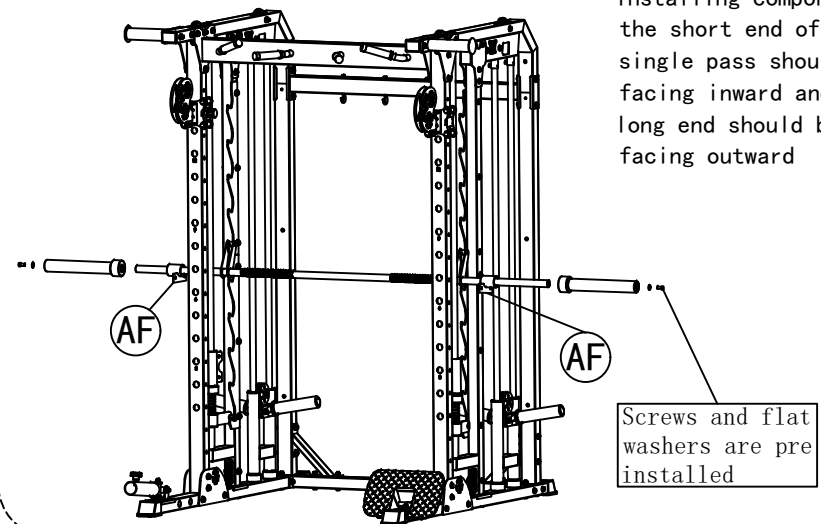

Attention: When installing component AF, the short end of the single pass should be facing inward and the long end should be facing outward



Do not tighten all bolts until all installations are complete.

STEP 13.

4. Hexagon bolt (M10x20L)  4pcs	5. Flat gasket ϕ 10  8pcs	6. Lock nut M10  4pcs		
---	---	--	--	--

NOTE: Except for pre-installing the hardware you need

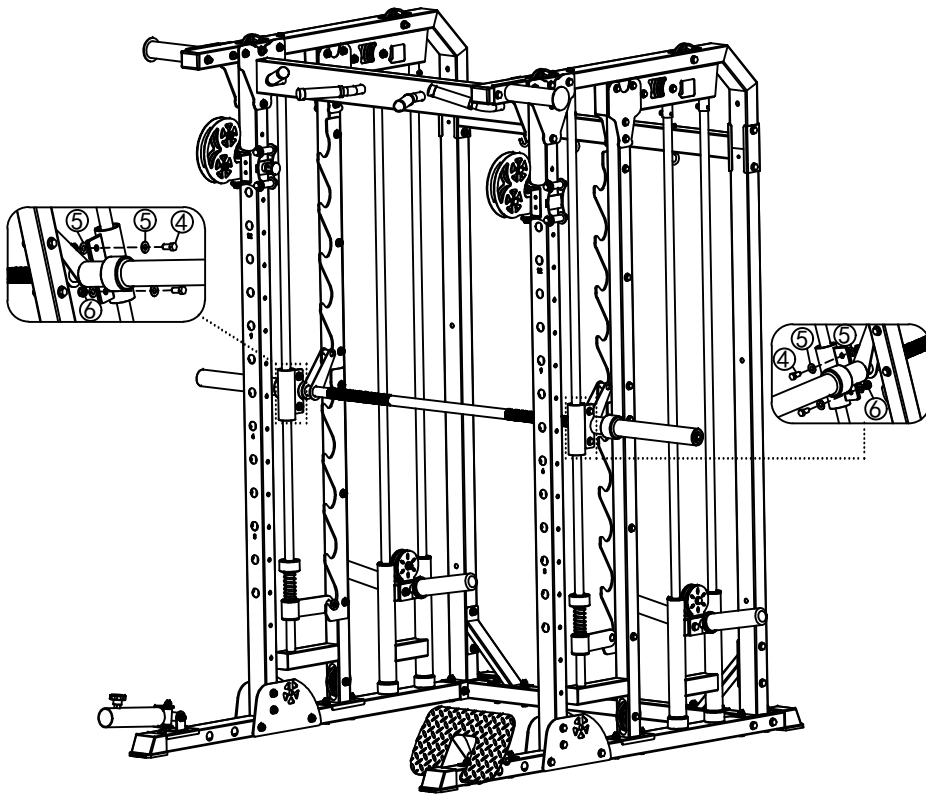

Do not tighten all bolts until all installations are complete.

STEP 14.

--	--	--	--	--

NOTE: Except for pre-installing the hardware you need

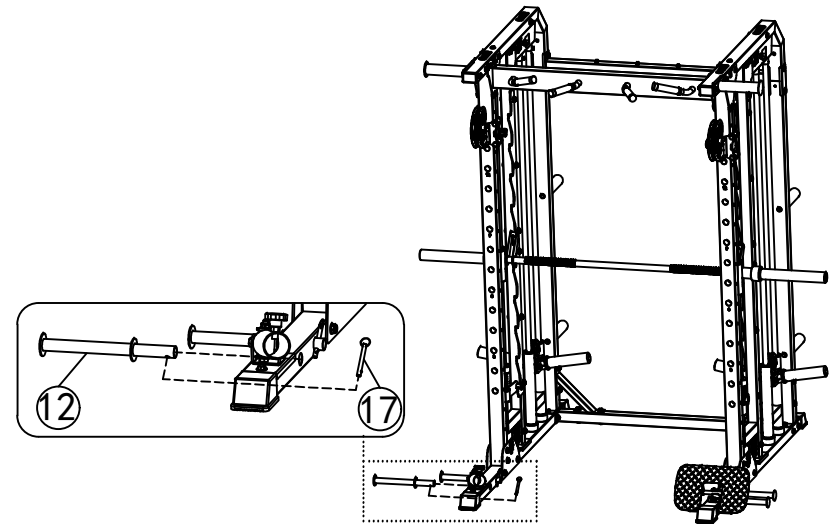
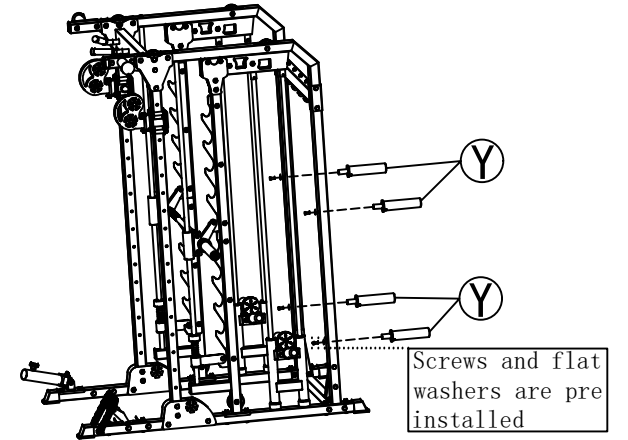

Do not tighten all bolts until all installations are complete.

STEP 15.





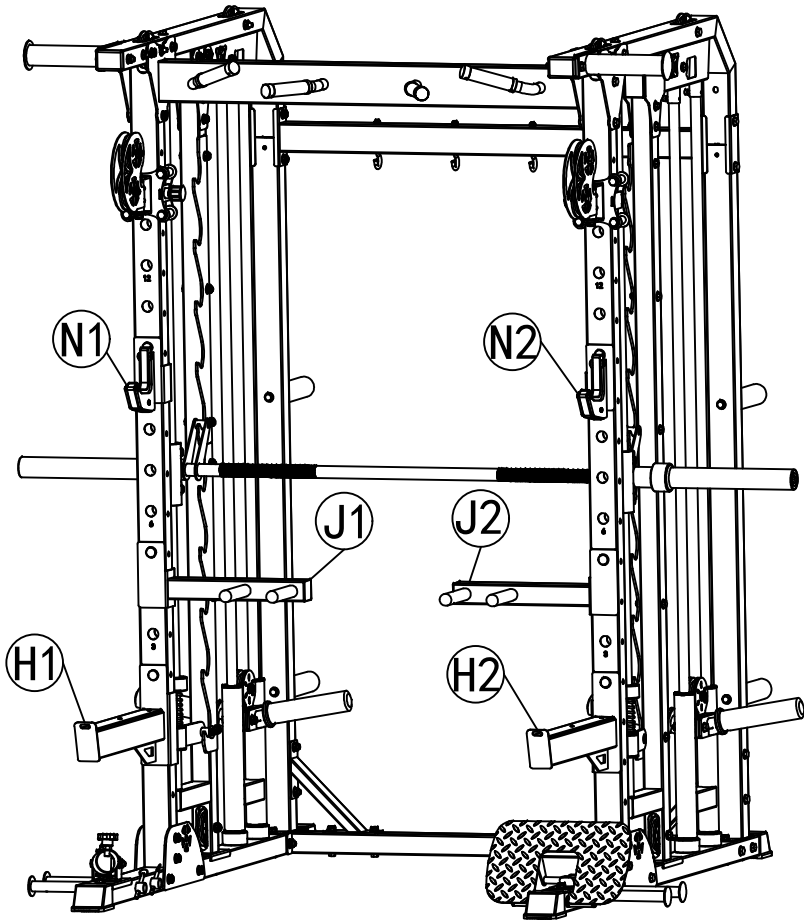

NOTE: Except for pre-installing the hardware you need



Do not tighten all bolts until all installations are complete.

STEP 16.

4. Hexagon bolt (M10x20L)  2 pcs	5. Flat gasket $\phi 10$  4 pcs	6. Lock nut M10  2 pcs	W-1. Nylon slip  2 pcs
---	--	---	---

NOTE: Except for pre-installing the hardware you need

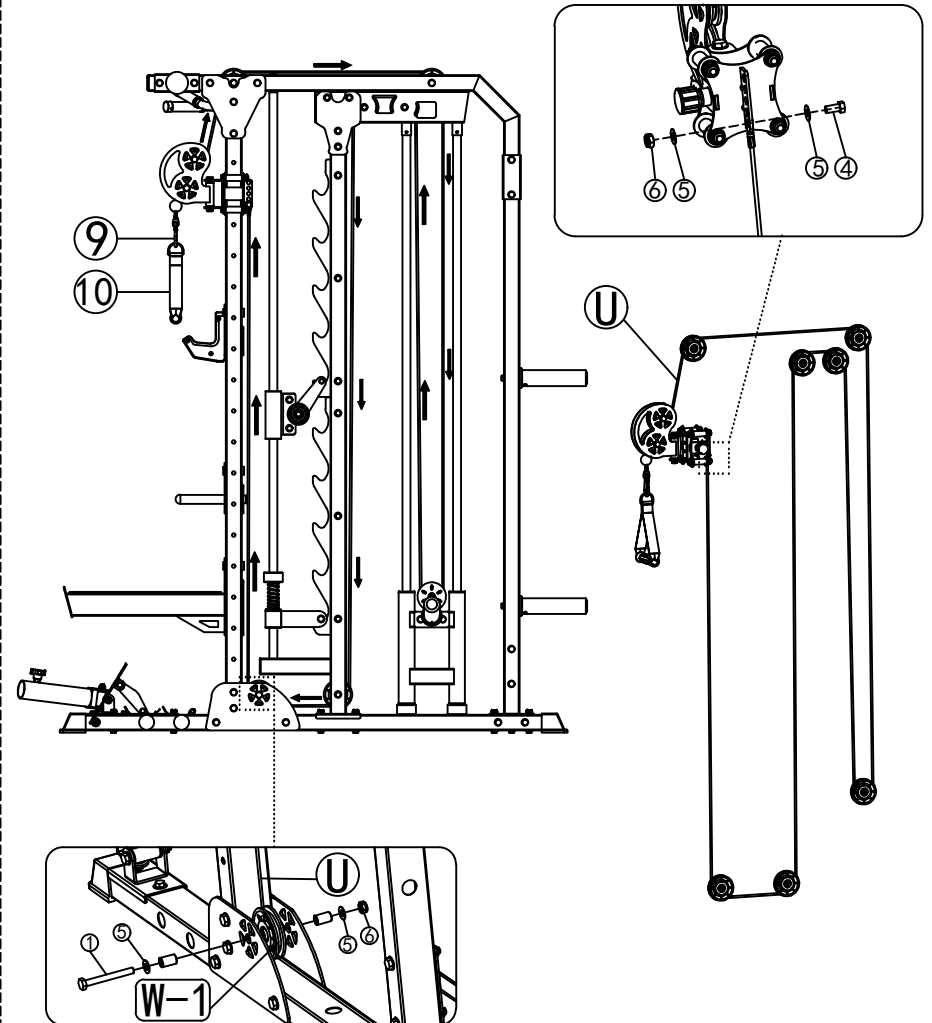

Do not tighten all bolts until all installations are complete.

STEP 17.

3. Hexagon bolt
(M10x70L)

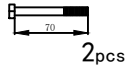

2pcs

5. Flat gasket $\phi 10$



4pcs

6. Lock nut M10



2pcs

NOTE: Except for pre-installing the hardware you need

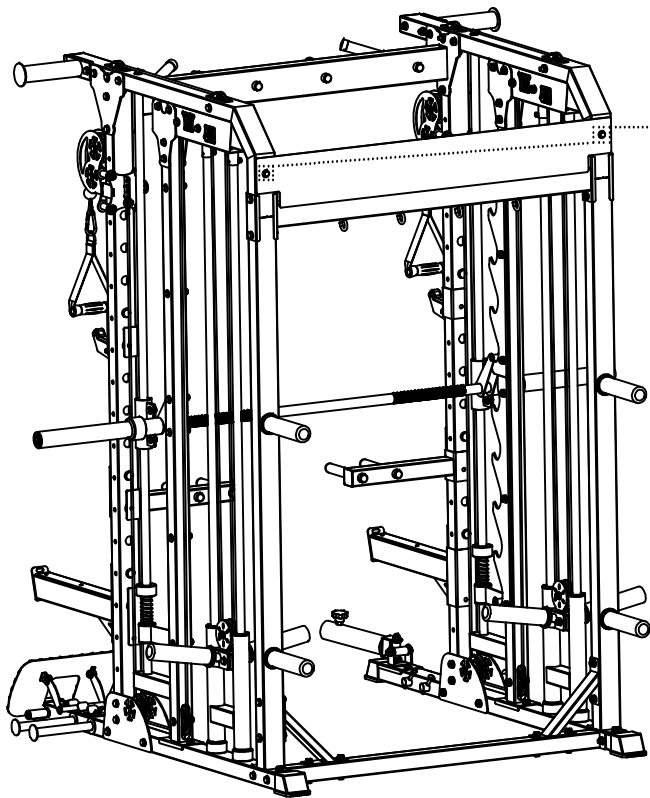
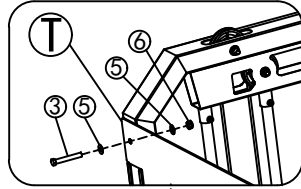

Please regularly check whether the screws are tight

