

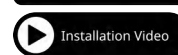

MAJOR
LUTIE FITNESS

MULTI-FUNCTIONAL SMITH MACHINE WITH CABLE MACHINE

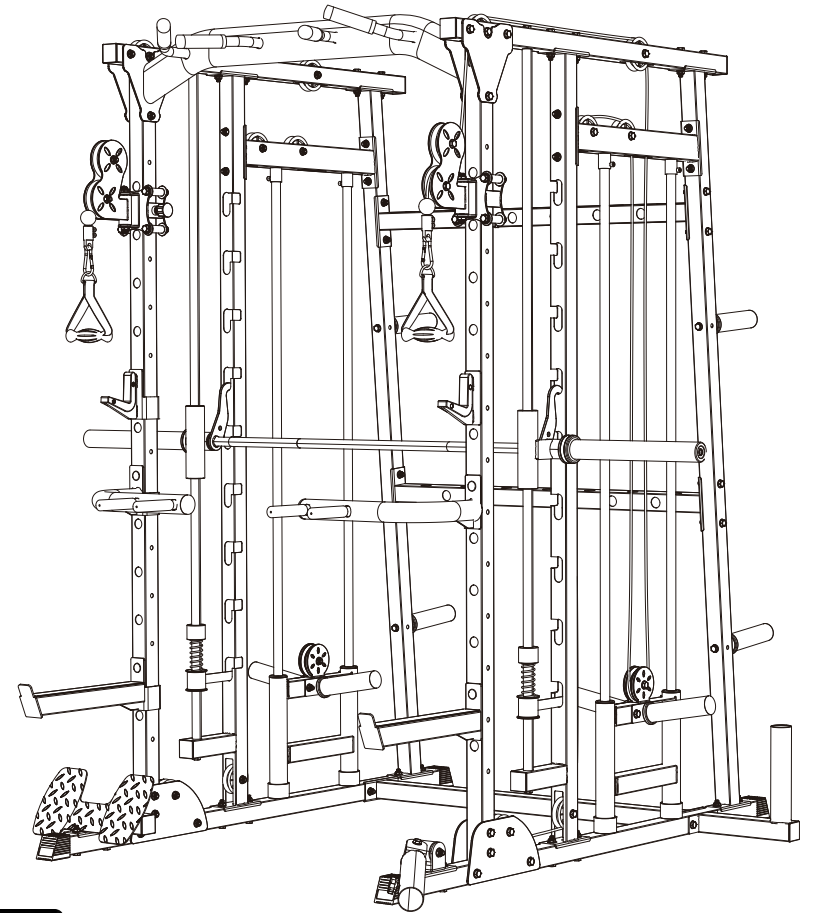

Website:
kjbfitness.com.au
major-lutie.com

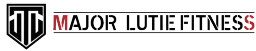

SERVICE

For the **best service**, please have the following information ready when requesting for service:

- **Buyer Full Name**
- **Oder Number**
- **Part Number**
- **Part Picture**
- **Model Number**
- **Phone Number**

If you have any questions, receive a damaged part or need additional service support, please contact our customer service department via the following methods:

Please Email:

after-sale@major-lutie.com

Response Time: 1-2 Business Days

Emailing us with the information above will be the best method to receive a response.

Toll-Free:

800-276-8577

(9:00 AM - 4:00 PM EST, Monday - Friday)

Visit Website:

<https://www.major-lutie.com/>

Please keep the original packaging of our products, if you are not sure if there is a return request. We no longer provide new boxes on returns, thanks for your understanding in advance.

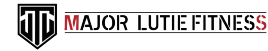

GUIDEILNES

Before using this equipment, it is strongly recommended that you consult your physician whether this fitness equipment is applicable to you. Please do not use this machine if you have the following conditions or diseases:

- **Heart Disorders**
- **Recent Stroke or Transient Ischemic Attack**
- **Extreme Obesity**
- **Pregnancy**
- **Bone Weaknesses**
- **Spinal Injury**
- **High Blood Pressure or Hypertension**
- **Hiatus Hernia or Ventral Hernia**
- **In a State of Intoxication or Fatigue**
- **Other diseases that are NOT recommended by doctors for exercise**

This equipment is designed and intended for home and consumer use only, not for commercial use.

Please read all instructions carefully before assembling or operating this product.

This workout equipment is designed and built for optimum safety. However, certain precautions apply whenever you operate this exercise equipment. Be sure to read the entire manual before assembling and operating this equipment. Also, note the following safety instructions:

1. Two people are recommended for the installation of this product instead of one.
2. If you feel dizzy, or other abnormal sensations at any time while operating this device, please stop using the product or exercise and contact your physician as soon as possible.
3. Make sure your equipment is correctly assembled before you use it. Be sure all the screws, nuts, and bolts are tightened prior to use.
4. If this equipment or parts are damaged, do not use it again to exercise.
5. Please do not eat within one hour before using the machine.
6. This product should be placed on a flat surface when using. A mat or other covering material on the ground is recommended.
7. Keep children and pets away from this equipment at all times.
8. It is recommended to wear tight training clothes, tie your hair up, preferably in a ponytail, and remove your jewelry when using this product to avoid unexpected hazards.
9. It is recommended that novice or teenagers should be accompanied by a trainer or parents to use our products, and children under 12 years old are not recommended to use this fitness equipment.
10. The users of this product should keep their weight within 300lb/150kg.

PREPARATION

1. Tools for assembly:

General tools you may need for the assembling this strength equipment:

- **Electric screwdrivers**
- **Hexagon wrench sets**
- **Wrench sets and adjustable wrenches**
- **Rubber Hammer**
- **Lubricant**

2. Insert bolts into the frame as illustrated in the drawing of each of the steps.

3. **Hand-tighten the bolts and nuts during assembly.** Tighten all the hardware once the entire unit has been completely assembled.

















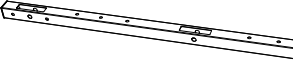
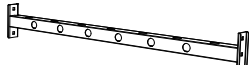
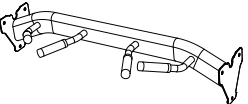



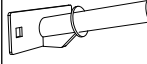
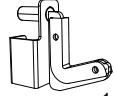

4. With the proper assistance, the right tools, and strictly following the assembly steps, and given enough time.

5. Thoroughly read each step before proceeding to assemble the parts of that step.

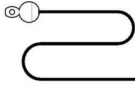
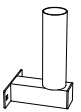
6. To help make it easier for you to assemble the device, we have noted the required hardware in the every steps.



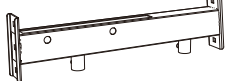
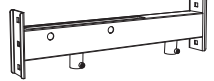
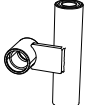
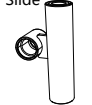

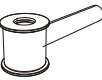
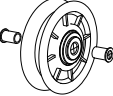

7. When the equipment is fully assembled check all the functions for correct operation. Consult the manual if you experience any issues, or for further help please contact our service department.

PARTS LIST









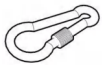

A. Left-right underframe  2pcs	B. Rear underframe  1pc	C1. Left-Front column  1pc	C2. Right-Front column  1pc
C3. Left-Rear pillar  1pc	C4. Right-Rear pillar  1pc	D. Left-right upper frame  2pcs	
E. Rear cross frame  2pcs		F. Front upper frame  1pc	
G. Weight-bearing guide rod  4pcs	H1. Weight-bearing frame  2pcs	I1. Left-carriage  1pc	I2. Right-carriage  1pc
J1. Left-carriage  1pc	J2. Right-carriage  1pc	H2. Weight-bearing  4pcs	K1. Left-Pothead  1pc
M1. Upper unction plate  2pcs	M2. Down junction plate  4pcs	N1. Gun barrel frame  1pc	N2. Gun barrel frame  1pc
P. Cable  2pcs	Q. Rest stand  1pc	R1. Left-Barbell bracket  1pc	R2. Right-Barbell bracket  1pc
S2. Right-Center pillar  1pc	T1. Left-Cross beam frame  1pc		T2. Right-Cross beam frame  1pc
U1. Left-Linear Slide  1pc	U2. Right-Linear Slide  1pc	V. Barbell rod  1pc	W. Barbell sleeve  2pcs

X. Bar bell guide rod  2pcs	Y. Fender bracket  2pcs	Z. Nylon Slip  12pcs	
We have prepared two spare pulleys for you, so if any pulley is broken, you can use the spare pulley instead.			

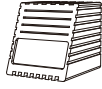
HARDWARE LIST

1. Hexagon bolt (M10x70)  56pcs	2. Hexagon bolt (M10x80)  6pcs	3. Hexagon bolt (M10x25)  2pcs	4. Hexagon bolt (M12x70)  2pcs	5. Flat gasket∅10  140pcs	6. Flat gasket∅12  4pcs
7. Loek nut M10  63pcs					

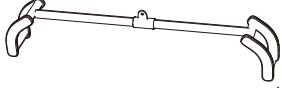
ACCESSORIES LIST

8. Shock pad  6pcs	9. Stand of Barbell Slice  8pcs	10. Buckle  2pcs	11. Handle  2pcs	12. Spring  2pcs	13. Rubber Cover  4pcs
14. DUMBBELL PIECE STORAGE ROD  4pcs	15. V BAR  1pc	16. CABLE BAR  1pc	17. V-Shaped Bar (Red)  1pc	18. Wide Grip LAT Bar (Red)  1pc	
19. Ez Curl (Red)  1pc	20. LAT PULL-DOWN BAR  1pc				

Do not tighten all bolts until all installations are complete.

STEP 1.

1. Hexagon bolt (M10x70)



8pcs

5. Flat gasket $\varnothing 10$



16pcs

7. Loek nut M10



8pcs

Note: Except for pre-installing the hardware you need

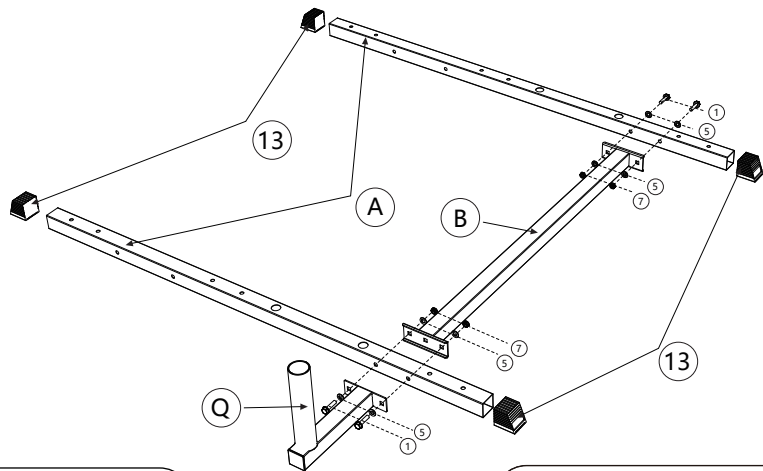

O. Pedal

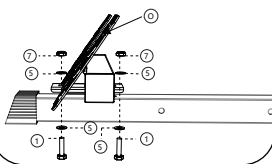

N1. Gun barrel frame

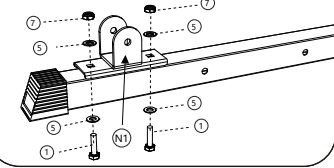

N2. Gun barrel frame

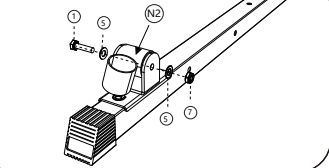

N3. Gun barrel frame

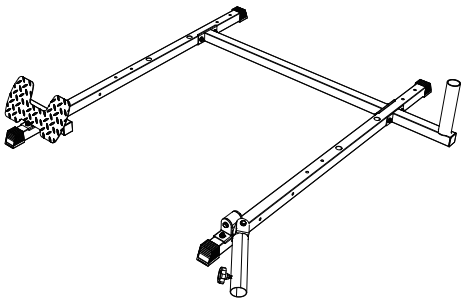
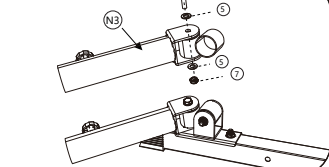

Do not tighten all bolts until all installations are complete.

STEP 2.

Note: Except for pre-installing the hardware you need

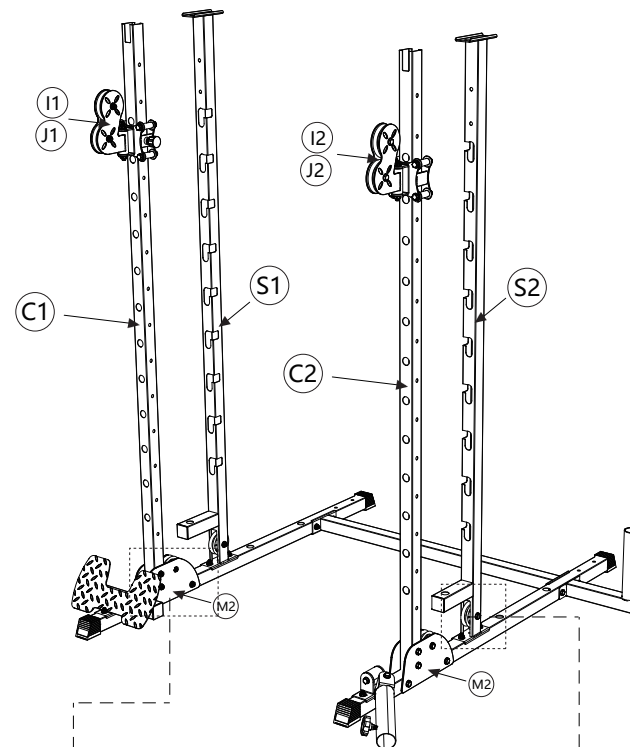

1. Hexagon bolt (M10x70)



14pcs

5. Flat gasket $\varnothing 10$



28pcs

7. Loek nut M10



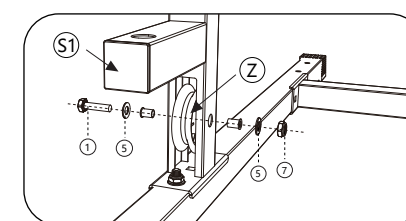
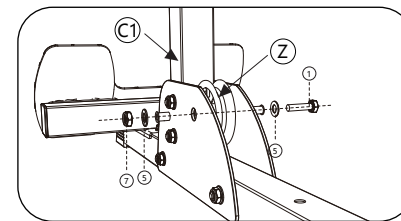
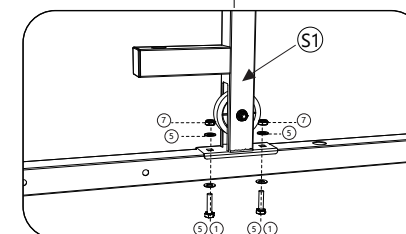
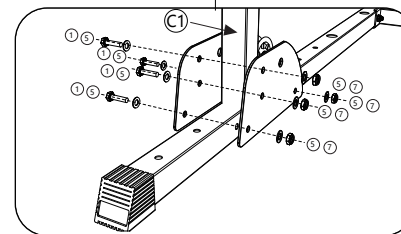

14pcs



Do not tighten all bolts until all installations are complete.

STEP 3.

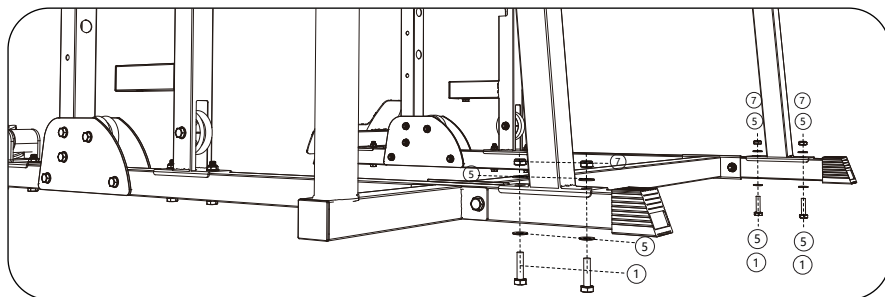
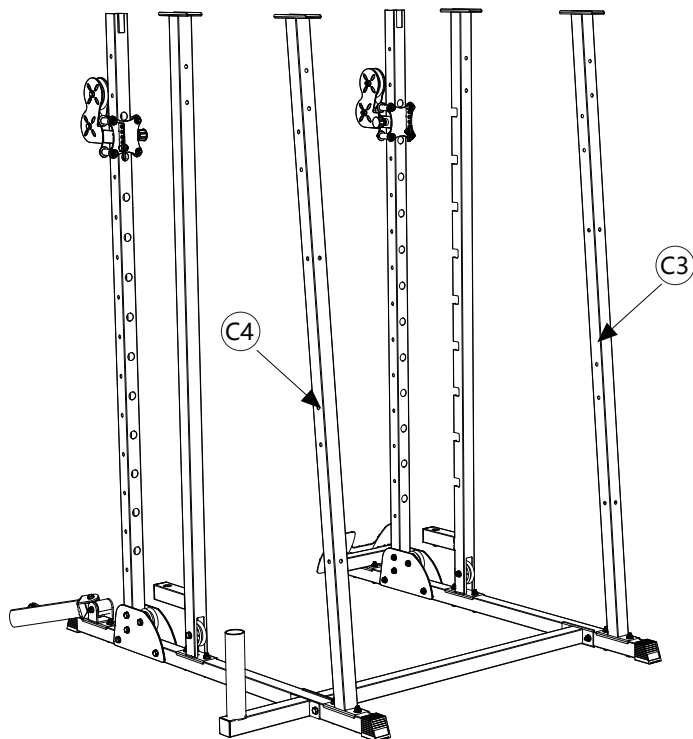

<p>1. Hexagon bolt (M10x70)</p>  <p>4pcs</p>	<p>5. Flat gasket $\varnothing 10$</p>  <p>8pcs</p>	<p>7. Loek nut M10</p>  <p>4pcs</p>		
--	--	---	--	--

Note: Except for pre-installing the hardware you need



Do not tighten all bolts until all installations are complete.

STEP 4.

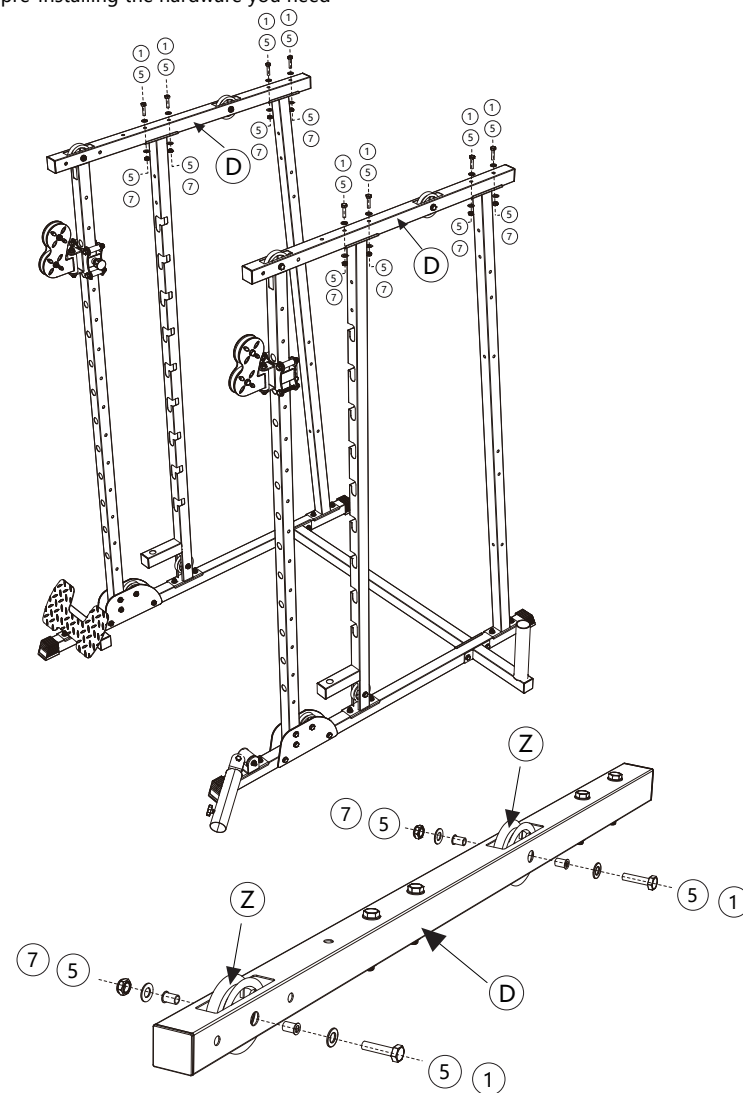

<p>1. Hexagon bolt (M10x70)</p>  <p>8pcs</p>	<p>5. Flat gasket $\varnothing 10$</p>  <p>16pcs</p>	<p>7. Loek nut M10</p>  <p>8pcs</p>		
--	---	---	--	--

Note: Except for pre-installing the hardware you need



Do not tighten all bolts until all installations are complete.

STEP 5.

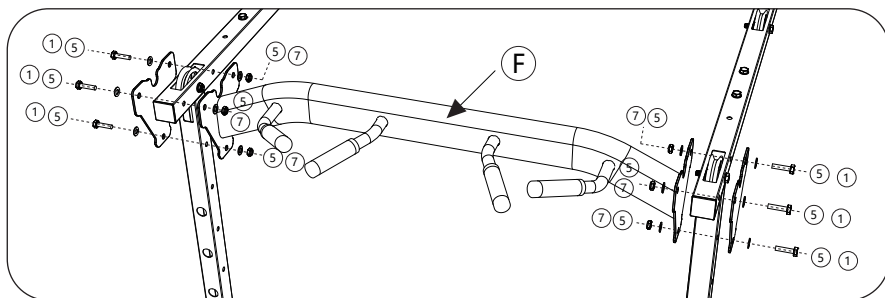
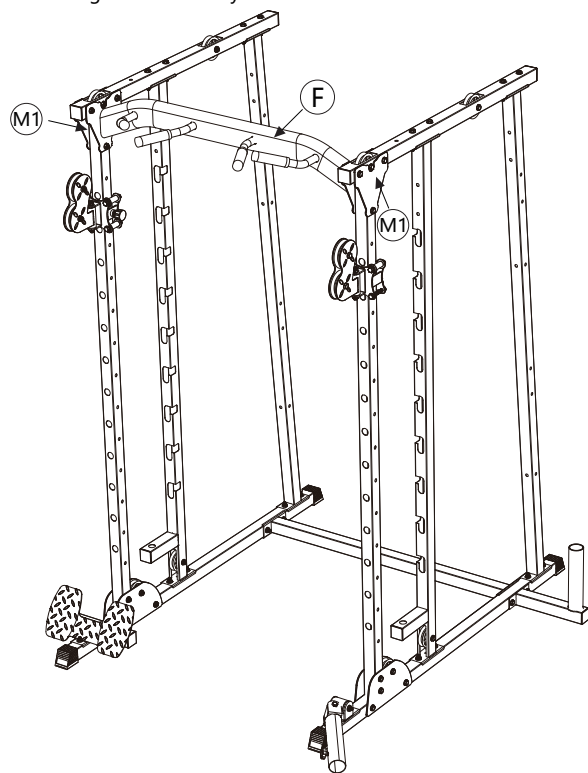

1. Hexagon bolt (M10x70)  6pcs	5. Flat gasket $\varnothing 10$  12pcs	7. Lock nut M10  6pcs		
--	--	---	--	--

Note: Except for pre-installing the hardware you need



Do not tighten all bolts until all installations are complete.

STEP 6.

1. Hexagon bolt (M10x70)  16pcs	5. Flat gasket $\varnothing 10$  32pcs	7. Lock nut M10  16pcs		
---	--	--	--	--

Note: Except for pre-installing the hardware you need

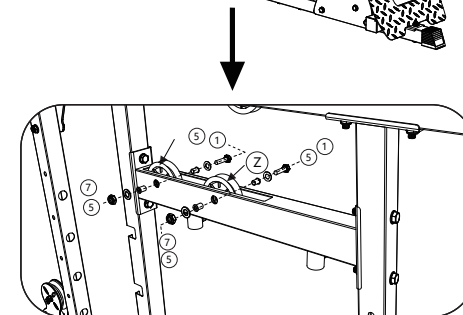
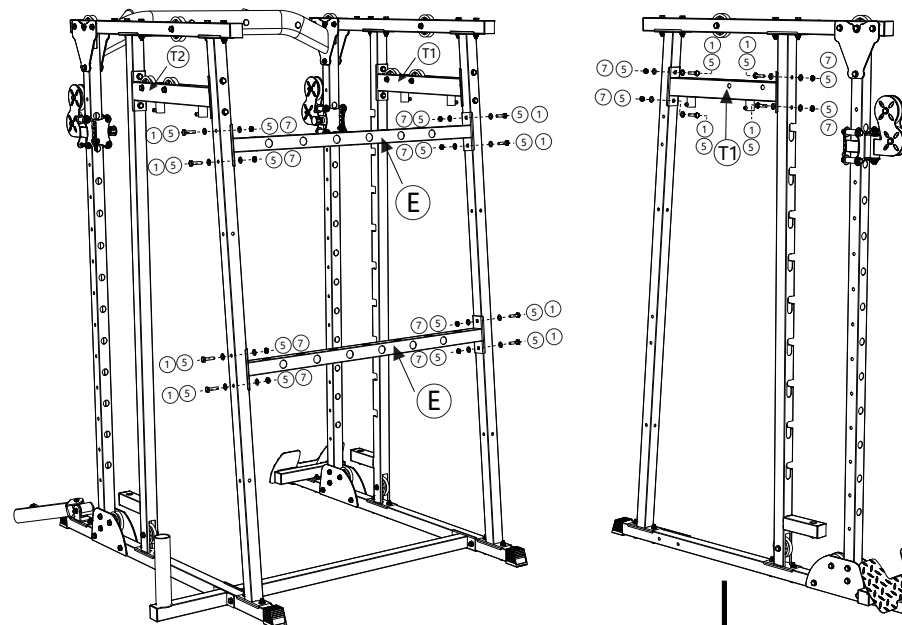

Do not tighten all bolts until all installations are complete.

STEP 7.

2. Hexagon bolt (M10x80)



4pcs

5. Flat gasket $\varnothing 10$



8pcs

7. Lock nut M10



4pcs

Note: Except for pre-installing the hardware you need

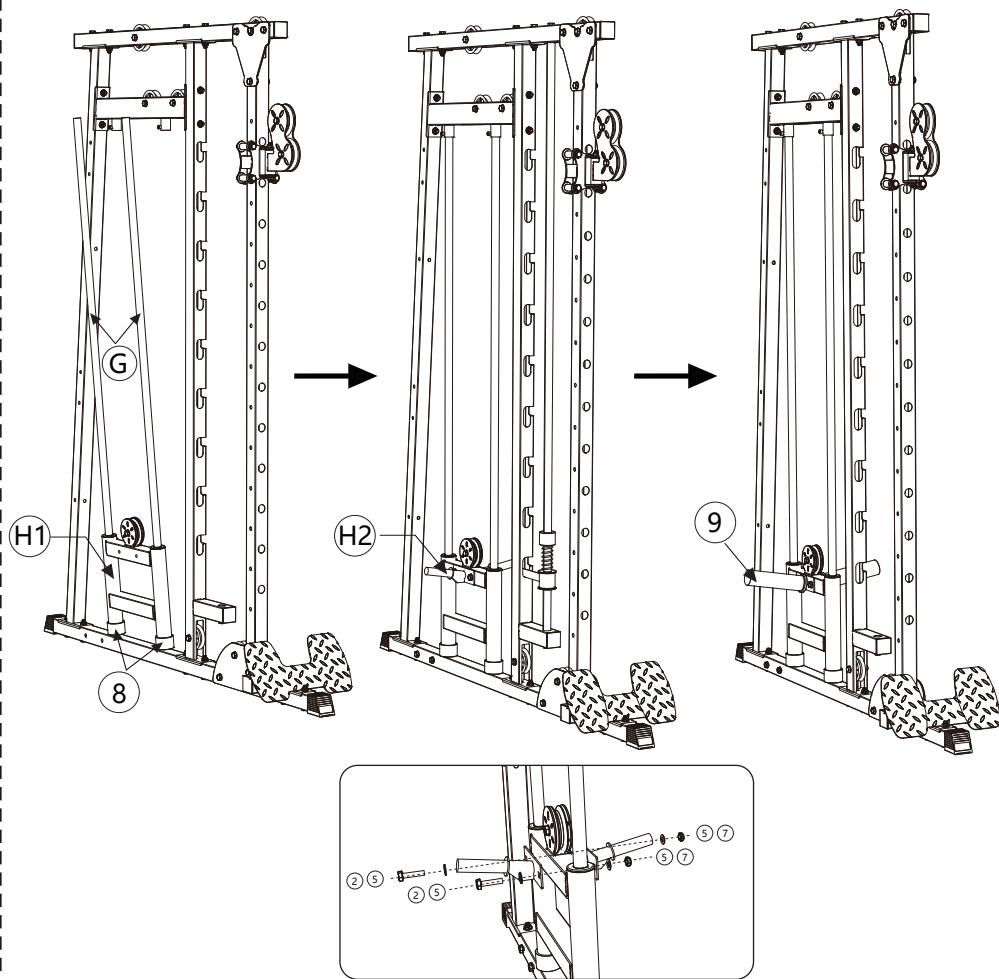

Do not tighten all bolts until all installations are complete.

STEP 8.

4. Hexagon bolt (M12x70)



2pcs

6. Flat gasket $\varnothing 12$



2pcs

Note: Except for pre-installing the hardware you need

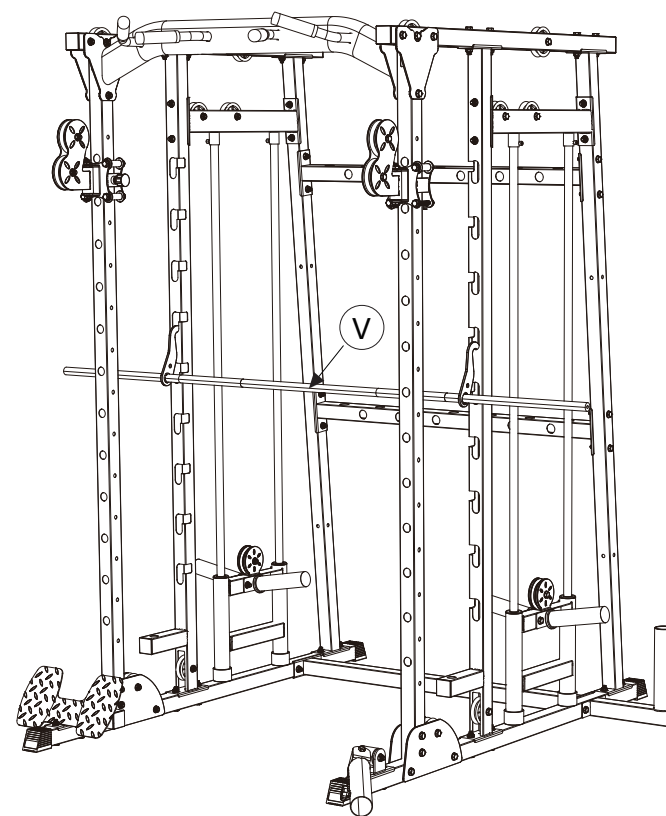

Do not tighten all bolts until all installations are complete.

STEP 9.

9. Stand of Barbell Slice



4pcs

14. DUMBBELL PIECE STORAGE ROD



4pcs

Note: Except for pre-installing the hardware you need

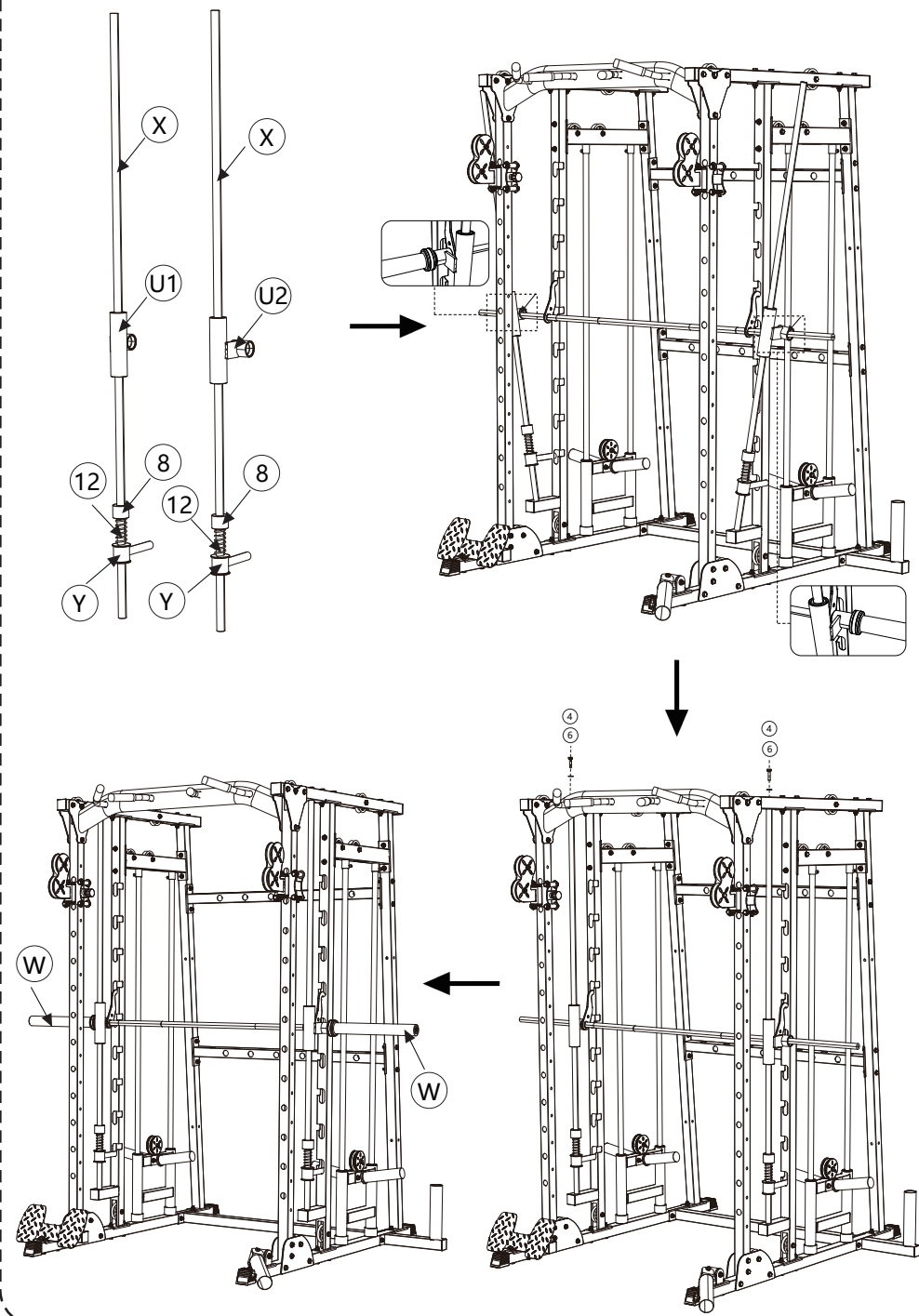
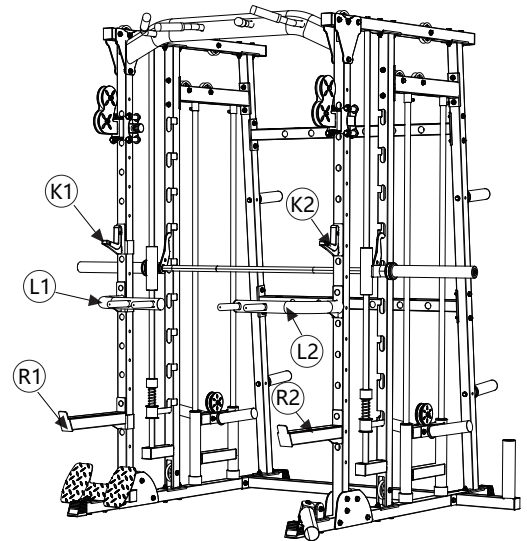
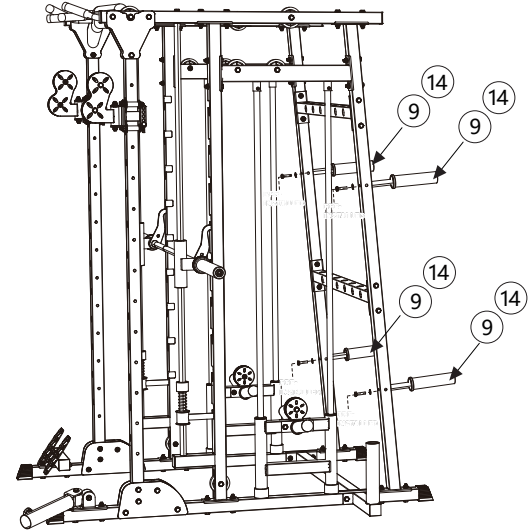

Do not tighten all bolts until all installations are complete.

STEP 9.

3. Hexagon bolt
(M10x25)



2pcs

5. Flat gasket $\varnothing 10$



4pcs

7. Lock nut M10



2pcs

Note: Except for pre-installing the hardware you need

