

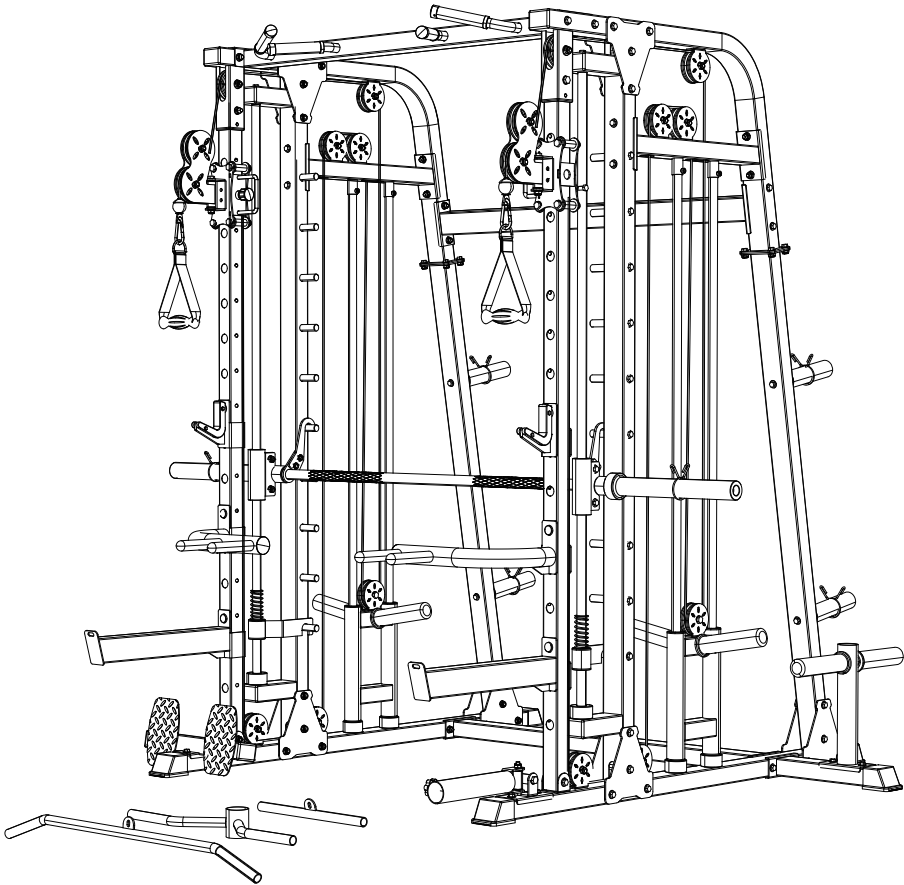

**MAJOR**  
LUTIE FITNESS

**MULTI-FUNCTIONAL  
POWER CAGE  
WITH CABLE MACHINE**

Our after-sale email address: [after-sale@major-lutie.com](mailto:after-sale@major-lutie.com)



AN ASSEMBLY INSTRUCTION

Website:  
[Kjbfitness.com.au](http://Kjbfitness.com.au)  
[major-lutie.com](http://major-lutie.com)



MAJOR LUTIE FITNESS

## SERVICE

For the **best service**, please have the following information ready when requesting for service:

- **Buyer Full Name**
- **Oder Number**
- **Part Number**
- **Part Picture**
- **Model Number**
- **Phone Number**

If you have any questions, receive a damaged part or need additional service support, please contact our customer service department via the following methods:

### **Please Email:**

**after-sale@major-lutie.com**

Response Time: 1-2 Business Days

Emailing us with the information above will be the best method to receive a response.

### **Toll-Free:**

**800-276-8577**

(9:00 AM - 4:00 PM EST, Monday - Friday)

### **Visit Website:**

<https://www.major-lutie.com/>



## GUIDEILNES

Before using this equipment, it is strongly recommended that you consult your physician whether this fitness equipment is applicable to you. Please do not use this machine if you have the following conditions or diseases:

- **Heart Disorders**
- **Recent Stroke or Transient Ischemic Attack**
- **Extreme Obesity**
- **Pregnancy**
- **Bone Weaknesses**
- **Spinal Injury**
- **High Blood Pressure or Hypertension**
- **Hiatus Hernia or Ventral Hernia**
- **In a State of Intoxication or Fatigue**
- **Other diseases that are NOT recommended by doctors for exercise**

**This equipment is designed and intended for home and consumer use only, not for commercial use.**

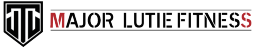

**Please read all instructions carefully before assembling or operating this product.**

This workout equipment is designed and built for optimum safety. However, certain precautions apply whenever you operate this exercise equipment. Be sure to read the entire manual before assembling and operating this equipment. Also, note the following safety instructions:

1. Two people are recommended for the installation of this product instead of one.
2. If you feel dizzy, or other abnormal sensations at any time while operating this device, please stop using the product or exercise and contact your physician as soon as possible.
3. Make sure your equipment is correctly assembled before you use it. Be sure all the screws, nuts, and bolts are tightened prior to use.
4. If this equipment or parts are damaged, do not use it again to exercise.
5. Please do not eat within one hour before using the machine.
6. This product should be placed on a flat surface when using. A mat or other covering material on the ground is recommended.
7. Keep children and pets away from this equipment at all times.
8. It is recommended to wear tight training clothes, tie your hair up, preferably in a ponytail, and remove your jewelry when using this product to avoid unexpected hazards.
9. It is recommended that novice or teenagers should be accompanied by a trainer or parents to use our products, and children under 12 years old are not recommended to use this fitness equipment.
10. The users of this product should keep their weight within 220lb/100kg.

## PREPARATION

### 1. Tools for assembly:

General tools you may need for the assembling this strength equipment:

- **Electric screwdrivers**
- **Hexagon wrench sets**
- **Wrench sets and adjustable wrenches**
- **Rubber Hammer**
- **Lubricant**

2. Insert bolts into the frame as illustrated in the drawing of each of the steps.

3. **Hand-tighten the bolts and nuts during assembly.** Tighten all the hardware once the entire unit has been completely assembled.











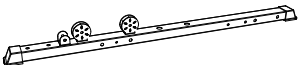
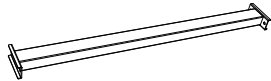

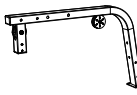
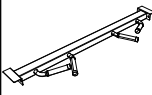
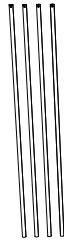
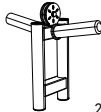
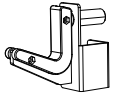
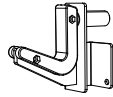

4. With the proper assistance, the right tools, and strictly following the assembly steps, and given enough time.

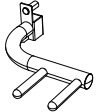
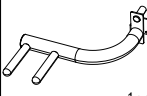
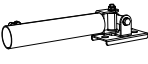
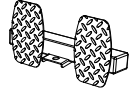
5. Thoroughly read each step before proceeding to assemble the parts of that step.

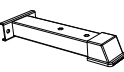
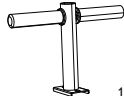

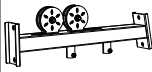

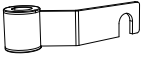
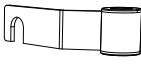

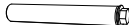







6. To help make it easier for you to assemble the device, we have noted the required hardware in the every steps.

7. When the equipment is fully assembled check all the functions for correct operation. Consult the manual if you experience any issues, or for further help please contact our service department.

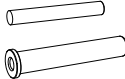
# PARTS LIST



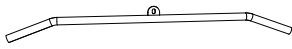
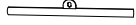

<b>A. UNDERFRAME</b>  2pcs	<b>B. UNDERFRAME/TOPFRAME CONNECTION</b>  2pcs	<b>C1. LEFT-PULLEY SLIDING SLEEVE GUIDE ROD</b>  1pc	<b>C2. RIGHT-PULLEY SLIDING SLEEVE GUIDE ROD</b>  1pc
<b>C3. LEFT-REAR PILLAR</b>  1pc	<b>C4. RIGHT-REAR PILLAR</b>  1pc	<b>D. TOPFRAME</b>  2pcs	<b>F. PULL-UP FRAME</b>  1pc
		<b>G. WEIGHT FRAME GUIDE ROD</b>  4pcs	<b>H. WEIGHT FRAME</b>  2pcs
<b>K1. LEFT-BARRELL SAFETY HOOK</b>  1pc	<b>K2. RIGHT-BARRELL SAFETY HOOK</b>  1pc		<b>M. SUPPORT RACK</b>  12pcs
<b>L1. LEFT-HANDLEBAR</b>  1pc	<b>L2. RIGHT-HANDLEBAR</b>  1pc	<b>N. WEIGHT ROD SLEEVE</b>  1pc	<b>O. PEDAL</b>  1pc
		<b>P. CABLE</b>  2pcs	
<b>Q1. WEIGHT STORAGE BASE</b>  1pc	<b>Q2. WEIGHT STORAGE RACK</b>  1pc	<b>R1. LEFT-BARRELL RACK</b>  1pc	<b>R2. RIGHT-BARRELL RACK</b>  1pc
<b>T. TOPFRAME SLIDE ROD CONNECTION</b>  2pc	<b>U. BARRELL BAR GUIDEROD SLIDING SLEEVE</b>  2pcs	<b>V1. BARRELL BAR</b>  1pc	
<b>W1. LEFT-SUPPORT RACK</b>  1pc	<b>W2. RIGHT-SUPPORT RACK</b>  1pc	<b>V2. BARRELL HOOK</b>  2pcs	<b>X. BARRELL BAR GUIDE ROD</b>  2pcs
		<b>Z. BARRELL BAR HOOK ROD</b>  20pcs	

# HARDWARE LIST

<p><b>1. BOLT(M10*90)</b></p>  <p style="text-align: center;">36pcs</p>	<p><b>2. BOLT(M10*80)</b></p>  <p style="text-align: center;">2pcs</p>	<p><b>3. BOLT(M10*70)</b></p>  <p style="text-align: center;">12pcs</p>	<p><b>4. BOLT(M10*20)</b></p>  <p style="text-align: center;">28pcs</p>	<p><b>5. LOCKNUT(M10)</b></p>  <p style="text-align: center;">66pcs</p>	<p><b>6. WASHER(M10)</b></p>  <p style="text-align: center;">144pcs</p>
<p><b>7. SHOCK PAD</b></p>  <p style="text-align: center;">6pcs</p>	<p><b>8. HANDLEBAR</b></p>  <p style="text-align: center;">2pcs</p>	<p><b>9. DUMBBELL PIECE STORAGE ROD</b></p>  <p style="text-align: center;">4pcs</p>	<p><b>10. CLIP</b></p>  <p style="text-align: center;">2pcs</p>	<p><b>11. BUTTERFLY CLIP</b></p>  <p style="text-align: center;">6pcs</p>	<p><b>12. BUTTERFLY CLIP</b></p>  <p style="text-align: center;">2pcs</p>
<p><b>13. LAT PULL-DOWN BAR</b></p>  <p style="text-align: center;">1pc</p>		<p><b>14. CABLE BAR</b></p>  <p style="text-align: center;">1pc</p>	<p><b>15. V BAR</b></p>  <p style="text-align: center;">1pc</p>		

Note: Please do not fully tighten the screws at the tube connection until the smith bar is installed

**STEP 1.**

<p><b>1. BOLT(M10*90)</b></p>  <p>4pcs</p>	<p><b>4. BOLT(M10*20)</b></p>  <p>6pcs</p>	<p><b>5. LOCKNUT(M10)</b></p>  <p>4pcs</p>	<p><b>6. WASHER(M10)</b></p>  <p>14pcs</p>		
---	---	---	---	--	--

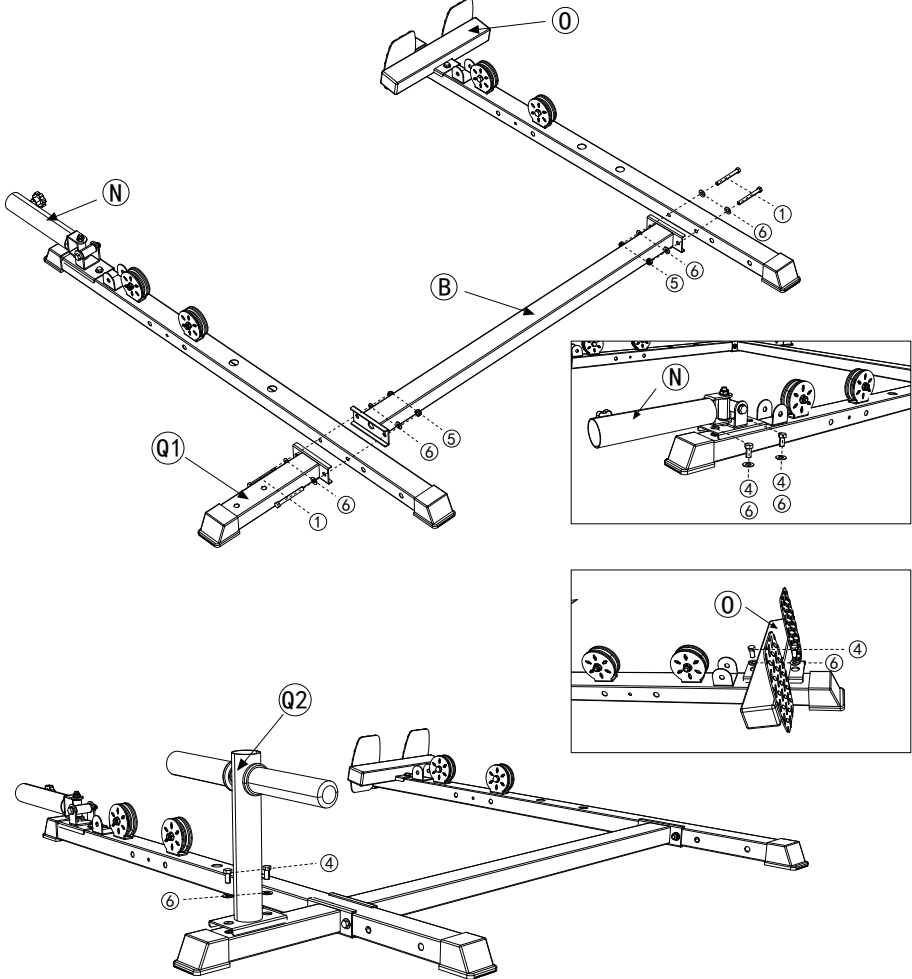

Remarks:Except for pre-installing the hardware you need





## STEP 2.

Note: Please do not fully tighten the screws at the tube connection until the smith bar is installed

1. BOLT(M10*90)  16pcs	5. LOCKNUT(M10)  16pcs	6. WASHER(M10)  32pcs			
---	---	--	--	--	--

Remarks: Except for pre-installing the hardware you need

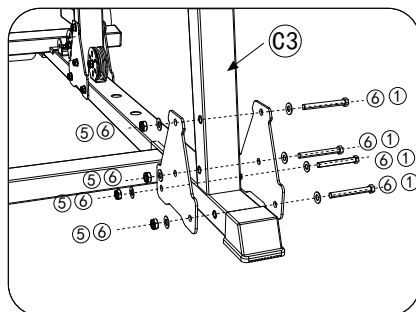
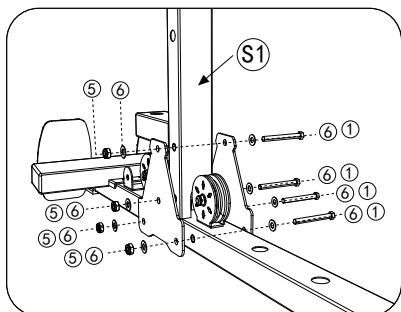
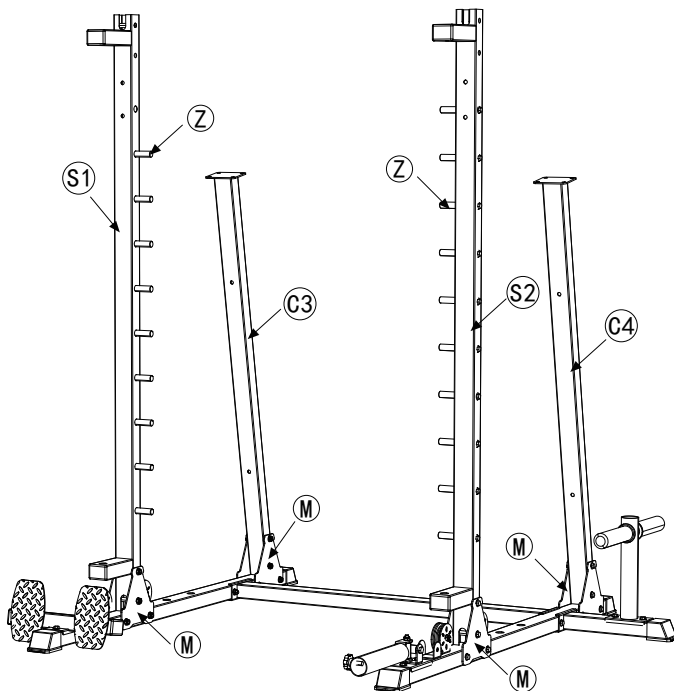

**STEP 3.**

Note: Please do not fully tighten the screws at the tube connection until the smith bar is installed

**3. BOLT(M10\*70)**

2pcs

**4. BOLT(M10\*20)**

8pcs

**5. LOCKNUT(M10)**

8pcs

**6. WASHER(M10)**

18pcs

Remarks: Except for pre-installing the hardware you need

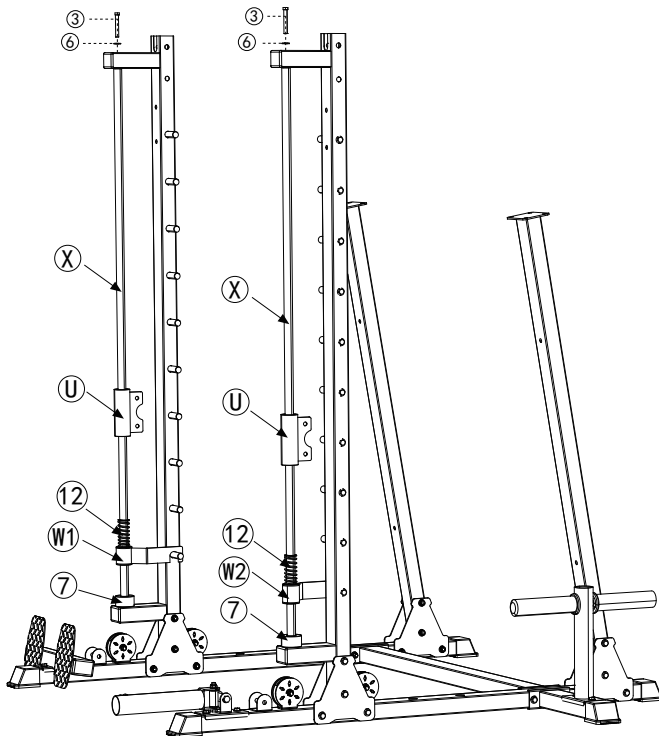

①

V2

V2

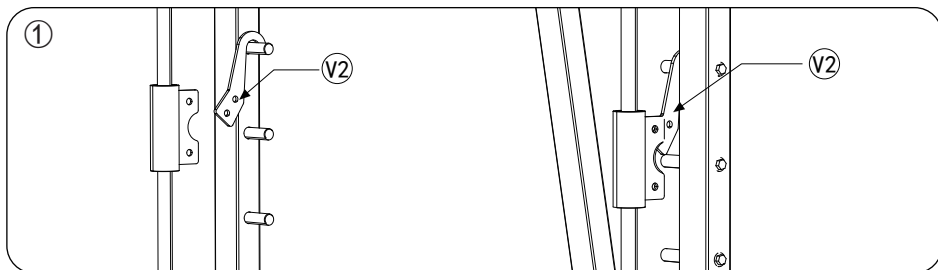

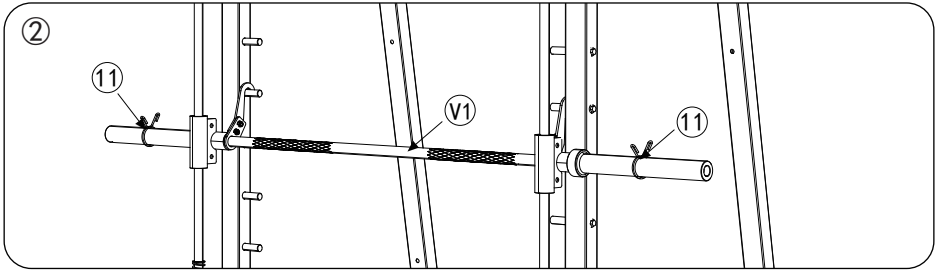

LEFT

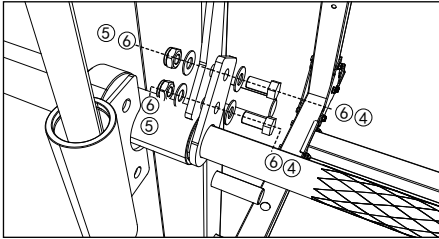

RIGHT

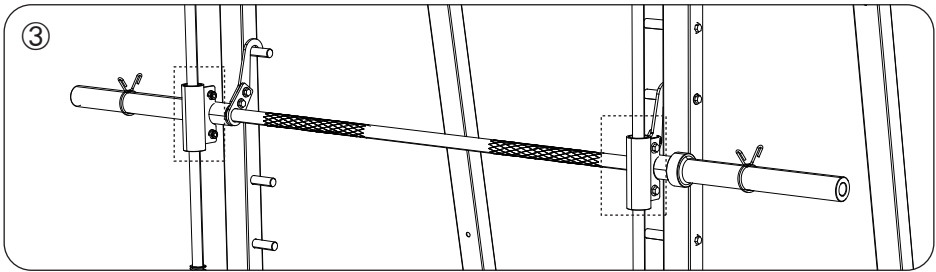
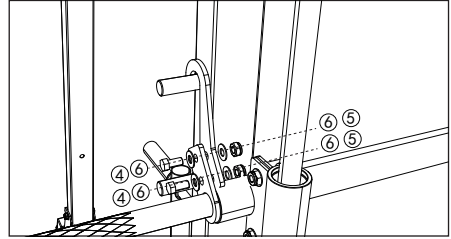

LEFT

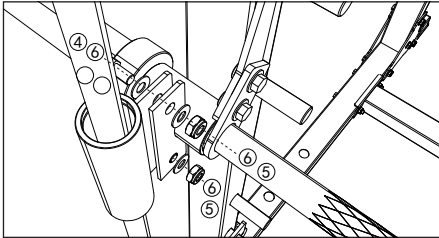



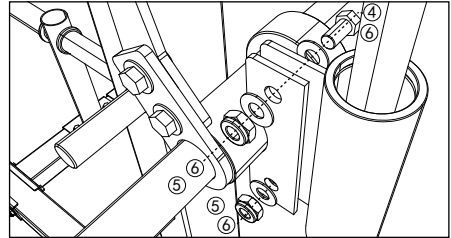

RIGHT



## STEP 4.

Note: Please do not fully tighten the screws at the tube connection until the smith bar is installed



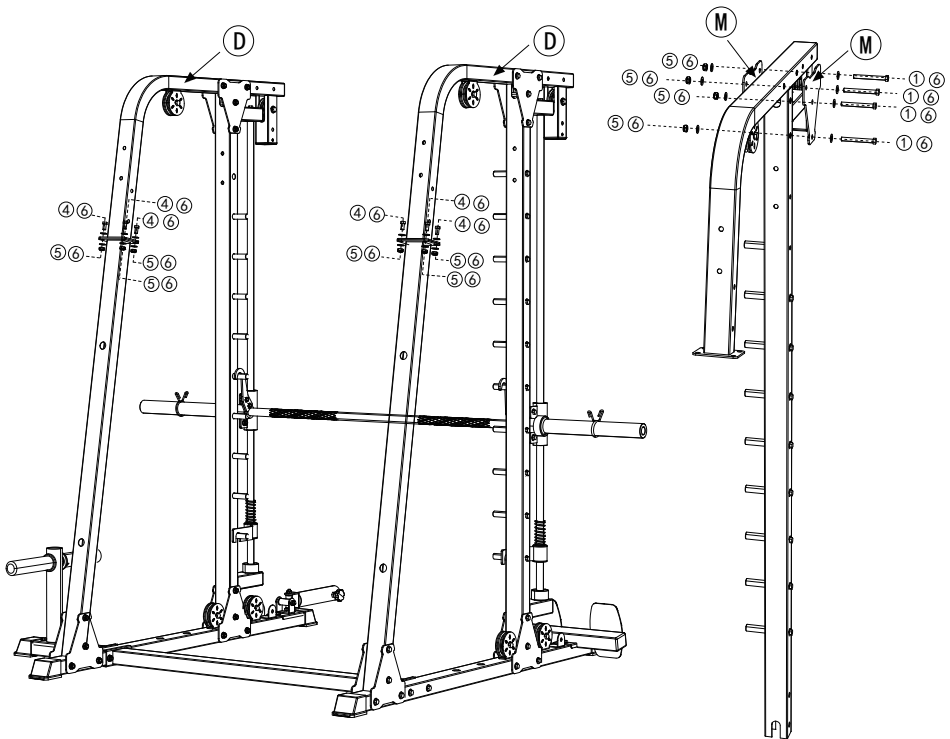

1. BOLT(M10*90)	4. BOLT(M10*20)	5. LOCKNUT(M10)	6. WASHER(M10)		
					
8pcs	8pcs	16pcs	32pcs		

Remarks: Except for pre-installing the hardware you need



**STEP 5.**

Note: Please do not fully tighten the screws at the tube connection until the smith bar is installed

<b>1. BOLT(M10*90)</b>  4pcs	<b>3. BOLT(M10*70)</b>  8pcs	<b>5. LOCKNUT(M10)</b>  12pcs	<b>6. WASHER(M10)</b>  24pcs		
---	---	--	---	--	--

Remarks: Except for pre-installing the hardware you need

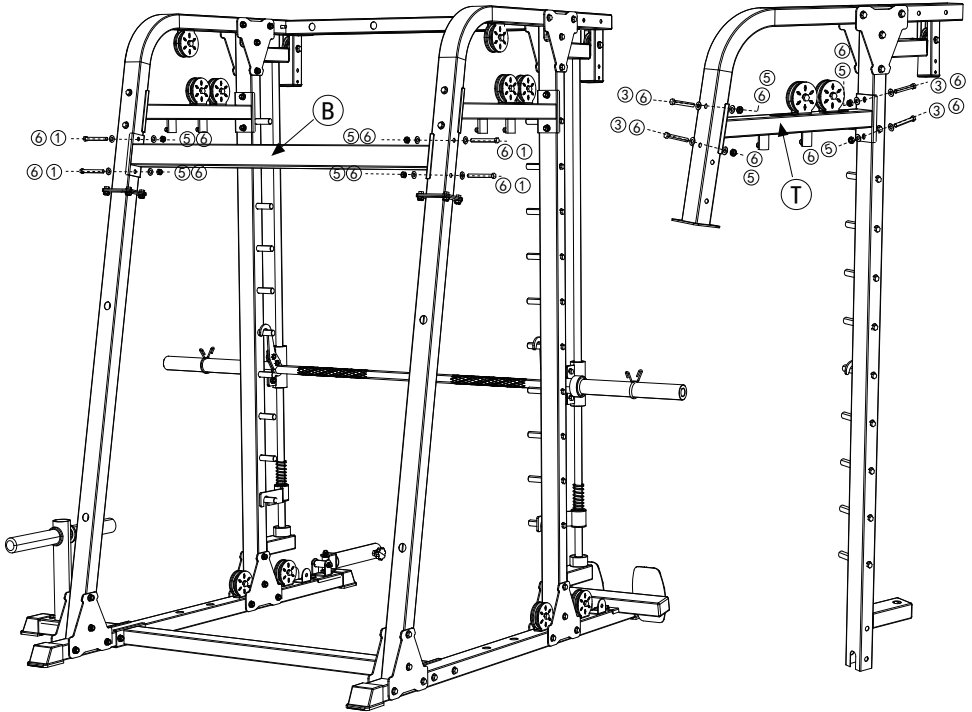

**STEP 6.**

Note: Please do not fully tighten the screws at the tube connection until the smith bar is installed

1. BOLT(M10\*90)



4pcs

5. LOCKNUT(M10)



4pcs

6. WASHER(M10)



8pcs

Remarks:Except for pre-installing the hardware you need

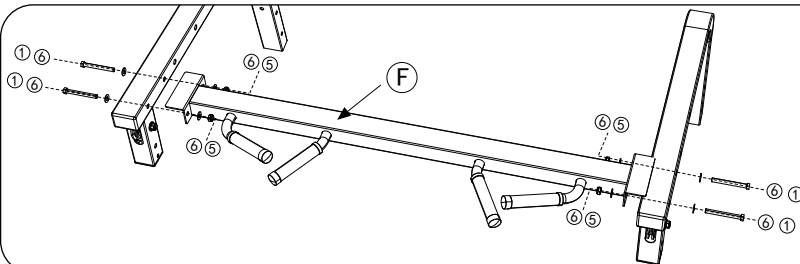
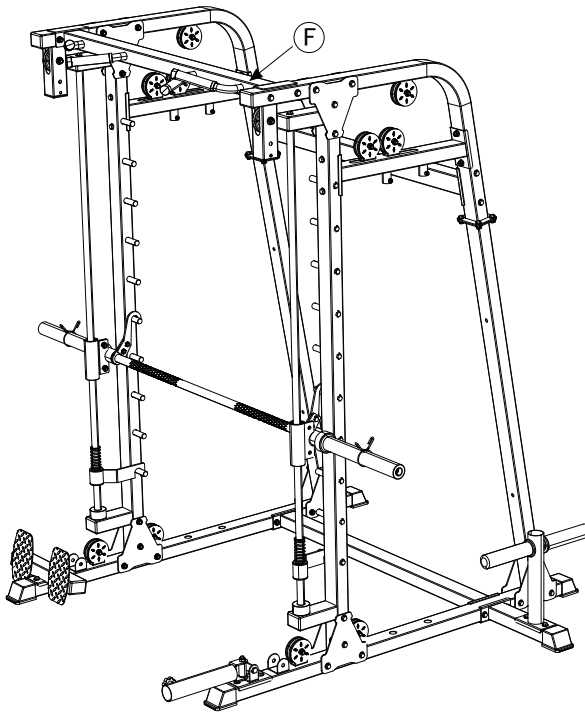

**STEP 7.**

Note: Please do not fully tighten the screws at the tube connection until the smith bar is installed

7. SHOCK PAD





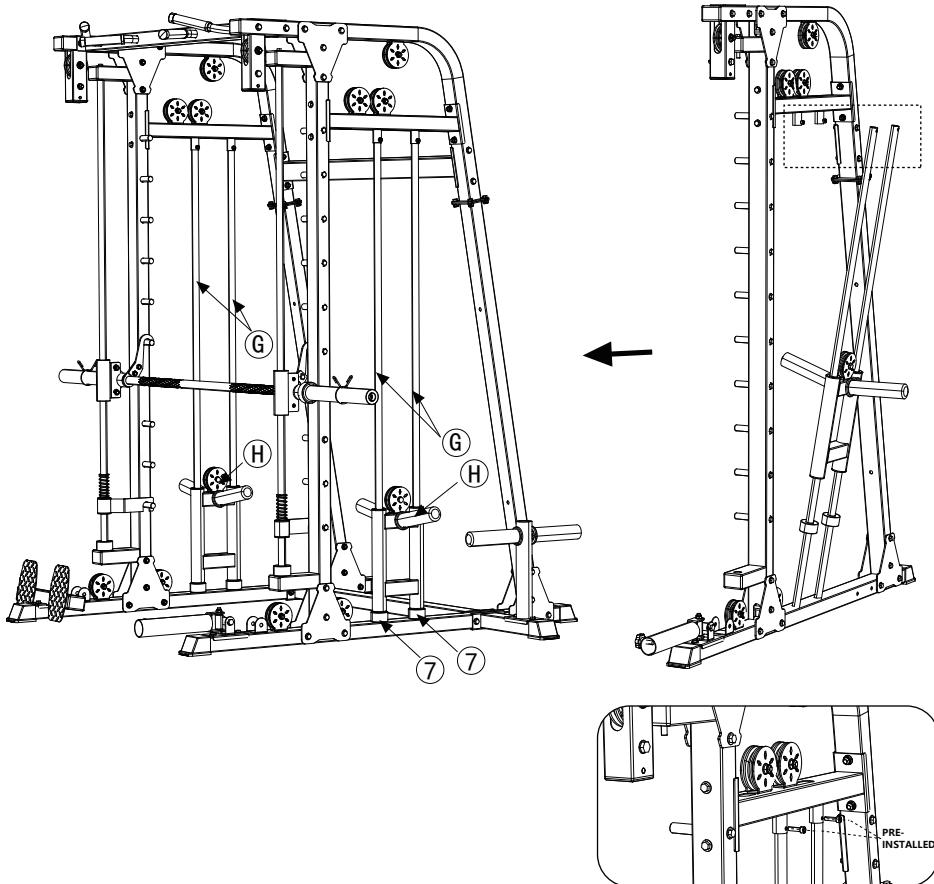

4pcs

Remarks: Except for pre-installing the hardware you need



**STEP 8.**

Note: Please do not fully tighten the screws at the tube connection until the smith bar is installed

<p><b>2. BOLT(M10*80)</b></p>  <p>2pcs</p>	<p><b>5. LOCKNUT(M10)</b></p>  <p>4pcs</p>	<p><b>6. WASHER(M10)</b></p>  <p>8pcs</p>	<p><b>3. BOLT(M10*70)</b></p>  <p>2pcs</p>		
---	---	--	---	--	--

Remarks: Except for pre-installing the hardware you need

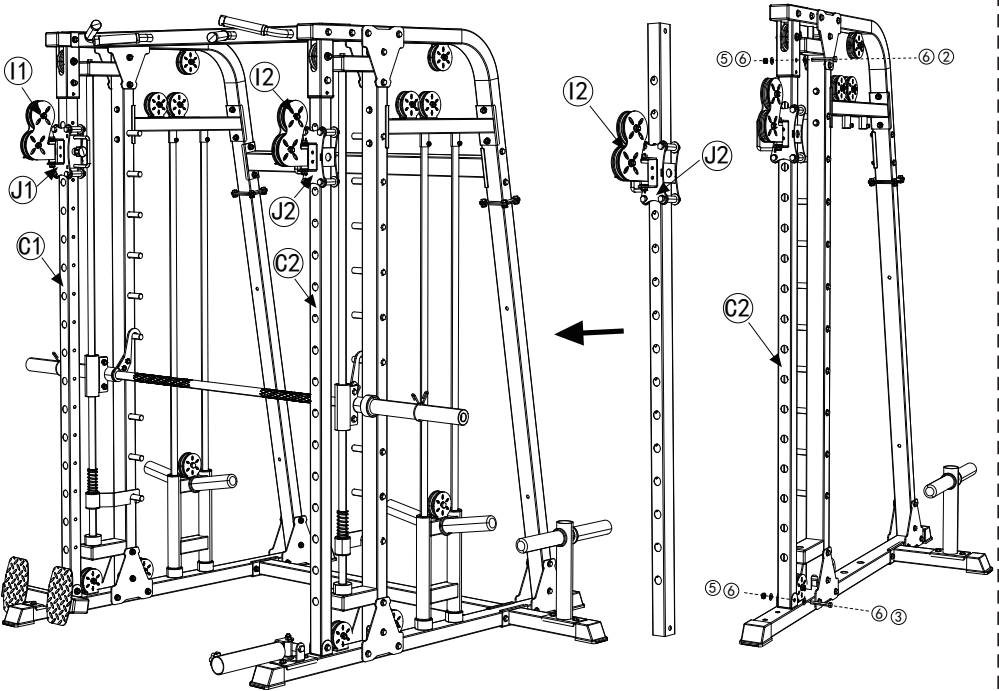



**STEP 9.**

Note: Please do not fully tighten the screws at the tube connection until the smith bar is installed

4. BOLT(M10\*20)



4pcs

6. WASHER(M10)



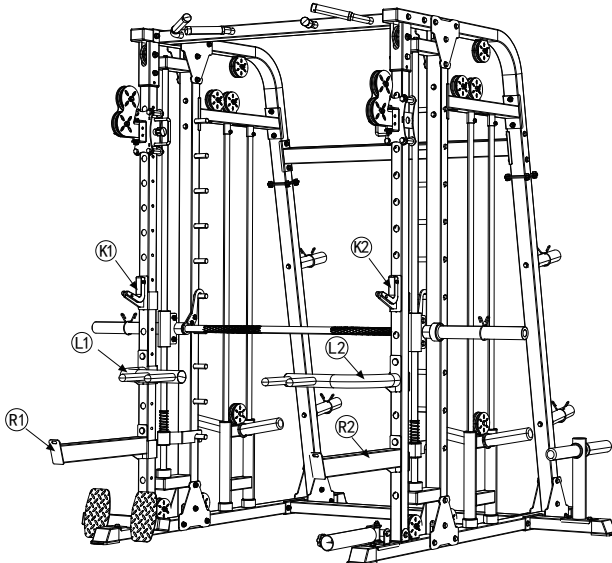
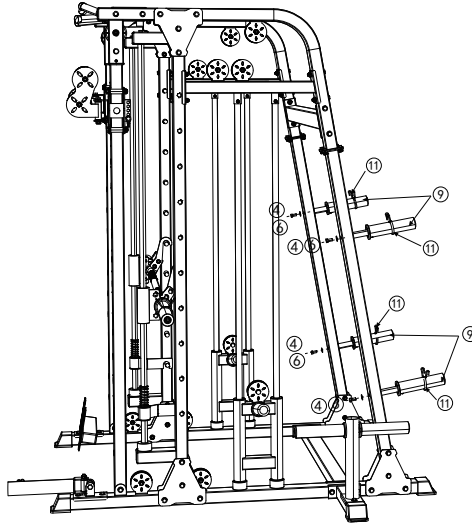

4pcs

Remarks:Except for pre-installing the hardware you need



**STEP 10.**

Note: Please do not fully tighten the screws at the tube connection until the smith bar is installed

<p>4. BOLT(M10*20)</p>  <p>2pcs</p>	<p>5. LOCKNUT(M10)</p>  <p>2pcs</p>	<p>6. WASHER(M10)</p>  <p>4pcs</p>			
--	--	---	--	--	--

Remarks:Except for pre-installing the hardware you need

