

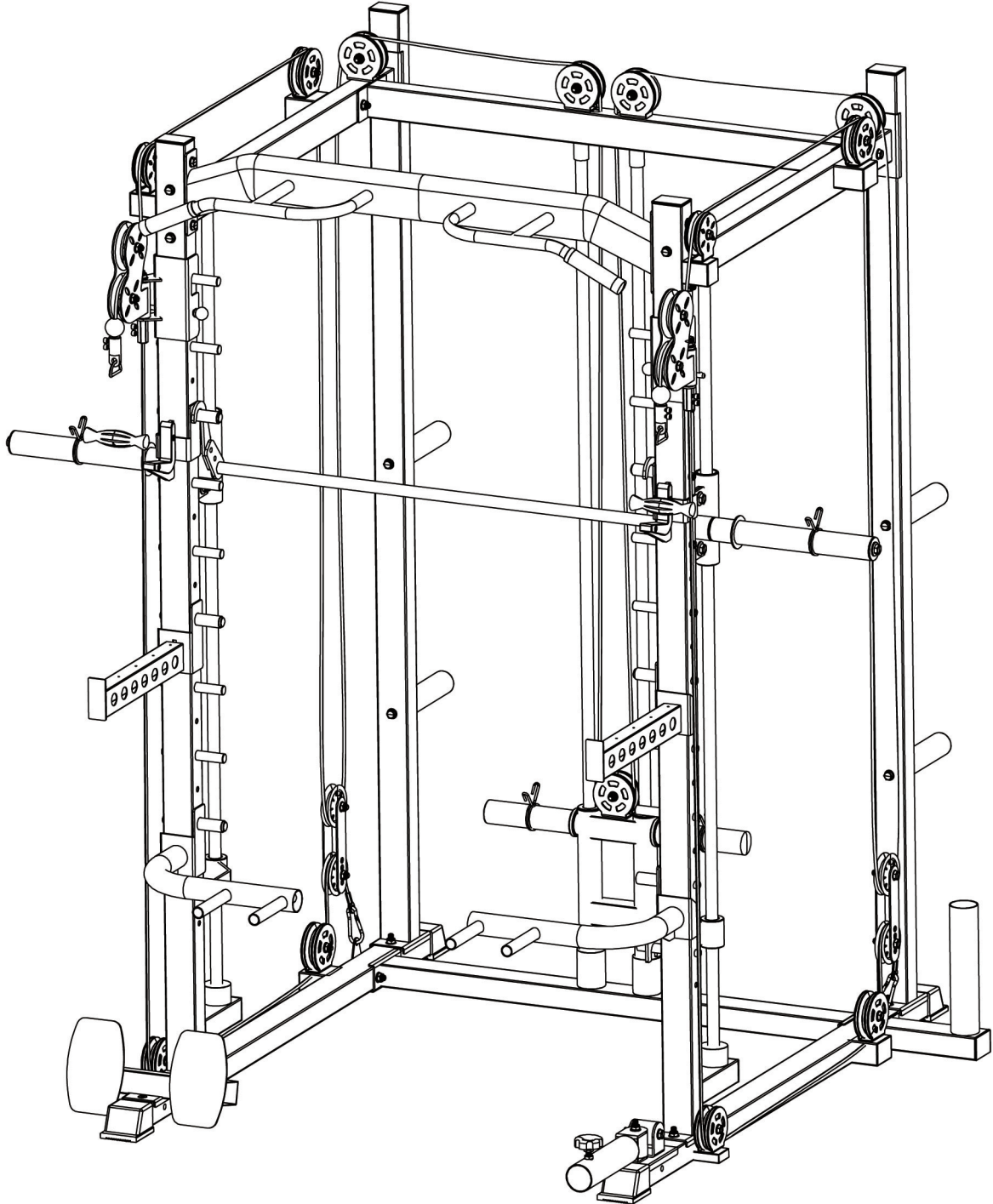

MAJOR
LUTIE FITNESS

MAJOR LUTIE FITNESS SMITH MACHINE SML01







SCAN ME



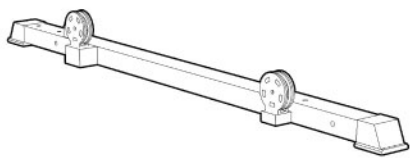
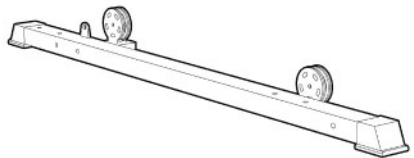
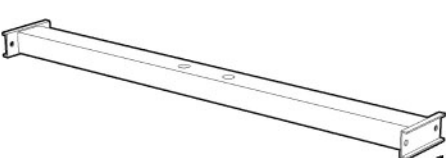
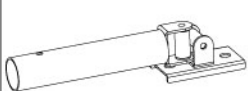
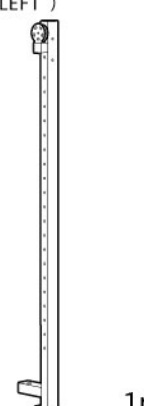
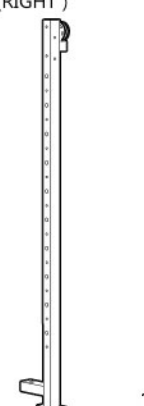
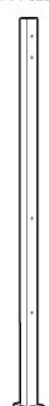
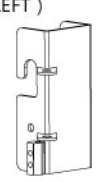

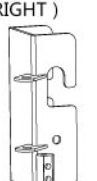
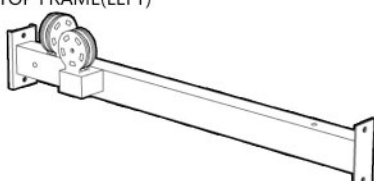
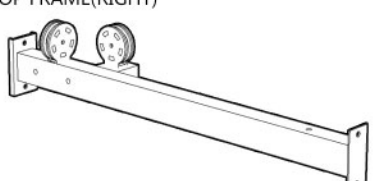
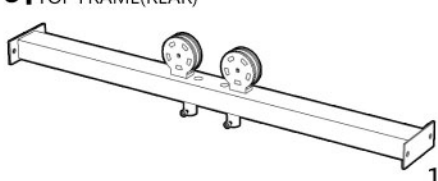
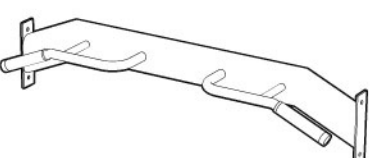
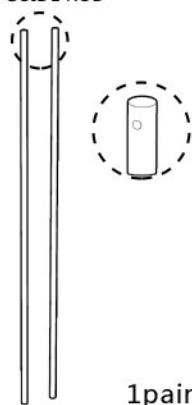
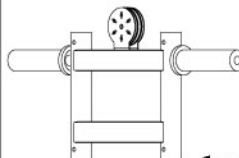
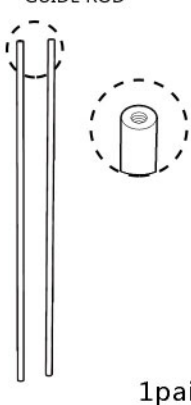

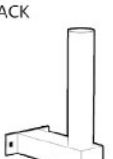
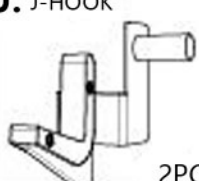
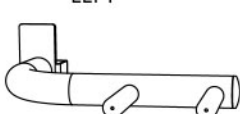
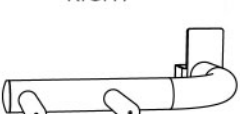
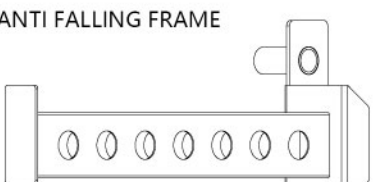
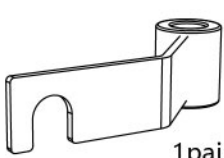



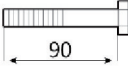



A SSEMBLY INSTRUCTION

Website:
major-lutie.com

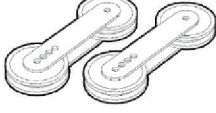

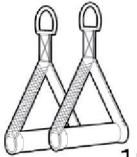
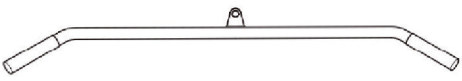
PARTS LIST

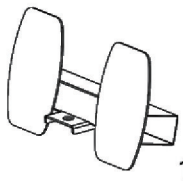
A1. UNDERFRAME(LEFT)  1pc		A2. UNDERFRAME (RIGHT)  1pc		B. UNDERFRAME (REAR)  1pc	
C. BARBELL BAR SLEEVE  1pc		D1. FRONT PILLAR (LEFT)  1pc	D2. FRONT PILLAR (RIGHT)  1pc	D3. REAR PILLAR  2pcs	E1. PULLEY BLOCK HOOK (LEFT)  1pc
E3. PULLEY BLOCK  1pair					E2. PULLEY BLOCK HOOK (RIGHT)  1pc
F1. TOP FRAME(LEFT)  1pc		F2. TOP FRAME(RIGHT)  1pc		F3. TOP FRAME(REAR)  1pc	
F4. PULL UP FRAME  1pc		G1. WEIGHT FRAME GUIDE ROD  1pair	G2. WEIGHT FRAME  1pc	H1. BARBELL BAR GUIDE ROD  1pair	H2. BARBELL BAR GUIDE RODSLIDING SLEEVE  1pair
H3. BARBELL BAR  1pc					
I. WEIGHT STORAGE RACK  1pc	J. J-HOOK  2PCS	K1. HANDLEBAR LEFT  1PC	K2. HANDLEBAR RIGHT  1PC	L. ANTI FALLING FRAME  1 Pair	
M. Support Rack  1pair					

HARDWARE LIST

1. BOLT(M10*90)  8 pcs	2. BOLT(M10*70)  20 pcs	3. BOLT(M10*25)  16 pcs	4. LOCKNUT(M10)  38 pcs	5. WASHER(M10)  82 pcs	6. SHOCK PAD  6 pcs
7. SAFETY PIN  2 pcs	8. DUMBBELL PIECE STORAGE RACK  4 pcs	9. BARBELL BAR HOOK PIN  18 pcs	10. MOVING PULLEY  1 pair	11. CLIP  2 pcs	12. HANDLEBAR  1 pair
13. LAT PULL-DOWN BAR  1 PC	14. CABLE BAR  1 PC	15. T-BAR  1 PC	16. PEDAL  1 PC	17. PROTECTION ROD  2 pcs	

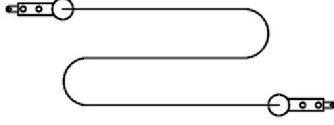
CABLE LIST

CABLE A. (LONG)  1 pc	CABLE B. (SHORT)  2 pcs
---	---

STEP 1. Assemble the chassis:

Connect B to A1, connect A2 to 1+4+5, use 3+5 to fix C1 and 16 to the corresponding hole of A1 or A2, and fix I to the corresponding hole of A2.

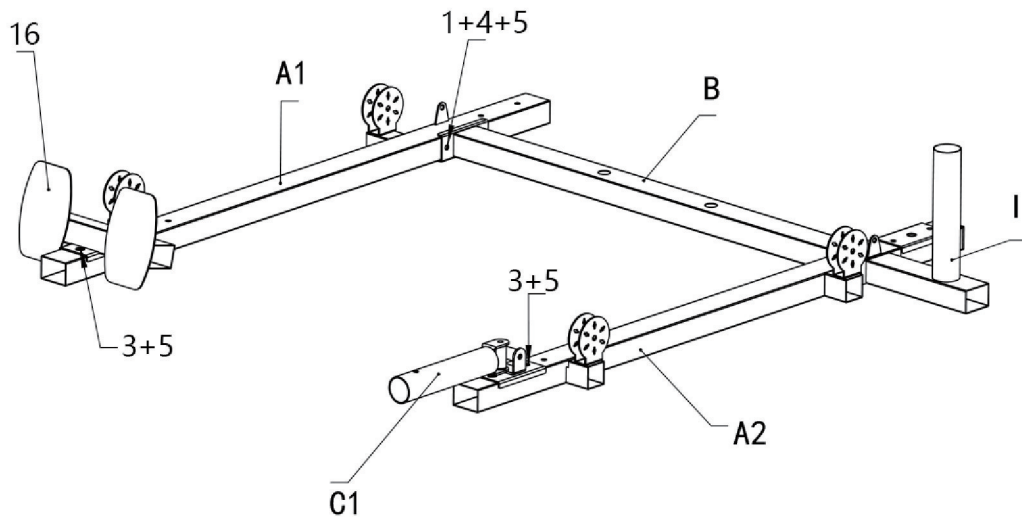

STEP 2. Install the column:

Use 2+4+5 to fix D1, D2 and D3 on the corresponding position of the base, 7 use the built-in hexagon socket head bolt to fix the corresponding hole position of D1, D2, E1, E2 are installed on the base at the corresponding position as shown in the figure, E3 uses the built-in hexagon bolts. Bolt on E1, insert 7 into the corresponding hole of D1 and D2 through E1 and E2, insert 12 into the corresponding hole of D1 and D2, and insert 8 into the corresponding hole of D3.

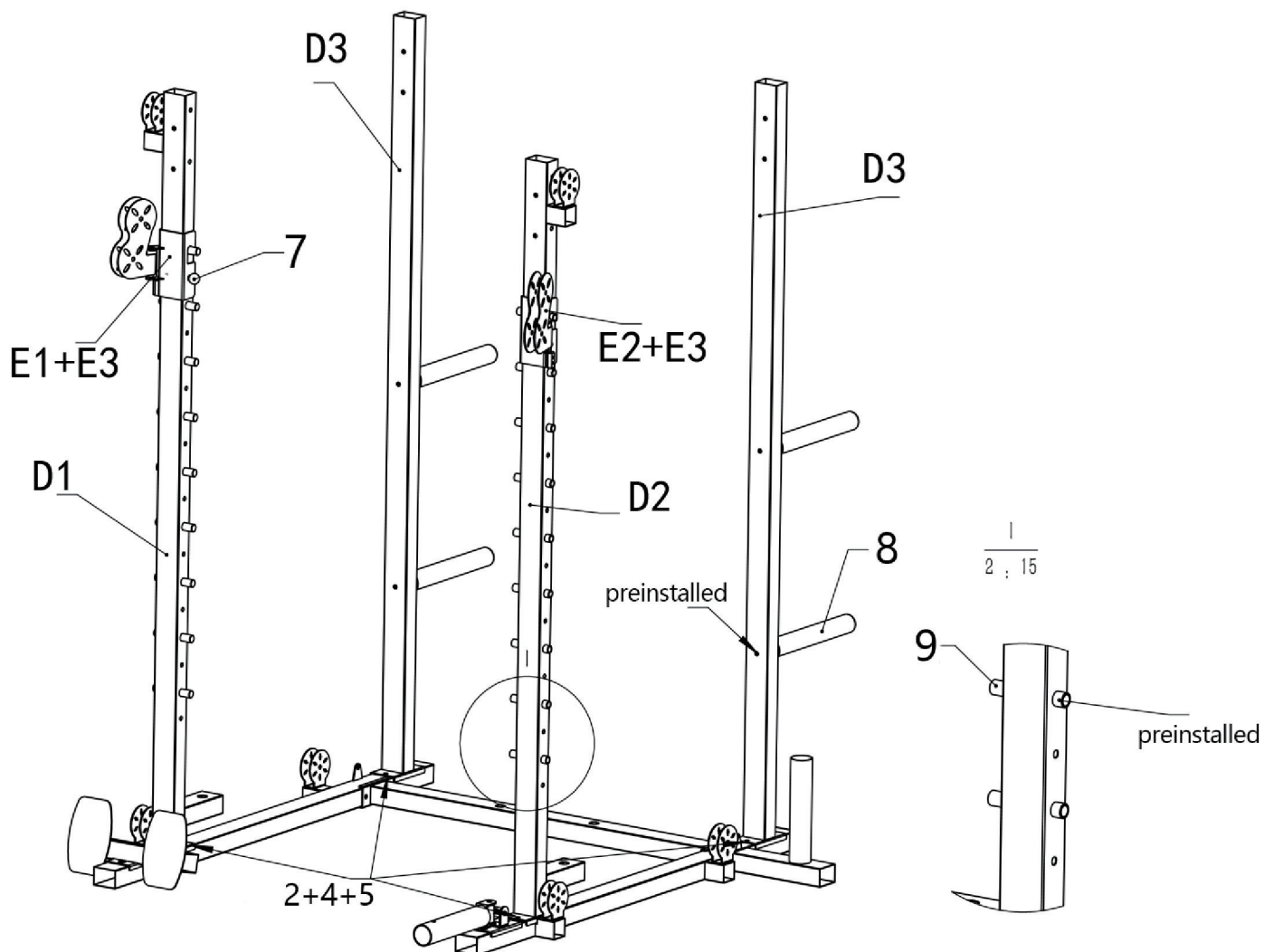

STEP 3. Install the top frame:

Use 1+4+5 to connect F4 and D1, D2 upper holes, 1+4+5 to connect F4 to D1, D2 lower holes, F1 to connect D1, D3 and fix with 2+4+5, F2 to connect D2 and D3 with 2+ 4+5 fixed, F3 connects F1 and F2 with 2+4+5 fixed.

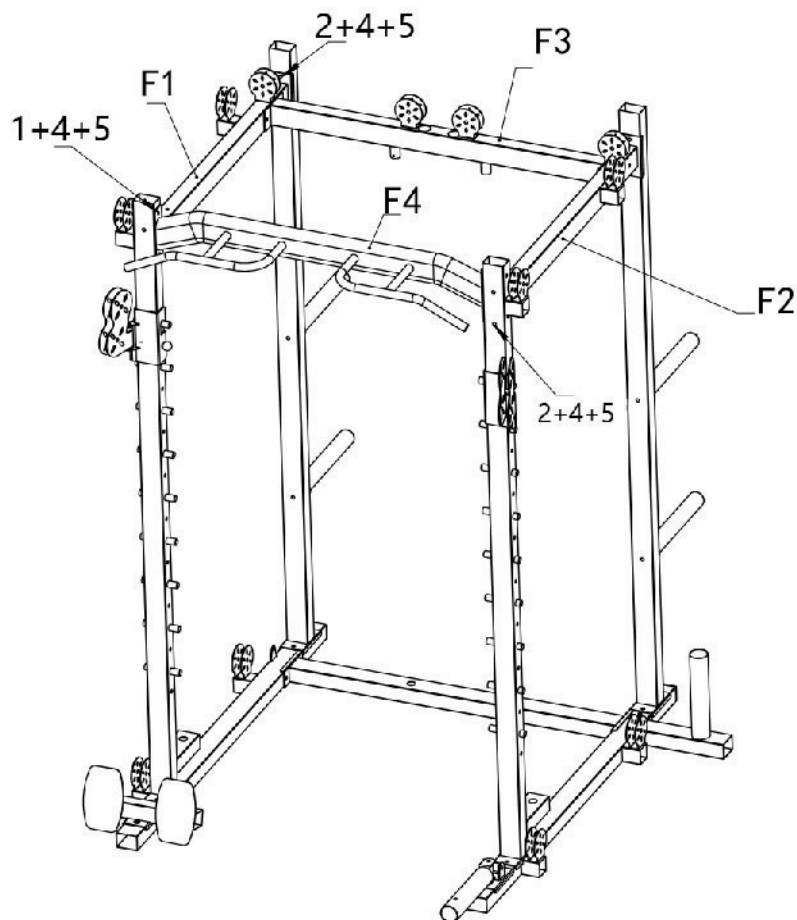

STEP 4. Install the counterweight frame:

Insert G1 to G2 and 6 into the holes corresponding to B, insert G1 upwards into the holes corresponding to F3, and fix them with hexagon socket head bolts.

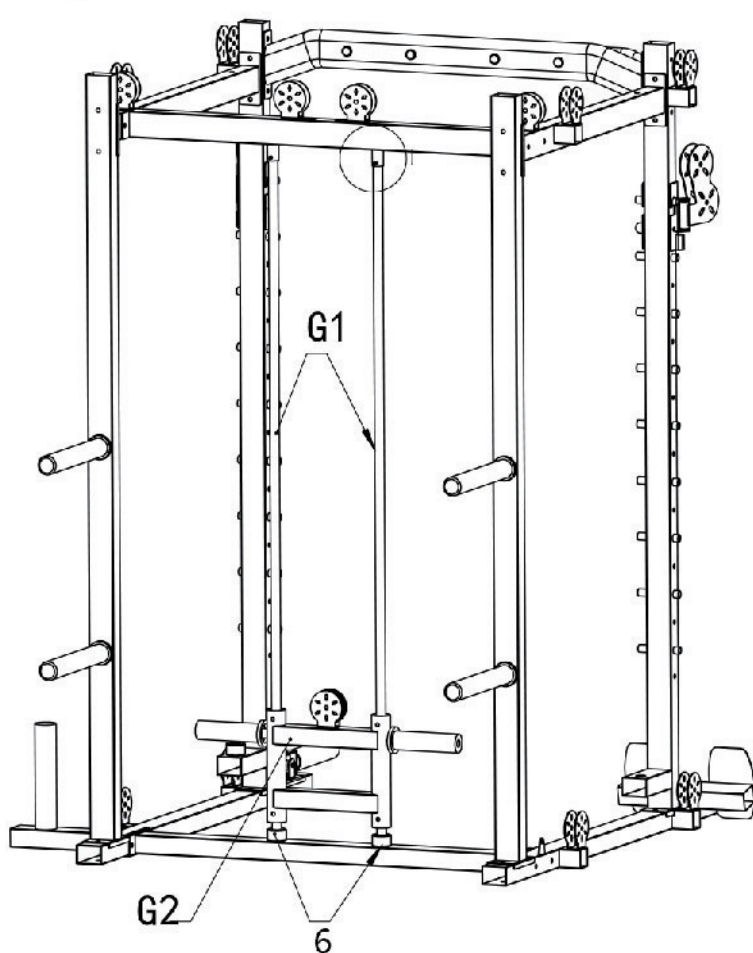

$\frac{1}{1,3}$



STEP 3. Install the top frame:

Use 1+4+5 to connect F4 and D1, D2 upper holes, 1+4+5 to connect F4 to D1, D2 lower holes, F1 to connect D1, D3 and fix with 2+4+5, F2 to connect D2 and D3 with 2+ 4+5 fixed, F3 connects F1 and F2 with 2+4+5 fixed.

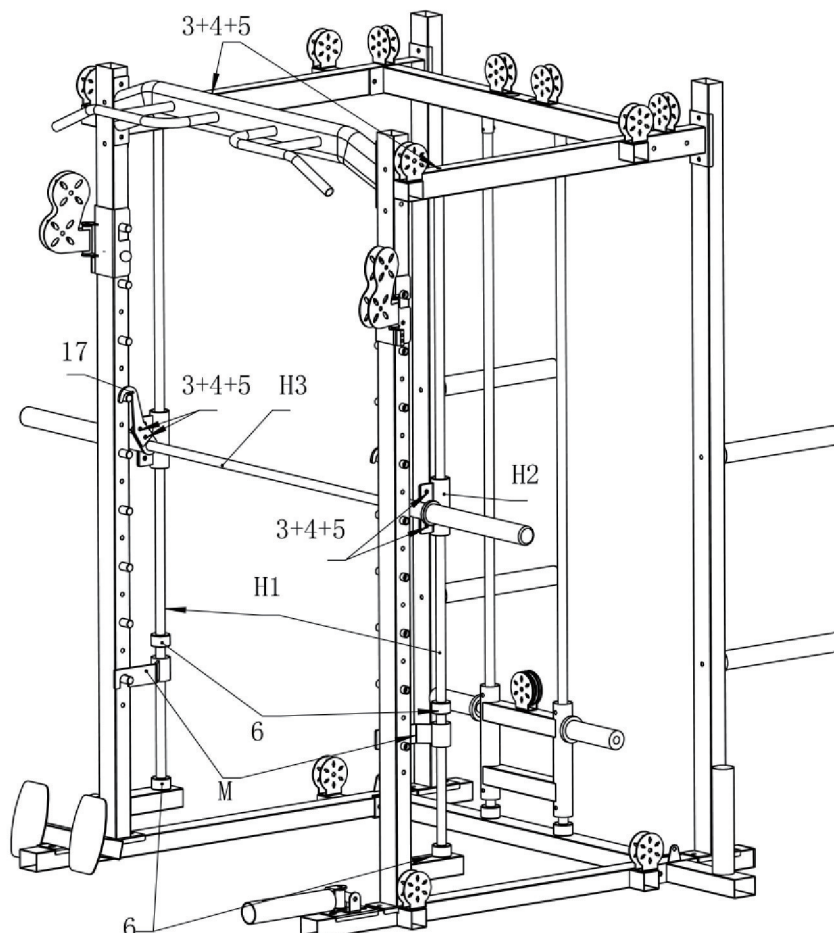

STEP 4. Install the counterweight frame:

Insert G1 to G2 and 6 into the holes corresponding to B, insert G1 upwards into the holes corresponding to F3, and fix them with hexagon socket head bolts.

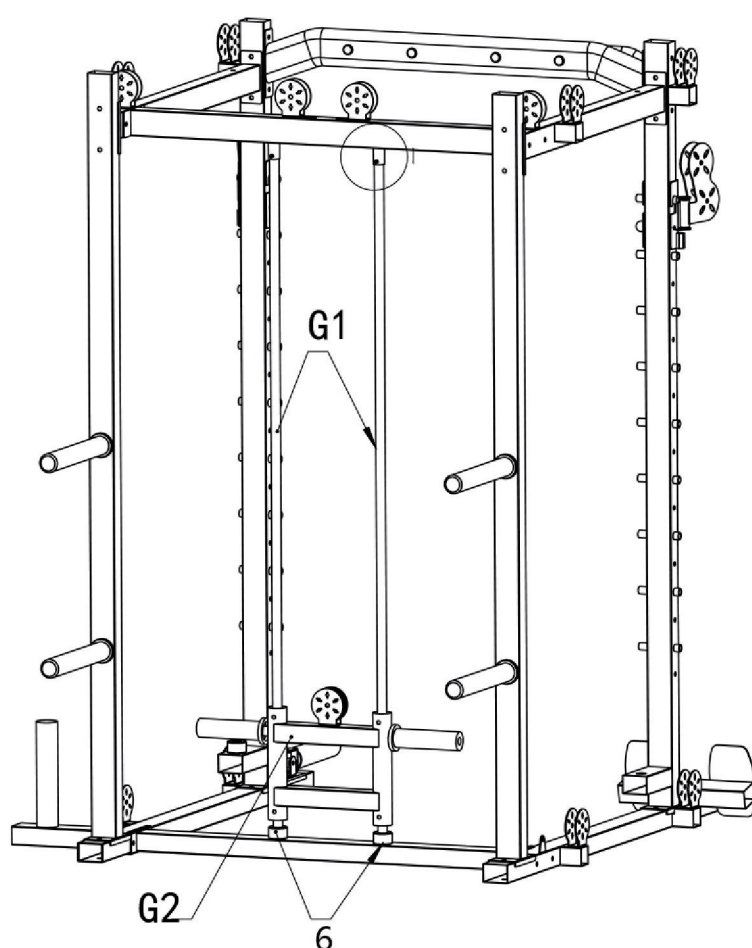

$\frac{1}{1:3}$

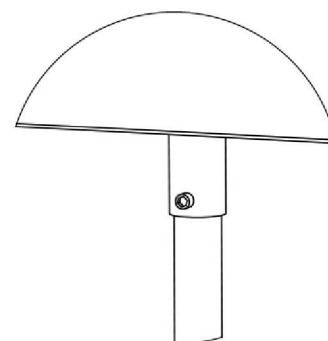

STEP 6-2. Rear view

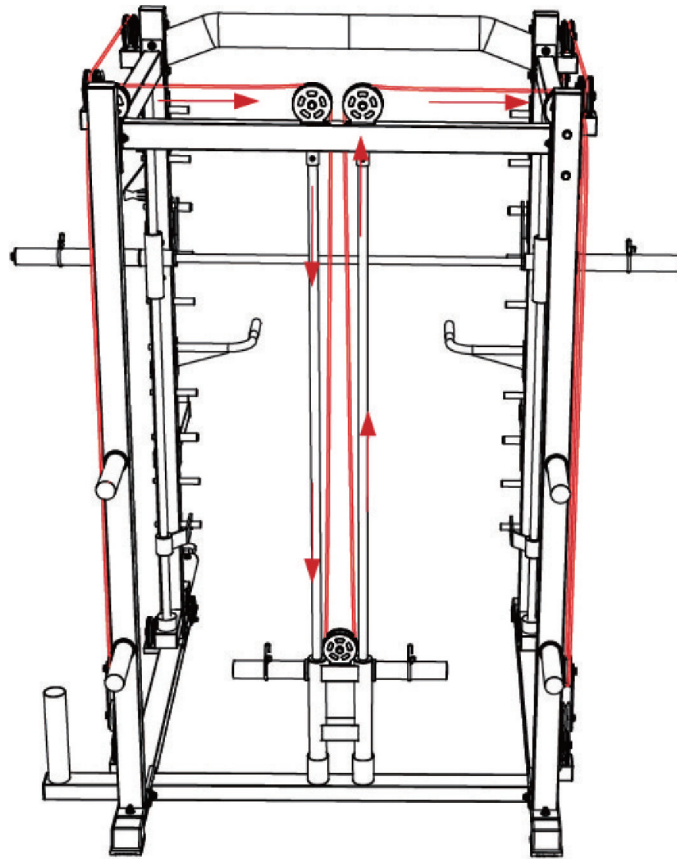

STEP 7. Install rope group B:

Use 3+4+5 to connect the B rope with the holes corresponding to A1 and A2, pass the other end of the B rope through each pulley and pulley block in turn, insert it into the hole as shown in the figure, and tighten the hexagon socket head bolt.

