



The power cage includes three packages , please confirm before installation

PLM 03



Website:
major-lutie.com

Email:
after-sale@major-lutie.com

Website:

major-lutie.com

After-sales service:

after-sale@major-lutie.com



SERVICE

For the **best service**, please have the following information ready when requesting for service:

- **Buyer Full Name**
- **Order Number**
- **Part Number**
- **Part Picture**
- **Model Number**
- **Phone Number**

If you have any questions, receive a damaged part or need additional service support, please contact our customer service department via the following methods:

Please Email:

after-sale@major-lutie.com

Response Time: 1-2 Business Days

Emailing us with the information above will be the best method to receive a response.

Toll-Free:

800-276-8577

(9:00 AM - 4:00 PM EST, Monday - Friday)

Visit Website:

major-lutie.com



GUIDEILNES

Before using this equipment, it is strongly recommended that you consult your physician whether this fitness equipment is applicable to you. Please do not use this machine if you have the following conditions or diseases:

- **Heart Disorders**
- **Recent Stroke or Transient Ischemic Attack**
- **Extreme Obesity**
- **Pregnancy**
- **Bone Weaknesses**
- **Spinal Injury**
- **High Blood Pressure or Hypertension**
- **Hiatus Hernia or Ventral Hernia**
- **In a State of Intoxication or Fatigue**
- **Other diseases that are NOT recommended by doctors for exercise**

This equipment is designed and intended for home and consumer use only, not for commercial use.



Please read all instructions carefully before assembling or operating this product.

This workout equipment is designed and built for optimum safety. However, certain precautions apply whenever you operate this exercise equipment. Be sure to read the entire manual before assembling and operating this equipment. Also, note the following safety instructions:

1. Two people are recommended for the installation of this product instead of one.
2. If you feel dizzy, or other abnormal sensations at any time while operating this device, please stop using the product or exercise and contact your physician as soon as possible.
3. Make sure your equipment is correctly assembled before you use it. Be sure all the screws, nuts, and bolts are tightened prior to use.
4. If this equipment or parts are damaged, do not use it again to exercise.
5. Please do not eat within one hour before using the machine.
6. This product should be placed on a flat surface when using. A mat or other covering material on the ground is recommended.
7. Keep children and pets away from this equipment at all times.
8. It is recommended to wear tight training clothes, tie your hair up, preferably in a ponytail, and remove your jewelry when using this product to avoid unexpected hazards.
9. It is recommended that novice or teenagers should be accompanied by a trainer or parents to use our products, and children under 12 years old are not recommended to use this fitness equipment.
10. The users of this product should keep their weight within 220lb/100kg.

PREPARATION

1. Tools for assembly:

General tools you may need for the assembling this strength equipment:

- **Electric screwdrivers**
- **Hexagon wrench sets**
- **Wrench sets and adjustable wrenches**
- **Rubber Hammer**
- **Lubricant**

2. Insert bolts into the frame as illustrated in the drawing of each of the steps.

3. **Hand-tighten the bolts and nuts during assembly.** Tighten all the hardware once the entire unit has been completely assembled.

4. With the proper assistance, the right tools, and strictly following the assembly steps, and given enough time.



5. Thoroughly read each step before proceeding to assemble the parts of that step.

6. To help make it easier for you to assemble the device, we have noted the required hardware in the every steps.

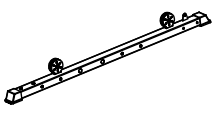
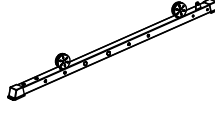
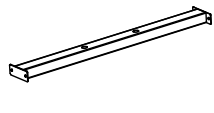
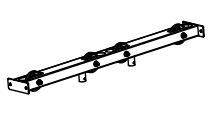
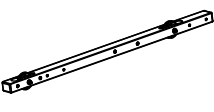
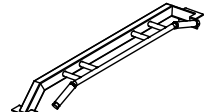
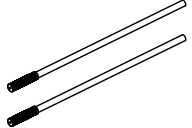
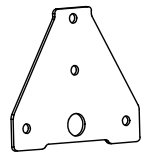
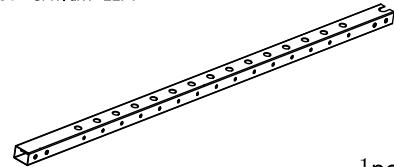
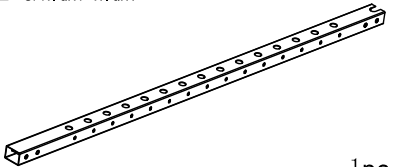
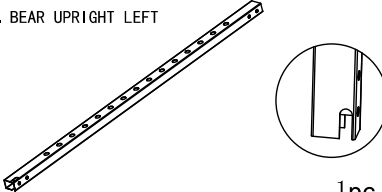
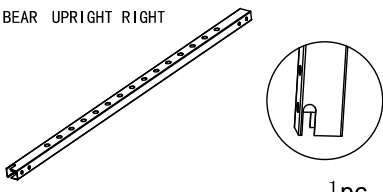
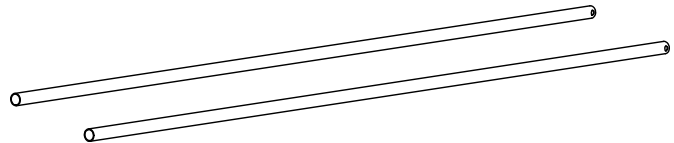

7. When the equipment is fully assembled check all the functions for correct operation. Consult the manual if you experience any issues, or for further help please contact our service department.

8. **Please regularly check if the screws are loose, and if they are, tighten them quickly.**

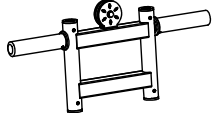
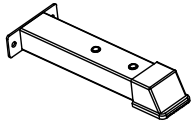
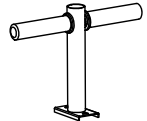

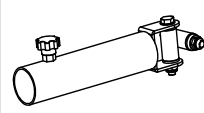
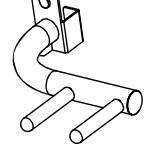
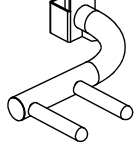
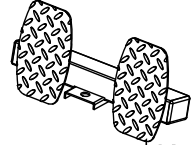
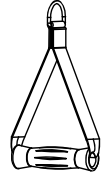
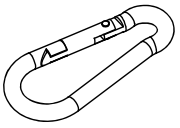
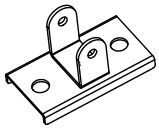
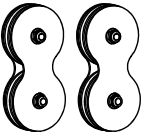
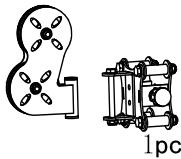
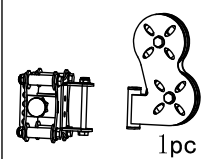
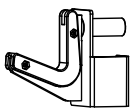
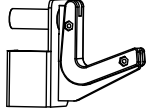
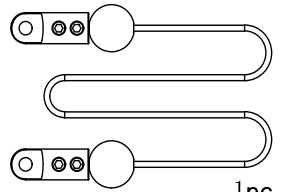
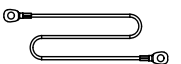
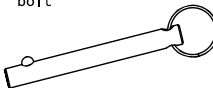
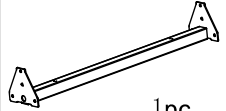
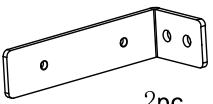

PARTS LIST

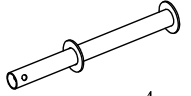
A1. BASE LEFT  1pc	A2. BASE RIGHT  1pc	B. BEAR CROSS BASE  1pc	C. UPPER CROSS FRAME  1pc
D1. D2. UPPER FRAME  1pc	E. PULL-UP FRAME  1pc	W. BAR CATCH  1pairs	V. FIXED PIECE  14pc
G1. UPRIGHT LEFT  1pc		G2. UPRIGHT RIGHT  1pc	
G3. BEAR UPRIGHT LEFT  1pc	G4. BEAR UPRIGHT RIGHT  1pc	H. GUIDE ROD (LONG)  1pairs	
I. SHOCK PAD  1pairs	J. WEIGHT FRAME  1pc	K1. WEIGHT STORAGE RACK BASE  1pc	K2. WEIGHT STORAGE RACK  1pc

PARTS LIST

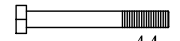
L. ROTATING TUBE GROUP  1pc	M1. HANDLEBAR LEFT  1pc	M2. HANDLEBAR RIGHT  1pc	N. PEDALS  1pc
O. CABLE HANDLEBAR  2pc	P. CLIP  2pc	Q. CONNECT GROUP U  1pc	S. MOVING PULLEY  2pc
R1. PULLEY SLIDING SLEEVE LEFT  1pc	R2. PULLEY SLIDING SLEEVE RIGHT  1pc	X1. J HOOK LEFT  1pc	X2. J HOOK RIGHT  1pc
T. CABLE A  1pc	U. CABLE B  2pc	AC. Single bead ring bolt  4pc	
F. REINFORCING PIPE GROUP  1pc	Z. ACRYLIC PLATE FIXING PIECE  2pc	Y. ACRYLIC PLATE  1pc	AB. PART 2 GROUP  4pc

HARDWARE LIST

Note: pulleys and screws are pre-installed on fittings	1. BOLT (M10*90)  44pc	2. BOLT (M5*8)  8pc	3. BOLT (M10*20)  10pc
	4. WASHER (M10)  102pc	5. WASHER (M10)  48pc	

STEP1.

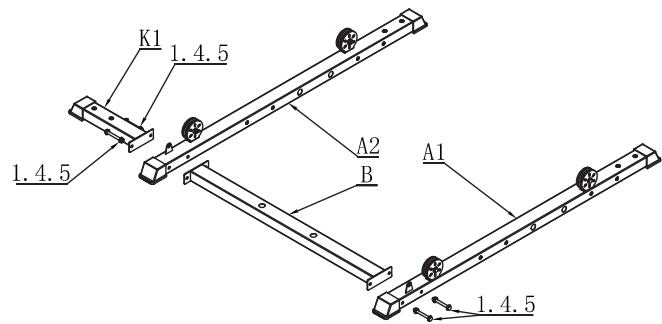

STEP2.

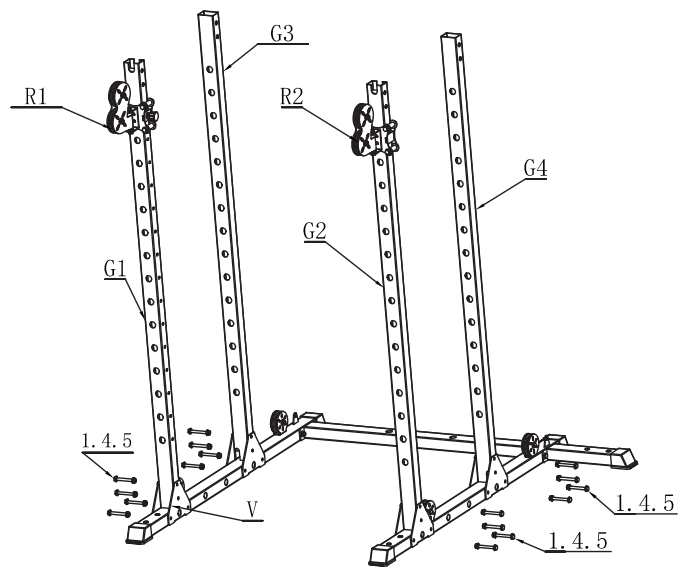

STEP3.

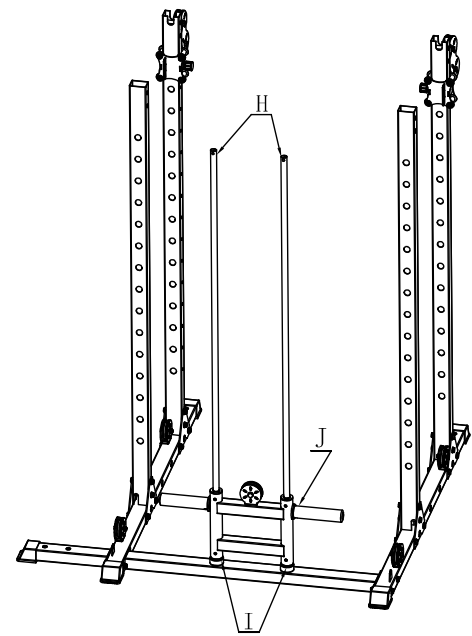

STEP4.

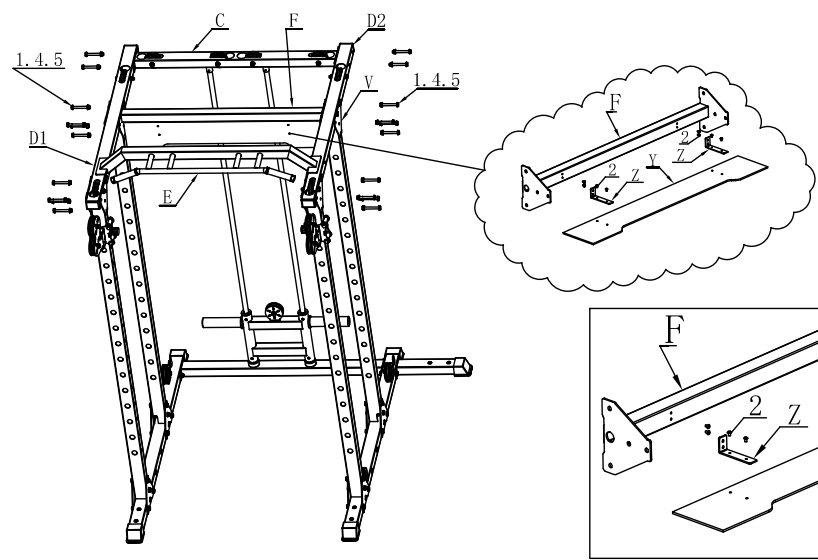

STEP5.

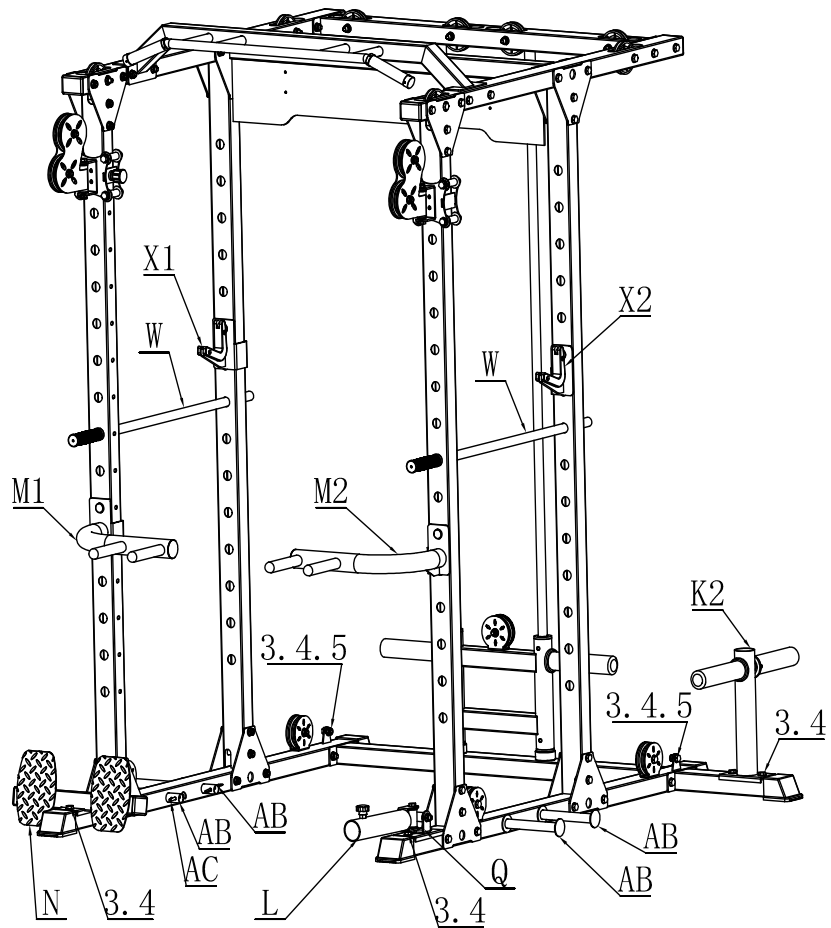

STEP6.

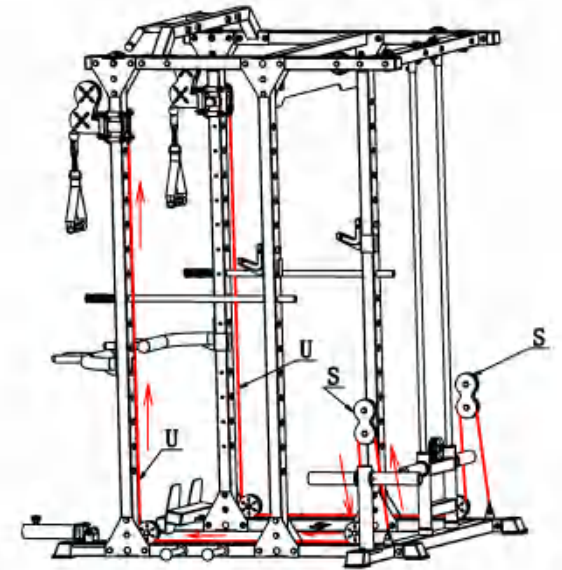
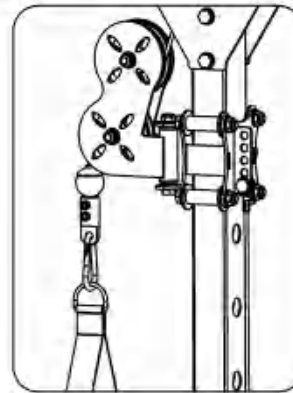

STEP7.

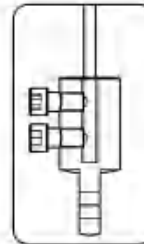

The rope must be locked tightly to prevent it from falling off

