



Maximum Stroke 800mm Maximum Speed 2000mm/s Motor Output 100W Belt width 9mm Linear Guide 24x8.5-1piece

Model representation method

YCB5 - X40 - S100 - BM - P100W - B - C 4 - 0001

Model	Stroke 50-800mm (interval 50mm-pitch)	Motor Position	The horse spreading model and power	Home Sensor	Limit Sensor
Clean Belt		BW Motor in the upper BM Motor in the side	F: Fuji 100W H: silver / M: mitsubishi / P: panasonic / S: sanyo T: Delta Y: yankawa	Out Sid C Motor Side D Opposite Motor Side SENSOR E NO SENSOR	Out Sid 3 1pc 4 2pc SENSOR 5 NO SENSOR

Brake: (if there is no brake, it will not be displayed)

Special Order No

Specification

performance	Repeatability (mm)	±0.04		
	Lead(mm)	40		
	Mlaximum Speeo (mm)	2000		
	Mlaximum Payload	Horizontal(kg)	3	
		Vertical(kg)	3	
	Rateu Thrust(N)	42		
Stroke PitchH(mm)	50-800mm/50Interval			
Parts	Available Motor Output (W)	100W,42M,200W,57M,400W		
	Bell Witd(mm)	9		
	High Rigidity Linear(mm)	W24XH8.5		
	Home Sensor	Outsioe	EE-SX672(NPN)	

Sensor Layout(Origin and endpoints)

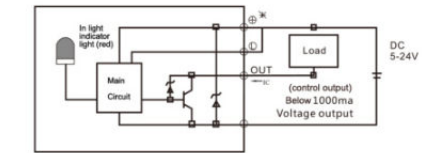

Permissible load force distance table N.m

(unit : mm)

Horizontal installation	A	B	C
2kg	323	61	112
3kg	208	39	72

(unit : mm)

Wall installation	A	B	C
2kg	105	57	303
3kg	67	36	195

Horizontal use (unit : N.m)

MY	16(N.m)
MP	20(N.m)
MR	19(N.m)

Motor installation schedule

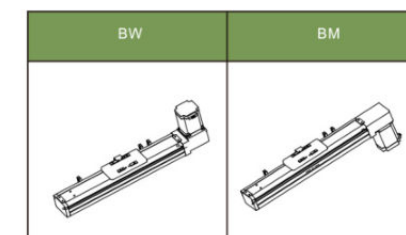

YCB5 Series

Motor in the upper/Motor in the side

BW Motor in the upper

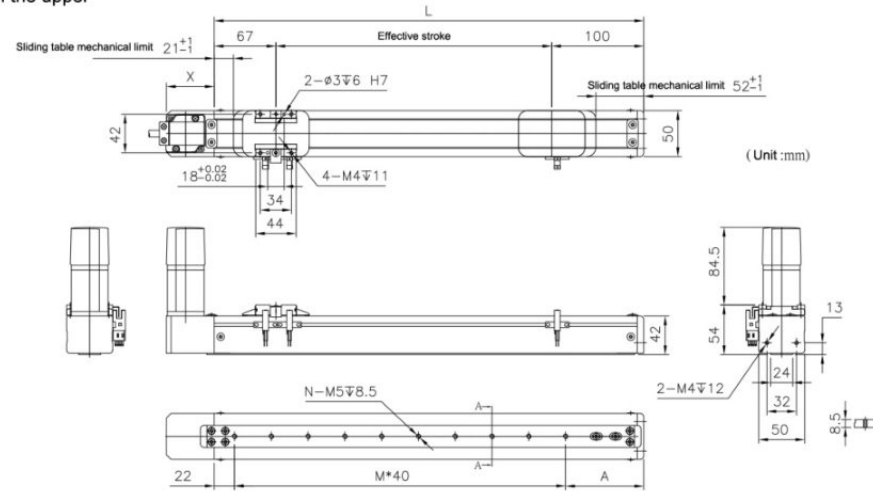

Effective stroke	50	100	150	200	250	300	350	400	450	500	550	600	650	700	750	800
L	217	267	317	367	417	467	517	567	617	667	717	767	817	867	917	967
A	75	85	95	65	75	85	95	65	75	85	95	65	75	85	95	65
M	3	4	5	7	8	9	10	12	13	14	15	17	18	19	20	22
N	4	5	6	8	9	10	11	13	14	15	16	18	19	20	21	23
KG	2.1	2.2	2.3	2.4	2.5	2.7	2.8	2.8	3	3.1	3.2	3.3	3.4	3.5	3.6	3.7

BM Motor in the side

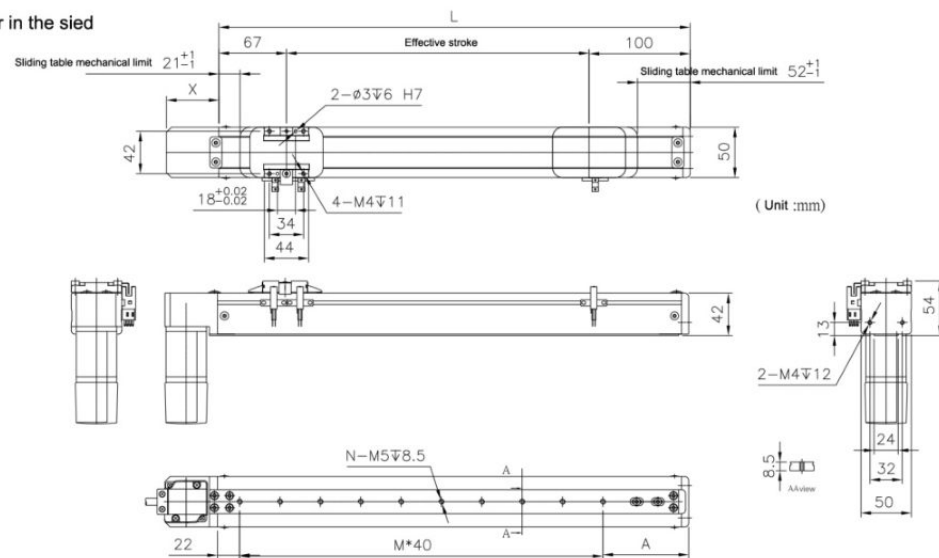

Effective stroke	50	100	150	200	250	300	350	400	450	500	550	600	650	700	750	800
L	217	267	317	367	417	467	517	567	617	667	717	767	817	867	917	967
A	75	85	95	65	75	85	95	65	75	85	95	65	75	85	95	65
M	3	4	5	7	8	9	10	12	13	14	15	17	18	19	20	22
N	4	5	6	8	9	10	11	13	14	15	16	18	19	20	21	23
KG	2.1	2.2	2.3	2.4	2.5	2.7	2.8	2.8	3	3.1	3.2	3.3	3.4	3.5	3.6	3.7

YCB6 Series

Belt Drive

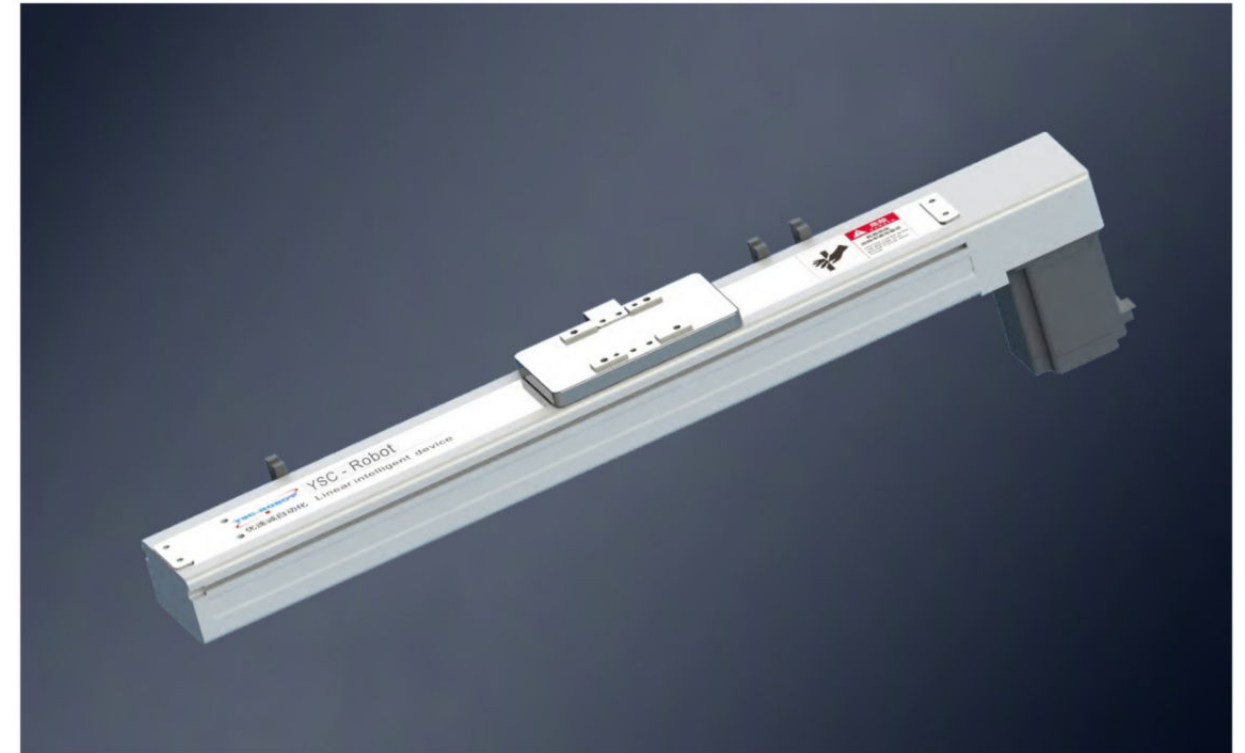

Maximum Stroke	800mm	Maximum Speed	2000mm/s	Motor Output	100W	Belt width	12mm	Linear Guide	42x9.5-1piece
----------------	-------	---------------	----------	--------------	------	------------	------	--------------	---------------

Model representation method

YCB6 - X40 - S100 - BW - P100W - B - C4 - M5 - 0001

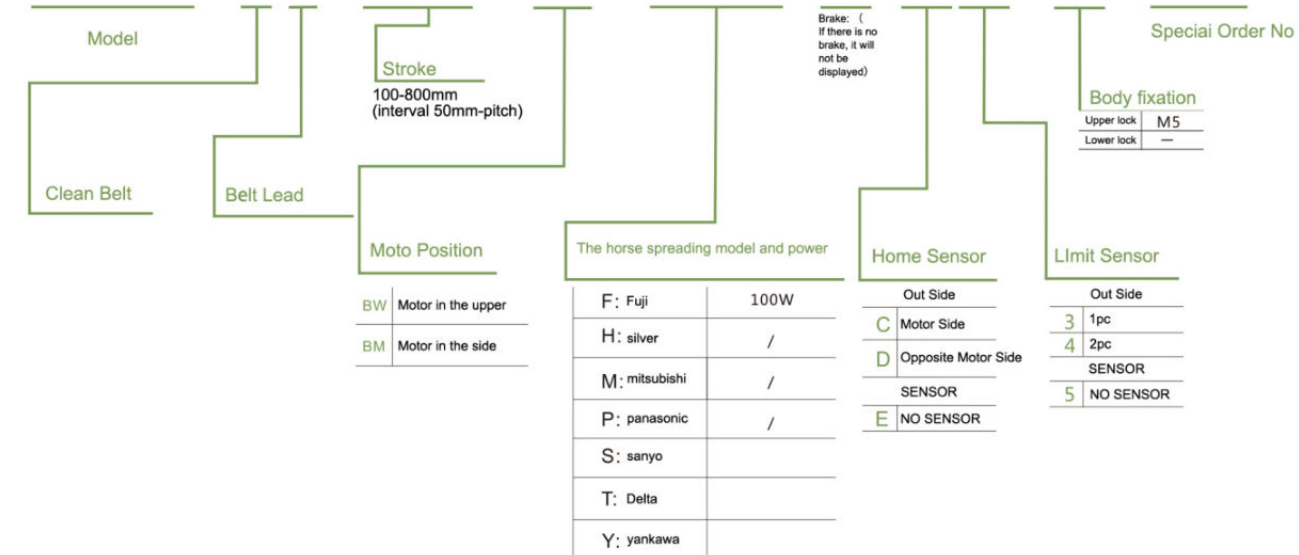

*L: The total length will vary according to the motor model, and the actual length will be based on 3D.

Specification

performance	Repeatability (mm)	±0.04		
	Lead(mm)	40		
	Maximum Speed (mm)	2000		
	Maximum Payload	Horizontal(kg)	5	
		Vertical(kg)	5	
	Rate Thrust(N)	42		
Stroke Pitch(mm)	100-800mm/50Interval			
Parts	Available Motor Output (W)	100W,42M,200W,57M,400W		
	Bell Width(mm)	12		
	High Rigidity Linear(mm)	W42XH9.5		
	Home Sensor	Outside	EE-SX672(NPN)	

Sensor Layout(Origin and endpoints)

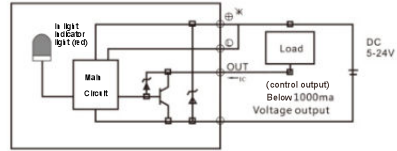

Permissible load force distance table N.m

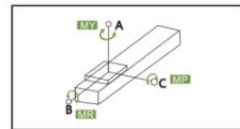
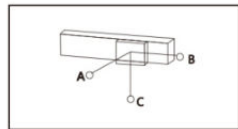
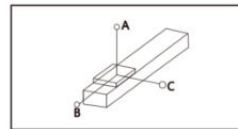

(unit : mm)

Horizontal installation	A	B	C
2kg	520	150	254
3kg	340	97	165

(unit : mm)

Wall installation	A	B	C
2kg	238	140	488
3kg	155	91	319

Horizontal use (unit : mm)

MY	70(N.m)
MP	80(N.m)
MR	75(N.m)

Motor installation schedule

BW	BM

Service hotline|0769-81388693 official website|www.ysczd.com

BW Motor in the upper

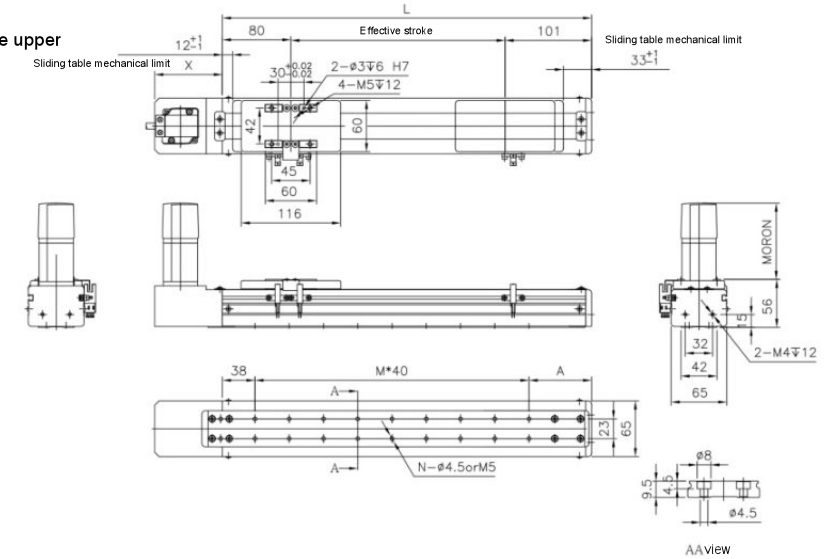

Effective stroke	100	150	200	250	300	350	400	450	500	550	600	650	700	750	800
L	281	331	381	431	481	531	581	631	681	731	781	831	881	931	981
A	83	93	63	73	83	93	63	73	83	93	63	73	83	93	63
M	4	5	7	8	9	10	12	13	14	15	17	18	19	20	22
N	10	12	16	18	20	22	26	28	30	32	36	38	40	42	46
KG	2.5	2.6	2.8	3	3.3	3.4	3.5	3.7	3.9	4.1	4.2	4.4	4.6	4.8	4.9

BM Motor in the Side

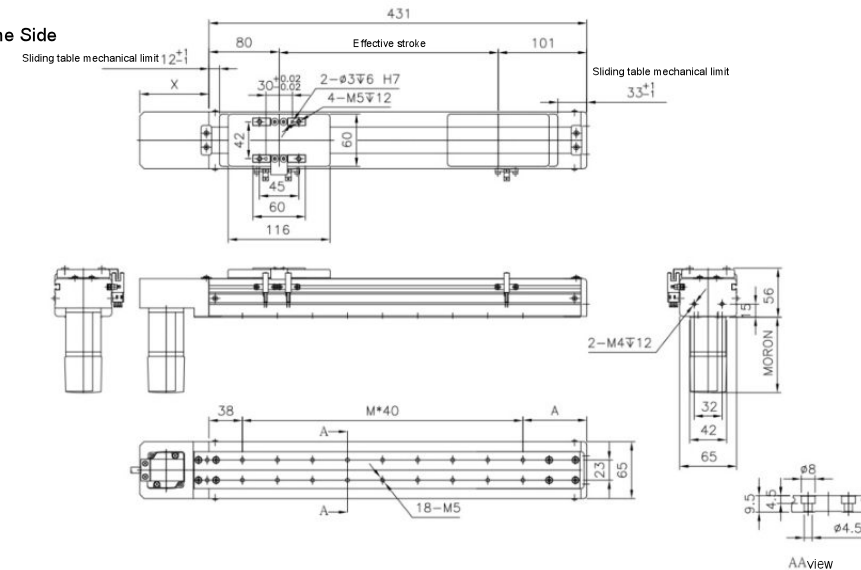

Effective stroke	100	150	200	250	300	350	400	450	500	550	600	650	700	750	800
L	281	331	381	431	481	531	581	631	681	731	781	831	881	931	981
A	83	93	63	73	83	93	63	73	83	93	63	73	83	93	63
M	4	5	7	8	9	10	12	13	14	15	17	18	19	20	22
N	10	12	16	18	20	22	26	28	30	32	36	38	40	42	46
KG	2.5	2.6	2.8	3	3.3	3.4	3.5	3.7	3.9	4.1	4.2	4.4	4.6	4.8	4.9

*L:The total length will vary according to the motor model, and the actual length will be based on 3D.



Maximum Stroke	2550mm	Maximum Speed	1600mm/s	Motor Output	100W	Belt width	15mm	Linear Guide	20x18-1 piece
----------------	--------	---------------	----------	--------------	------	------------	------	--------------	---------------

Model representation method

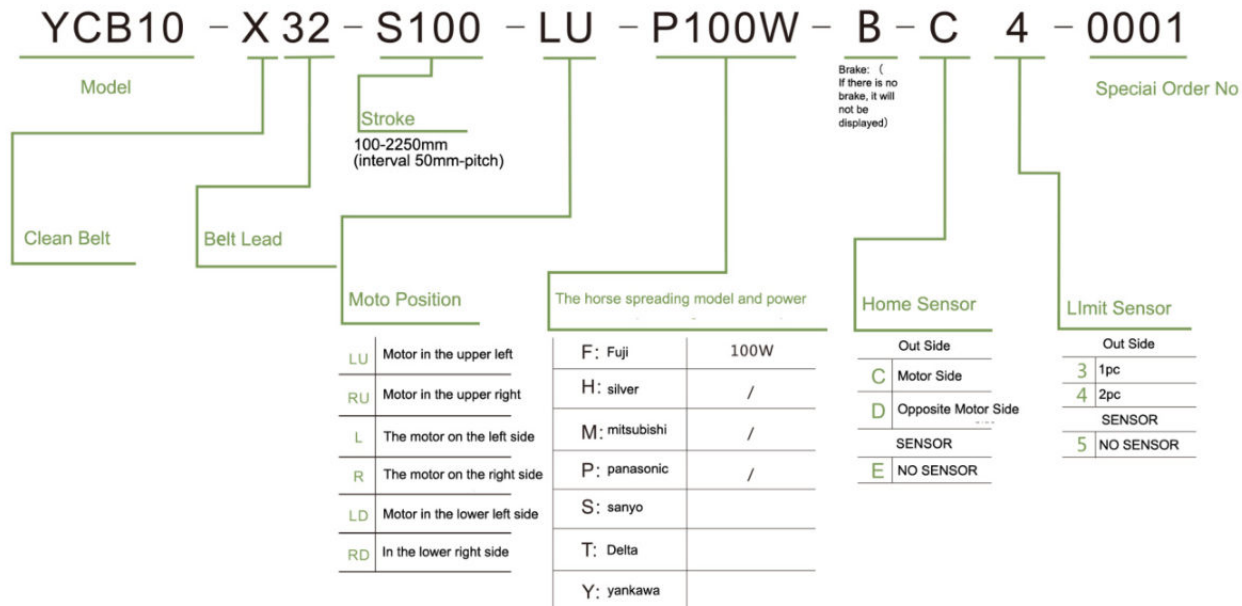

Specification

performance	Repeatability (mm)	±0.04		
	Lead(mm)	32		
	Maximum Speed (mm)	1600		
	Maximum Payload	Horizontal(kg)	10	
		Vertical(kg)	-	
	Rate Thrust(N)	61		
Stroke Pitch(mm)	100-2550mm/50interval			
Parts	Available Motor Output (W)	100W,42M,200W,57M,400W		
	Belt Width(mm)	15		
	High Rigidity Linear(mm)	W20XH18		
	Home Sensor	Outsioe	EE-SX672(NPN)	

Sensor Layout(Origin and endpoints)

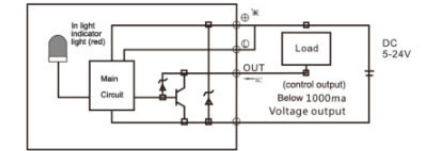

Permissible load force distance table N.m

(unit : mm)				(unit : mm)				Horizontal use (unit : N.m)	
Horizontal installation	A	B	C	Wall installation	A	B	C	MY	110(N.m)
5kg	495	152	128	4kg	162	192	625	MP	110(N.m)
8kg	301	91	77	7kg	89	106	347	MR	120(N.m)
10kg	236	71	60	10kg	60	71	236		

Motor installation schedule

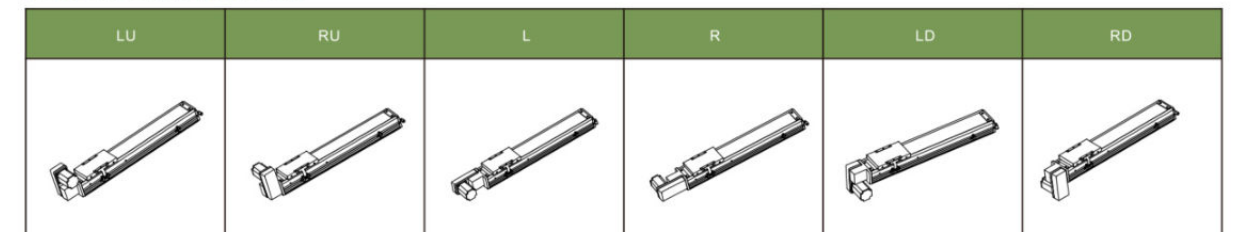

LU Motor in the upper left

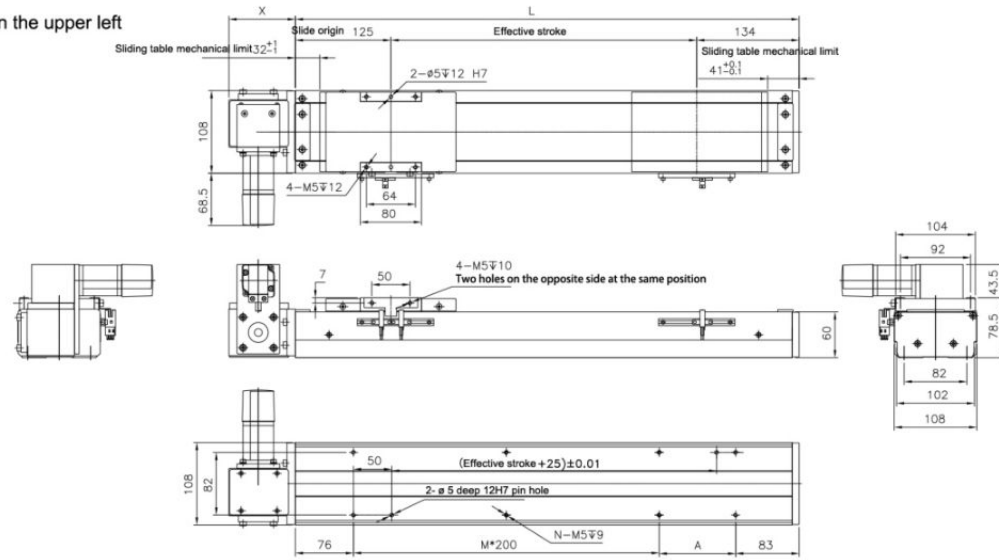

Effective stroke	100	150	200	250	300	350	400	450	500	550	600	650	700	750	800	850	900	950	1000	1050	1100	1150	1200	1250	1300
L	359	409	459	509	559	609	659	709	759	809	859	909	959	1009	1059	1109	1159	1209	1259	1309	1359	1409	1459	1509	1559
A	200	50	100	150	200	50	100	150	200	50	100	150	200	50	100	150	200	50	100	150	200	50	100	150	200
M	0	1	1	1	1	2	2	2	2	3	3	3	3	4	4	4	4	5	5	5	5	6	6	6	6
N	4	6	6	6	6	8	8	8	8	10	10	10	10	12	12	12	12	14	14	14	14	16	16	16	16
KG	8.3	8.73	9.15	9.57	10	10.42	10.84	11.26	11.69	12.11	12.53	12.96	13.38	13.8	14.23	14.65	15.07	15.49	15.92	16.34	16.76	17.18	17.6	18.02	18.44

RU Motor in the upper right

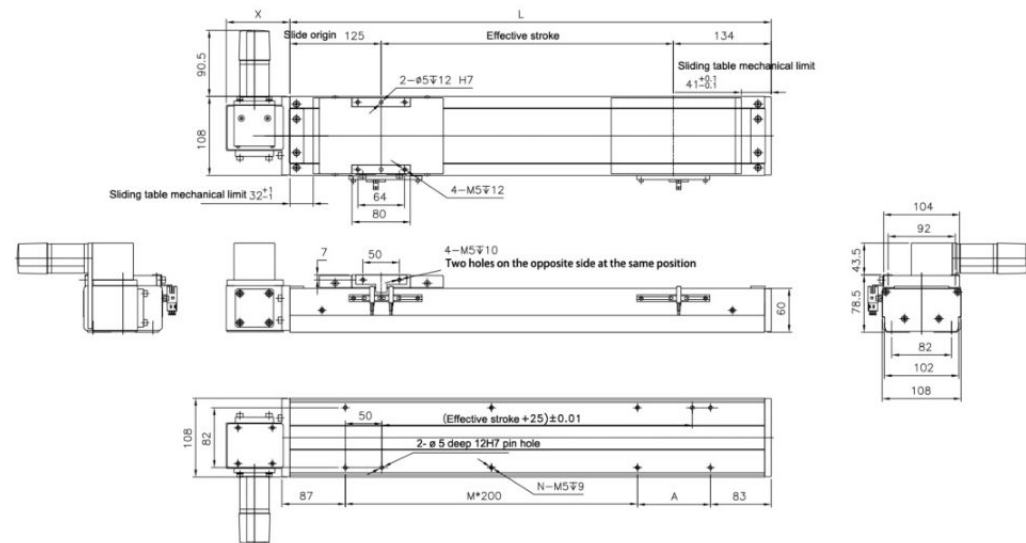

Effective stroke	100	150	200	250	300	350	400	450	500	550	600	650	700	750	800	850	900	950	1000	1050	1100	1150	1200	1250	1300
L	359	409	459	509	559	609	659	709	759	809	859	909	959	1009	1059	1109	1159	1209	1259	1309	1359	1409	1459	1509	1559
A	200	50	100	150	200	50	100	150	200	50	100	150	200	50	100	150	200	50	100	150	200	50	100	150	200
M	0	1	1	1	1	2	2	2	2	3	3	3	3	4	4	4	4	5	5	5	5	6	6	6	6
N	4	6	6	6	6	8	8	8	8	10	10	10	10	12	12	12	12	14	14	14	14	16	16	16	16
KG	8.3	8.73	9.15	9.57	10	10.42	10.84	11.26	11.69	12.11	12.53	12.96	13.38	13.8	14.23	14.65	15.07	15.49	15.92	16.34	16.76	17.18	17.6	18.02	18.44

L The motor on the left side

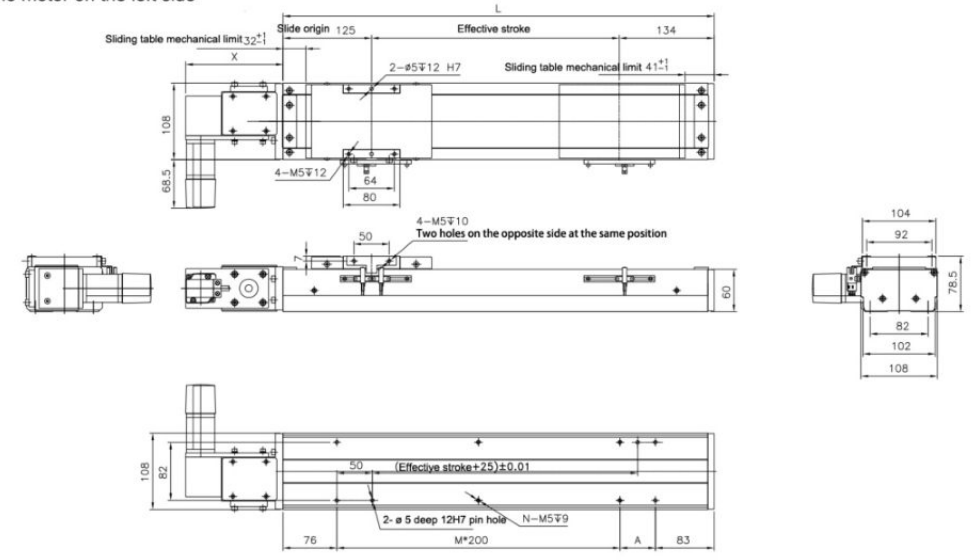

Effective stroke	100	150	200	250	300	350	400	450	500	550	600	650	700	750	800	850	900	950	1000	1050	1100	1150	1200	1250	1300
L	359	409	459	509	559	609	659	709	759	809	859	909	959	1009	1059	1109	1159	1209	1259	1309	1359	1409	1459	1509	1559
A	200	50	100	150	200	50	100	150	200	50	100	150	200	50	100	150	200	50	100	150	200	50	100	150	200
M	0	1	1	1	1	2	2	2	2	3	3	3	3	4	4	4	4	5	5	5	5	6	6	6	6
N	4	6	6	6	6	8	8	8	8	10	10	10	10	12	12	12	12	14	14	14	14	16	16	16	16
KG	8.3	8.73	9.15	9.57	10	10.42	10.84	11.26	11.69	12.11	12.53	12.96	13.38	13.8	14.23	14.65	15.07	15.49	15.92	16.34	16.76	17.18	17.6	18.02	18.44

R The motor on the right side

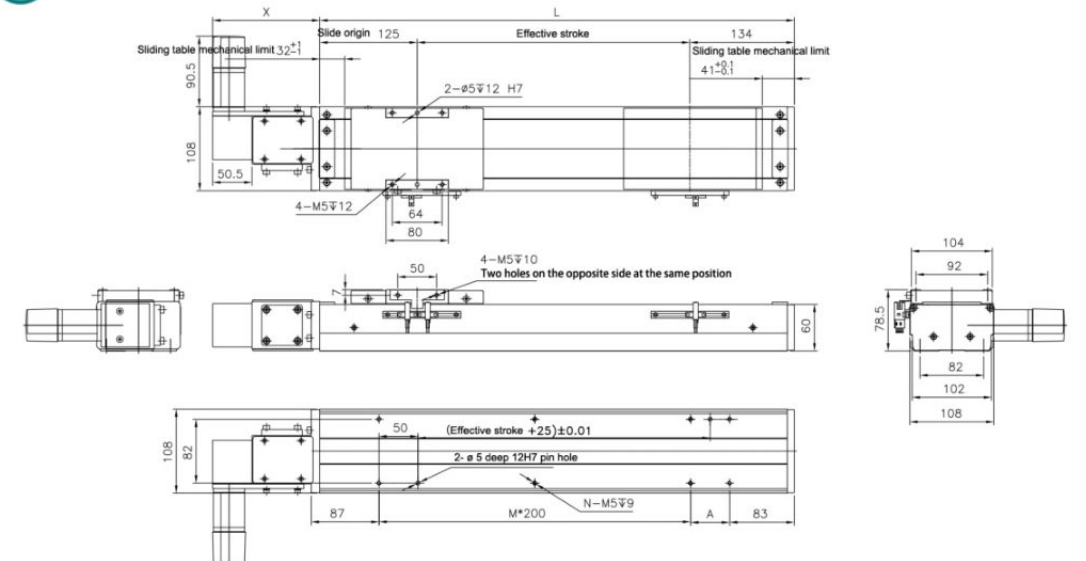

Effective stroke	100	150	200	250	300	350	400	450	500	550	600	650	700	750	800	850	900	950	1000	1050	1100	1150	1200	1250	1300
L	359	409	459	509	559	609	659	709	759	809	859	909	959	1009	1059	1109	1159	1209	1259	1309	1359	1409	1459	1509	1559
A	200	50	100	150	200	50	100	150	200	50	100	150	200	50	100	150	200	50	100	150	200	50	100	150	200
M	0	1	1	1	1	2	2	2	2	3	3	3	3	4	4	4	4	5	5	5	5	6	6	6	6
N	4	6	6	6	6	8	8	8	8	10	10	10	10	12	12	12	12	14	14	14	14	16	16	16	16
KG	8.3	8.73	9.15	9.57	10	10.42	10.84	11.26	11.69	12.11	12.53	12.96	13.38	13.8	14.23	14.65	15.07	15.49	15.92	16.34	16.76	17.18	17.6	18.02	18.44

*L: The total length will vary according to the motor model, and the actual length will be based on 3D.

*L: The total length will vary according to the motor model, and the actual length will be based on 3D.

YCB10 Series

Motor in the lower left side/In the lower right side

LD Motor in the lower left side

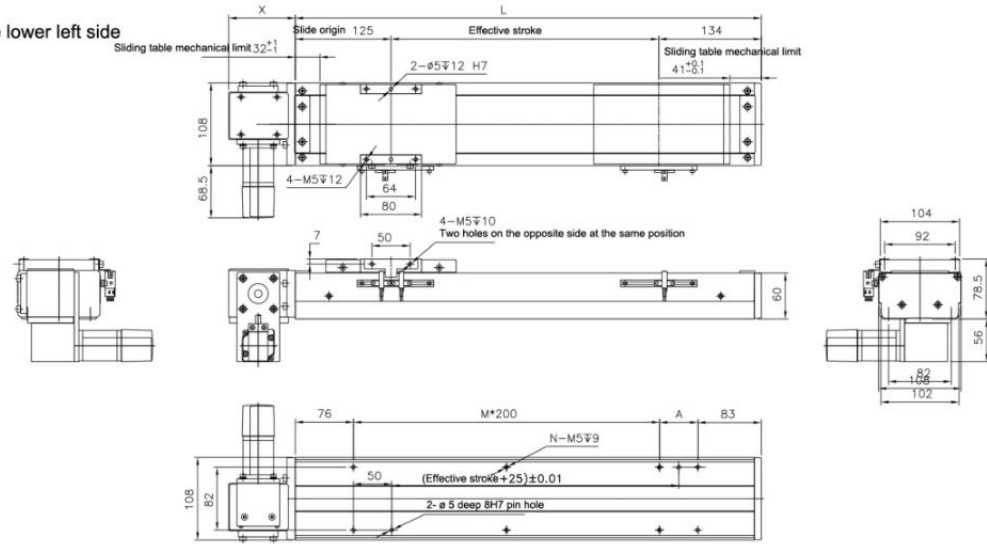

Effective stroke	100	150	200	250	300	350	400	450	500	550	600	650	700	750	800	850	900	950	1000	1050	1100	1150	1200	1250	1300
L	359	409	459	509	559	609	659	709	759	809	859	909	959	1009	1059	1109	1159	1209	1259	1309	1359	1409	1459	1509	1559
A	200	50	100	150	200	50	100	150	200	50	100	150	200	50	100	150	200	50	100	150	200	50	100	150	200
M	0	1	1	1	1	2	2	2	2	3	3	3	3	4	4	4	4	5	5	5	5	6	6	6	6
N	4	6	6	6	6	8	8	8	8	10	10	10	10	12	12	12	12	14	14	14	14	16	16	16	16
KG	8.3	8.73	9.15	9.57	10	10.42	10.84	11.26	11.69	12.11	12.53	12.96	13.38	13.8	14.23	14.65	15.07	15.49	15.92	16.34	16.76	17.18	17.6	18.02	18.44

RD In the lower right side

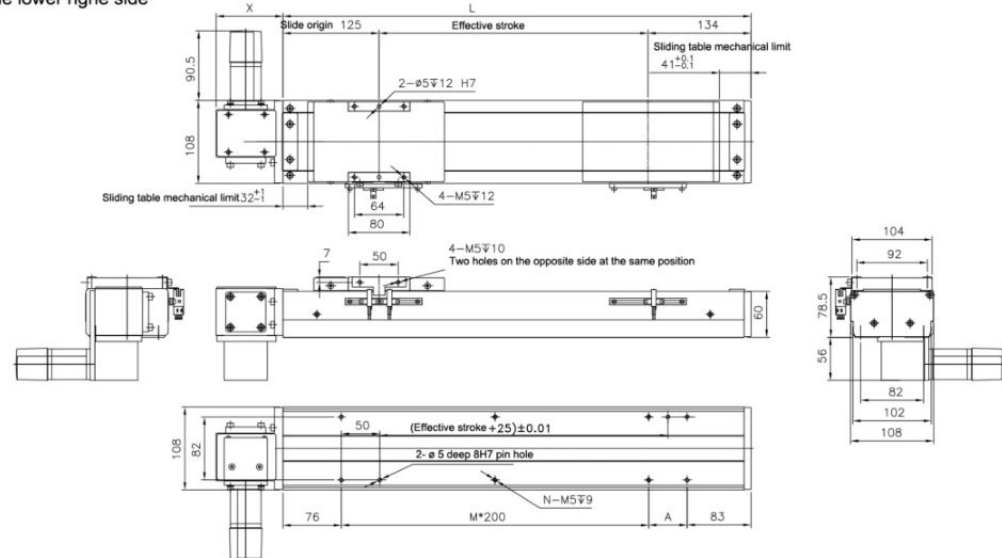

Effective stroke	100	150	200	250	300	350	400	450	500	550	600	650	700	750	800	850	900	950	1000	1050	1100	1150	1200	1250	1300
L	359	409	459	509	559	609	659	709	759	809	859	909	959	1009	1059	1109	1159	1209	1259	1309	1359	1409	1459	1509	1559
A	200	50	100	150	200	50	100	150	200	50	100	150	200	50	100	150	200	50	100	150	200	50	100	150	200
M	0	1	1	1	1	2	2	2	2	3	3	3	3	4	4	4	4	5	5	5	5	6	6	6	6
N	4	6	6	6	6	8	8	8	8	10	10	10	10	12	12	12	12	14	14	14	14	16	16	16	16
KG	8.3	8.73	9.15	9.57	10	10.42	10.84	11.26	11.69	12.11	12.53	12.96	13.38	13.8	14.23	14.65	15.07	15.49	15.92	16.34	16.76	17.18	17.6	18.02	18.44

*L: The total length will vary according to the motor model, and the actual length will be based on 3D.

YCB13 Series

Belt Drive

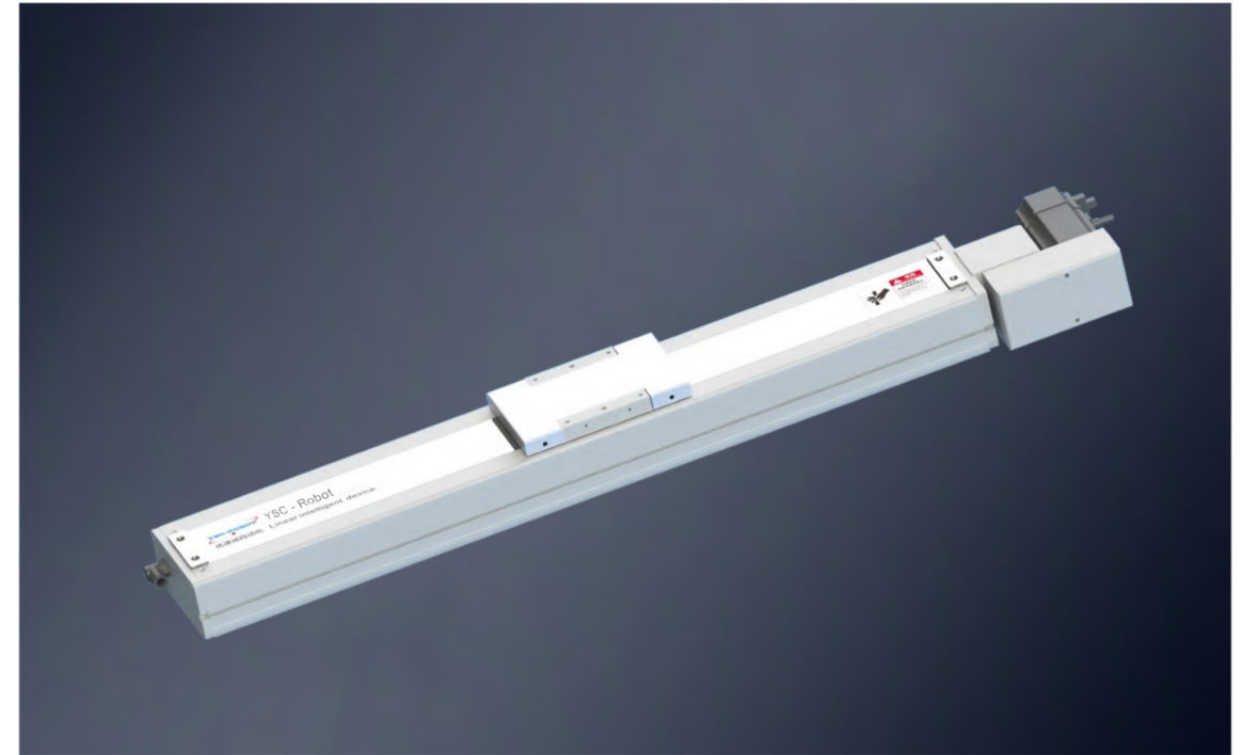

Maximum Stroke	3050mm	Maximum Speed	2500mm/s	Motor Output	200W	Belt width	22mm	Linear Guide	15x12.5-2pieces
----------------	--------	---------------	----------	--------------	------	------------	------	--------------	-----------------

Model representation method

YCB13 - X50 - S100 - LU - P200W - B - C 4 - 0001

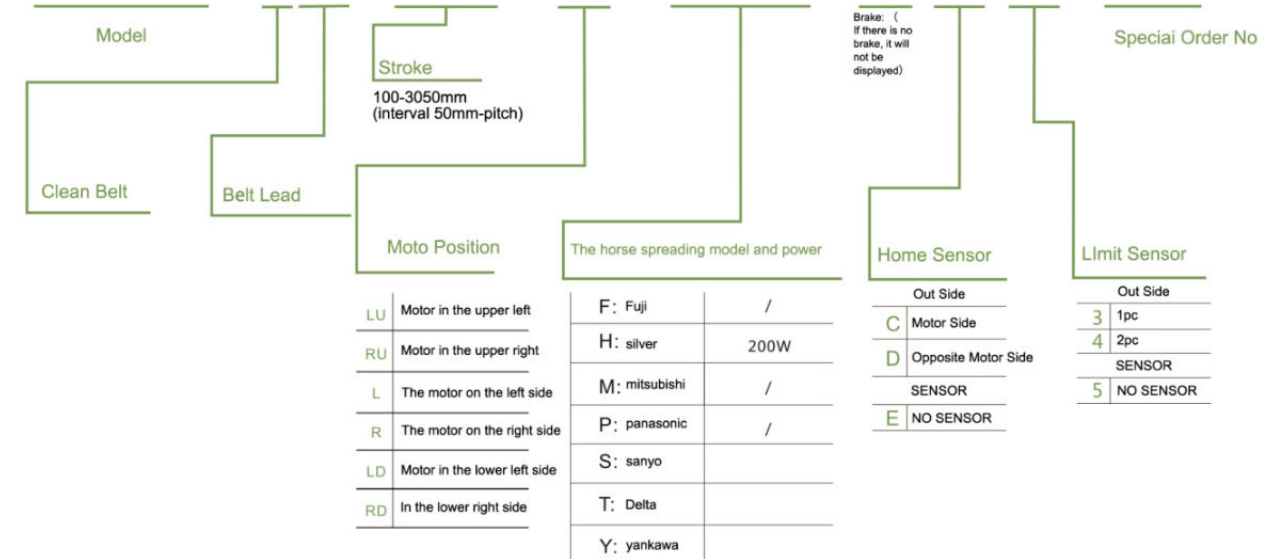

Specification

performance	Repeatability (mm)	±0.04	
	Lead(mm)	50	
	Maximum Speed (mm)	2500	
	Maximum Payload	Horizontal(kg)	25
		Vertical(kg)	
	Rate Thrust(N)	100	
Stroke Pitch(mm)	100-3050mm/50interval		
Parts	Available Motor Output (W)	100W,42M,200W,57M,400W	
	Bell Width(mm)	22	
	High Rigidity Linear(mm)	W15XH12.5	
	Home Sensor	Outside	EE-SX672(NPN)

Sensor Layout(Origin and endpoints)

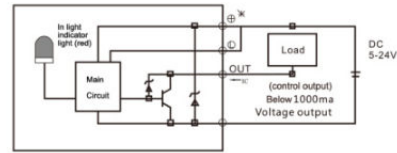

Permissible load force distance table N.m

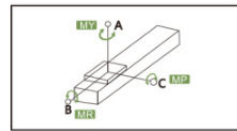
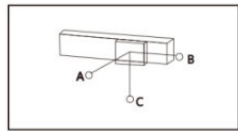
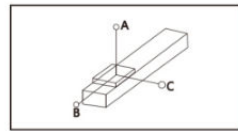

(unit : mm)

Horizontal installation	A	B	C
10kg	1794	688	583
20kg	858	324	253
25kg	670	251	197

(unit : mm)

Wall installation	A	B	C
15kg	348	446	1170
18kg	285	365	960
25kg	197	251	670

Horizontal use (unit : N.m)

MY	551(N.m)
MP	552(N.m)
MR	485(N.m)

Motor installation schedule

LU	RU	L	R	LD	RD

Motor in the upper left/Motor in the upper right

LU Motor in the upper left

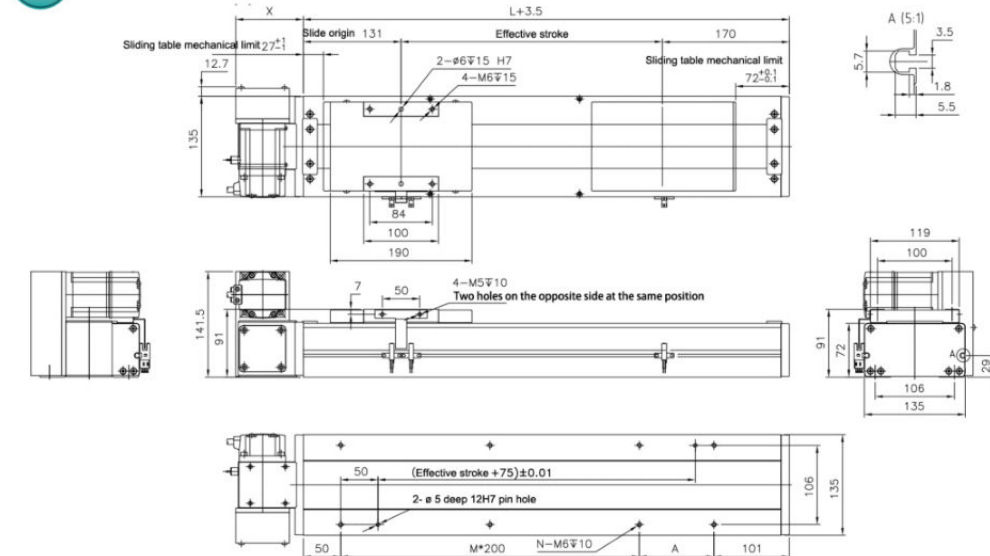

Effective stroke	100	150	200	250	300	350	400	450	500	550	600	650	700	750	800	850	900	950	1000	1050	1100	1150	1200	1250	1300	1350	1400	1450	1500	1550
L	401	451	501	551	601	651	701	751	801	851	901	951	1001	1051	1101	1151	1201	1251	1301	1351	1401	1451	1501	1551	1601	1651	1701	1751	1801	1851
A	50	100	150	200	50	100	150	200	50	100	150	200	50	100	150	200	50	100	150	200	50	100	150	200	50	100	150	200	50	100
M	1	1	1	1	2	2	2	2	3	3	3	3	4	4	4	4	5	5	5	5	6	6	6	6	7	7	7	7	8	8
N	6	6	6	6	8	8	8	8	10	10	10	10	12	12	12	12	14	14	14	14	16	16	16	16	18	18	18	18	20	20
KG	11.6	12	12.5	13	13.5	14	14.4	15	15.4	16	16.4	16.9	17.4	17.9	18.4	18.9	19.4	19.9	20.3	20.9	21.5	22.1	22.7	23.3	23.9	24.5	25.1	25.7	26.3	26.9

RU Motor in the Side

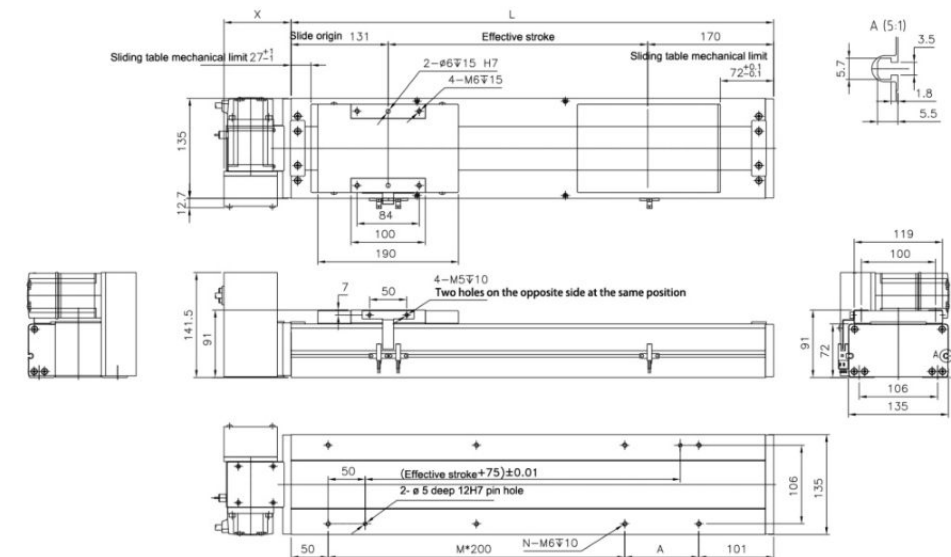

Effective stroke	100	150	200	250	300	350	400	450	500	550	600	650	700	750	800	850	900	950	1000	1050	1100	1150	1200	1250	1300	1350	1400	1450	1500	1550
L	401	451	501	551	601	651	701	751	801	851	901	951	1001	1051	1101	1151	1201	1251	1301	1351	1401	1451	1501	1551	1601	1651	1701	1751	1801	1851
A	50	100	150	200	50	100	150	200	50	100	150	200	50	100	150	200	50	100	150	200	50	100	150	200	50	100	150	200	50	100
M	1	1	1	1	2	2	2	2	3	3	3	3	4	4	4	4	5	5	5	5	6	6	6	6	7	7	7	7	8	8
N	6	6	6	6	8	8	8	8	10	10	10	10	12	12	12	12	14	14	14	14	16	16	16	16	18	18	18	18	20	20
KG	11.6	12	12.5	13	13.5	14	14.4	15	15.4	16	16.4	16.9	17.4	17.9	18.4	18.9	19.4	19.9	20.3	20.9	21.5	22.1	22.7	23.3	23.9	24.5	25.1	25.7	26.3	26.9

*L: The total length will vary according to the motor model, and the actual length will be based on 3D.

L The motor on the left side

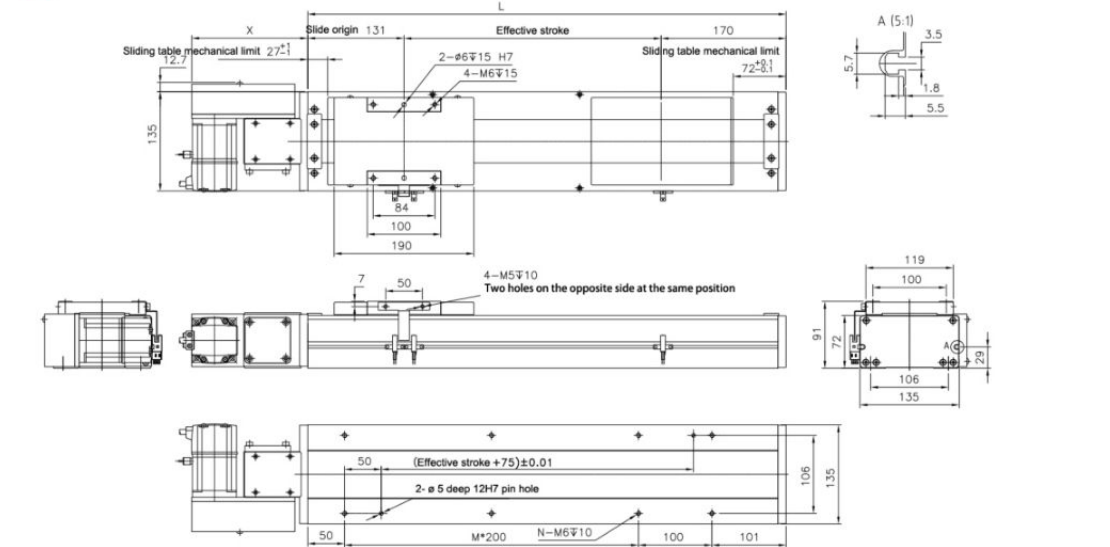

Effective stroke	100	150	200	250	300	350	400	450	500	550	600	650	700	750	800	850	900	950	1000	1050	1100	1150	1200	1250	1300	1350	1400	1450	1500	1550
L	401	451	501	551	601	651	701	751	801	851	901	951	1001	1051	1101	1151	1201	1251	1301	1351	1401	1451	1501	1551	1601	1651	1701	1751	1801	1851
A	50	100	150	200	50	100	150	200	50	100	150	200	50	100	150	200	50	100	150	200	50	100	150	200	50	100	150	200	50	100
M	1	1	1	1	2	2	2	2	3	3	3	3	4	4	4	4	5	5	5	5	6	6	6	6	7	7	7	7	8	8
N	6	6	6	6	8	8	8	8	10	10	10	10	12	12	12	12	14	14	14	14	16	16	16	16	18	18	18	18	20	20
KG	11.6	12	12.5	13	13.5	14	14.4	15	15.4	16	16.4	16.9	17.4	17.9	18.4	18.9	19.4	19.9	20.3	20.9	21.5	22.1	22.7	23.3	23.9	24.5	25.1	25.7	26.3	26.9

R The motor on the right side

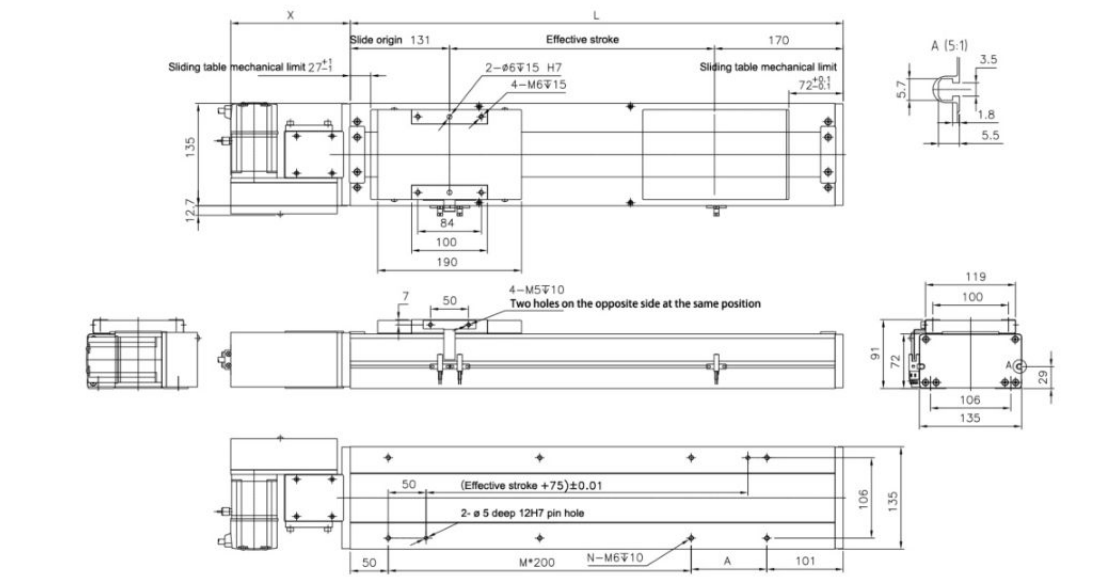

Effective stroke	100	150	200	250	300	350	400	450	500	550	600	650	700	750	800	850	900	950	1000	1050	1100	1150	1200	1250	1300	1350	1400	1450	1500	1550
L	401	451	501	551	601	651	701	751	801	851	901	951	1001	1051	1101	1151	1201	1251	1301	1351	1401	1451	1501	1551	1601	1651	1701	1751	1801	1851
A	50	100	150	200	50	100	150	200	50	100	150	200	50	100	150	200	50	100	150	200	50	100	150	200	50	100	150	200	50	100
M	1	1	1	1	2	2	2	2	3	3	3	3	4	4	4	4	5	5	5	5	6	6	6	6	7	7	7	7	8	8
N	6	6	6	6	8	8	8	8	10	10	10	10	12	12	12	12	14	14	14	14	16	16	16	16	18	18	18	18	20	20
KG	11.6	12	12.5	13	13.5	14	14.4	15	15.4	16	16.4	16.9	17.4	17.9	18.4	18.9	19.4	19.9	20.3	20.9	21.5	22.1	22.7	23.3	23.9	24.5	25.1	25.7	26.3	26.9

*L: The total length will vary according to the motor model, and the actual length will be based on 3D.

LD Motor in the lower left side

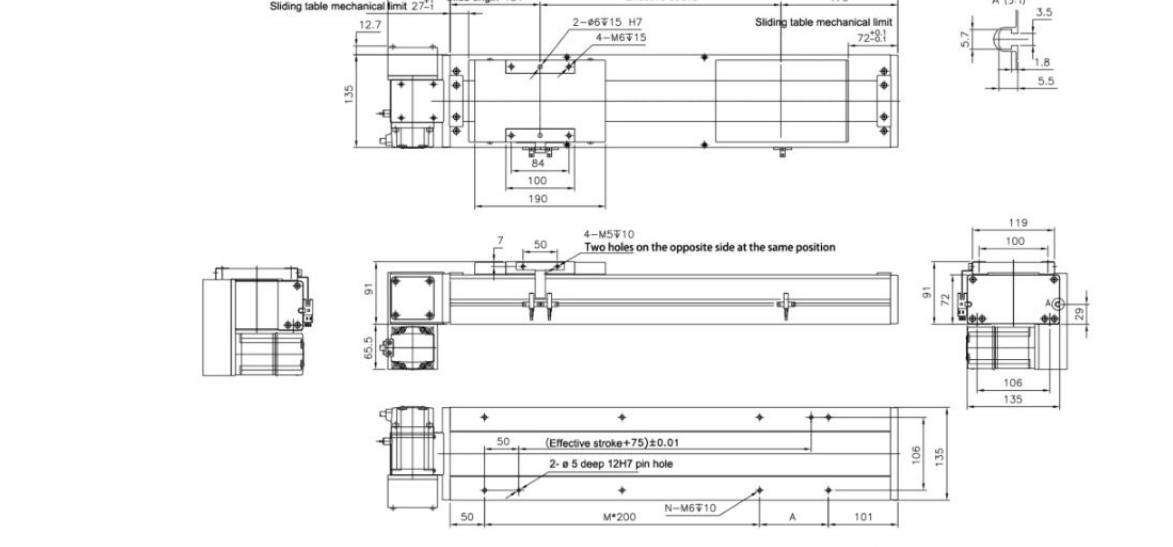

Effective stroke	100	150	200	250	300	350	400	450	500	550	600	650	700	750	800	850	900	950	1000	1050	1100	1150	1200	1250	1300	1350	1400	1450	1500	1550
L	401	451	501	551	601	651	701	751	801	851	901	951	1001	1051	1101	1151	1201	1251	1301	1351	1401	1451	1501	1551	1601	1651	1701	1751	1801	1851
A	50	100	150	200	50	100	150	200	50	100	150	200	50	100	150	200	50	100	150	200	50	100	150	200	50	100	150	200	50	100
M	1	1	1	1	2	2	2	2	3	3	3	3	4	4	4	4	5	5	5	5	6	6	6	6	7	7	7	7	8	8
N	6	6	6	6	8	8	8	8	10	10	10	10	12	12	12	12	14	14	14	14	16	16	16	16	18	18	18	18	20	20
KG	11.6	12	12.5	13	13.5	14	14.4	15	15.4	16	16.4	16.9	17.4	17.9	18.4	18.9	19.4	19.9	20.3	20.9	21.5	22.1	22.7	23.3	23.9	24.5	25.1	25.7	26.3	26.9

RD In the lower right side

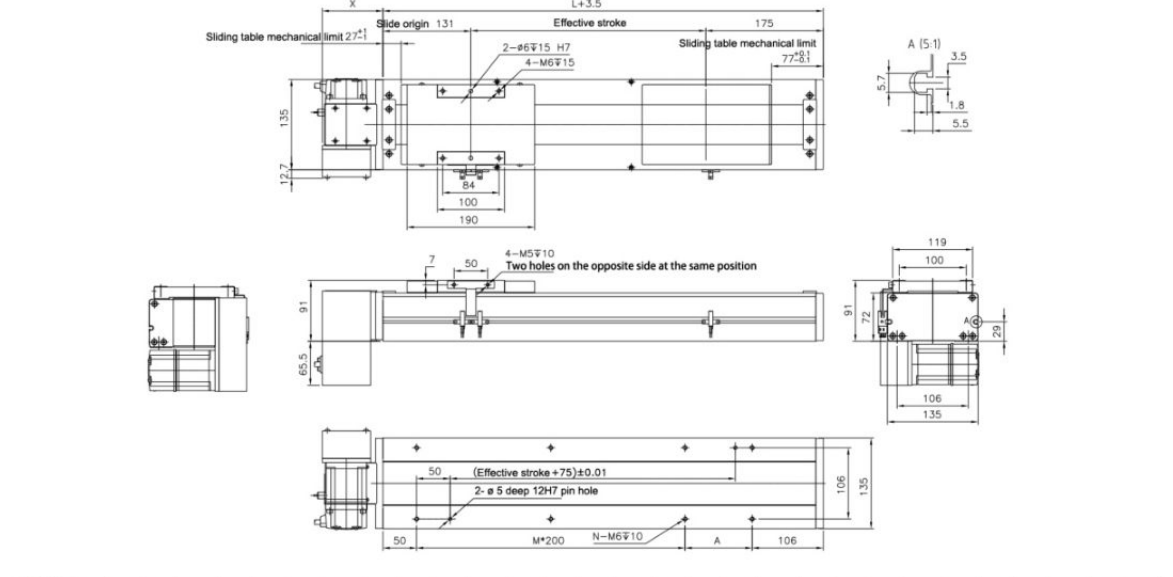

Effective stroke	100	150	200	250	300	350	400	450	500	550	600	650	700	750	800	850	900	950	1000	1050	1100	1150	1200	1250	1300	1350	1400	1450	1500	1550
L	401	451	501	551	601	651	701	751	801	851	901	951	1001	1051	1101	1151	1201	1251	1301	1351	1401	1451	1501	1551	1601	1651	1701	1751	1801	1851
A	50	100	150	200	50	100	150	200	50	100	150	200	50	100	150	200	50	100	150	200	50	100	150	200	50	100	150	200	50	100
M	1	1	1	1	2	2	2	2	3	3	3	3	4	4	4	4	5	5	5	5	6	6	6	6	7	7	7	7	8	8
N	6	6	6	6	8	8	8	8	10	10	10	10	12	12	12	12	14	14	14	14	16	16	16	16	18	18	18	18	20	20
KG	11.6	12	12.5	13	13.5	14	14.4	15	15.4	16	16.4	16.9	17.4	17.9	18.4	18.9	19.4	19.9	20.3	20.9	21.5	22.1	22.7	23.3	23.9	24.5	25.1	25.7	26.3	26.9

*L: The total length will vary according to the motor model, and the actual length will be based on 3D.

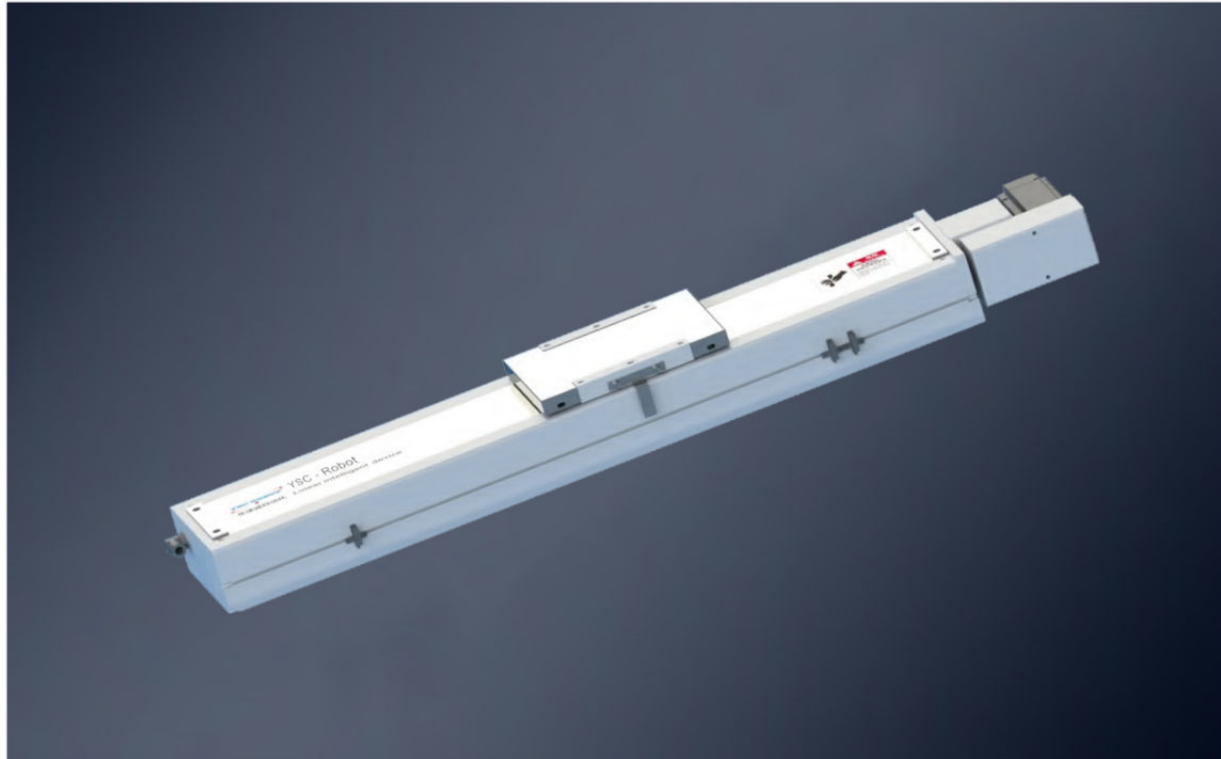

Maximum Stroke 3050mm Maximum Speed 2500mm/s Motor Output 400W Belt width 30mm Linear Guide 20x15-2piece

Model representation method

YCB17 - X50 - S500 - LU - P400W - B - C 4 - 0001

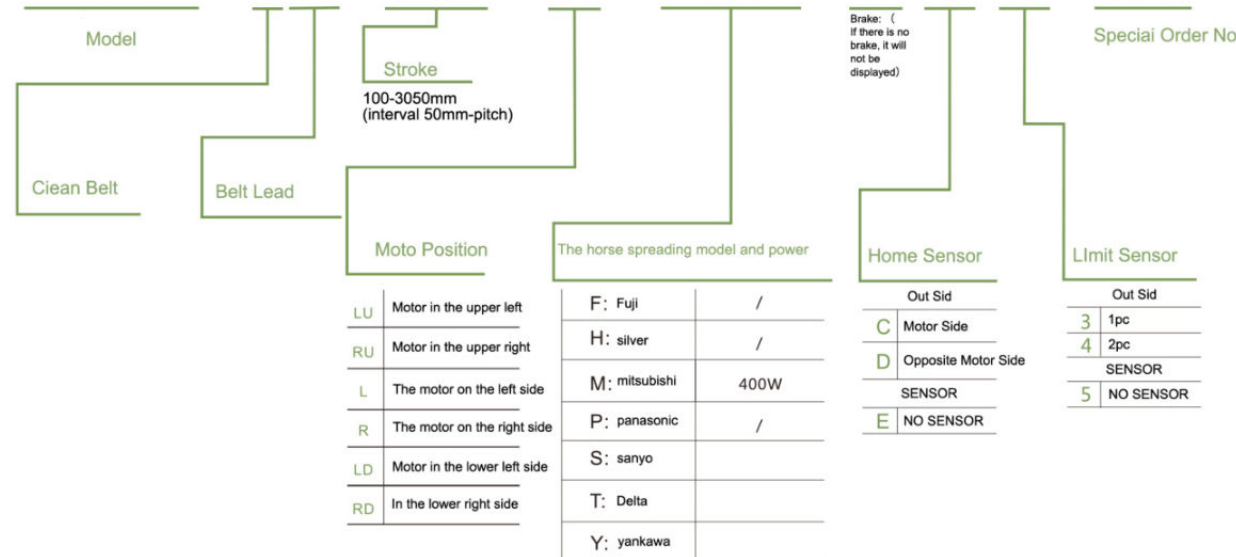

Specification

performance	Repeatability (mm)	±0.04	
	Lead(mm)	50	
	Maximum Speed (mm)	2500	
	Maximum Payload	Horizontal(kg)	45
		Vertical(kg)	
	Rate Thrust(N)	204	
Stroke Pitch(mm)	100-3050mm/50interval		
Parts	Available Motor Output (W)	400W,750W,86M,1000W	
	Belt Width(mm)	30	
	High Rigidity Linear(mm)	W20XH15	
	Home Sensor	Outside	EE-SX672(NPN)

Sensor Layout(Origin and endpoints)

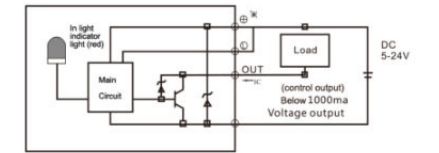

Permissible load force distance table N.m

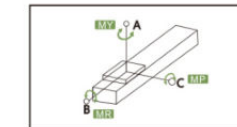
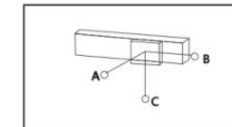
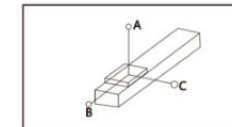

(unit : mm)

Horizontal installation	A	B	C
10kg	2942	1133	1033
20kg	1430	547	498
30kg	926	350	320
45kg	588	219	201

(unit : mm)

Wall installation	A	B	C
10kg	676	742	1933
25kg	390	428	1127
35kg	269	294	781
45kg	201	219	588

Horizontal use (unit : N.m)

MY	1032(N.m)
MP	1034(N.m)
MR	908(N.m)

Motor installation schedule

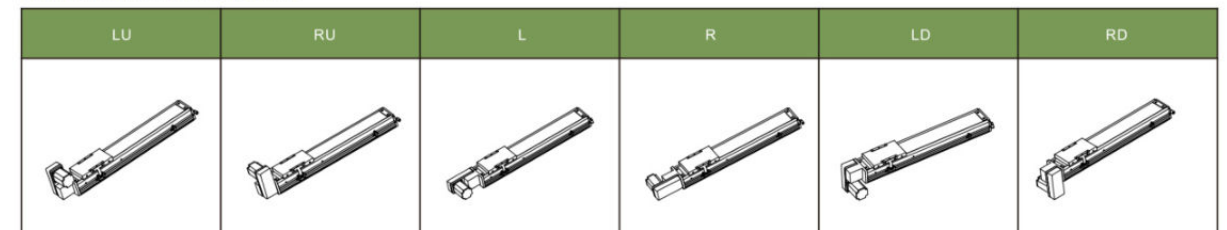

LU Motor in the upper left

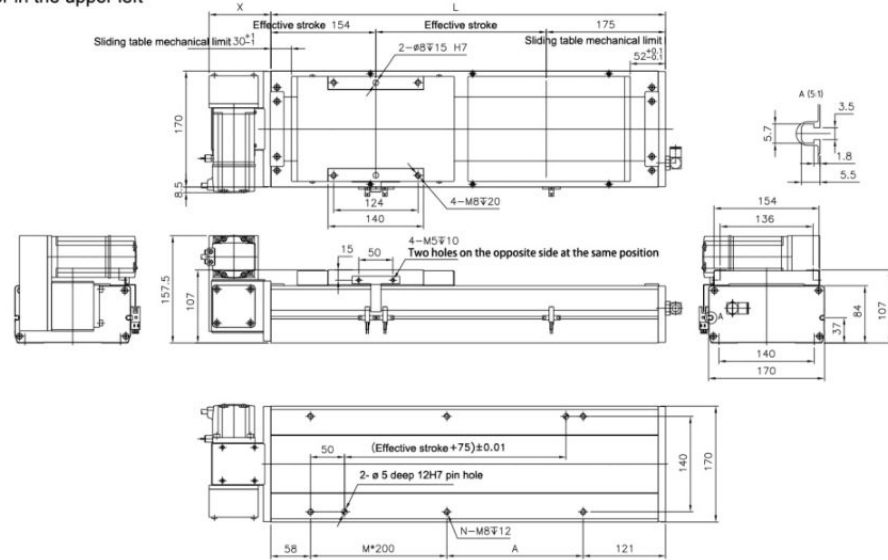

Effective stroke	100	150	200	250	300	350	400	450	500	550	600	650	700	750	800	850	900	950	1000	1050	1100	1150	1200	1250	1300	1350	1400	1450	1500	1550
L	429	479	529	579	629	679	729	779	829	879	929	979	1029	1079	1129	1179	1229	1279	1329	1379	1429	1479	1529	1579	1629	1679	1729	1779	1829	1879
A	50	100	150	200	50	100	150	200	50	100	150	200	50	100	150	200	50	100	150	200	50	100	150	200	50	100	150	200	50	100
M	1	1	1	1	2	2	2	2	3	3	3	3	4	4	4	4	5	5	5	5	6	6	6	6	7	7	7	7	8	8
N	6	6	6	6	8	8	8	8	10	10	10	10	12	12	12	12	14	14	14	14	16	16	16	16	18	18	18	18	20	20
KG	16	16.8	17.6	18.4	19.1	19.9	20.7	21.5	22.2	23	23.8	24.6	25.3	26.1	26.9	27.7	28.4	29.2	30	30.8	31.6	32.4	33.2	34	34.8	35.6	36.4	37.2	38	38.8

RU Motor in the upper right

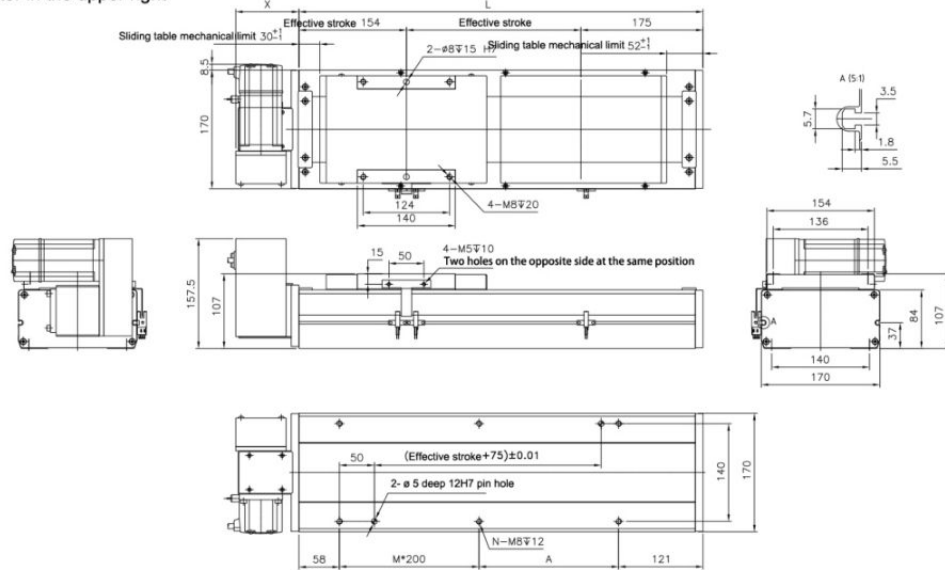

Effective stroke	100	150	200	250	300	350	400	450	500	550	600	650	700	750	800	850	900	950	1000	1050	1100	1150	1200	1250	1300	1350	1400	1450	1500	1550
L	429	479	529	579	629	679	729	779	829	879	929	979	1029	1079	1129	1179	1229	1279	1329	1379	1429	1479	1529	1579	1629	1679	1729	1779	1829	1879
A	50	100	150	200	50	100	150	200	50	100	150	200	50	100	150	200	50	100	150	200	50	100	150	200	50	100	150	200	50	100
M	1	1	1	1	2	2	2	2	3	3	3	3	4	4	4	4	5	5	5	5	6	6	6	6	7	7	7	7	8	8
N	6	6	6	6	8	8	8	8	10	10	10	10	12	12	12	12	14	14	14	14	16	16	16	16	18	18	18	18	20	20
KG	16	16.8	17.6	18.4	19.1	19.9	20.7	21.5	22.2	23	23.8	24.6	25.3	26.1	26.9	27.7	28.4	29.2	30	30.8	31.6	32.4	33.2	34	34.8	35.6	36.4	37.2	38	38.8

*L: The total length will vary according to the motor model, and the actual length will be based on 3D.

L The motor on the left side

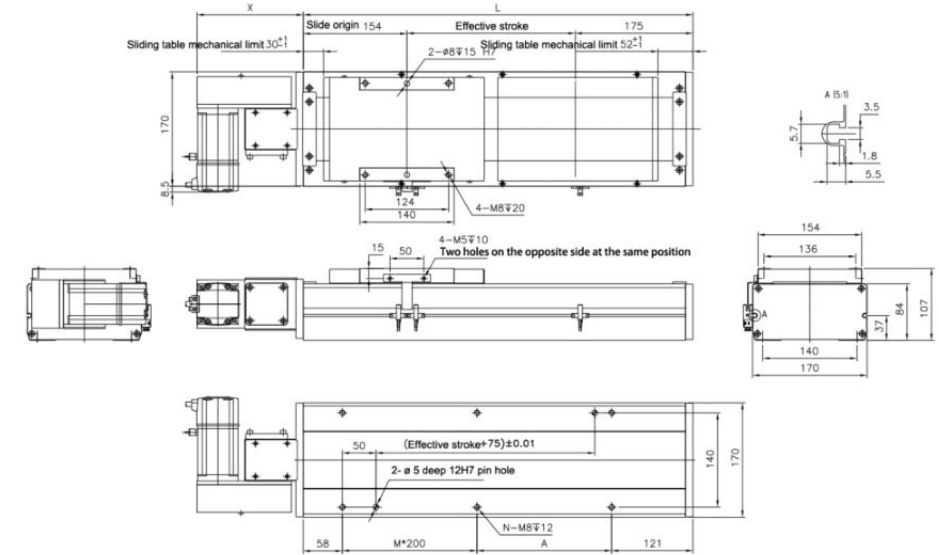

Effective stroke	100	150	200	250	300	350	400	450	500	550	600	650	700	750	800	850	900	950	1000	1050	1100	1150	1200	1250	1300	1350	1400	1450	1500	1550
L	429	479	529	579	629	679	729	779	829	879	929	979	1029	1079	1129	1179	1229	1279	1329	1379	1429	1479	1529	1579	1629	1679	1729	1779	1829	1879
A	50	100	150	200	50	100	150	200	50	100	150	200	50	100	150	200	50	100	150	200	50	100	150	200	50	100	150	200	50	100
M	1	1	1	1	2	2	2	2	3	3	3	3	4	4	4	4	5	5	5	5	6	6	6	6	7	7	7	7	8	8
N	6	6	6	6	8	8	8	8	10	10	10	10	12	12	12	12	14	14	14	14	16	16	16	16	18	18	18	18	20	20
KG	16	16.8	17.6	18.4	19.1	19.9	20.7	21.5	22.2	23	23.8	24.6	25.3	26.1	26.9	27.7	28.4	29.2	30	30.8	31.6	32.4	33.2	34	34.8	35.6	36.4	37.2	38	38.8

R The motor on the right side

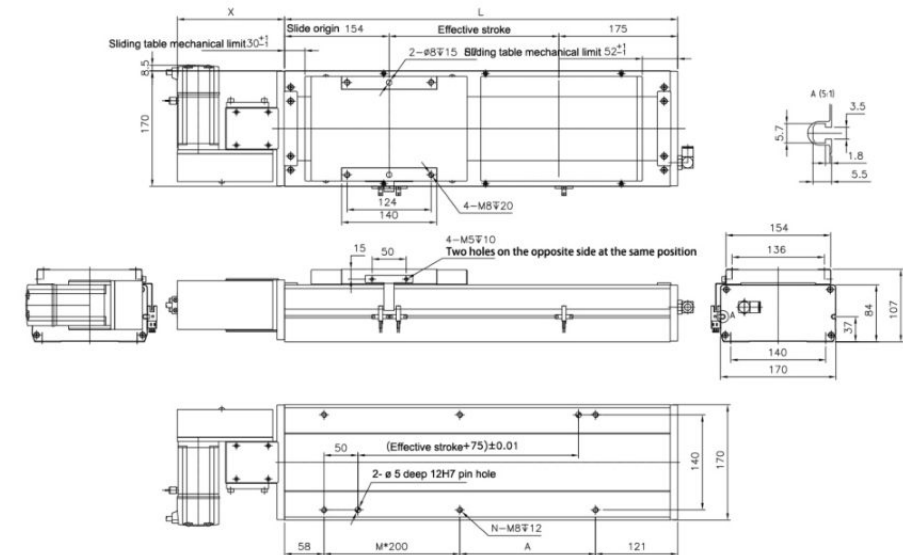

Effective stroke	100	150	200	250	300	350	400	450	500	550	600	650	700	750	800	850	900	950	1000	1050	1100	1150	1200	1250	1300	1350	1400	1450	1500	1550
L	429	479	529	579	629	679	729	779	829	879	929	979	1029	1079	1129	1179	1229	1279	1329	1379	1429	1479	1529	1579	1629	1679	1729	1779	1829	1879
A	50	100	150	200	50	100	150	200	50	100	150	200	50	100	150	200	50	100	150	200	50	100	150	200	50	100	150	200	50	100
M	1	1	1	1	2	2	2	2	3	3	3	3	4	4	4	4	5	5	5	5	6	6	6	6	7	7	7	7	8	8
N	6	6	6	6	8	8	8	8	10	10	10	10	12	12	12	12	14	14	14	14	16	16	16	16	18	18	18	18	20	20
KG	16	16.8	17.6	18.4	19.1	19.9	20.7	21.5	22.2	23	23.8	24.6	25.3	26.1	26.9	27.7	28.4	29.2	30	30.8	31.6	32.4	33.2	34	34.8	35.6	36.4	37.2	38	38.8

*L: The total length will vary according to the motor model, and the actual length will be based on 3D.

LD Motor in the lower left side

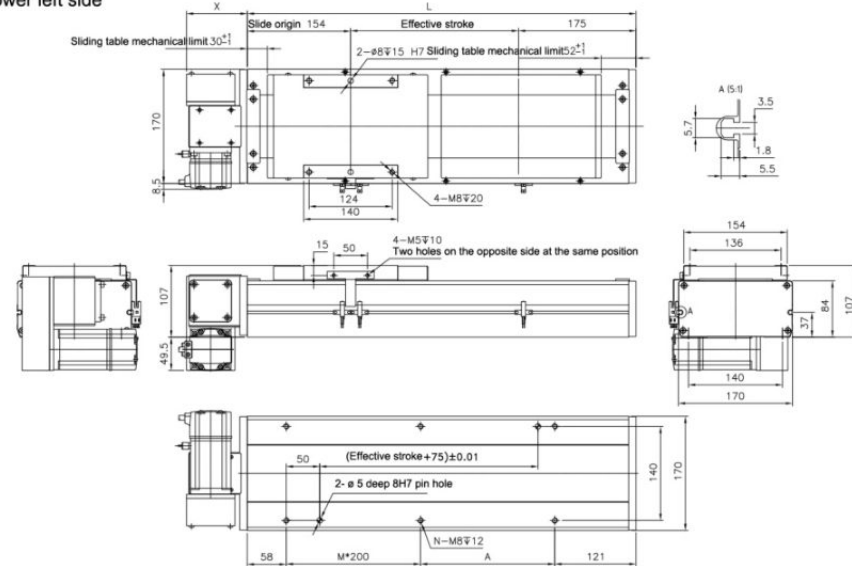

Effective stroke	100	150	200	250	300	350	400	450	500	550	600	650	700	750	800	850	900	950	1000	1050	1100	1150	1200	1250	1300	1350	1400	1450	1500	1550
L	429	479	529	579	629	679	729	779	829	879	929	979	1029	1079	1129	1179	1229	1279	1329	1379	1429	1479	1529	1579	1629	1679	1729	1779	1829	1879
A	50	100	150	200	50	100	150	200	50	100	150	200	50	100	150	200	50	100	150	200	50	100	150	200	50	100	150	200	50	100
M	1	1	1	1	2	2	2	2	3	3	3	3	3	4	4	4	4	5	5	5	5	6	6	6	6	7	7	7	8	8
N	6	6	6	6	8	8	8	8	10	10	10	10	12	12	12	12	14	14	14	14	16	16	16	16	18	18	18	18	20	20
KG	16	16.8	17.6	18.4	19.1	19.9	20.7	21.5	22.2	23	23.8	24.6	25.3	26.1	26.9	27.7	28.4	29.2	30	30.8	31.6	32.4	33.2	34	34.8	35.6	36.4	37.2	38	38.8

RD In the lower right side

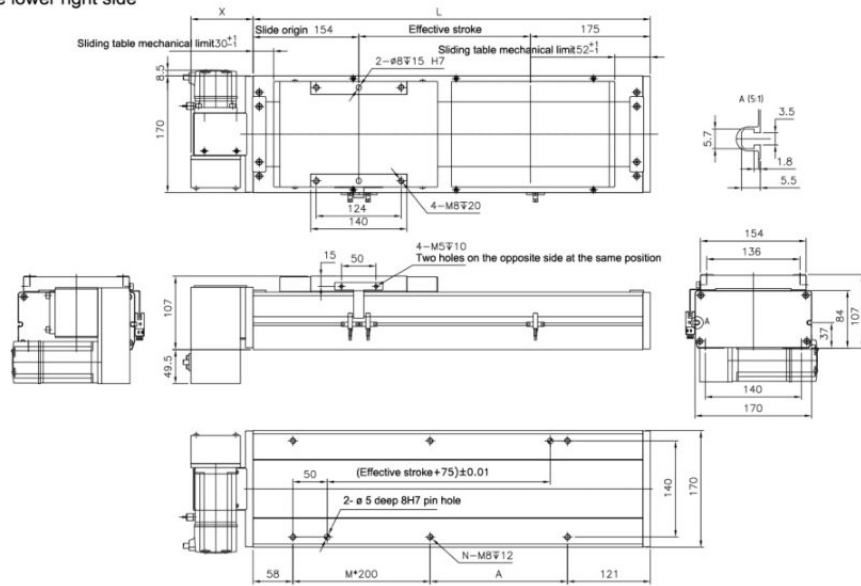

Effective stroke	100	150	200	250	300	350	400	450	500	550	600	650	700	750	800	850	900	950	1000	1050	1100	1150	1200	1250	1300	1350	1400	1450	1500	1550
L	429	479	529	579	629	679	729	779	829	879	929	979	1029	1079	1129	1179	1229	1279	1329	1379	1429	1479	1529	1579	1629	1679	1729	1779	1829	1879
A	50	100	150	200	50	100	150	200	50	100	150	200	50	100	150	200	50	100	150	200	50	100	150	200	50	100	150	200	50	100
M	1	1	1	1	2	2	2	2	3	3	3	3	4	4	4	4	5	5	5	5	6	6	6	6	7	7	7	8	8	
N	6	6	6	6	8	8	8	8	10	10	10	10	12	12	12	12	14	14	14	14	16	16	16	16	18	18	18	18	20	20
KG	16	16.8	17.6	18.4	19.1	19.9	20.7	21.5	22.2	23	23.8	24.6	25.3	26.1	26.9	27.7	28.4	29.2	30	30.8	31.6	32.4	33.2	34	34.8	35.6	36.4	37.2	38	38.8

*L: The total length will vary according to the motor model, and the actual length will be based on 3D.

Sliding table series

YTC&ENB series

Gear and rack & European standard belt

CONTENTS

YTC 17



Body width: 170mm
Stroke: 5000mm
maximum load: 160kg P145

YTC 22



Body width: 220mm
Stroke: 5000mm
maximum load: 200kg P147

ENB 65



Body width: 65mm
Stroke: 5500mm
maximum load: 25kg P149

ENB 80



Body width: 80mm
Stroke: 5500mm
maximum load: 60kg P153