

2023



THE EVOLUTION OF STRENGTH TRAINING EQUIPMENT.

## RACKS & SINGLE STACKS

MADE IN THE U.S.A. 



# PRODIGY



## The most versatile Racks in the world.

The Prodigy line of racks from PRIME was created to blur the line between commercial and home-gym equipment. The line features four rack options, all of which can be combined and connected in a plethora of configuration options, taking customization to another level.

- + Available in four Rack variations
- + Plethora of add-on and attachment options
- + 3"x3" 11-gauge steel construct
- + Nearly infinite configuration possibilities
- + Proudly manufactured in the USA



# PRODIGY

## Where convenience & functionality collide.

The centerpiece of the PRIME Prodigy Rack line is the Prodigy HLP (High/Low Pulley) Selectorized Rack. Packing an incredible amount of versatility and functionality, the Prodigy HLP Selectorized Rack combines the benefits of a functional trainer with the convenience and dependability of a squat rack. Featuring both fixed and adjustable dual pulley systems, and 350 lb. weight stacks per side, the HLP Selectorized Rack is built to accommodate a variety of training types, while simultaneously challenging even the strongest of lifters.

- + Dual 350lbs weight stacks with built in band pegs
- + Features two high/low adjustable pulleys and two stationary high pulleys
- + Nearly limitless exercise options in a compact footprint
- + Available in 2:1 or 4:1 ratio option



**Prodigy HLP Selectorized Rack**  
Add-on accessories sold separately

### Dimensions:

62L x 57W x 92H in.  
157L x 145W x 234H cm.

### Weight:

1,240lbs. / 563kgs.

**These PRIME Accessories make excellent additions to the Prodigy HLP Racks:**

- + RO-T8 Handles
- + RO-T8 3N1 & 4N1 Handles
- + RO-T8 Short & Long Bars
- + RO-T8 Landmine
- + RO-T8 Spreader Bar
- + Quick Connect Collars
- + KAZ Handles
- + Squat Wedges (Original and SOLOS)



# PRODIGY

## Strength meets athletic performance training.

Similar to its HLP Selectorized counterpart, the Prodigy HLP Plate Loaded Rack features two dual pulley systems for an extraordinary amount of functionality and exercise possibilities. What makes the HLP Plate Loaded Rack unique is PRIME's cable ratio technology. The simple adjustment of a pin allows the user to change the cable ratio from 2:1 to 4:1. So, whether you're looking to accomplish serious strength work, or intricate speed-oriented exercises, this technology is a must-have!

- + Easily adjustable from 2:1 to 4:1 cable ratio
- + Features two high/low adjustable pulleys and two stationary high pulleys
- + Cost effective and user-friendly plate-loaded system
- + Nearly infinite exercise possibilities in one rack



### Dimensions:

62L x 75W x 92H in.  
157L x 190W x 234H cm.

### Weight:

530lbs. / 240kgs.

**Prodigy HLP Plate Loaded Rack**  
Add-on accessories sold separately

**These PRIME Accessories make excellent additions to the Prodigy HLP Racks:**

- + RO-T8 Handles
- + RO-T8 3N1 & 4N1 Handles
- + RO-T8 Short & Long Bars
- + RO-T8 Landmine
- + RO-T8 Spreader Bar
- + Quick Connect Collars
- + KAZ Handles
- + Squat Wedges (Original and SOLOS)



# PRODIGY

## Prodigy Power Rack

The PRIME Prodigy Power Rack features a robust 3"x3" tube construct of 11-gauge steel with uprights that have 1" holes with 2" spacing for a wide variety of adjustment options. Each Prodigy Rack is finished with a zinc primer powder and top coated for superior durability and longevity. The Prodigy Power Rack is also the perfect addition to our HLP Racks and can easily be configured in a variety of fashions.

**Dimensions:**

61L x 51W x 89H in.  
155L x 130W x 226H cm.

**Weight:**

465lbs. / 211kgs.



---

## Prodigy Half Rack

Like the rest of the Prodigy line, the Prodigy Half Rack also features world-class manufacturing craftsmanship with the highest quality materials on the market.

The Prodigy Half Rack is also the perfect addition to our HLP Racks and easily be configured in a variety of fashions.

**Dimensions:**

49L x 54W x 89H in.  
124L x 137W x 226H cm.

**Weight:**

320lbs. / 145kgs.





# PRODIGY

## Prodigy Rack Connection System



### Prodigy – Center Connection System includes:

- 89" Round Crossmember Bar (x1)
- 43" Square Crossmember Bars (x4)
- 89" Upright Square Bar (x2)
- 8" Square Crossmember Bars (x2)
- All necessary hardware

The Prodigy Center Connection System offers a functional, clean and convenient option to connect any of our four Prodigy Rack options. The steel tubing construct also provides increased rigidity and a solid feel – especially appreciated with exercising scenarios involving multiple rack users. The Center Connection System also allows you to not only utilize and store popular Prodigy Rack Attachments with ease, such as the Dip Bar and Step Up Platform, but also creates a functional space for the use of battle ropes, TRX Bands, etc.

## Prodigy Height Extension Kit

### AVAILABLE for both the HLP Racks and HLP Single Stacks

This attachment allows you to increase height on your HLP Racks and/or HLP Single Stacks.

#### Adjustments include:

##### **Pull-up height (Racks ONLY):**

100.25", 102.5", 107.5"

##### **Fixed pulleys:**

From 90.25" to 95.25" or 100.25"

These adjustments will increase the overall height of your HLP Rack and/or HLP Single Stack from 90.25" to 108.25".

#### This product is only compatible with:

- PRODIGY HLP Selectorized Rack
- PRODIGY HLP Plate Loaded Rack
- PRODIGY HLP Selectorized Single Stack
- PRODIGY HLP Plate Loaded Single Stack





# PRODIGY

## Compact Footprint. Huge Possibilities.

The Prodigy HLP Single Stack series was born out of necessity for those looking for a compact, cost effective, versatile solution for a legitimate cable station. The search is over – introducing the Prodigy HLP Selectorized and Plate Loaded Single Stacks. Both of these options offer an incredible amount of versatility and functionality, featuring both a fixed upper pulley and fully adjustable pulley system. These products also come equipped with built-in band pegs for ease of use when adding bands to applicable exercise, convenient storage capabilities, and accommodate a wide variety of the increasingly popular Prodigy attachment options, like the Lat Pulldown Seat, Low Row Footplate, Dip Bar, and Single Leg Roller Pad, to name a few.

### Prodigy HLP Selectorized Single Stack:

- + 350lbs weight stacks with built in band pegs
- + Features a high/low adjustable pulley and a stationary high pulley
- + Offers a wide variety of attachment options with convenient storage capabilities—all in a very compact footprint
- + Available in 2:1 or 4:1 ratio option

### Dimensions:

62L x 63W x 92H in.  
157L x 160W x 234H cm.

### Weight:

628lbs. / 285kgs.

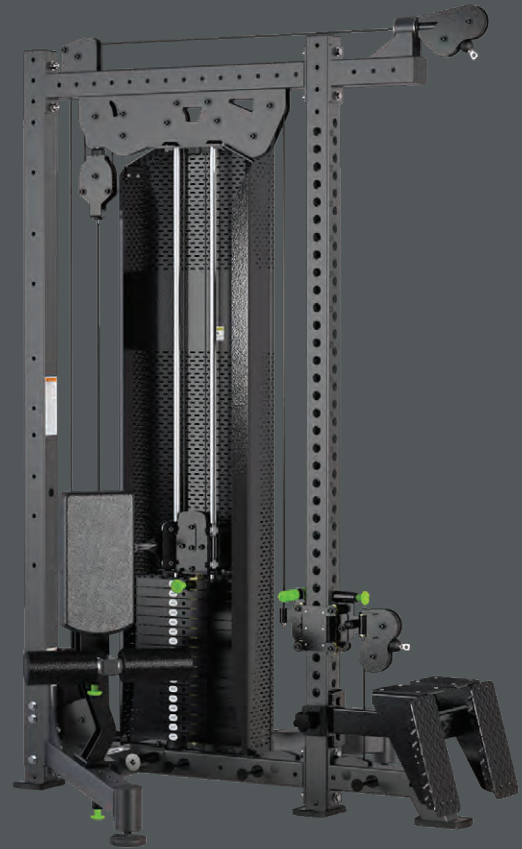

### Prodigy HLP Selectorized Single Stack

Add-on accessories sold separately

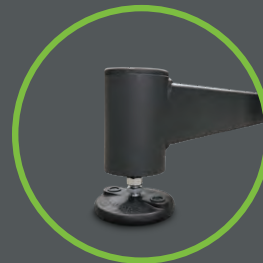

The Prodigy HLP Single Stacks each feature two easy-to-use rotational leveling pads, which help ensure stability based on a variety of gym floor surface types.



# PRODIGY

## Major Versatility. Minimal Expense.

The Prodigy HLP Single Stack series was born out of necessity for those looking for a compact, cost effective, versatile solution for a legitimate cable station. The search is over – introducing the Prodigy HLP Selectorized and Plate Loaded Single Stacks. Both of these options offer an incredible amount of versatility and functionality, featuring both a fixed upper pulley and fully adjustable pulley system. These products also come equipped with built-in band pegs for ease of use when adding bands to applicable exercise, convenient storage capabilities, and accommodate a wide variety of the increasingly popular Prodigy attachment options, like the Lat Pulldown Seat, Low Row Footplate, Dip Bar, and Single Leg Roller Pad, to name a few.

### Prodigy HLP Plate Loaded Single Stack:

- + Features the cable ratio technology allowing for the easy adjustment from a 2:1 to a 4:1 ratio. So, whether you're looking to accomplish serious strength work or intricate speed-oriented exercises, this technology is a must-have!
- + Features a high/low adjustable pulley and a stationary high pulley
- + Offers a wide variety of attachment options with convenient storage capabilities—all in a very compact footprint
- + Cost effective

### Dimensions:

62L x 63W x 92H in.  
157L x 160W x 234H cm.

### Weight:

300lbs. / 136kgs.



**Prodigy HLP Plate Loaded Single Stack**  
Add-on accessories sold separately

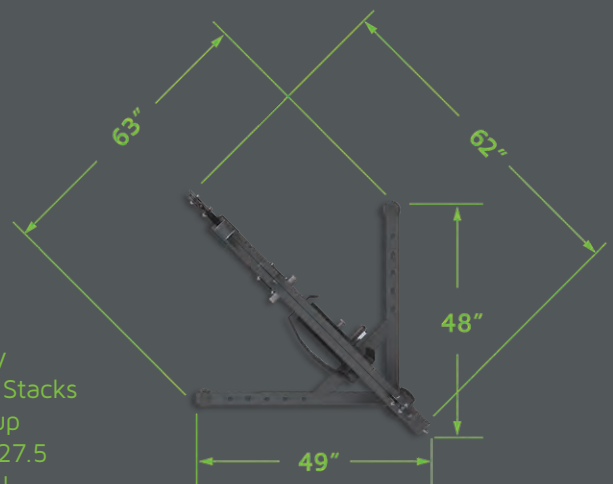

The Prodigy HLP Single Stacks each take up as little as 27.5 square feet!

**27.5 Square Feet**





# PRODIGY

## All the additions you could want.

A key element of what makes the PRIME Prodigy line so versatile is the wide assortment of add-on features for the line. With limited exceptions, each rack within the Prodigy line can be configured and customized to achieve a nearly limitless number of exercise options. The add-on features range from tried and true rack staples, such as a dip attachment, step-up platform, landmine attachment, and a variety of band peg locations, to innovative options like our lock-in bench centering technology, RO-T8 pull-up station, an attachable pulldown seat and seated row footplate. Take a minute to check out each rack option and let your imagination run wild as you create the perfect rack for your gym.



Dip Bar



Step Up Platform



Speed Bag Mount  
(Actual Speed Bag not included)



Landmine



Olympic Bar Holder



Spotter Arms (1 Pair)



Ball Target w/Heavy Bag Hanger



Adjustable Band Pegs (6 Pack)



Back Storage Bar



Low Row Foot Plate



Adjustable RO-T8  
Pull-up Station



Spotter Bars (1 Pair)



J-Hooks (1 Pair)



Flying Pull-Up Station



Weight Peg Storage  
Kit (10 pack)



Pulldown Seat



Dumbbell Cradles  
(1 Pair)



Single Leg Roller Pad



Bench Centering Device



Storage Tray



Rack Height  
Extension Kit



## Serious racks built for serious results.

The PRIME Steel Line of racks are in a class of their own, designed for the serious training facility in mind. PRIME Steel Racks feature:

- + Sturdy tubular steel design.
- + Available in an extremely robust 4x4" option.
- + Lock-in weight bench centering device.
- + Upper permanent and lower retractable band rods.
- + Dedicated spotter entry and platform area.
- + Ample weight plate and bumper plate storage.
- + Vertical barbell holders and built-in hooks for accessory storage.
- + Popper Pin safety feature on J-Hooks-ensuring J-Hooks remain locked in place during use.
- + Multi-grip pull up station.
- + Reinforced spotter bars.



PRIME Steel Double Half Rack

The **PRIME Racks** line includes:

- + Commercial 4" PRIME Steel Double Half Rack
- + Commercial 4" PRIME Steel Half Rack

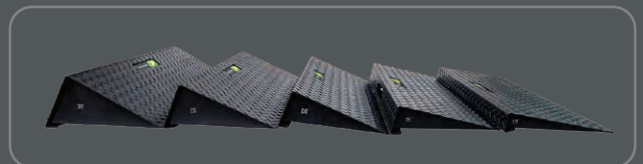

PRIME Squat Wedges. Available in 5, 10, 15, 20, 25 and 30 degrees.

Prime Steel Double Half Rack



Dimensions:  
120L x 89W x 100H in.  
305L x 226W x 254H cm.  
Weight: 1,858lbs. / 843kgs.

**Prime Steel Half Rack & Accessories**



**Dimensions:**  
 73L x 89W x 100H in.  
 185L x 226W x 254W cm.

**Weight:**  
 1,324lbs. / 601kgs.



Pull Up Station



Upper Band Rod Bar



Storage Hooks

Bumper  
Plate  
Storage

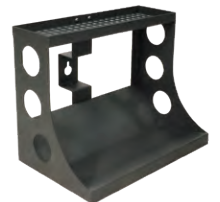

Lower Retractable Band Rods



Spotter Platform/  
Barbell Storage



Bench  
Centering  
Device



For more information on our latest innovations, visit [PrimeFitnessUSA.com](https://PrimeFitnessUSA.com)

©2023 Specialty Fitness Systems, LLC. Machine images represent products at the time of printing.  
Future specifications are subject to change. PRIME, Evolution, Hybrid, and SmartCam are trademarks of Specialty Fitness Systems.  
Any use of these trademarks, without express written consent of Specialty Fitness Systems, is forbidden.

MADE IN THE U.S.A. 