



Dumbbell Rack Assembly Instructions

Delivery Inspection

Upon arrival, it is **very important** that you **inspect each piece of equipment** thoroughly for any damages. The carrier is solely responsible for the safe delivery of the equipment. If any damages are discovered during delivery, show it to the driver and request that the driver documents all the damages on the bill of lading. Be sure to keep a copy of the bill of lading for your records. Should the driver not be able to correct the problem, contact Prime Fitness Customer Service Department at 1-855-269-4378 and provide them with the proper information. Damages that are not evident or discovered during delivery must be brought to the attention of the carrier within 5 days of delivery. Any delays in contacting the carrier could invalidate your rights to a claim.

Safety Information

It is the sole responsibility of the facility owner/owners of the equipment to read the owner's/user's manual and instruct users on the proper orientation of the equipment and to warn them of the potential hazards. All users should read the warning labels and instructional placards prior to using the equipment.

Machine Specifications/Torque Specification

Machine Weight	470 lbs	213 kg	Bolt Size	Torque Setting
Dimensions	97"L x 32"W x 46"H	246 cm L x 81 cm W x 117 cm H		

The dimensions stated in the machine specifications are the recommended minimum dimensions as set forth by the manufacturer. The actual area for access and passage shall be the responsibility of the facility and should take into account this training envelope and any required local codes or regulations. The surface should be stable, properly leveled and does not deviate more than 1/8" over a distance of 10'. The manufacturer is not responsible for the actual anchoring of the equipment - consult a professional contractor. Use fasteners having a minimum of 500lbs tensile capacity (3/8" grade 2 bolts or better).

Tools Required

- 5/16 ALLEN WRENCH - 7/32 ALLEN WRENCH - 9/16 WRENCH OR SOCKET - 7/16 WRENCH OR SOCKET - PHILLIPS HEAD SCREWDRIVER

Parts Inventory

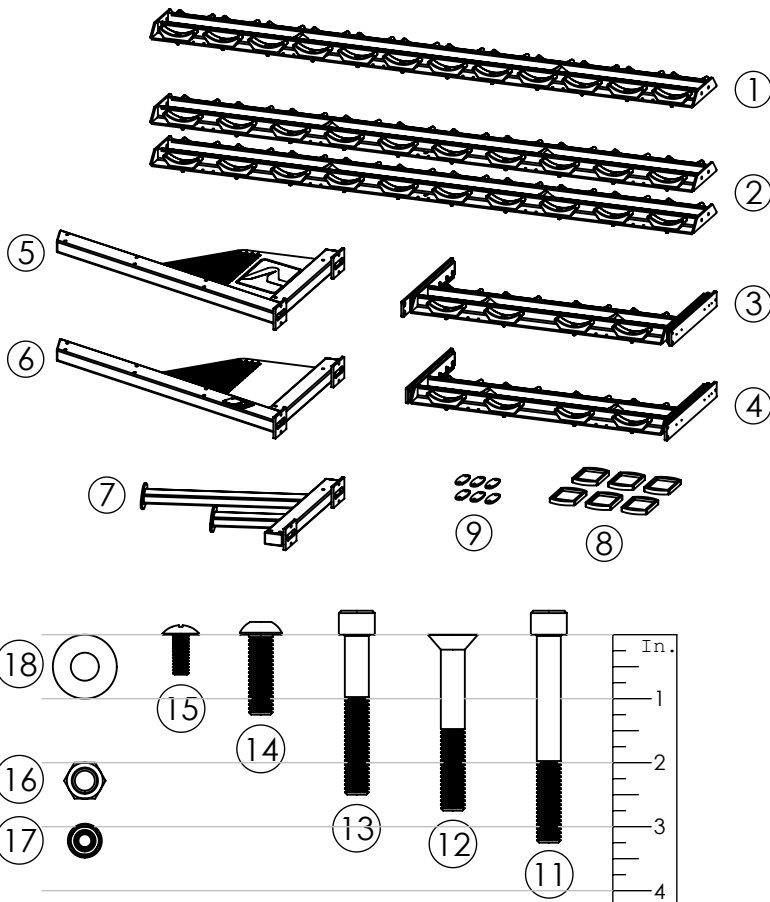

Standard Unit

#	Description	Qty
1	Top Shelf	1
2	Middle Shelf	2
3	Right Drawer	1
4	Left Drawer	1
5	Right Support	1
6	Left Support	1
7	Middle Support	1
8	Rubber Footpad	6
9	Shelf Spacer	6
10	Weight Numbers (Set)	1
11	SHCS 3/8" x 3.25	12
12	FHS 3/8" x 2.75	3
13	SHCS 3/8" x 2.50	6
14	BHSCS 3/8" x 1.25	4
15	Screw 1/4" x 0.63	40
16	Nyloc Nut 3/8"	16
17	Flange Nut 1/4"	40
18	Washer 3/8"	34

10 - Set contains 20+ numbered plates.
- Numbers on plates depends on set purchased.

Dumbbell Rack Assembly Instructions

Assembly Instructions

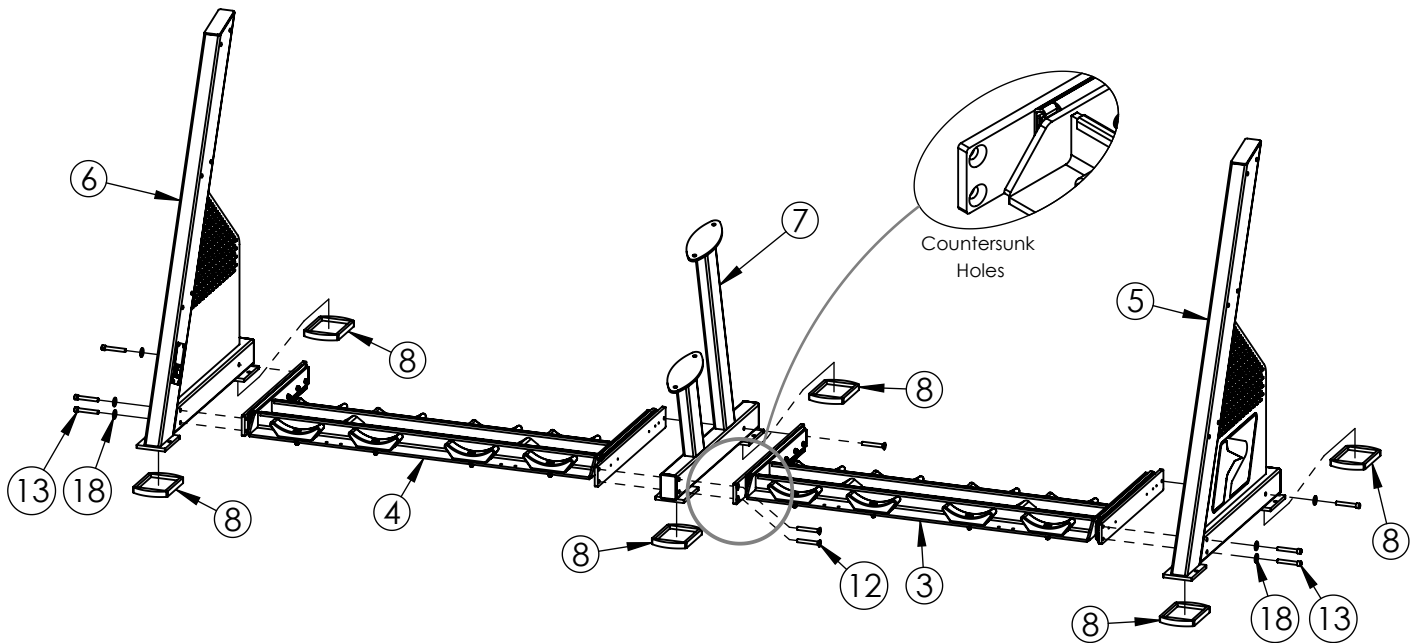

Step 1: Fit Rubber Footpads (7) onto the support frames as shown. Assemble the Right Drawer (3), Left Drawer (4), Right Support (5), Left Support (6), and Middle Support (7) together as shown, using the appropriate fasteners. *Do not tighten any bolts until mentioned in Step 5.*

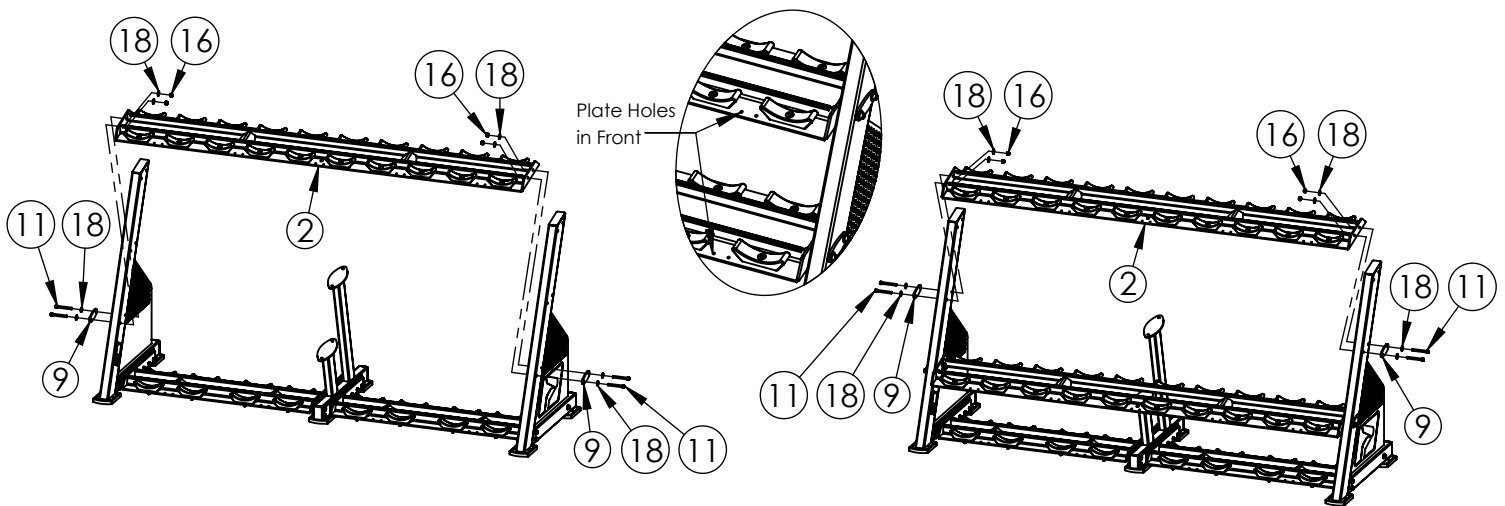

Step 2: Bolt one Middle Shelf (2) through the lower set of holes in the Right and Left Supports. Orient the Middle Shelf such that the holes for the numbered plates are in the front.

Step 3: Bolt the other Middle Shelf (2) through the next set of holes in the Right and Left Supports. Orient the Middle Shelf such that the holes for the numbered plates are in the front.

Assembly Instructions

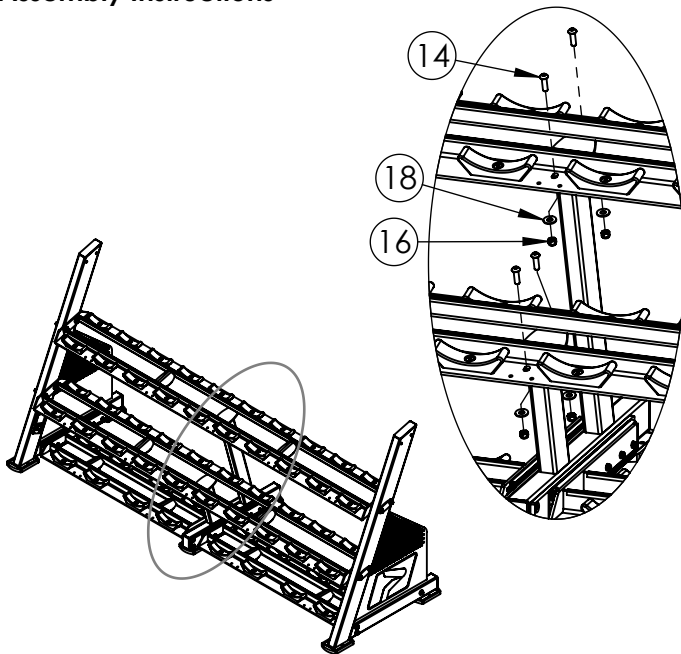

Step 4: Bolt the two Middle Shelves to the Middle Support.

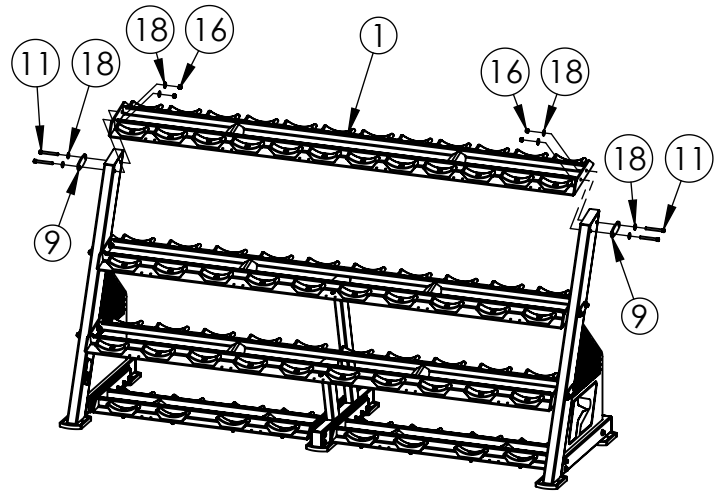

Step 5: Bolt the Top Shelf (1) through the upper set of holes in the Right and Left Supports.

Tighten all bolts to the torque specified on page 1.

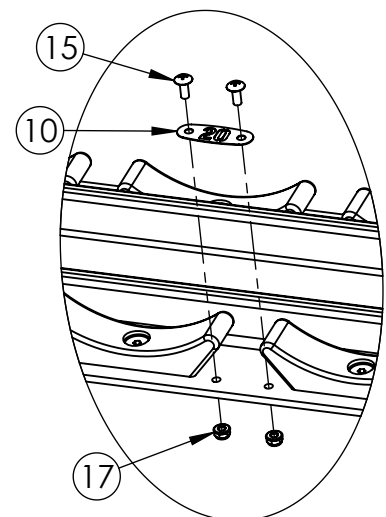
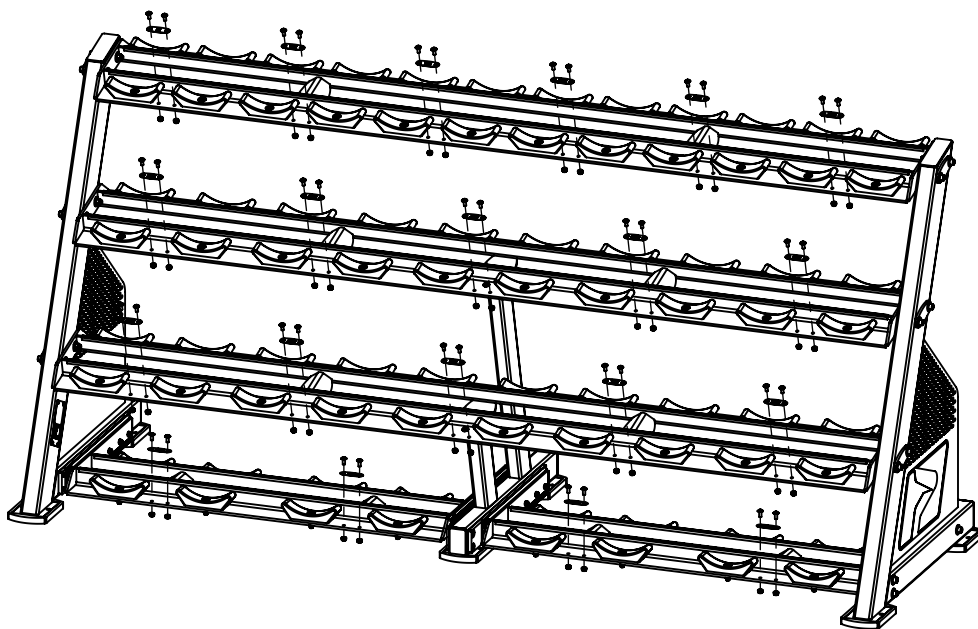

Step 6: Attach the numbered weight plates (10) to the shelves and drawers using 1/4" Screws (15) and Flange Nuts (17).

The plates can be attached between any pair of cradles, and the locations are the choice of the owner.



Dumbbell Rack Assembly Instructions

Inspecting the Dumbbell Rack

Verify Complete and Safe Assembly

1. All bolts are tight (20 ft.lbs. recommended for 3/8" bolts).
2. Dumbbell rack is level and all footpads touch the floor.
3. Drawer shelves slide through full travel.

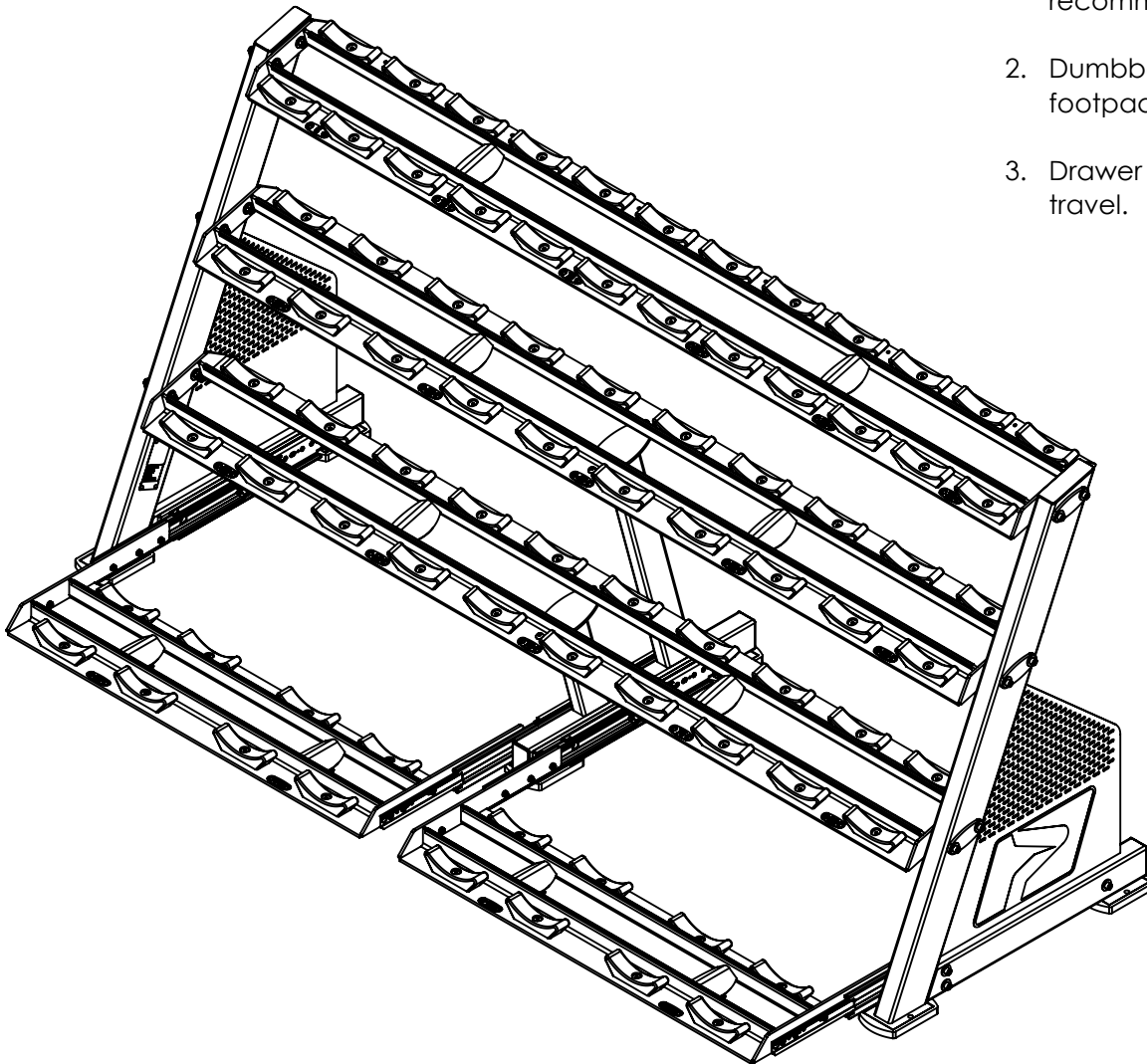

Warranty Information

Limited Warranty

Prime Fitness USA Products warrants its products to the original purchaser to be free from defect in material and workmanship under normal use or service. All warranty periods begin from the date of delivery to the original purchaser.

Commercial Strength Products

- Ten Year Warranty-Structural Frame breaks and Weight Stack Plates*
- Five Year Warranty-Structural moving parts, Smartcam, Pulleys, and Pivot Bearings
- One Year Warranty-Linear Bearings, Grips, Belts, and Cables
- 90 Day Warranty-Upholstery, Gas Shocks, Popper Pins, and Accessories

This written warranty in lieu of all other warranties expressed or implied, including the warranties of merchantability and fitness for use of all other obligations or liabilities on our part, and we neither assume, nor authorize another person to assume for us, any liability in connection with the sale of this Prime Fitness USA's equipment. This warranty shall not apply to this Prime Fitness USA's equipment or to any part thereof, which has been subject to accident, negligence, alteration without written consent from Prime Fitness USA, improper assembly or installation, abuse, misuse, reconditioning or refurbishing by third party, or to a lack of maintenance in accordance with our recommended maintenance program. We make no warranty whatsoever in respect to accessories or parts not manufactured by us. The term original purchaser as used in the warranty, shall be deemed to mean that the person or entity for which this Prime Fitness USA equipment is originally installed. Prime Fitness USA shall not be liable for any loss or damage, including incidental or consequential damages, directly or indirectly, from the use or loss of our equipment. Without limiting the generality of the foregoing, this exclusion from liability embraces the purchaser's expenses for downtime, damages for which the purchaser may be liable to other persons and damage to property. We neither assume, nor authorize any person to assume for us, any other liability in connection with the sale or use of our equipment. There are no oral agreements or warranties collateral to or affecting this agreement.

*Applies only for those parts that our own examination disclosed, to our satisfaction, to be defective. "Structural Frame" refers to the main supporting frame section on each unit.