

## TUSCAN LARGE FAMILY – PRE-CAST MODULAR KIT

Our beautiful traditional ITALIAN MADE (since 1959). The Tuscan is our most popular large family sized wood-fired oven. This beautiful large “Italian Made” wood fired pizza oven is ideal for families and entertaining. Capable of cooking 3 pizzas at once. More than pizzas – enjoy the flavours of wood-fired roasts, meats, golden vegetables, delicious stews and even desserts. Achieve high cooking temperatures 400+ degrees Celsius and excellent heat retention for slow cooking and baking. External dome wall remains cool to touch – safe for the kids long lasting heat retention for slow cooking & baking. Pizzas cook in only 2-3 minutes!

### Tuscan DIY Pizza Oven Kit includes:

- Quality pre-cast refractory concrete oven dome sections
- Pre-cast front arch (terracotta red or sandstone colours) can be painted another colour
- Pre-cast solid refractory cooking floor slab (not firebricks)
- Flue & Cowl Cap: Stainless Steel 7 inch flue (can be painted black easily with Stove bright Black Fireplace Heatproof spray paint.)
- Lift off stainless steel door
- Ceramic insulating blanket, chicken wire & vermiculite
- Step-by-step photo instructions, video demonstration & support
- Dome: Client to provide concrete mix to render dome (dome can be painted with masonry paint)
- Can I paint the Oven Arch? Yes you can paint the arch with heatproof masonry paint.
- Does it fit in a box trailer? Yes as long as your trailer can fit 120cm W x 120cm L x 100cmH pallet crate (350-450KG)
- How do I unload the oven at home? No machinery is needed as the kit is in pieces (approx. 60-70kg per piece)
- We home deliver Australia-wide or pick up available from Metro Depots.
- Warranty: 12 months



# PIZZA OVENS R-US

## Dimensions:

- External base: 120cm D x 110cm W
- Internal Front to back: 100cm D x 70cm W
- Kit weight: 360Kg
- Flue: 180mm diameter (1 m high)
- Door opening: 43cm W x 25cm H
- Arch: 86cm W x 48cm H
- Dome: 47cm Int H

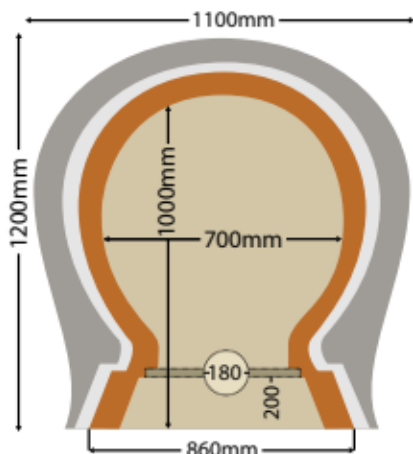

### Tuscan 6B

Mouth Door Opening: 430 W x 250 H  
 External Base: 1100 W x 1200 D  
 Weight: 300Kg  
 Flue: 180mm Diameter  
 Arch: 860 W x 480 H  
 Internal Dome: 470 Int H (-80mm floor)  
 Internal Front to Back: 1000 D x 700 W  
 External Dome: 600mm H  
 Capacity: 3 - 4 pizzas

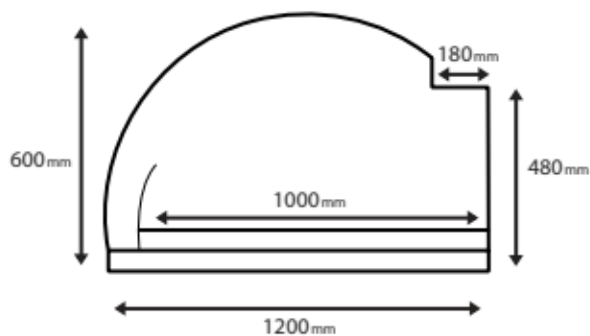
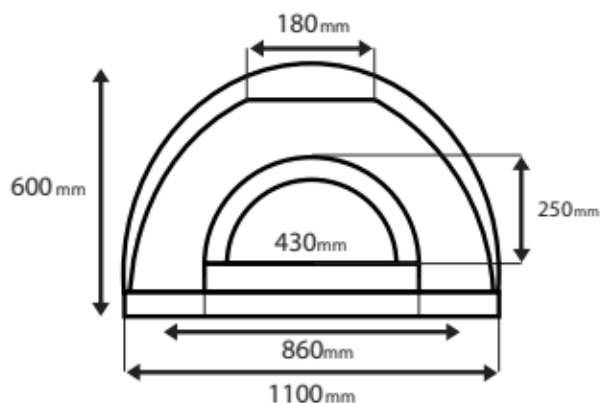

[www.pizzaovensrus.com.au](http://www.pizzaovensrus.com.au) | [info@pizzaovensrus.com.au](mailto:info@pizzaovensrus.com.au) | 0402 551 467 | 1300 032 822



Australian Owned  
Business



Shipping  
Australia Wide



Expert Advice



Best Price  
Guaranteed

# PIZZA OVENS R-US



## Tuscan FAMILY SIZE PIZZA OVEN



### DIY PIZZA OVEN KIT (OR FULLY INSTALLED)

Made on the "Adriatic Coast" of Italy. The Tuscan is our most popular pizza oven for families. Ideal for entertaining, pizza parties or any other function your family would like to host. This beautiful "Italian Made" wood fired pizza oven is capable of cooking 4 pizzas at once.

### Cook Anything

More than pizzas - enjoy the flavours of wood-fired roasts, meats, golden vegetables, delicious stews and even desserts.

### Cooking Information

Heat your oven in 40-60 minutes

Achieve high cooking temperatures 400+ Celsius degrees

External dome wall remains cool to touch - safe for kids

Long lasting heat retention for slow cooking and baking

Cooking Time for Pizzas: 2 -3 Minutes

### Specifications

Internal front to back: 1000 D x 700 W

External base requirement: 1100 W x 1200 D

Weight: 360 kg

Door Opening: 430W x 250 H

Front Arch: 860 W x 480 H

Flue: 180 mm

Door: 43cm wide (available in stainless steel)



### Front Arch Options (can be painted any colour)



We are an Australian owned and operated business with several warehouse centres across Australia offering metro depot pick up or home delivery. With access to a wide range of manufacturers, we help you choose the best quality wood-fired oven for your family.

We deliver anywhere in Australia.

[www.pizzaovensrus.com.au](http://www.pizzaovensrus.com.au) | [info@pizzaovensrus.com.au](mailto:info@pizzaovensrus.com.au) | 0402 551 467 | 1300 032 822



Australian Owned  
Business



Shipping  
Australia Wide



Expert Advice



Best Price  
Guaranteed

# PIZZA OVENS R-US



## DIY Pizza Oven Kits



We offer our clients the highest quality authentic "Italian Made" wood fired pizza oven kits with over three generations of ITALIAN craftsmanship.

### Complete DIY Pizza Oven Installation Kit Includes

Each pizza oven section is made in Italy from the highest quality refractory granite materials that will perform, give the best cooking results and last a lifetime (unlike inferior cheaper ovens that deteriorate quickly, have heating and cooking performance issues)

- Precast Front Arch
- Pre-cast oven dome sections
- Refractory cooking floor
- Flue kit, stainless steel flue pipe and cap
- Optional stainless steel or traditional black door
- Ceramic insulating blanket
- Chicken wire & vermiculite
- (all you need to supply is sand & cement mixes for the external dome)

### Support

- Step-by-step photo instructions
- Video demonstration via YouTube
- 7 days a week phone support
- We provide expert advice with over 20 years experience



[www.pizzaovensrus.com.au](http://www.pizzaovensrus.com.au) | [info@pizzaovensrus.com.au](mailto:info@pizzaovensrus.com.au) | 0402 551 467 | 1300 032 822



Australian Owned  
Business



Shipping  
Australia Wide



Expert Advice



Best Price  
Guaranteed

## SUPPORT BASE CONSTRUCTION

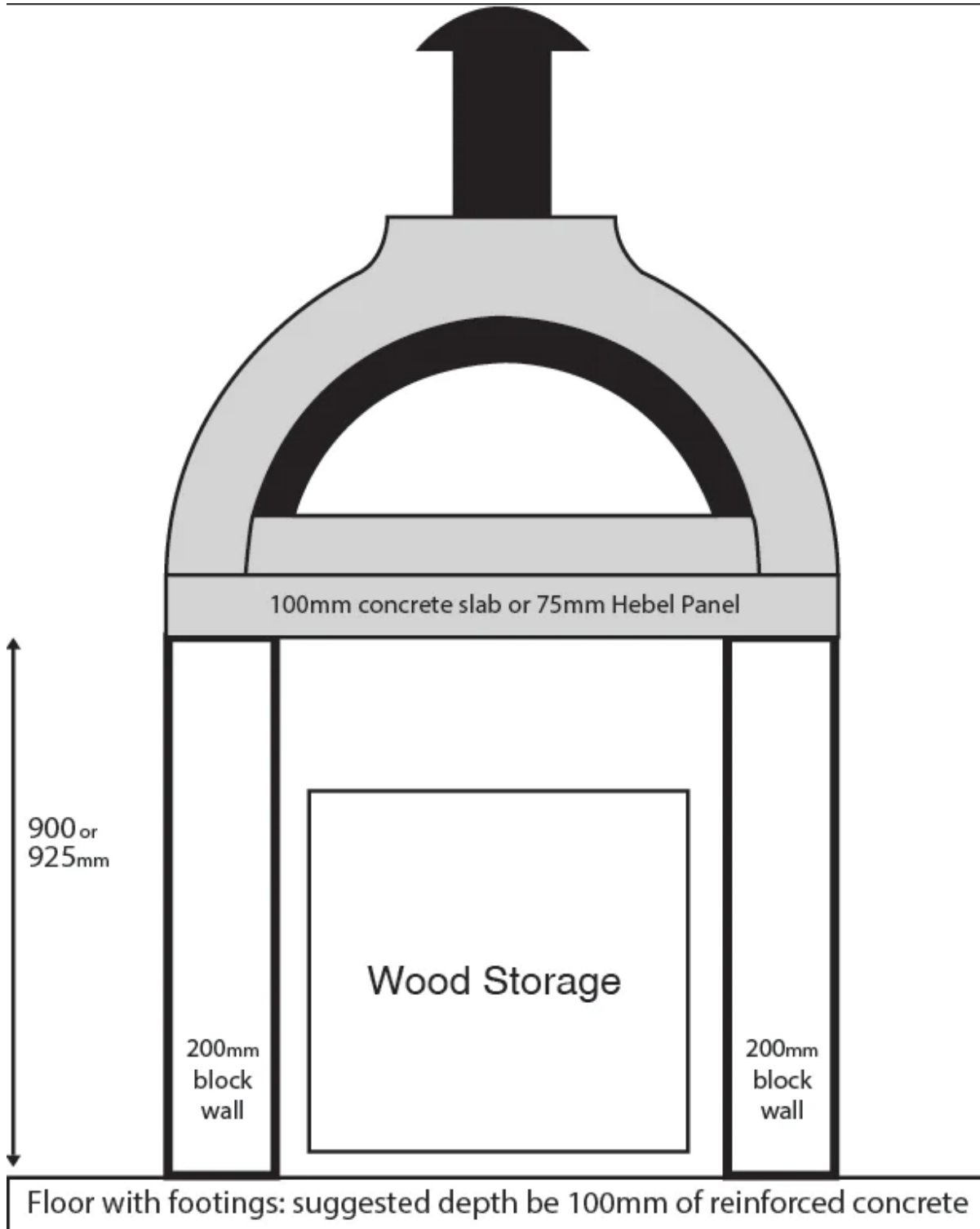

## CORNER DESIGN



## : Corner Design

200mm Re-inforced  
concrete footing

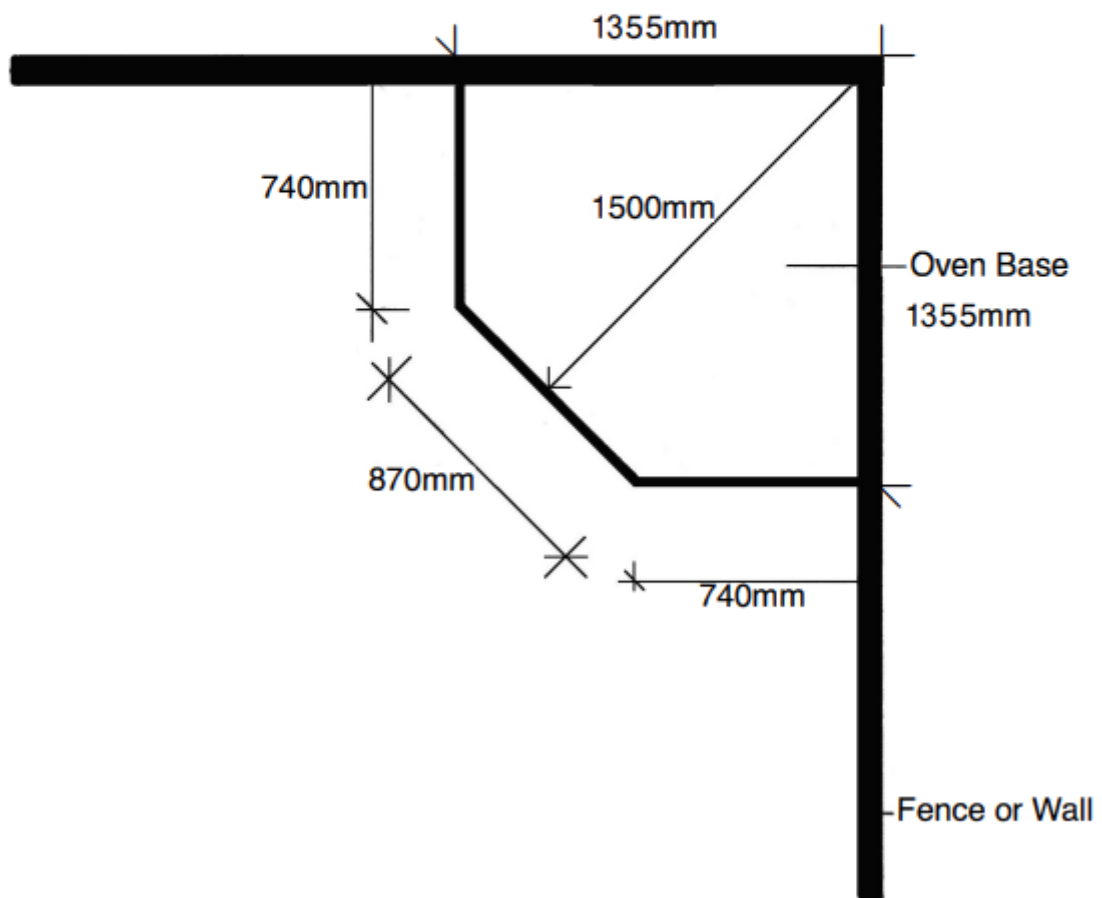

## PIZZA OVEN INSTRUCTIONS

### Firing (Curing & Seasoning)

#### **Curing your wood fired pizza oven for the first time:**

It is very important for the longevity of this product that the wood fired oven is 'seasoned or cured' correctly. When firing your oven for the first time, it is vital that heat be built up **gradually**.

We strongly recommend the use of heat beads or similar, as your heat source for seasoning your oven. These materials burn consistently, and enable you to take longer breaks in between inspecting and topping up your seasoning fire.

**Day 1.** Initially fire up a pile of charcoal beads or tablets approximately 20 cm diameter, so that it burns with a low, small flame. Keep this initial firing burning consistently for approximately 24 hours; (last to bed tops up the fire, as does the first to rise the next day- not allowing the oven to completely cool down at any time).

**Day 2.** Grow your pile of beads so that it now has an approximately 22 cm diameter; (once again maintain this fire as consistently as possible, for the second 24 hours of seasoning).

**Day 2/3 firing Day 3.** Grow your pile of beads so that it now has an approximately 30 cm diameter; (once again maintain this fire as consistently as possible, for the third 24 hours of seasoning).

Do not allow the flame to touch the inside surface of the oven dome during this first 72 hours.

This process is meant to gradually dry out and equalise the moisture content of the oven components. The process should therefore be not too rapid, not too hot, as the long-term performance of the oven may be affected.

**Ready for pizza Day 4.** Your final day of curing! During the course of day 4, keep gradually increasing the heat intensity of your fire. Towards the end of the fourth day, celebrate by adding hard wood logs, split in two or three, (approximately the size of shoe), so that your oven gets hot enough for pizzas. You can tell you have reached that temperature by observing that the inside surface of the oven should be near white in colour. Seasoning can then be considered finished.

***Important: Do not neglect this seasoning process, as the long-life and effective use of the oven may be compromised.***



## HELPFUL FIRING TIPS

### **How long should it take to fire up the oven?**

A domestic wood oven, dependant on size will range from 20 minutes to 1 hour depending on the size of the oven to achieve cooking temperature.

### **Should my oven produce smoke?**

Smoke at some stage in the firing process is completely normal. You can reduce the amount of smoke by using wood of a kindling size. Never the less, there is always at least one point where smoke is produced – as the flame's maximum temperature is reached, smoke is produced by expanding gases within the burning wood. At this stage, quite often the whole inside of the oven is also filled with flame.

### **What is the best wood to burn?**

Pine and general kindling is best to use to initiate the fire, then hard wood logs should be added to increase the temperature.

Do not use man-made woods (particle board, MDF &c), painted or glued timber, or timber that has been treated with chemicals (perma pine for example). Pine burns very quickly, but also quite hot, so pine may be used to fire the oven hot and fast.

### **What do I do once I start the fire?**

During firing the door is left open, allowing oxygen to help fuel the fire and allowing any smoke produced to escape through the flue.

Helpful wood fired oven cooking tips

### **What is the difference between cooking pizza and bread?**

Pizza is cooked at approximately 350°C and bread at 200°C approx

Directly after firing your oven is the best time to cook pizza, but if you want to continue cooking many pizzas, you will have to maintain the fire in the back or side(s) of the oven to keep the desired temperature. This is not too difficult, as most pizzas take between 2 or 3 minutes to cook.





If you wish to cook bread, the best thing to do after firing is to sweep out the embers once the oven has reached maximum temperature (the walls of the oven will be almost white hot) and then wait for the temperature to drop from 350° to around the 200°C required for most bread baking. This is where many people will cook a few pizzas while they wait for this temperature drop to occur.

As mentioned, generally cook on a falling heat – when the desired temperature is reached, place the food in the oven and cook. This principal remains the same even down to very low temperatures desired for drying fruit and herbs.

How the real wood-burning oven works

There are two cooking systems available using the same wood-burning oven:

The PIZZERIA system. With a hot oven and open oven door, you leave a little burning wood on one side of the oven. On the other side you cook the pizza, foccacia, bruschetta etc. directly on the oven's cooking surface.

The PANIFICIO system. You heat the oven to the desired temperature, burning all the wood inside. You put the food that is to be cooked in the oven, close the door and wait until it is cooked.

With this system you can cook roast meats and fish, bread, whole roasted pig and pastries.

### **How long does it take to cook a pizza in a wood fired oven?**

Our ovens cook perfect wood fired pizza in 2-3 minutes – we operate them at around 400C.

Yes, traditionally pizzas are cooked on the floor but of course you can still use trays. Our ovens are also designed with a low ceiling to force the heat onto the floor. Ovens with a high ceiling take longer to heat, longer to cook and use more firewood.

### **How long does the oven take to reach cooking temperature?**

The wood oven takes from 30 minutes to 90 minutes – depending on the size of the wood oven and when it was last used to prepare for cooking pizza (approx 400C). Roasting and baking bread are at much lower temperatures than pizza baking.





## PIZZA OVEN INSTRUCTIONS

Start fire in middle of oven with general kindling or pine to initiate the fire then use any hardwood logs to increase fire.

Leave the door open so oxygen will fuel the oven.

Ensure you use DRY wood. Never use treated or painted timber.

Establish the fire and build the heat for 30-60 minutes before cooking

Push the wood logs/fire to rear side of oven (back 1/3 corner of oven) once the fire is established to leave cooking floor surface available.

Build up the fire slowly, inside dome will turn white when ready to cook.

Ideally cook at 400-500c degrees (use a hand held infer red thermometer if required).

Do not make pizza dough too wet, try to sprinkle extra semolina flour under the pizza base. This will make it easier to slide the pizza base in and out of the oven on a paddle.

Cook with door open.

Turn pizzas around in the oven with a pizza paddle to evenly cook. Pizzas should take about 2-3 minutes to cook.

When finished cooking return the door and leave slightly a-jar so oven can breathe. When fire is dead and extinguished close the oven door.

After cooking with wood fire you can leave ash and any remaining logs in the back corner of the oven until the next time the oven is used.

However, when the ash builds up (every second time the oven is used) remove excess cool ash.

To remove excess ash allow the oven to COOL completely then brush out and remove the excess build up of cold ash. Brush out the oven to ensure the cooking surface is clean. There is no need to wet or wash the oven floor as the extreme heat will clean the oven floor.

[www.pizzaovensrus.com.au](http://www.pizzaovensrus.com.au) | [info@pizzaovensrus.com.au](mailto:info@pizzaovensrus.com.au) | 0402 551 467 | 1300 032 822



Australian Owned  
Business



Shipping  
Australia Wide



Expert Advice



Best Price  
Guaranteed