

## ASSEMBLY INSTRUCTIONS

### Option 1: Canopy Mounted Driver

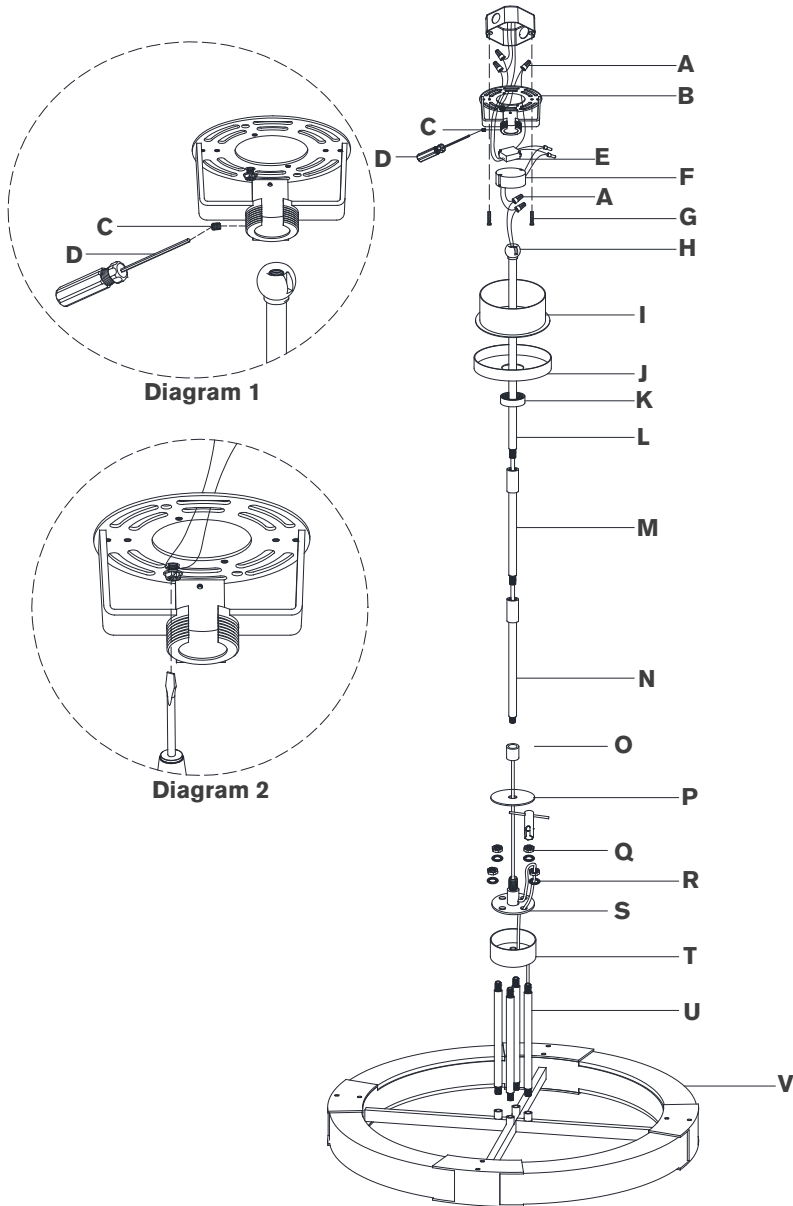

## Covet Medium Ring Chandelier

Item # KW 5138

### NOTICE:

This light fixture should be installed in accordance with all applicable, local installation codes, and by a person familiar with the construction and operation of it, as well as the hazards involved. Inspect item and contents carefully. If any damage or defect is found, do not install. Retain all packaging material until installation is complete and approved.

### TOOLS REQUIRED (NOT INCLUDED):

Phillips Screwdriver	Slotted Screwdriver	Wire Cutters
Wire Strippers	Slip-joint pliers	

1. Carefully remove all parts from the box. Place on a clean, soft surface.
2. Remove mounting plate **(B)** from driver housing **(I)** and canopy **(J)** by removing collar ring **(K)**.
3. Install mounting plate **(B)** to the junction box and secure with mounting screws **(G)**.
4. Thread rods **(U)** to fixture body **(V)**.
5. Let rods **(U)** pass through hub **(T)** and metal plate **(S)** and secure with washers **(R)** and hex nuts **(Q)** using provided wrench.
6. Install metal cap **(P)** to hub **(T)** and secure with connector **(O)**.
7. Feed electrical wires through bottom rod **(N)** and thread to connector **(O)**. Repeat for middle rod **(M)**, connecting to bottom rod **(N)**.
8. Continue feeding wires through collar ring **(K)**, canopy **(J)**, driver housing **(I)** and top rod **(L)**.
9. Holding fixture upright, slide collar ring **(K)**, canopy **(J)**, driver housing **(I)** down bottom rods **(N)** and rest on metal cap **(P)**. Then connect top rod **(L)** to middle rod **(M)**.

**NOTE:** Slide components down slowly to avoid damages.

## ASSEMBLY INSTRUCTIONS

### Option 1: Canopy Mounted Driver

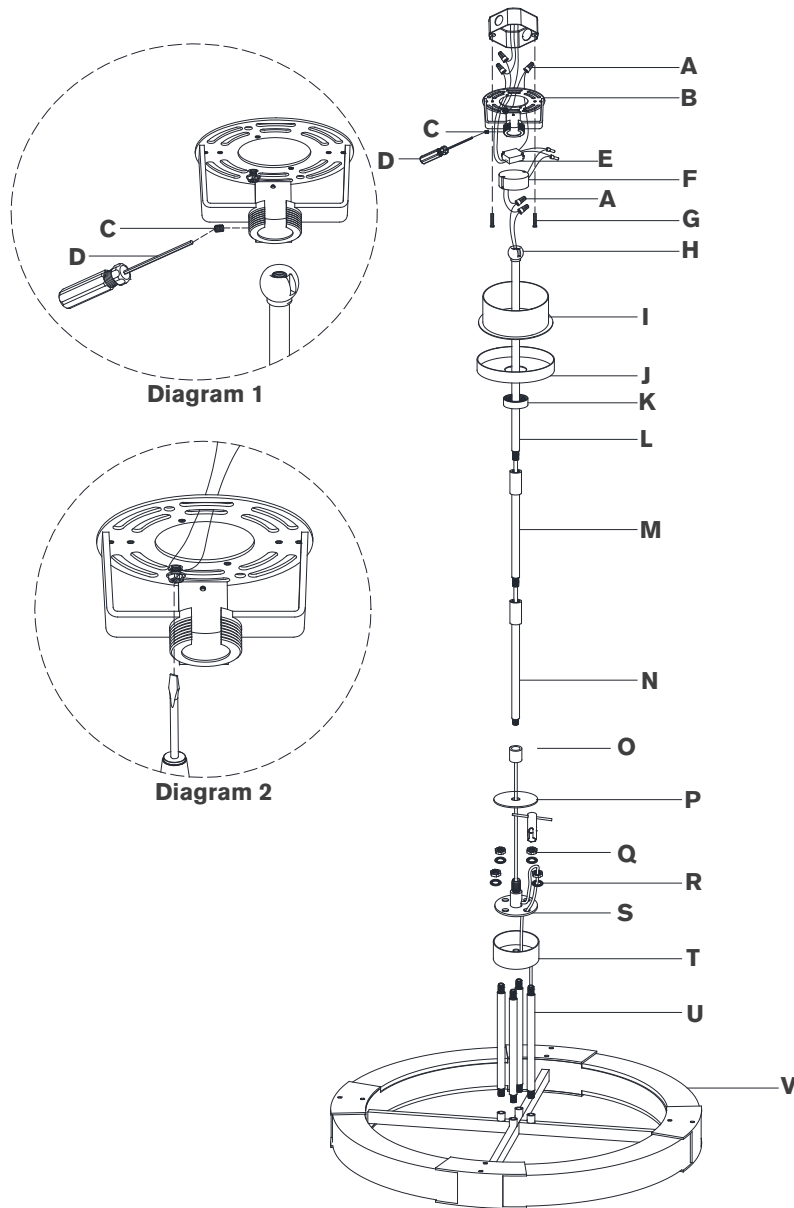

## Covet Medium Ring Chandelier

Item # KW 5138

### NOTICE:

This light fixture should be installed in accordance with all applicable, local installation codes, and by a person familiar with the construction and operation of it, as well as the hazards involved. Inspect item and contents carefully. If any damage or defect is found, do not install. Retain all packaging material until installation is complete and approved.

10. Hang fixture swivel ball (**H**) to the center of tall mounting plate (**B**) and secure with set screw (**C**) using provided screwdriver (**D**). See diagram 1.
  11. Cut excess wires, being sure to leave enough to reach the junction box. Separate wires, and strip insulation on each 5/8".
  12. Connect supply ground wire (usually green or bare copper) around the green grounding screw (see diagram 2). Tighten. Continue supply ground wire and connect to filter (**E**) ground wire (green/yellow) using wire nut (**A**).
- NOTE:** It is imperative that the fixture is grounded.
13. Connect filter (**E**) input neutral wire (white) to the supply neutral wire (usually white) using wire nut (**A**).
  14. Connect filter (**E**) input hot wire (black) to the supply hot wire (usually black) using wire nut (**A**).
- CAUTION:** Do not reverse the hot and neutral connections.
15. Connect fixture neutral wire (black) to driver (**F**) output wire (black) using wire nut (**A**).
  16. Connect fixture hot wire (red) to driver (**F**) output wire (red) using wire nut (**A**).
- CAUTION:** Do not reverse the hot and neutral connections.
17. Make sure all wire connections are tight, then carefully tuck into the junction box.
  18. Insert filter (**E**) and driver (**F**) into the center of tall mounting plate (**B**).
  19. Install driver housing (**I**) and canopy (**J**) to tall mounting plate (**B**) and secure with collar ring (**K**).

**Care Instructions:** Clean only with a soft dry cloth or feather duster. Do not use abrasive or chemical agents.

## ASSEMBLY INSTRUCTIONS

### Option 2: Ceiling Mounted Driver

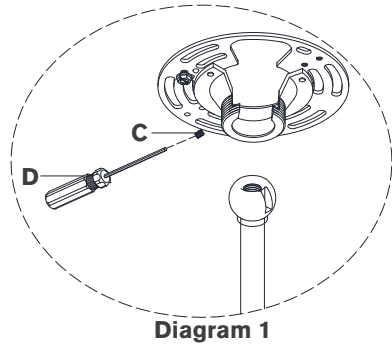

Diagram 1

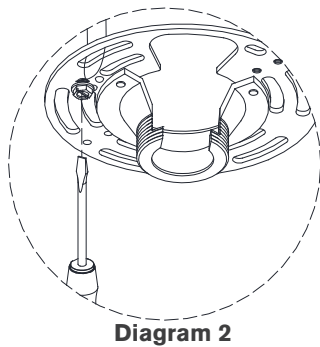
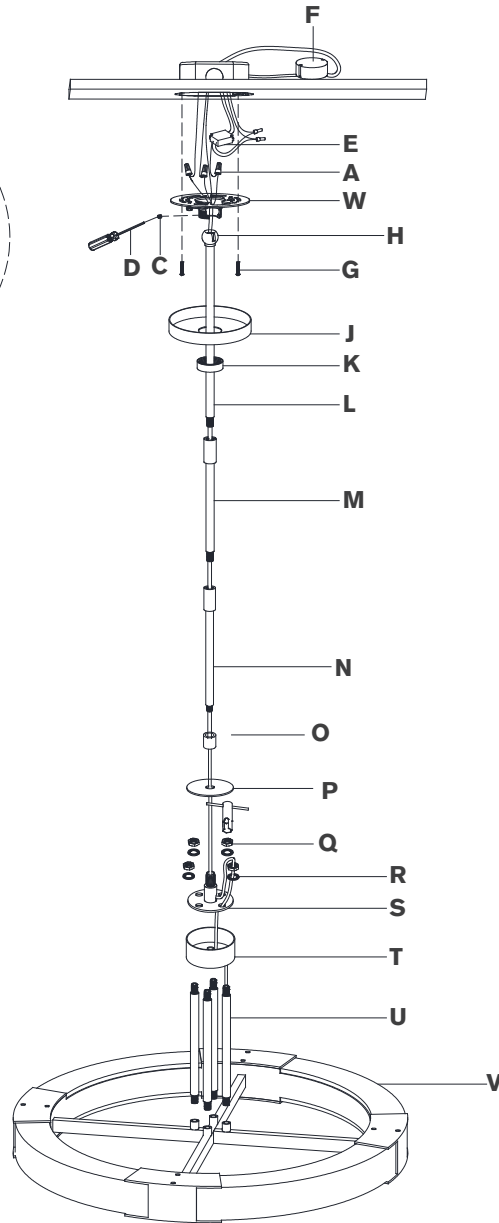

Diagram 2



## Covet Medium Ring Chandelier

Item # KW 5138

### NOTICE:

This light fixture should be installed in accordance with all applicable, local installation codes, and by a person familiar with the construction and operation of it, as well as the hazards involved. Inspect item and contents carefully. If any damage or defect is found, do not install. Retain all packaging material until installation is complete and approved.

### TOOLS REQUIRED (NOT INCLUDED):

Phillips Screwdriver	Slotted Screwdriver	Wire Cutters
Wire Strippers	Slip-joint pliers	

1. Carefully remove all parts from the box. Place on a clean, soft surface.
2. Place driver (**F**) into ceiling and route all wires through one of the knockouts in the junction box.
3. Remove mounting plate (**B**) from driver housing (**I**) and canopy (**J**) by removing collar ring (**K**).

**NOTE:** Driver housing (**I**) will be not be used for ceiling mounted assembly. Keep part and store for future use.

4. Install mounting plate (**W**) to the junction box and secure with mounting screws (**G**).
5. Thread rods (**U**) to fixture body (**V**).
6. Let rods (**U**) pass through hub (**T**) and metal plate (**S**) and secure with washers (**R**) and hex nuts (**Q**) using provided wrench (**P**).
7. Install metal cap (**P**) to hub (**T**) and secure with connector (**O**).
8. Feed electrical wires through bottom rod (**N**) and thread to metal plate (**S**). Repeat for middle rod (**M**), connecting to bottom rod (**N**).
9. Continue feeding wires through collar ring (**K**), canopy (**J**) and top rod (**L**).
10. Holding fixture upright, slide collar ring (**K**), canopy (**J**), driver housing (**I**) down bottom rods (**N**) and rest on metal cap (**P**). Then connect top rod (**L**) to middle rod (**M**).

**NOTE:** Slide components down slowly to avoid damages.

## ASSEMBLY INSTRUCTIONS

### Option 2: Ceiling Mounted Driver

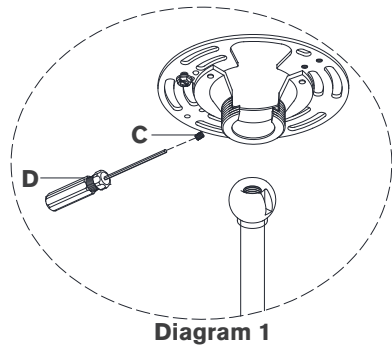

Diagram 1

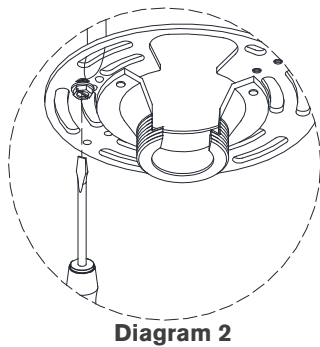
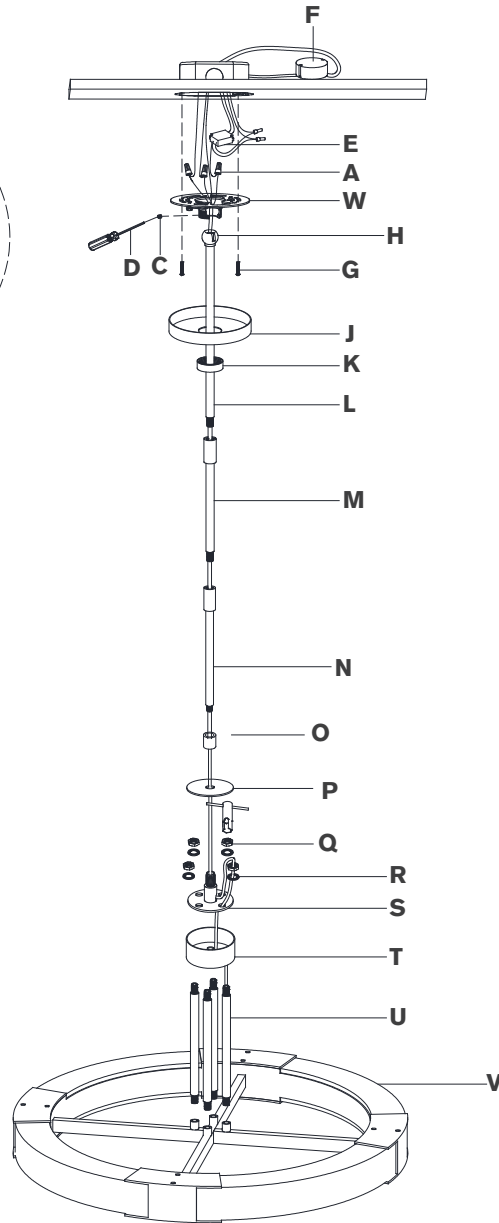

Diagram 2



## Covet Medium Ring Chandelier

Item # KW 5138

### NOTICE:

This light fixture should be installed in accordance with all applicable, local installation codes, and by a person familiar with the construction and operation of it, as well as the hazards involved. Inspect item and contents carefully. If any damage or defect is found, do not install. Retain all packaging material until installation is complete and approved.

11. Hang fixture swivel ball (**H**) to the center of tall mounting plate (**B**) and secure with set screw (**C**) using provided screwdriver (**D**). See diagram 1.
12. Cut excess wires, being sure to leave enough to reach the junction box. Separate wires, and strip insulation on each 5/8".
13. Connect supply ground wire (usually green or bare copper) around the green grounding screw (see diagram 2). Tighten. Continue supply ground wire and connect to filter (**E**) ground wire (green/yellow) using wire nut (**A**).  
**NOTE:** It is imperative that the fixture is grounded.
14. Connect filter (**E**) input neutral wire (white) to the supply neutral wire (usually white) using wire nut (**A**).
15. Connect filter (**E**) input hot wire (black) to the supply hot wire (usually black) using wire nut (**A**).  
**CAUTION:** Do not reverse the hot and neutral connections.
16. Connect fixture neutral wire (black) to driver (**F**) output wire (black) using wire nut (**A**).
17. Connect fixture hot wire (red) to driver (**F**) output wire (red) using wire nut (**A**).  
**CAUTION:** Do not reverse the hot and neutral connections.
18. Make sure all wire connections are tight, then carefully tuck into the junction box.
19. Insert filter (**E**) and driver (**F**) into the center of tall mounting plate (**B**).
20. Install canopy (**J**) to short mounting plate (**W**) and secure with collar ring (**K**).

**Care Instructions:** Clean only with a soft dry cloth or feather duster. Do not use abrasive or chemical agents.