

INFINITA

Design Renato Toso, Noti Massari & Associati

INFINITA SP 80



Available as pendant or ceiling lamp. A response to a growing demand for large lamps with multiple sockets. Its main advantage is a considerable lighting surface with a minimum metal body.

INFINITA SP 80

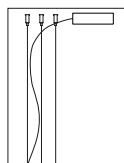
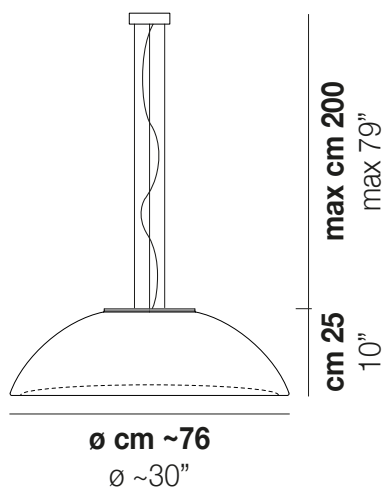

TECHNICAL DATA:



CERTIFICATIONS:



LIGHT SOURCES

5x60W 120V/60HZ E26



1x19,5W 39 V

Led 2700 K 19,5 W 39 V 2850 lm DIM3 0-10V, Push

VOLUME Mc 0,47
GROSS WEIGHT Kg 23
NET WEIGHT Kg 18

[download](#)



SHADE FINISHING



BCST

FRAME FINISHING



BC

OTHER VERSION AVAILABLE

Click on the version to go to the web version of the product

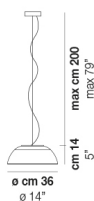

INFIN SP 36

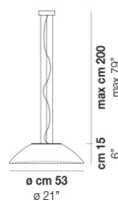

INFIN SP 53