

**Pablo®**

# BOLA

SPHERE FLUSH

USER GUIDE

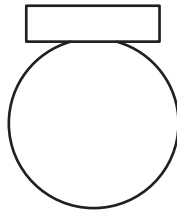

[pablodesigns.com](http://pablodesigns.com)

Pablo®

# BOLA SPHERE FLUSH

## CONTENTS

- A. GLOBE DIFFUSER
- B. LIGHT ENGINE
- C. CANOPY
- D. MOUNT BRACKET
- E. DRIVER

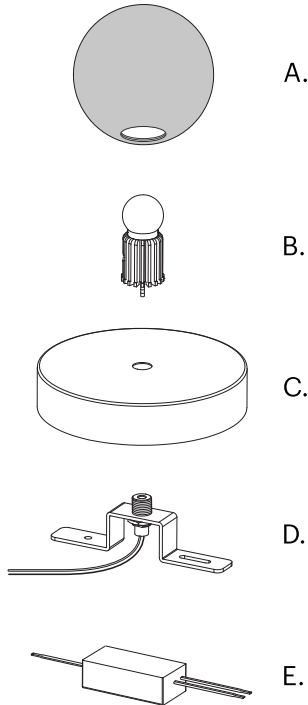

## SPECIFICATIONS

HIGH-OUTPUT CHIP ON BOARD  
POWER CONSUMPTION: 6W(4",5"), 12W(6"), 20W(8",10",12")  
COLOR TEMP: 2700-1800K WARM DIM  
LUMINOSITY: 290LM(4",5"), 800LM(6"), 1625LM(8",10",12")



## CARE INSTRUCTIONS

WIPE SHADES WITH SOFT CLOTH. AVOID AMMONIA BASED CLEANERS.

## DE: INHALT

- A. KUGELDIFFUSOR
- B. LICHTMOTOR
- C. ÜBERDACHUNG
- D. MONTAGEHALTERUNG
- E. FAHRER

## SPEZIFIKATIONEN

HOCHLEISTUNGSCHIP AN BORD  
STROMVERBRAUCH: 6 W (4 ZOLL, 5 ZOLL), 12 W (6 ZOLL), 20 W  
(8 ZOLL, 10 ZOLL, 12 ZOLL)  
FARBTEMPERATUR: 2700-1800K WARM DIM  
LEUCHTKRAFT: 290LM (4",5"), 800LM (6"), 1625LM (8",10",12")



## PFLEGEHINWEISE

WISCHEN SIE DIE FARBTÖNE MIT EINEM WEICHEN TUCH AB. VERMEIDEN  
SIE REINIGUNGSMITTEL AUF AMMONIAKBASIS.

## FR: CONTENU

- A. GLOBE DIFFUSEUR
- B. MOTEUR LUMINEUX
- C. AUVENT
- D. SUPPORT DE MONTAGE
- E. CONDUCTEUR

## CARACTÉRISTIQUES

PUCE À HAUT RENDEMENT INTÉGRÉE  
CONSOMMATION ÉLECTRIQUE : 6W(4",5"), 12W(6"),  
20W(8",10",12")  
TEMPÉRATURE DE COULEUR: 2700-1800K WARM DIM  
LUMINOSITÉ : 290LM(4",5"), 800LM(6"), 1625LM(8",10",12")



## ISTRUZIONI D'ENTRETIEN

ESSUYEZ LES TEINTES AVEC UN CHIFFON DOUX. ÉVITEZ LES NETTOYANTS À BASE D'AMMONIAC.

## IT: CONTENUTI

- A. DIFFUSORE GLOBO
- B. MOTORE LEGGERO
- C. TETTOIA
- D. STAFFA DI MONTAGGIO
- E. CONDUCENTE

## SPECIFICHE

CHIP A BORDO AD ALTO RENDIMENTO  
CONSUMO ENERGETICO: 6W(4",5"), 12W(6"), 20W(8",10",12")  
TEMP. COLORE: 2700-1800K CALDO DIM  
LUMINOSITÀ: 290LM(4",5"), 800LM(6"), 1625LM(8",10",12")



## ISTRUZIONI PER LA CURA

PULIRE LE TONALITÀ CON UN PANNINO MORBIDO. EVITA I DETERGENTI A BASE DI AMMONIACA.

# BOLA SPHERE FLUSH

1.

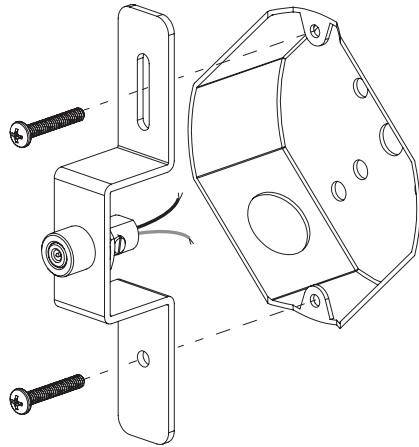

2.

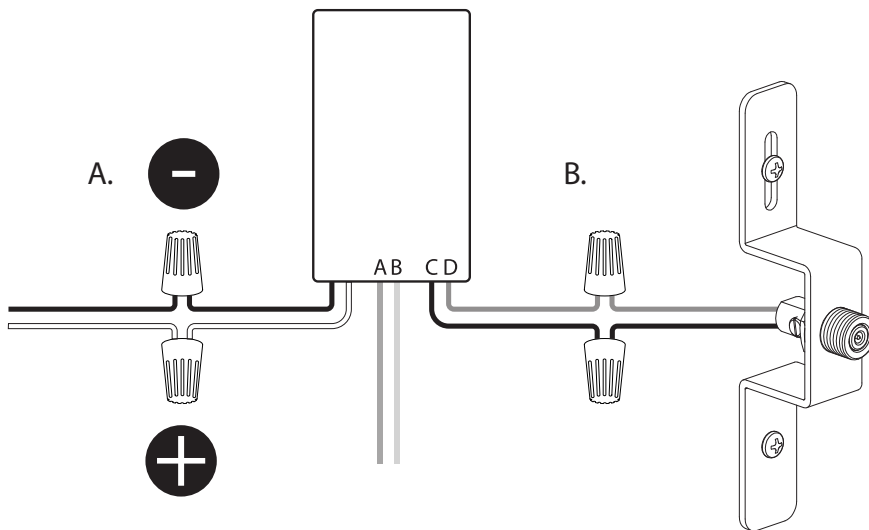

## EN: ASSEMBLY

1. SECURE MOUNT BRACKET TO JUNCTION BOX OR CEILING.
2. A. WIRE DRIVER TO BUILDING (US: WHITE TO WHITE/BLACK TO BLACK)(EU: + TO WHITE/- TO BLACK)
- B. WIRE DRIVER TO LAMP (C-BLUE TO BLACK/D-RED TO RED)

## DE: MONTAGE

1. BEFESTIGEN SIE DIE HALTERUNG AM ANSCHLUSSKASTEN ODER AN DER DECKE.
2. A. TREIBER ZUM GEBÄUDE VERKABELN (USA: WEIß ZU WEIß/SCHWARZ ZU SCHWARZ)  
(EU: + ZU WEIß/- ZU SCHWARZ)
- B. DRAHTTREIBER ZUR LAMPE (C-BLAU ZU SCHWARZ/D-ROT ZU ROT)

## FR: ASSEMBLÉ

1. FIXEZ LE SUPPORT DE MONTAGE À LA BOÎTE DE JONCTION OU AU PLAFOND.
2. A. WIRE DRIVER TO BUILDING (USA : BLANC À BLANC/NOIR À NOIR)  
(EU : + À BLANC/- À NOIR)
- CONDUCTEUR DE B. WIRE À LA LAMPE (C-BLEU AU NOIR/D-ROUGE AU ROUGE)

## IT: MONTAGGIO

1. FISSARE LA STAFFA DI MONTAGGIO ALLA SCATOLA DI GIUNZIONE O AL SOFFITTO.
2. A. WIRE DRIVER TO BUILDING (USA: BIANCO A BIANCO/NERO A NERO)  
(EU: + A BIANCO/- A NERO)
- B. WIRE DRIVER ALLA LAMPADA (C-BLU AL NERO/D-ROSSO AL ROSSO)

# BOLA SPHERE FLUSH

3.

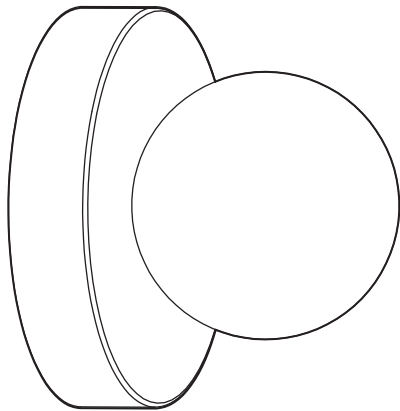
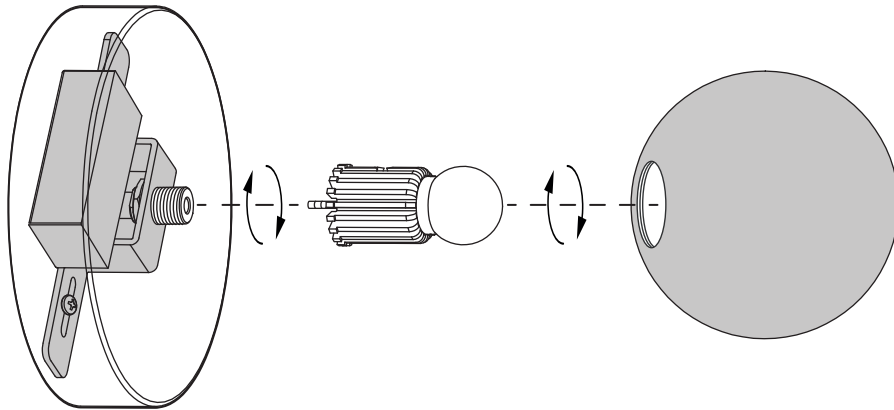

**EN: ASSEMBLY**

3. ENCLOSE DRIVER WITH CANOPY COVER AND THREAD ON LIGHT ENGINE AND GLOBE DIFFUSER AS DEMONSTRATED.

**DE: MONTAGE**

3. SCHLIEßEN SIE DEN TREIBER MIT DER BALDACHINABDECKUNG AN UND SCHRAUBEN SIE IHN WIE GEZEIGT AUF DIE LICHTMASCHINE UND DEN KUGELDIFFUSOR.

**FR: ASSEMBLÉ**

3. ENFERMEZ LE CONDUCTEUR AVEC LA COUVERTURE D'AUVENT ET LE FIL SUR LE MOTEUR LÉGER ET LE DIFFUSEUR DE GLOBE COMME DÉMONTRÉ.

**IT: MONTAGGIO**

3. ENCLUDERE IL DRIVER CON LA COPERTURA DEL TETTuccio E INFILARE IL MOTORE DELLA LUCE E IL DIFFUSORE DEL GLOBO COME MOSTRATO.

**Pablo<sup>®</sup>**

INFO@PABLODESIGNS.COM  
INFO@PABLODESIGNS.EU

888 MARIN ST  
SAN FRANCISCO, CA  
94124

PABLODESIGNS.COM  
PABLODESIGNS.EU