

Assembly Instructions

Mobius Floor Lamp 23-4505 & 23-4505C

C35

Page 1 of 7

Prepare Base (Figures 1 & 2)

Component Parts

- A 8-32 Screw (2)
- B Wireway Cover Plate
- C Base
- D Lower Pipe Assembly
- E Threaded Stud (4)
- F Hex Nut (4)

1. Carefully unpack the lamp from the carton. The lamp has been packaged with the cord routed through the various parts of the lamp. Take care not to damage the cord when removing the lamp from the packaging.
2. Remove two 8-32 screws (A) holding wireway cover plate (B) to fixture. Set all parts to the side for later use.
3. Slip base (C) over lower pipe assembly (D) allowing the four threaded studs (E) to slip thru the four holes in the lower pipe assembly (D).
4. Install four hex nuts (F) onto threaded stud (E) and tighten.

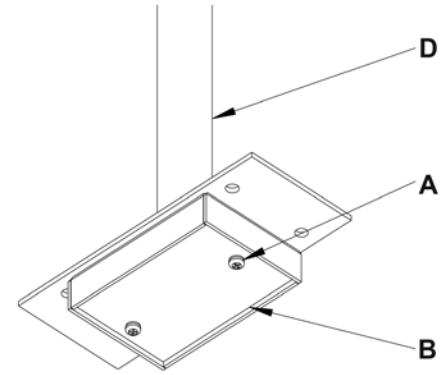

(Figure 1)

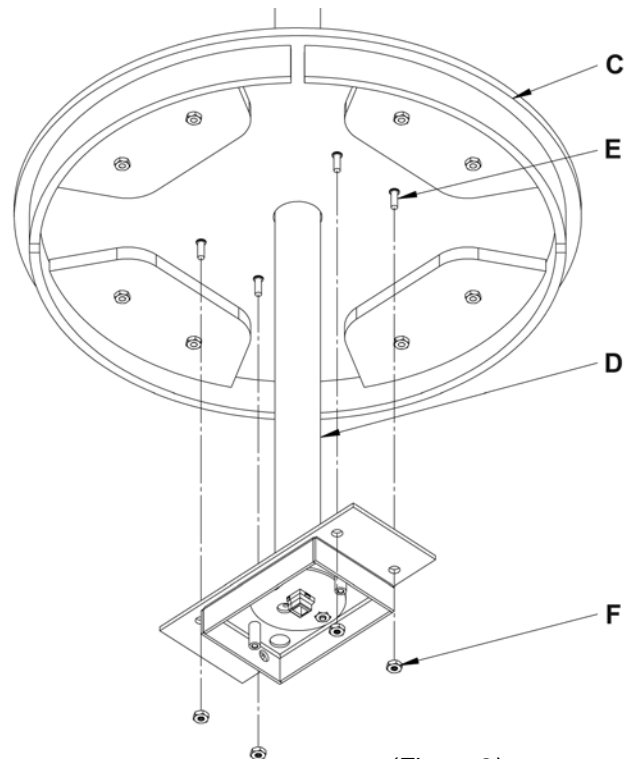

(Figure 2)

Assemble Mid-Section (Figure 3)

Component Parts

- G Arm Assembly
- H Tube Assembly

1. Thread arm assembly (G) to tube assembly (H), be certain not to twist the cord.



(Figure 3)

(continued)

Assembly Instructions

Mobius Floor Lamp 23-4505 & 23-4505C

C35

Page 2 of 7

Assemble (Figure 4)

Component Parts

- I Upper Assembly
- J Base Assembly
- K Coiled wire

1. Slip upper assembly (I) into base assembly (J).
2. Lower upper assembly (I) as far into the base assembly (J) so the coiled wire (K) with the connector comes out into the wireway area in the base.

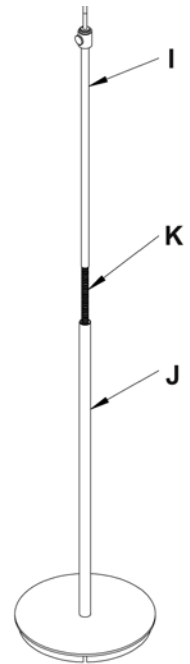

(Figure 4)

Complete Wiring in the Base (Figures 5 & 6)

Component Parts

- A 8-32 Screw (2)
- B Wireway Cover Plate
- F Hex Nut (2)
- J Base Assembly
- K Coiled wire
- L Strain Relief
- M Cover Plate
- N Male Quick Connect
- O Female Quick Connect

1. Remove cover plate (M) by loosening and removing two hex nuts (F) from base assembly (J). *Save for later use.*
2. Pull coiled wire (K) with male quick connect (N) and two wire crimps from the center of the fixture and push through the cover plate (M).
3. Snap strain relief (L) into cover plate (M).
4. Replace cover plate (M) and the two hex nuts (F). Tighten hex nuts until snug.
5. Plug the male quick connect (N) into the female quick connect (O).
6. Replace the wireway cover plate (M) and the two 8-32 screws (A) (Figure 6, next page).

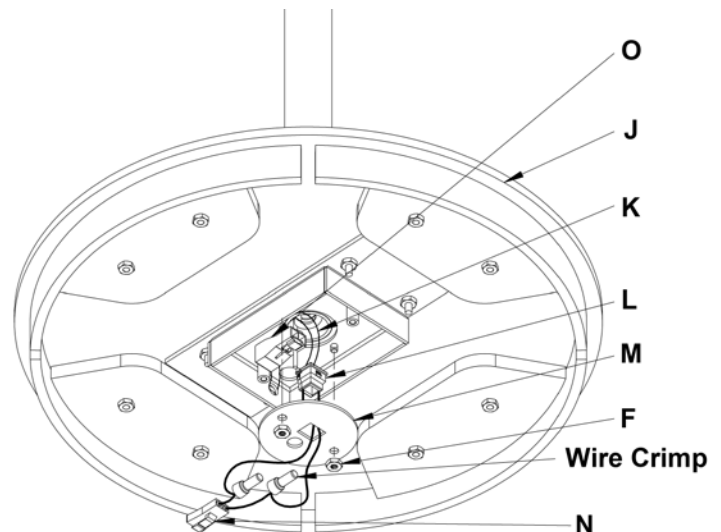

(Figure 5)

(continued)

Assembly Instructions

Mobius Floor Lamp 23-4505 & 23-4505C

C35

Page 3 of 7

Install Shade (Figure 7)

Component Parts

- P Retaining Ring
- Q Socket
- R Shade Assembly

1. Refer to instructions beginning on next page to assemble shade.
2. Remove retaining ring (P) from socket (Q).
Retaining ring is shipped installed.
3. Slip shade assembly (R) over socket (Q).
4. Thread retaining ring (P) onto socket (Q).
5. Install light bulb. (*"C" version bulb is included*)

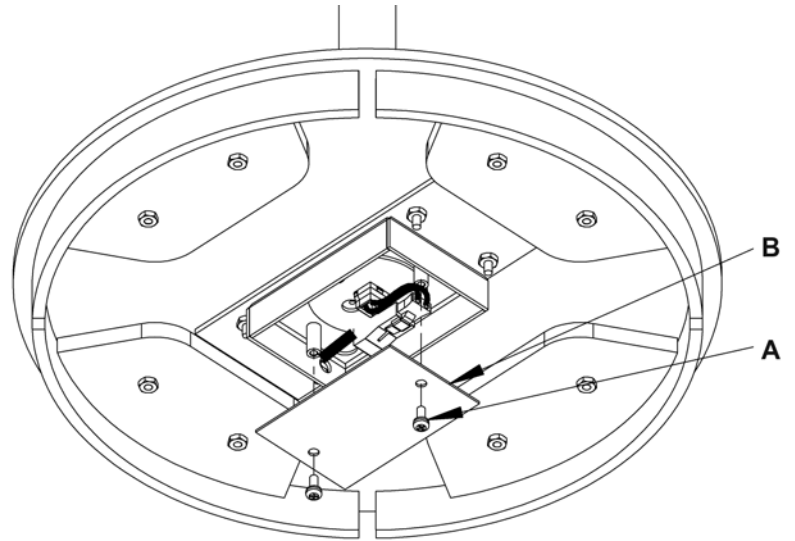

(Figure 6)

To Raise and Spin Fixture (Figure 8)

Component Parts

- I Upper Assembly
- J Base Assembly
- S Thumb Screw

1. Loosen thumb screw (S) and holding onto the base assembly (J) raise the upper assembly to desired height. The upper assembly will also spin at this point. Note: There is an internal stop inside the base assembly to prevent the upper assembly from turning repeatedly.
2. Once height and location is determined tighten thumb screw (S) and set screw below it.

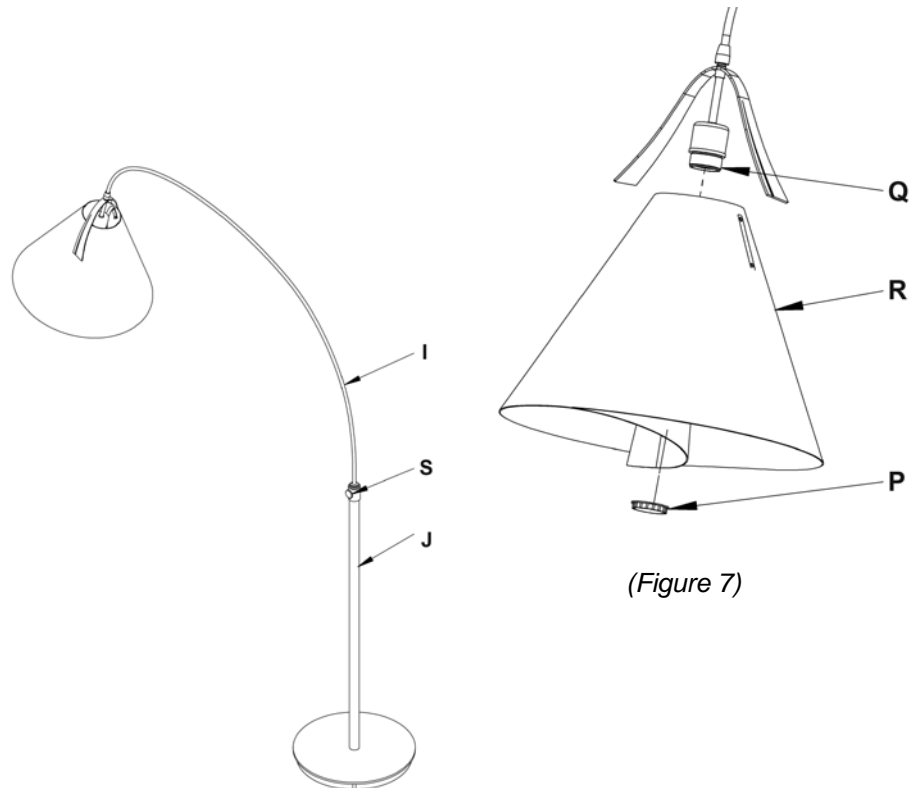

(Figure 7)

(Figure 8)

(continued)



To see a video on how to assemble the Mobius shade, go to:

<http://www.youtube.com/user/HubbardtonForge?v=ue3yX8f4iKc>

Assemble Shade

Component Parts

- T Shade Spider
- U Flat Shade Panel
- V Bracket with Studs (2)
- W Knobs (4)

Step 1 Identify all parts needed.

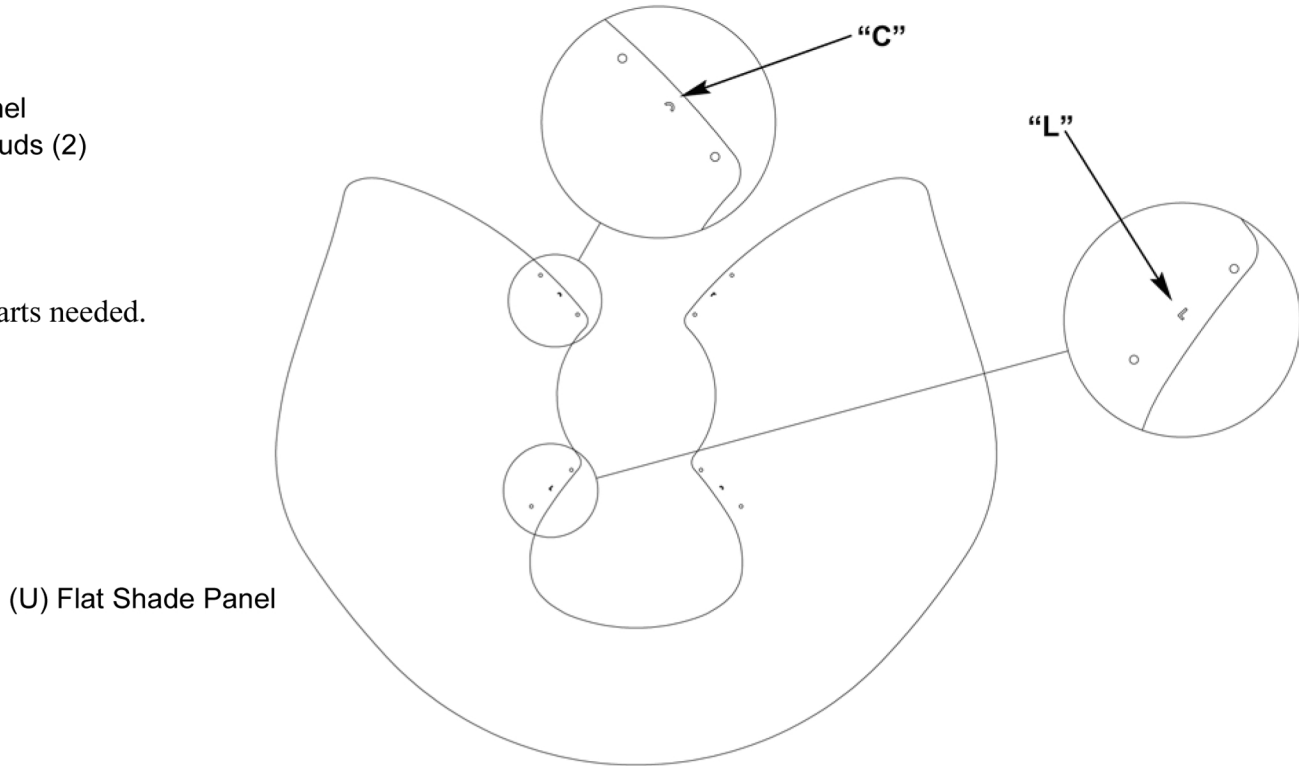

(T) Shade Spider

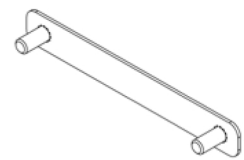
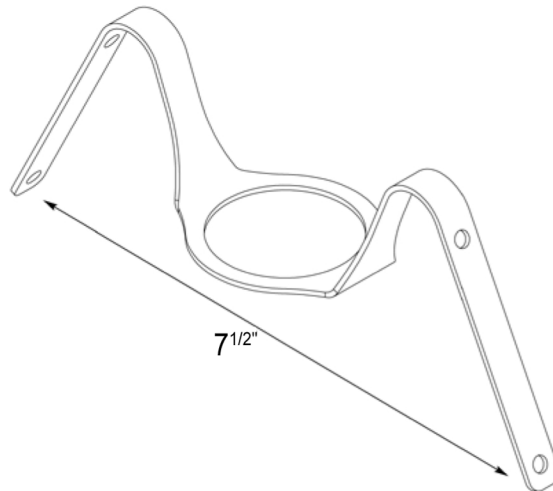

(V) Bracket with Studs (2)



(W) Knobs (4)

Note: It may be necessary to form shade spider to original width after shipment.

(continued)

Assembly Instructions

Mobius Floor Lamp 23-4505 & 23-4505C

C35

Page 5 of 7

Step 2 Fold shade panel over and align the letter designations "C".

Note: Top letter "C" should be oriented the same as bottom letter "C".



Step 3 Slip bracket with studs (S) through the "C" side of the shade panel (R).



Shade panel should appear like this.

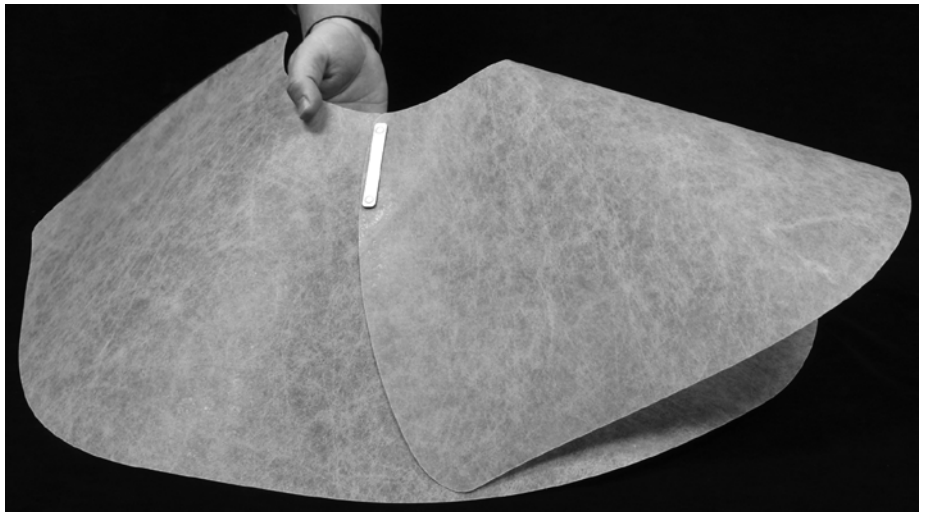

(continued)

Assembly Instructions

Mobius Floor Lamp 23-4505 & 23-4505C

C35

Page 6 of 7

Step 4 Flip shade panel (R) over and install shade spider (Q) onto the two studs.



Step 5 Install knobs (T) onto the two studs.



Step 6 Match the two "L" sides together.



Assembly Instructions

Mobius Floor Lamp 23-4505 & 23-4505C

C35

Page 7 of 7

Step 7 Fold the shade panel (r) with the bracket (S) and studs towards the shade spider (Q) and push the studs through the holes in the shade panel (R) and out through the spider (Q) on the inside.



Step 8 Install knobs (T).

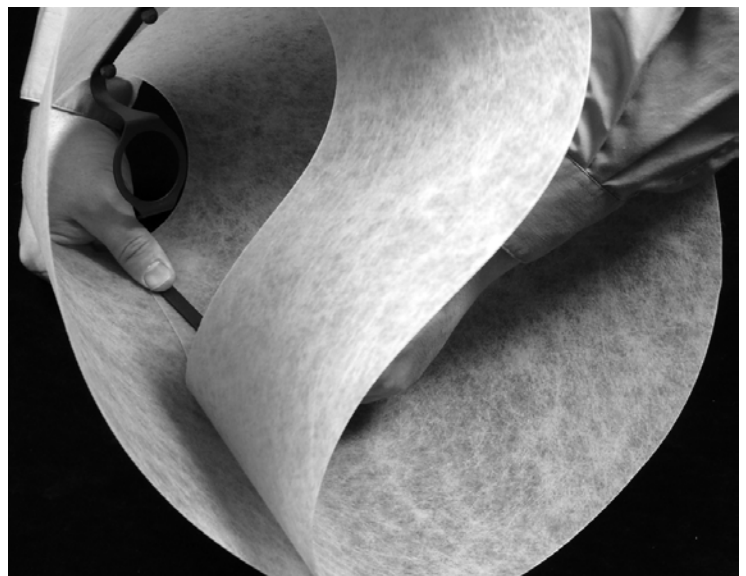

Complete assembled shade.

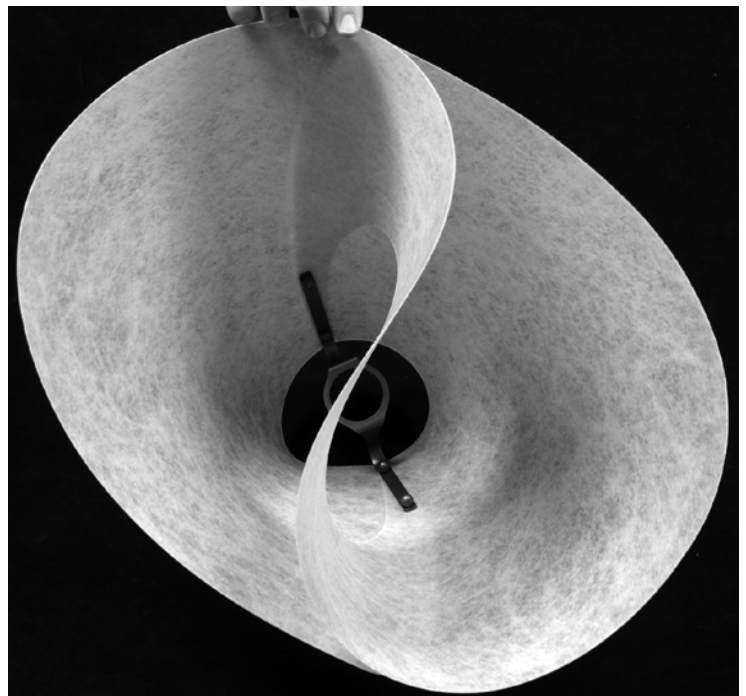

If you need further assistance, or find that you are missing any parts, please contact the dealer from which you purchased this product. We hope you enjoy your fixture!

* Hubbardton Forge will not be liable for injury or damage caused by improper installation, lamping or use of this fixture.

This portable lamp has a polarized plug (one blade is wider than the other). As a safety feature this plug will fit in a polarized outlet only one way. If the plug does not fit fully in the outlet, reverse the plug. If it still does not fit, contact a qualified electrician.

Never use with an extension cord unless plug can be fully inserted.

Do not attempt to defeat this safety feature.

Indications Importantes De Securite

Cette lampe portative a une prise de courant polarisee (une fiche est plus large que l'autre). Par mesure de securite, cette prise ne s'engagera dans une prise polarisee que dans un seul sens. Si la prise ne s'engage pas completement, faites renverser la prise. Si elle n'engage toujours pas, contactez un electricien competent.

Ne l'utilisez avec un prolongateur que si la prise s'engage completement.

N'essayez pas de toucher a cette mesure de securite.

A note about California State Statute Title 20



The California Energy Commission has established the Title 20 Code of Regulations. This statute's primary intention is to reduce energy consumption in the home.

Title 20 requires that all portable lamps sold within the State of California after January 1, 2010 shall have high efficiency lighting sources. The statute allows for a number of compliance options including Compact Fluorescent Bulbs (CFL), LED light sources, and the new GU-24 lighting platform.

Your product will include one of these new lighting sources as a result of Hubbardton Forge's compliance with California's Title 20.

For additional information regarding the California Statute Title 20, please refer to the California energy website <http://www.energy.ca.gov/siting/title20>.