

Collection: ROCK CRYSTAL

Product #: PLB0050-09

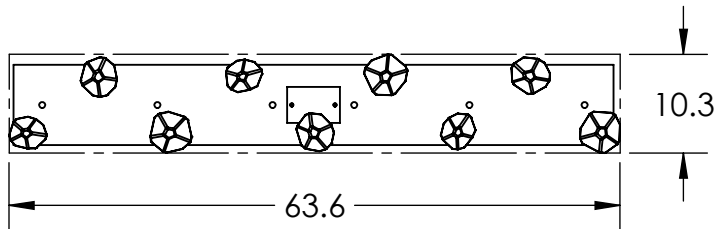
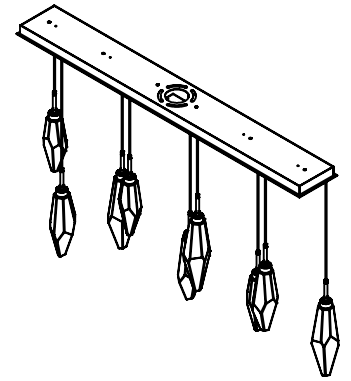
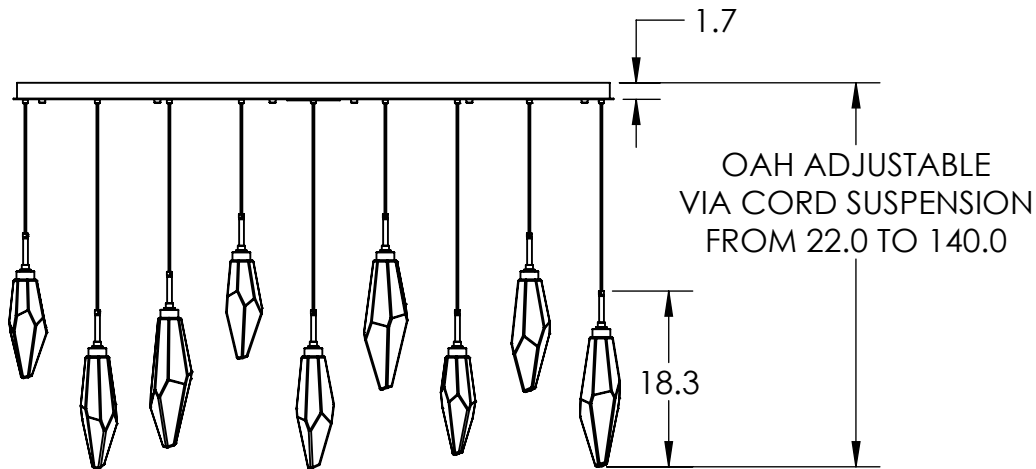

ROCK CRYSTAL COUNT

3 SMALL

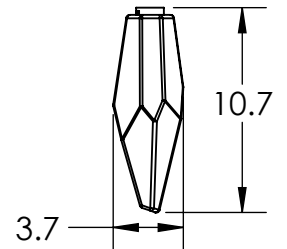

3 MEDIUM

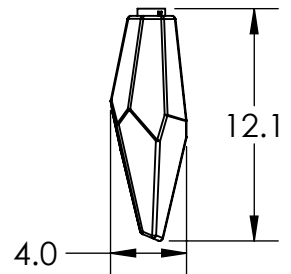

3 LARGE

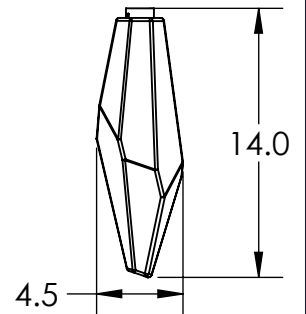

Visit hammertonstudio.com for product options and specifications.

4/25/2018 (A)

Mounting Packet: R	Weight(lbs.): 65	Electrical Type: LED	CCT: 2700 K	Mounting Detail
UL Location: DRY		Elec. Qty: 9	Wattage: 47	
Finish: SEE WEB SITE FOR OPTIONS		Source Lumens: 3080	DOWN	<p>62.5</p> <p>8.4</p> <p>Ø 5.5 BOLT CIRCLE</p>
Top Diffuser: CLOSED GLASS		Dimmable: Forward/Reverse Phase to 1%		
Bottom Diffuser: CLOSED GLASS		CRI: 93+	Power Factor: >0.9	
All fixtures created by Hammerton are handcrafted by artisans. Dimensions may vary up to 7/8".				
© Copyright 2018. All rights in design, detail or invention of this drawing are reserved as the property of Hammerton. Any imitation or adaptation without written consent is strictly prohibited.				
Hammerton Inc. 217 Wright Brothers Dr. Salt Lake City, UT 84116 (801)973-8095				MOUNTS TO BUILDING STRUCTURE