

Collection: DOWNTOWN

Product #: CHB0020-05-L1

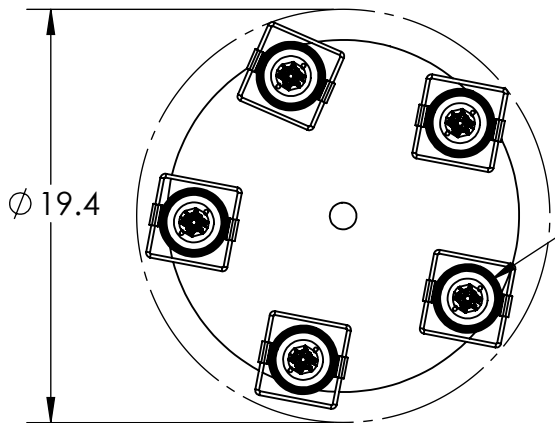
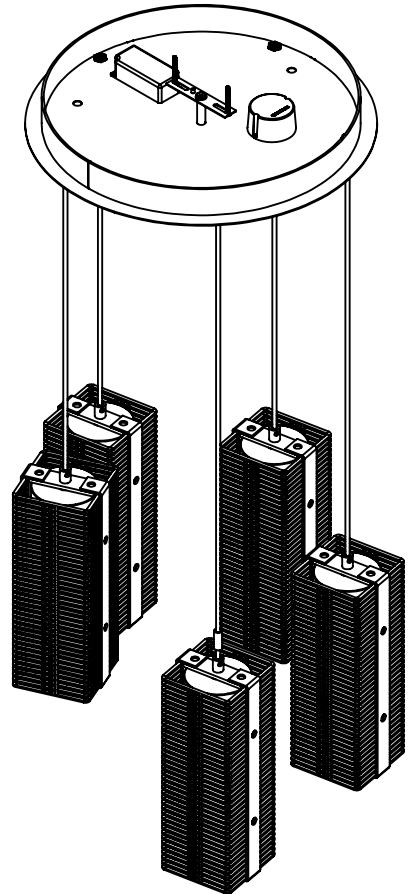
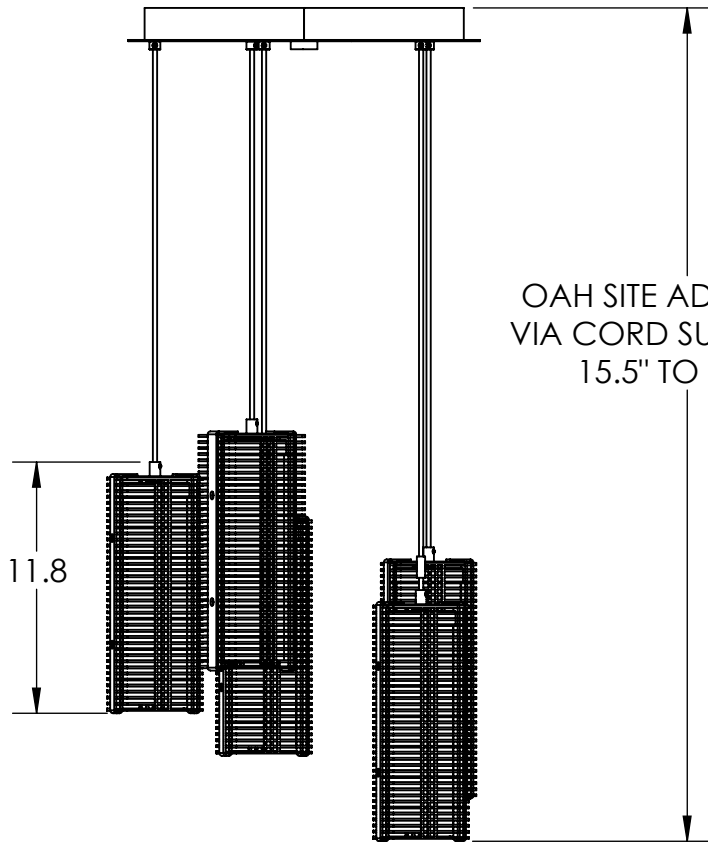

FROSTED GLASS CYLINDER
Ø 3" X 10" TALL

All dimensions are shown in inches unless otherwise stated.
Visit hammertonstudio.com for product options.

11/20/2019 (A)

Mounting Packet: W	Weight(lbs.): 38	Electrical Type: LED	CCT: 2700 K
UL Location: DRY	Elec. Qty: 5	Wattage: 26	Voltage: 120
Finish: SEE WEB SITE FOR OPTIONS	Source Lumens: Up: N/A	Down: 1710	
Top Diffuser: OPEN	Dimmable: Forward/Reverse Phase To 1%		
Bottom Diffuser: OPEN	CRI: 93+	Power Factor: >0.9	

Canopy Mounting Detail

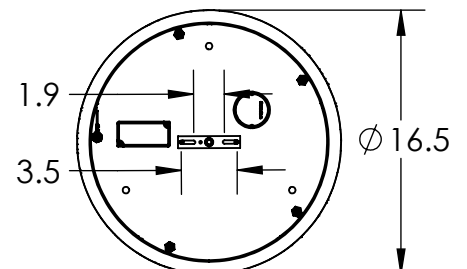

MOUNTS DIRECTLY TO J-BOX

All fixtures created by Hammerton are handcrafted by artisans. Dimensions may vary up to 7/8".

© Copyright 2019. All rights in design, detail or invention of this drawing are reserved as the property of Hammerton. Any imitation or adaptation without written consent is strictly prohibited.

Hammerton Inc. 217 Wright Brothers Dr. Salt Lake City, UT 84116 (801)973-8095