



## The Standard - Original 1933™ Design Model: CL01



An icon in its own right! The Standard Collection features the original Coolicon® shade as first produced and a larger companion model. An extensive palette of rich and vibrant colour ensures Coolicon® Standard enhances all settings.

The Original 1933™ Design is a small elegant shade with a curvaceous form and a very human scale. This stunning and versatile hand enamelled pendant shade can be used on its own or in clusters and rows to create statement lighting.



## Table of contents

Dimensions	3
Colours	3
Weight	4
Handmade process   Materials	4
Maintenance   Care	4
Mounting Indications	5
Conformance   Regulatory	5

### Important

- For indoor use only - IP depending on the electrical fittings
- Shade must be secured between lamp holder and shade ring(s)
- Not intended for use in Bathroom or installation in Wiring zones 0, 1 or 2
- All power to the circuit must be switched off at supply source before installation
- Installation to be carried out by a competent professional in accordance with current building regulations
- Electric cord and connection terminals must be relieved from strain with suitable cord grip and strain relief product
- Ensure luminaire electric cord is minimum 0.75mm<sup>2</sup>CSA and double insulated
- Always consider the total weight load when installing and suspending your Coolicon® shade
- Maintain safe distance between luminaire and surfaces



The Standard - Original 1933™ Design  
Model: CL01

### Dimensions

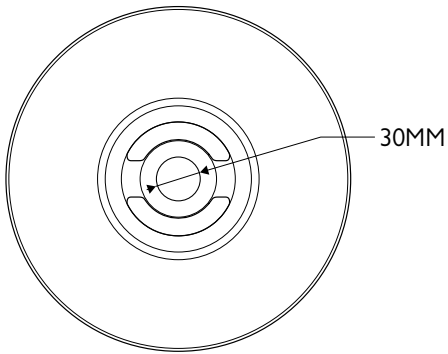

TOP

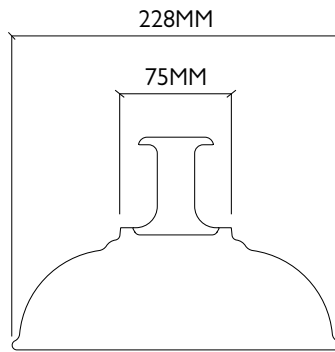

SIDE

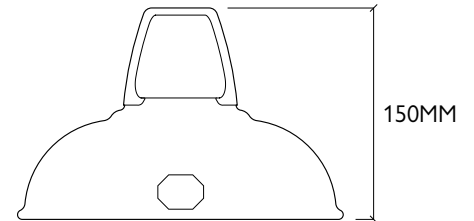

FRONT

### Colours

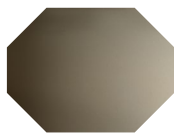

ANTINIUM

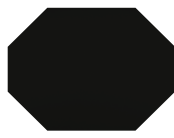

JET  
BLACK



ROYAL  
BLUE



CLASSIC  
CREAM



ORIGINAL  
GREEN

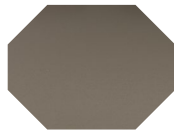

ORIGINAL  
GREY



LATTE  
BROWN

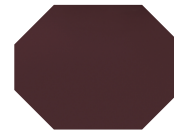

METROPOLITAN



PEWTER



POWDER  
PINK



SELVEDGE  
BLUE



SKY  
BLUE



FRESH  
TEAL

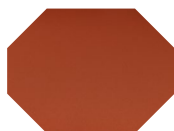

TERRACOTTA



ORIGINAL  
WHITE



DEEP  
YELLOW



---

The Standard - Original 1933™ Design  
Model: CL01

---

## Weight

Due to the handmade nature of the product, weight may vary.  
Approximate weight: 500g.

---

## Handmade Process | Materials

Handmade in England.  
Material: Steel - Finish: Vitreous Enamel.  
Indoor use only.

Steel: infinitely recyclable

---

## Maintenance | Care

Do not use any abrasive cleaning products.  
Vitreous Enamel is smooth and impervious which makes cleaning your lampshade easy.

We recommend you dust your 1933™ Design lampshade with a dry, soft cloth. Stubborn, greasy marks can be removed gently with a soft cloth dampened in lukewarm water with a mild detergent.

Cleaning of the lampshade should only occur when the light is switched off with no power to the circuit. It is important that the electrical fitting is not exposed to any liquids.



## Mounting Indications

The example shows assembly instructions for  
a Coolicon Porcelain Suspension Set - Model: SK01-E14-POR,  
a Coolicon Industrial Suspension Set - Model: SK01-E14-IND  
or a Coolicon Brass Suspension Set - Model: SK01-E14-BRS

For concrete and/or solid substrate ceilings; standard fittings can be used.  
For suspended ceilings; seek specialist advice. Must be able to support a minimum additional weight load of 2.5kg.  
For period properties and/or lath and plaster ceilings; seek specialist advice.

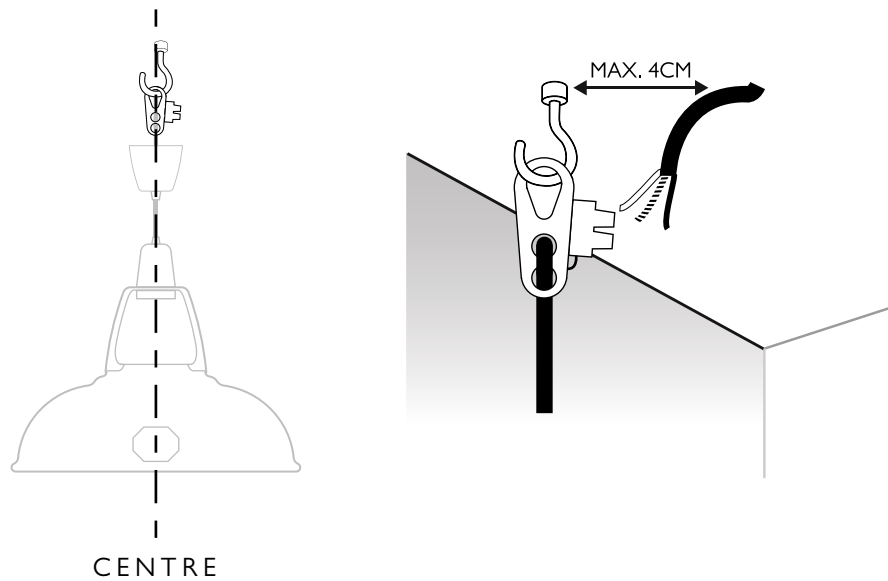

## Conformance & Regulatory

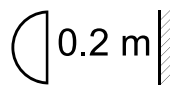

RoHS  
2011/65/EU