

# ARTERIOS

## WAYNE LAMP

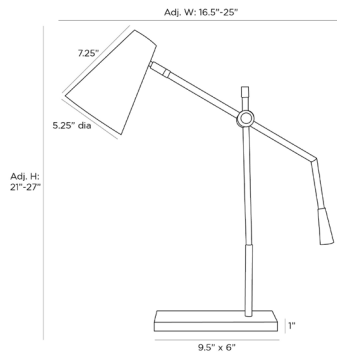

PDC02  
D: 6 IN  
Antique Brass, Steel  
Contract Suitable As Is

Our Wayne suspension task lamp is designed with a conical shade in matte cream enamel and an articulating brass steel arm. The mod illuminator is accented with matching cream enamel, which caps the end of the arm and encircles the lamp's tubular frame at the top and at the base. The shade pivots, casting directional light where you need it.

### APPEARANCE

Material	Steel
Finish	Cream, White
Top Coat/Sealant	true

### DIMENSIONS

Base	5.25
Foot Print	H: 1 IN, W: 9.5 IN, D: 6 IN W: 9.5 IN, D: 6 IN

### WIRING

Rating	Indoor Only
Tilt Test	10 Degrees - AU
Cord	8 FT, Exits Arm, SPT-2, Taupe Fabric
Socket	1, Type A - E26, White
Switch	Full Range Dimmer, On Line
Maximum Watt	40
Voltage	110-120 V

### CERTIFICATIONS

Certifications	Mexico United States, Canada
----------------	---------------------------------

### COMPLIANCY

UL/ETL	Yes
RoHS	true

### SHIPPING

Product Weight	10 LBS
Gross Weight 1	13 LBS
Shipping Box 1	H: 12.4 IN, L: 8.46 IN, W: 32.08 IN

### ADDITIONAL INFO

Shade Shape	Round
Shade Type	Other

### CONTRACT

Contract Suitable	true
-------------------	------