

ARTERIOS

ORLANDO CHANDELIER

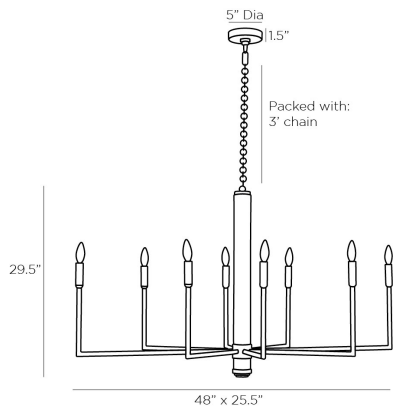

84068
H: 32 IN, W: 48 IN, D: 25.5 IN
Blackened Iron
Contract Suitable As Is

The Orlando finds balance in a traditional shape and industrial materials. The elongated, pseudo linear candelabra silhouette is crafted from blackened iron and is introduced by a natural driftwood column. Fitted with eight lights for incredible brilliance. Finish will vary. Additional chain available (CHN-263). Damp-rated, although limited covered outdoor areas may affect finish.

APPEARANCE

Material	Driftwood, Iron
Finish	Blackened Iron, Natural
Finish Will Vary	true
Top Coat/Sealant	true

DIMENSIONS

Chandelier	H: 29.5 IN, W: 48 IN, D: 25.5 IN
Minimum Hanging Height	32 IN
Maximum Hanging Height	67 IN
Canopy	H: 1.5 IN, Dia: 5.00 IN

WIRING

Rating	Damp
Cert Note	Pending Review
Cord	10 FT, Clear/Silver, SVT
Socket	8, Type B - E12
Photographed Bulb	Clear Straight Tip Candelabra Bulb
Maximum Watt	40
Voltage	110-120 V

COMPLIANCY

RoHS	true
------	------

SHIPPING

Product Weight	20 LBS
Gross Weight 1	42.9 LBS
Shipping Box 1	H: 30.75 IN, L: 51.2 IN, W: 28.35 IN

REPLACEMENT PARTS

Replacement Part 1	CHN-263
Replacement Part 1 Dim	3'
Replacement Part 2	CANOPY-576
Replacement Part 2 Dim	1.5" x 5" Dia

CONTRACT

Contract Suitable	true
-------------------	------