



Attention: Read and understand these instructions before installing fixture. This fixture is intended for installation in accordance with the National Electric Code and local regulation. To assure full compliance with local codes and regulations, check with your local electrical inspector before installation. This equipment is guaranteed only when used as indicated in these instructions; therefore they should be kept for future reference. To prevent electrical shock, turn off power supply before carrying out any connection or maintenance operations. During installation, the LED chips may be exposed; please do not touch them to ensure proper long-term operation.

STEP 1

Make sure you have all the elements of the fixture. Your box should contain the following parts:

Catalogue number :
USC-RDFAK0****08*
USC-RDFAK0****06*

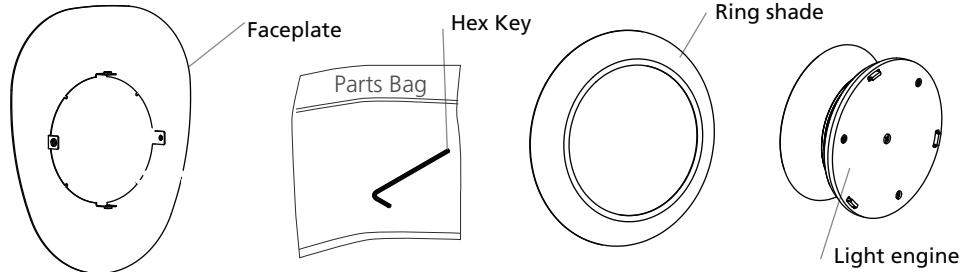

STEP 2

2.1 Remove the middle screw to separate mounting backplate from light engine.

2.1

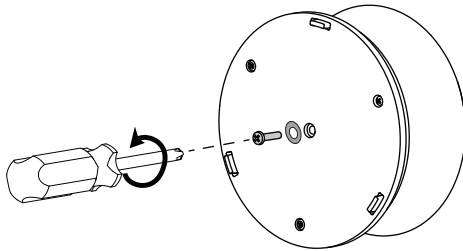

STEP 3

WIRING CONNEXIONS FOR DIMMING OPTION (USC-RDFAxxxx08x or USC-RDFAxxxx06x)

- 3.1 Make appropriate junction box connexions.
- 3.2 Screw the backplate to junction box (screws not included)
- 3.3 Connect the driver to the light engine.

3.1

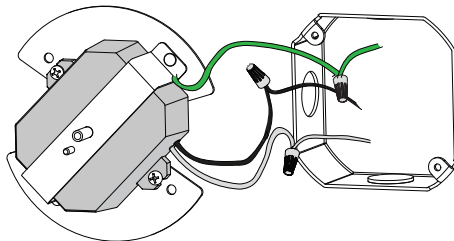

FOR 0-10V DIMMABLE VERSION*		FIXTURE WIRES	CEILING WIRES
PURPLE +	0-10VDC +	GREEN	GREEN
GREY -	DC -	BLACK	BLACK
		WHITE	WHITE

3.2

3.3

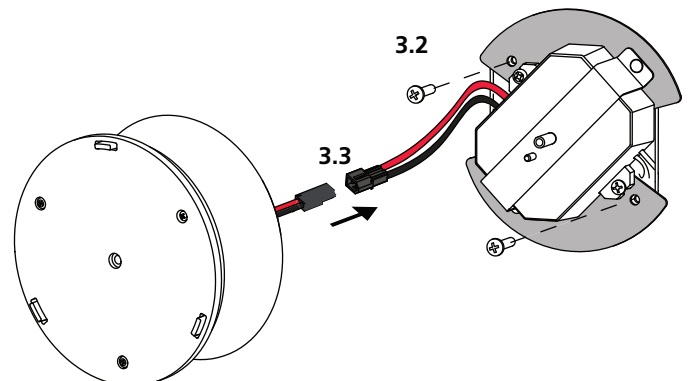

STEP 4

- 4.1 Insert the light engine on the backplate, align center hole with stand-off.
- 4.2 Align the pin on the backplate to the hole in light engine.
- 4.3 Mount the fixture to the backplate and secure it using the screw & washer (removed in STEP 2.1)

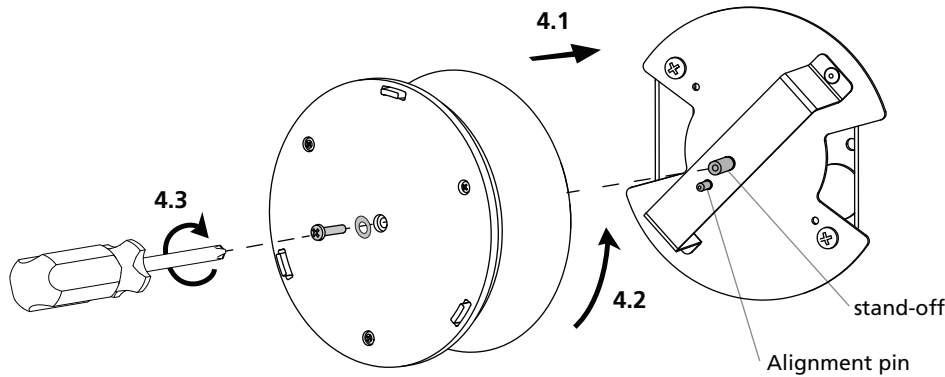

STEP 5

- 5.1 Insert shade on light engine.
- 5.2 Place the face on the light engine.
- 5.3 Hold the face in the diffuser with minimum 2 set-screws provided.

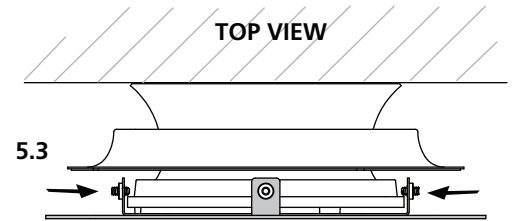
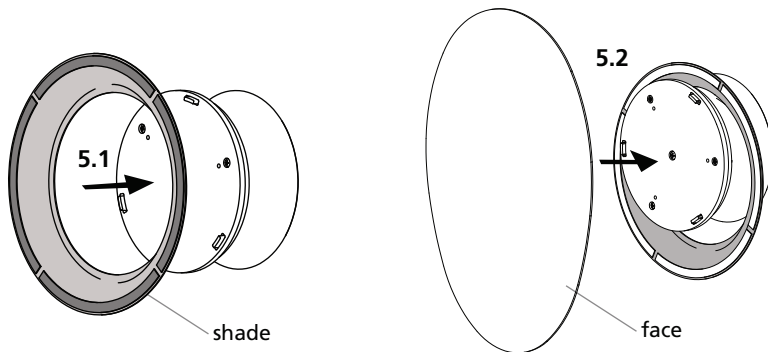

STEP 6

- 6.1 Orient the faceplate.
- 6.2 Secure the face by tightening all the set screws. (not too tight)
- 6.3 Snap the magnetic shade to the back of the faceplate.

