

User Manual

Matters Needing Attention

- **Applicable scenarios**

The Aorkuler Dog GPS Tracker is specifically designed for outdoor use in open environments, such as camping, hiking, and walking with dogs. It operates without relying on cellular networks, making it suitable for areas with limited or no cellular signal coverage. However, it's important to consider the impact of the surrounding environment on GPS and radio communication technologies.

Certain conditions, such as dense buildings, severe weather, thick clouds, high-density forests, and caves, can affect the device's performance by hindering GPS signal reception. To ensure optimal performance, we recommend using the Aorkuler tracker in open outdoor environments.

We prioritize the privacy of our users and, therefore, do not collect any user data. Consequently, we do not provide a dedicated mobile application (APP) for the device. Additionally, please note that the Aorkuler tracker is not suitable for indoor use or for users who require an electronic fence (E-fence) feature.

- **GPS characteristics**

Due to the nature of GPS technology, it may take a little longer for the device to establish satellite connections after being powered off for an extended period or reset. Depending on the environment, the positioning process can take several seconds to three minutes (and may take longer if affected by weather or surrounding conditions). During this time, the controller screen will display "GPS updating." We kindly ask for your patience during this process and recommend using the two devices in open outdoor environments whenever possible.

It's important to note that when any GPS device is stationary, there may be occasional GPS position drift. This means that the direction and distance displayed on the controller may occasionally fluctuate irregularly while both the controller and tracker are stationary. However, once the device starts moving and the tracking function is activated, this situation will be immediately corrected.

- **GPS updating**

When the controller or tracker is in the process of GPS positioning, you will see the message "GPS updating" displayed on the controller screen.

The Aorkuler Dog GPS Tracker is specifically designed to operate without relying on cellular networks for GPS data transmission. This makes it particularly suitable for activities such as camping, hiking, and walking with dogs in open outdoor environments where there is no or poor cellular signal. Instead of using cellular networks for GPS-assisted positioning, Aorkuler devices directly connect to GPS satellites through the built-in GPS chip. As a result, the Aorkuler tracker may take longer to establish

accurate positioning compared to devices that utilize cellular networks for GPS assistance.

To ensure optimal performance during GPS positioning, please follow these guidelines:

1. Use both the controller and tracker in open outdoor environments.
2. It is recommended to securely attach the tracker to your pet's back and keep the front of the tracker facing upward to enhance GPS signal reception.
3. Press the multi-function button on the controller to send a command to the tracker, instructing it to activate the GPS function. This will prevent the tracker from automatically turning off the GPS and entering a power-saving mode if it hasn't received any commands from the controller for an extended period.

● **Battery protection**

To maximize battery life, Aorkuler has implemented a battery protection feature. When the device is used for the first time or has been idle for an extended period, the battery protection may be activated. If you encounter a situation where the device doesn't turn on or doesn't respond when charging, please follow the steps below:

1. Connect the charging cable to the device.
2. Insert a small, pointed object like a paperclip or a pin into the small reset hole on the device to reset the device.

After performing the reset, allow the device to charge for a sufficient amount of time. Please ensure that both the controller and tracker are fully charged before using them. We recommend using an adaptor that meets the necessary safety standards for charging to ensure proper functionality and safety.

● **Real-time tracking**

Aorkuler supports real-time tracking, and it's important to note that during the tracking process, it is normal for the direction and distance displayed to fluctuate or change. This is due to the nature of GPS technology and various environmental factors.

To ensure the accuracy of tracking, please keep the controller in a horizontal position while using it. This will help optimize the reception of GPS signals and improve the overall tracking performance. Additionally, it is recommended to keep moving while tracking to allow the device to continuously update and calculate the position accurately.

● **Optimization of energy saving**

1. If the tracker does not receive any commands from the controller within a 10-minute timeframe, the GPS function of the tracker will automatically turn off. In order to resume tracking, simply press the multi-function button on the controller to turn on the GPS function of the tracker.
2. The Aorkuler tracker and controller have an automatic motion detection feature. If both devices remain in a static state for more than 120 minutes, they will automatically shut down. To resume tracking, simply turn on both devices.

Aorkuler tracker operates differently from other trackers by utilizing a real-time tracking mechanism. This mechanism ensures an excellent tracking experience as the controller and tracker continuously refresh, monitor, calculate, and display position data. The GPS and Radio modules of the Aorkuler Dog GPS Tracker work seamlessly together to provide continuous real-time tracking for approximately 8 hours or

more.

- **The state switching of Nearby/GPS updating/Tracking**

To optimize the working time of the Aorkuler devices, the controller utilizes short-range Bluetooth to scan the surrounding area. When the tracker is in close proximity to the controller, the Bluetooth connection is established, and the controller displays "Nearby" while disabling the tracker's GPS to conserve power.

As the tracker moves away from the controller, the Bluetooth connection between the two devices is disconnected, and the radio and GPS functions of the tracker are automatically activated. The controller will display "GPS updating" as the tracker establishes GPS positioning. Once the positioning is successful, the controller will show the direction and distance of the tracker relative to the controller on the screen.

It is important to note that the effective range of Bluetooth connectivity can be influenced by factors such as weather and the surrounding environment. If the distance between the tracker and the controller is at the critical point of the Bluetooth connection, the display on the controller may toggle between "Nearby," "GPS updating," and "Tracking." However, as the distance between the devices shortens or increases, the working status of the devices will soon stabilize and return to normal.

I. Packing List

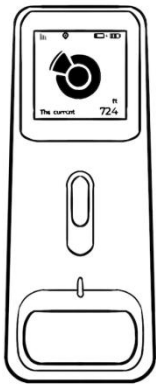

Controller*1

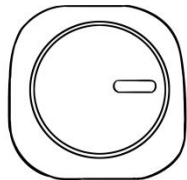

Tracker*1

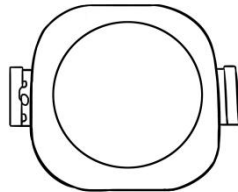

Shell *1

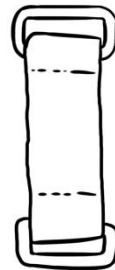

Strap*2

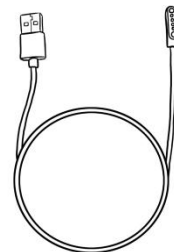

Charging
Cable*2

II. Product Overview

Aorkuler Dog GPS Tracker adopts proprietary positioning algorithm and advanced radio communication technology to transmit the GPS position data of the tracker without relying on the cellular network, and there is no monthly fee or subscription required. In order to protect users' privacy, and considering the usage scenarios of the product in areas with no or poor cellular signals, Aorkuler does not provide APP, but adopts an advanced tracking algorithm to display the direction and distance of the tracker relative to the controller on the screen of the controller in real time. Users can track

conveniently according to the direction indication on the screen of the controller.



Working distance:

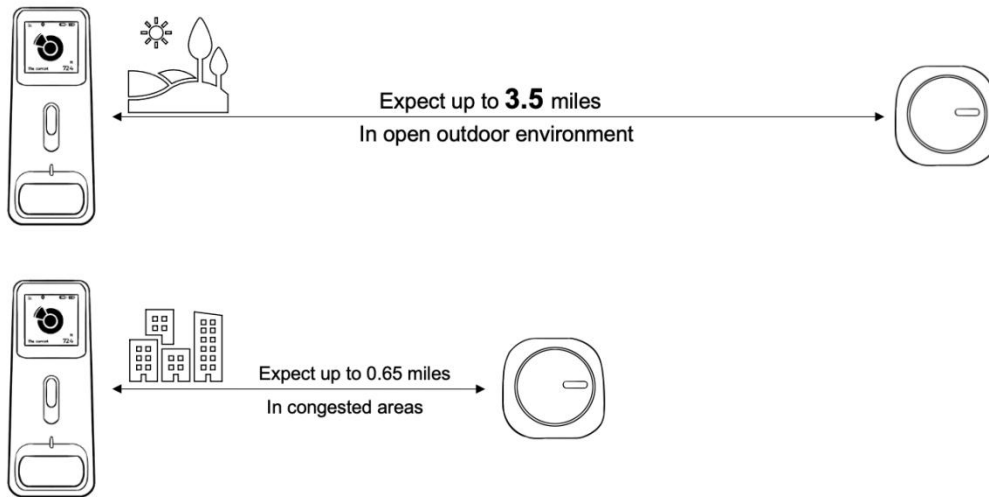

III. How to use

● **Turn on/off the device**

1. Turn on



To turn on the device, simply press and hold the ON/OFF button on the controller or tracker for 3 seconds. Once turned on, the LED indicator will flash three times in a cycle, with colors alternating between red, green, and blue. This confirms that the device is powered on and ready for use.

2. Turn off:

GOODBYE

To turn off the device, press and hold the ON/OFF button on the controller or tracker for 3 seconds while the device is already powered on. During this process, the LED indicator will flash three times, emitting a red light. This indicates that the device is shutting down and will soon be powered off.

- **Calibration of the geomagnetic sensor**



Follow it

To calibrate the geomagnetic sensor of the controller, follow these steps:

1. Hold the device firmly in your hand and wave your arm in the shape of an "8" in the air. Make sure to perform this motion smoothly and steadily.
2. The device will automatically calibrate the geomagnetic sensor during this process.
3. Once the calibration is complete, the device will enter the working mode.

It is recommended to perform this calibration each time you turn on the controller to ensure accurate direction indication. Calibrating the geomagnetic sensor helps the device accurately determine the direction and improves the overall performance of the controller.

- **Working mode**

1. Nearby



Nearby

When the controller detects the Bluetooth signal from the tracker in close proximity and establishes a successful connection, the message "Nearby" will be displayed. This indicates that the controller and tracker are in close range and are communicating through Bluetooth. If the field of view is poor and you're unable to visually locate your dog, you can utilize the sound and light alarm functionality to determine the specific location of your dog.

2. GPS updating



GPS updating

As the tracker moves away from the controller, the Bluetooth connection between the two devices will be automatically disconnected. At this point, the radio and GPS functions will be activated, and the message "GPS updating" will be displayed. This indicates that the devices are in the process of establishing a GPS connection and updating their positions. Once the GPS positioning is successful, the device will enter tracking mode, allowing you to track the location of the tracker.

3. Tracking



The controller's screen will display real-time information about the direction and distance of the tracker relative to the controller. To ensure accurate tracking, please keep the controller horizontal and continue moving while monitoring the screen. This will provide the most reliable tracking information for your convenience.

4. Last position



When the wireless connection between the controller and the tracker is disconnected, the controller will display an offline warning message indicating the last known position of the tracker, followed by the distance in feet. Additionally, the direction indicator will turn red. In such cases, please refer to the direction shown in the illustration and make your way promptly to the location where the connection was lost. This will help you quickly locate and reconnect with the tracker.

● Sound or light alarm



To enable the sound or light alarm function of the tracker, follow these steps:

1. Press and hold the multi-function button on the front of the controller for 3 seconds. This will take you to the selection interface.
2. Use the ON/OFF button to navigate and choose between turning on the sound or light alarm.
3. Once you've made your selection, press the multi-function button again to confirm and activate the chosen function.

When the tracker receives the command from the controller, it will respond accordingly:

1. Sound Alarm: The tracker will emit a sound for 15 seconds.
2. Light Alarm: The tracker's LED light will flash in a cycle of red, green, and blue for 3 minutes.

These alarm features on the Aorkuler Dog GPS Tracker are designed to assist you in quickly locating your dog, especially in poor visibility conditions such as darkness or thick bushes.

Note:

● Keep horizontal



For accurate direction indication, it is recommended to keep the controller in a horizontal position during use. If the elevation angle of the controller becomes too large, the device will display a prompt message saying "keep me horizontal." Keeping the controller horizontal helps ensure optimal performance and reliable direction indication.

● **Tracker installation tips**

Install the tracker on the dog collar/harness. (as shown in the below picture)

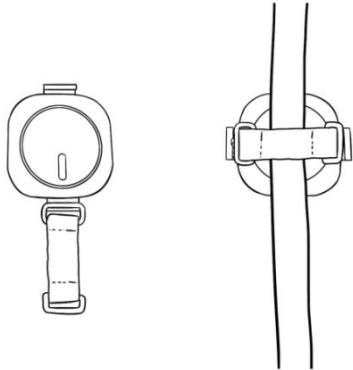

For optimal GPS signal reception, we recommend fixing the tracker on your dog's back and keeping the front of the tracker facing upward. This positioning allows the tracker to better receive GPS signals and provide accurate location tracking.

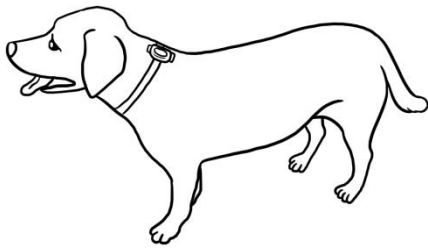

IV. Product Introduction

● Appearance:

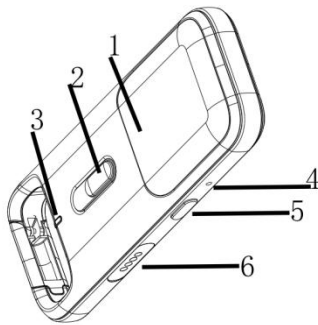

(Controller)

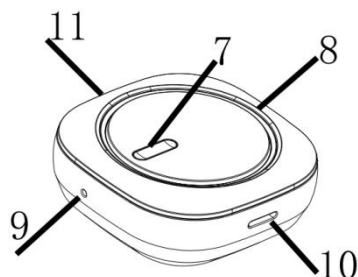

(Tracker)

1. Display screen
2. Multi-function button
3. LED
4. Reset hole
5. ON/OFF button
6. Magnetic charging

7. ON/OFF button
8. LED
9. Reset hole
10. Speaker
11. Magnetic charging

- Definition of buttons







Button functions of the controller







ON/OFF button	Press and hold: turn the device on/off Short press: sleep or wake up
Multi-function button	Press and hold: enter the selection interface for turning on the sound or light alarm of the tracker, select by the ON/OFF button, and then press the multi-function button again to confirm to turn on the corresponding function Short press: wake up the controller screen/wake up the GPS of tracker
Reset hole	Reset the device

Button functions of the tracker









ON/OFF button	Press and hold: turn the device on/off Short press: the red light flashes once
Reset hole	Reset the device

- Icon definition of the controller:

Icon	Function definition
	Hold the device firmly in your hand and wave your arm in the shape of the number 8 (∞) in the air to calibration of the Geomagnetic sensor.
 Nearby	When the Aorkuler controller and tracker are connected via Bluetooth, the word "Nearby" will be displayed on the controller screen. This indicates that the devices are in close proximity to each other and the Bluetooth connection is established.
 GPS updating	The controller and tracker are under the GPS positioning state. For optimal GPS positioning, it is recommended to use both the Aorkuler controller and tracker in an open outdoor environment.
 The current 28.3	Once the GPS positioning of both the Aorkuler controller and tracker is successful, you will see the direction and distance of the tracker relative to the controller displayed on the screen of the controller. This information will help you track and locate your pet accurately.
 Last position 15.9	If the radio connection between the Aorkuler controller and tracker is disconnected or GPS positioning fails, the controller screen will display 'last position * * * ft'. This indicates the direction and approximate distance of the tracker relative to the controller based on the last known position when the two devices were connected. This information can be helpful in determining the general whereabouts of your pet even if the real-time tracking is temporarily unavailable.
 keep me horizontal	If the elevation angle of the Aorkuler device is too large, the device will prompt 'keep me horizontal'. This means that the device should be held or positioned in a horizontal orientation for optimal performance. Holding the device at a large elevation angle may affect its accuracy or functionality, so it is advised to keep it level to ensure reliable operation.

	After pressing and holding the multi-function button of the controller, an icon will appear on the screen. To select the corresponding function, use the ON/OFF button of the controller. Once you have selected the desired function, press the multi-function button again to activate it.
	wireless signal strength
	Electric quantity of controller
	Electric quantity of tracker
	The GPS positioning of the tracker is successful
	Bluetooth connection between controller and tracker succeeded

- LED definition of the device

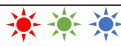
Device	LED	The status of device	LED Definition
Controller/tracker		Charging (in the charging state)	Red light flashing
		Fully charged (in the charging state)	No light flashing
		GPS positioning	The blue light flashes once every second
		GPS positioning successful	The blue light flashes every 5 seconds
		Radio communication connected	Green light flashing
		Turn on the device	Red, green and blue cycle flashing 3 times
		Turn off the device	The red light flashes three times in a row
		The battery is too low to turn on	The red light flashes 6 times in a row
Tracker		Night light function	Red, green and blue light cycle flashing for 3 minutes

V. FAQ

1. What is the Aorkuler dog GPS tracker?

RE: The Aorkuler Dog GPS Tracker consists of a controller and a tracker. Through Aorkuler's proprietary radio communication protocol, the controller establishes a connection with the tracker, allowing it to receive GPS data and send commands. On the controller screen, users can view the direction and distance of the tracker relative to the controller in real time.

Aorkuler Dog GPS Tracker utilizes a proprietary positioning algorithm and advanced radio communication technology to transmit GPS data independently of the cellular network. There are no monthly fees or subscriptions required. To prioritize user privacy and accommodate areas with limited cellular signals, Aorkuler does not offer a dedicated mobile app. Instead, an advanced tracking algorithm is employed to display the tracker's direction and distance on the controller screen, enabling users to conveniently track their pets based on the provided direction indications.

2. Where can Aorkuler's tracker be used? will the weather and environment affect the use of device?

RE: Aorkuler's tracker can be used in various scenarios, including outdoor activities such as camping, hiking, and walking with dogs in open outdoor environments. It is especially suitable for areas with no or poor cellular signals where traditional GPS trackers relying on cellular networks may not function effectively.

The weather and surrounding environment can have an impact on the performance of the device. GPS technology and radio communication technology used by Aorkuler's tracker can be influenced by factors such as dense buildings, thunderstorm weather, thick clouds, high-density forests, caves, and other obstructions. These conditions may hinder the tracker's ability to receive GPS signals.

To ensure optimal performance, it is recommended to use the Aorkuler tracker in open outdoor environments where it has a clear line of sight to GPS satellites. This will help minimize potential interference and maximize the accuracy of tracking.

3. Can I use the Aorkuler dog GPS tracker without a mobile phone?

RE: Yes, you can use the Aorkuler dog GPS tracker without a mobile phone. The Aorkuler tracker consists of a controller and a tracker device. The controller is used to receive GPS data from the tracker and display the direction and distance of the tracker relative to the controller on its screen.

The Aorkuler tracker does not rely on a mobile phone or require an app for its functionality. It utilizes proprietary positioning algorithms and advanced radio communication technology to transmit GPS data without the need for a cellular network or smartphone connectivity. This makes it a standalone tracking solution that can be used independently without the use of a mobile phone.

4. Will Aorkuler consume mobile data?

RE: No, Aorkuler does not consume mobile data. The Aorkuler dog GPS tracker operates independently without relying on a cellular network or mobile data. It utilizes advanced radio communication technology and proprietary positioning algorithms to transmit GPS data between the controller and the tracker. This means that the tracker does not require a SIM card or a data plan, and it will not use any mobile data for its tracking functionality.

5. Will Aorkuler require a monthly fee?

RE: No, Aorkuler does not require a monthly fee. Unlike some GPS tracking devices or services that may involve subscription plans or monthly fees, Aorkuler operates on a one-time purchase basis. Once you purchase the Aorkuler dog GPS tracker, there are no additional monthly fees or subscriptions required to use the device. This allows you to track your dog's location without any recurring costs, providing a cost-effective solution for pet owners.

6. Why do I need to calibrate the geomagnetic sensor each time when the Aorkuler tracker is turned on?

RE: The calibration of the Geomagnetic sensor is necessary to ensure accurate and reliable performance of the Aorkuler tracker. The Geomagnetic sensor is responsible for detecting changes in the Earth's magnetic field, which is used to determine the orientation and direction of the tracker. However, factors such as electromagnetic interference or changes in the surrounding magnetic field can affect the sensor's accuracy.

By calibrating the Geomagnetic sensor each time the Aorkuler tracker is turned on, you are allowing the device to establish a baseline reference for the Earth's magnetic field in its current environment. This helps the tracker accurately interpret the sensor readings and provide more precise directional information.

Calibrating the Geomagnetic sensor by waving the device in the shape of an "8" helps the tracker gather data from different orientations and angles, enabling it to calibrate itself to the local magnetic field. This process enhances the overall performance and reliability of the tracker's directional capabilities. Therefore, it is recommended to perform the calibration process to ensure optimal tracking accuracy.

7. What should I do if the calibration of geomagnetic sensor of Aorkuler tracker fails?

RE: If the calibration of the Geomagnetic sensor for your Aorkuler tracker fails, there are a few steps you can take to troubleshoot the issue:

- Ensure proper device positioning: Make sure you are holding the tracker in a horizontal position and waving it in the shape of an "8" as instructed during the calibration process. Ensure that there are no nearby magnetic or electromagnetic sources that could interfere with the sensor.
- Restart the tracker: Try turning off the Aorkuler tracker and then turning it back on. This can help reset the device and allow for a fresh calibration attempt.
- Remove any magnetic interference: Magnetic or electromagnetic sources near the tracker can affect the calibration process. Keep the tracker away from items such as metal objects, magnets, or electronic devices that could generate magnetic fields.
- Contact customer support: If you have followed these steps and the calibration still fails, it is recommended to reach out to Aorkuler's customer support (Email: service@aorkuler.com) for further assistance. They will be able to provide specific troubleshooting steps or arrange for a replacement if necessary.

Remember that proper calibration of the Geomagnetic sensor is crucial for accurate tracking performance, so it's important to address any calibration issues to ensure optimal functionality of your Aorkuler tracker.

8. Why does the controller sometimes display 'GPS updating' for a long time and can't connect to the tracker?

RE: The controller displaying "GPS updating" for an extended period and being unable to connect to the tracker can occur due to several reasons. Here are some possible explanations:

- Environmental factors: The GPS technology used by Aorkuler relies on receiving signals from satellites. In certain situations, such as being indoors, surrounded by dense buildings, or in areas with poor satellite visibility, it may take longer for the tracker to establish a GPS connection. It's recommended to use the Aorkuler tracker in an open outdoor environment to ensure better GPS signal reception.
- Weather conditions: Adverse weather conditions like heavy rain, thunderstorms, or thick cloud cover can interfere with GPS signals and impact the tracker's ability to establish a connection. In such cases, it is normal for the controller to display "GPS updating" until a stable GPS signal is acquired.
- Obstructions or interference: Objects or structures that obstruct the tracker's line of sight to the GPS satellites can hinder signal reception. Additionally, electromagnetic interference from nearby electronic devices can also affect the tracker's ability to connect to GPS satellites.
- Battery level: If the battery of either the controller or the tracker is low, it may affect the GPS connection. Ensure that both devices have sufficient battery power to maintain a stable connection.

If the controller continues to display "GPS updating" for an extended period and fails to connect to the tracker despite being in an open outdoor environment, it's recommended to perform the following steps:

- Ensure both the controller and tracker are fully charged.
- Restart both devices by turning them off and then back on.
- Verify that there are no obstructions or interference sources around the tracker that could hinder GPS signal reception.
- If the issue persists, it's advisable to contact Aorkuler's customer support for further assistance and troubleshooting.

Remember that GPS signal acquisition can sometimes take longer in challenging conditions, so it's important to be patient and allow the tracker sufficient time to establish a stable GPS connection.

And you can visit the official website of GPS, which clearly explains the working principle of GPS technology in detail. Basically, the official GPS website states that the connection time and accuracy of GPS depend on the number of obstacles between the GPS satellite and the device itself.

<https://www.gps.gov/systems/gps/performance/accuracy/>

- Good GPS accuracy: in open outdoor environment (beach, national park or city square).
- Poor GPS accuracy: in very dense area (impenetrable forest or very crowded urban environment with a lot of obstacles), Cloudy weather, Indoor positioning is not desirable.

9. The device is under 'GPS updating' state continuously. How can I know which device is not positioned successfully?

RE: If the device is continuously displaying "GPS updating" and you want to determine which device

is not positioned successfully, you can try testing each device separately. And judge according to the LED of the device. When the blue light of the device flashes once every second, it indicates that the device is in positioning. When the blue light of the device flashes once every 5 seconds, it means that the device has been positioned successfully. This way, you can identify if one device consistently fails to acquire GPS positioning.

10. Is the direction and distance displayed on the Aorkuler controller accurate?

RE: The direction and distance displayed on the Aorkuler controller provide a relative indication of the tracker's position with respect to the controller. While the displayed information can be helpful for tracking and locating the tracker, it's important to note that the accuracy may be subject to certain limitations.

The accuracy of the direction and distance readings can be affected by various factors, including the surrounding environment, GPS signal quality, magnetic interference, and the position and orientation of the devices. Environmental factors such as dense buildings, thick clouds, high-density forests, or caves may hinder the tracker's ability to receive GPS signals, which can impact the accuracy of the displayed information.

Additionally, the geomagnetic sensor used for determining direction can be influenced by magnetic interference from objects in the environment. This can introduce slight deviations or variations in the displayed direction readings.

It's also worth noting that GPS positioning itself may have inherent inaccuracies, and slight variations or drift in the tracker's position can occur even when stationary. These factors can contribute to small discrepancies between the displayed direction and the actual direction.

While Aorkuler strives to provide accurate and reliable tracking information, it's important to interpret the direction and distance displayed on the controller as approximate values rather than precise measurements. It is recommended to use the displayed information as a general guide to assist in locating the tracker, but to rely on additional cues and common sense to ensure accuracy in real-world scenarios.

If precise and highly accurate positioning is required, it may be beneficial to use other dedicated tracking systems or technologies that provide more precise measurements.

11. Why sometimes my dog doesn't move, but the direction or distance on the controller changes?

RE: The situation where the direction or distance on the controller changes even when your dog is not moving can occur due to several reasons. Here are a few possible explanations:

- **GPS Signal Fluctuations:** The GPS positioning technology used by Aorkuler relies on signals received from satellites. In certain environments, such as areas with obstructed views of the sky or dense buildings, the GPS signals can be prone to fluctuations or multipath interference. These variations can cause slight changes in the reported position, leading to apparent changes in direction or distance even when the dog is stationary.
- **GPS Error and Accuracy:** GPS positioning has inherent errors and accuracy limitations. Even when your dog is not moving, there can be small variations or drift in the reported position due to factors like atmospheric conditions, satellite geometry, and signal reception. These variations can contribute to changes in the displayed direction or distance.
- **Environmental Factors:** Surrounding magnetic fields or magnetic objects in the environment can

impact the accuracy of the geomagnetic sensor used for determining direction. Magnetic interference can cause slight deviations or fluctuations in the displayed direction readings, even if your dog is not moving.

- **Sensor Sensitivity:** The controller may have a certain level of sensitivity or responsiveness in interpreting the sensor data. Small movements or changes in orientation of the controller, even if unintentional or caused by external factors, can be detected and reflected in the displayed direction or distance.

It's important to note that these changes in the displayed information should be interpreted with caution. If you observe significant or consistent discrepancies between the displayed readings and your dog's actual movement or position, it may be worth investigating further or contacting Aorkuler's customer support for assistance.

In general, it's recommended to consider the direction and distance displayed on the controller as an approximate guide and rely on additional cues, such as visual observation or common sense, to accurately assess your dog's movement and location.

12. What should I do when the direction and distance displayed on the Aorkuler controller deviates greatly from the actual?

RE: If you notice a significant deviation between the direction and distance displayed on the Aorkuler controller and the actual position of your dog, here are a few steps you can take to address the issue:

- **Check the Controller Position:** Ensure that you are holding the controller in a horizontal position, as this is the optimal alignment for accurate direction readings. Tilting or angling the controller can introduce errors in the displayed direction. Try to maintain a steady and level position while using the controller.
- **Confirm GPS Signal Strength:** If the signal is weak or unstable, it can lead to inaccuracies in the displayed direction and distance. Move to an open outdoor area away from obstructions to improve GPS signal reception.
- **Calibrate the Geomagnetic Sensor:** If you haven't already done so, perform the calibration process for the geomagnetic sensor as instructed in the user manual. This calibration helps the sensor account for magnetic interference and enhances the accuracy of direction readings. Make sure to follow the calibration steps correctly.
- **Consider Environmental Factors:** Be aware of any potential sources of magnetic interference in your surroundings. Magnetic fields generated by electronic devices, metal objects, or power lines can affect the accuracy of the geomagnetic sensor. Try moving to a different location with fewer magnetic disturbances and re-evaluate the displayed readings.
- **Reset the Devices:** If the discrepancies persist, try resetting both the controller and the tracker. Follow the instructions provided in the user manual for performing a reset. This can help resolve any temporary software glitches or calibration issues that might be affecting the accuracy of the displayed information.
- **Contact Customer Support:** If you have followed the above steps and are still experiencing significant deviations between the displayed readings and the actual position, it may be helpful to reach out to Aorkuler's customer support. They can provide further guidance, troubleshoot the issue, or offer potential solutions based on their expertise.

Remember that the displayed direction and distance on the controller should be considered as an

approximate indication. It's always important to use your judgment, visually observe your dog's movements, and rely on additional cues to ensure their safety and accurate tracking.

13. What is the working distance of Aorkuler dog GPS tracker?

RE: The exact working distance of the Aorkuler Dog GPS Tracker can vary depending on the specific environment and conditions. Here is a general guideline for the working distance in different environments:

- **Open Outdoor Environment:** In an open outdoor environment with minimal obstructions and a clear line of sight between the controller and the tracker, the working distance can reach up to 3.5miles.
- **Urban Environment:** In urban areas with buildings, structures, and other obstacles, the working distance may be reduced. The presence of walls, buildings, and other structures can block or weaken the radio signal, resulting in a shorter working distance. In such environments, the working distance may range from tens meters to 0.65miles, depending on the level of obstruction.

It's important to note that these working distance estimates are general guidelines and can vary based on factors specific to each environment. It's recommended to test the device in your specific surroundings to get a better understanding of the working distance you can expect.

Additionally, Aorkuler Dog GPS Tracker is not recommended to be used in dense forest and indoor environments. These environments can significantly impact the performance and effectiveness of the tracker due to the presence of dense vegetation, trees, and structures that can obstruct the radio signal. In dense forest areas, the signal may be weakened or blocked by the thick foliage, resulting in limited working distance and reduced tracking accuracy. Similarly, indoor environments with walls and structures can impede the signal, making it challenging for the tracker to establish a reliable connection between the controller and the tracker.

For optimal performance, it is recommended to use the Aorkuler tracker in open outdoor environments with a clear line of sight and minimal obstructions.

14. What should I do if my dog exceeds the working distance of the Aorkuler?

RE: When the wireless connection between the controller and the tracker is disconnected, the controller will display an offline warning with the message "last position * * ft" and the direction indicator will turn red. In such a situation, it is important to follow the direction shown on the controller's screen and move towards the last known position of the tracker as quickly as possible.

By moving towards the disconnected position of the tracker, you increase the chances of re-establishing the connection between the controller and the tracker. If the devices still do not reconnect, it is recommended to move to an open area or a higher location nearby. This can help improve the wireless signal strength and facilitate the reconnection between the two devices.

It's crucial to act promptly when the wireless connection is lost to ensure the timely reconnection and tracking of your dog. Following the guidance provided on the controller's screen and seeking a better signal reception area will help enhance the chances of restoring the connection between the Aorkuler controller and tracker.

15. Can the Aorkuler tracker be used indoors?

RE: No, the Aorkuler tracker is not recommended for indoor use. It is designed and optimized for outdoor environments where GPS signals and radio communication can be effectively received. Indoor

environments typically have limited or no GPS signal reception, which can significantly affect the accuracy and functionality of the tracker. Additionally, the Aorkuler tracker relies on its proprietary radio communication technology rather than cellular networks, which may further limit its usability indoors. Therefore, it is best to use the Aorkuler tracker in open outdoor environments to ensure optimal performance and tracking capabilities.

16. What is the warranty policy of the Aorkuler dog GPS tracker?

RE: The warranty period for the Aorkuler dog GPS tracker is 12 months from the date of product receipt, excluding any damage caused by human actions. To further extend the warranty coverage, you have the option to join our extended warranty plan. By enrolling in this plan, you can enjoy an additional 12 months of warranty coverage. For more information on the extended warranty, please refer to the warranty card included in the packaging box of the Aorkuler dog GPS tracker.

17. Why can't Aorkuler's controller or tracker be turned on?

RE: If you are experiencing difficulties in turning on the Aorkuler controller or tracker, please check the following:

- **Battery Level:** Ensure that the device has sufficient battery power. If the battery is low or depleted, connect the device to a power source and allow it to charge for a sufficient amount of time.
- **Battery Protection:** In some cases, the battery protection feature may be activated, especially when the device is being used for the first time or has not been used for an extended period. To resolve this issue, follow these steps to exit the battery protection mode and allow the device to function properly:
 - 1) Connect the charging cable to the device.
 - 2) Insert a small, pointed object like a paperclip or a pin into the small hole to reset the device.
- **Contact Support:** If none of the above steps work, it is recommended to contact Aorkuler's customer support (Email: service@aorkuler.com) for further assistance. They will be able to provide you with specific troubleshooting steps or arrange for a repair or replacement if necessary.

Remember to refer to the user manual or contact customer support for detailed instructions specific to your Aorkuler device model.

18. Why can't Aorkuler's controller or tracker be charged?

RE: If you are experiencing difficulties charging the Aorkuler controller or tracker, there could be several possible reasons:

- **Insufficient power source:** Ensure that you are using a power source that provides adequate power output for charging. Use the provided charging cable and a compatible power adapter.
- **Faulty charging cable or adapter:** Check the charging cable and adapter for any signs of damage. Try using a different cable and adapter to see if the issue persists.
- **Connection issues:** Make sure that the charging cable is securely connected to both the controller or tracker and the power source. Clean the charging ports on the device and ensure there is no debris or dirt obstructing the connection.
- **Battery protection:** The device may have activated its battery protection feature, especially if it is being used for the first time or has not been used for a long time. In this case, connect the charging cable and insert a small, pointed object like a paperclip or a pin into the small reset hole to reset the device to deactivate the battery protection.

If you have tried these steps and the controller or tracker still cannot be charged, it is recommended to contact Aorkuler customer support(Email: service@aorkuler.com) for further assistance or consider getting the device inspected or replaced if it is still under warranty.

19. How long can the battery of the Aorkuler tracker last?

RE: The battery life of the Aorkuler tracker can vary depending on various factors such as usage patterns, tracking frequency, and environmental conditions. Generally, the Aorkuler tracker supports continuous real-time tracking for 8 hours or more on a fully charged battery.

It's important to note that enabling certain features like sound or light alarms may consume more battery power and can impact the overall battery life. Additionally, factors such as the strength of the GPS signal, temperature, and battery health can also affect battery performance.

To maximize the battery life of the Aorkuler tracker, it is recommended to fully charge the device before use, optimize usage by turning off unnecessary features when not needed, and charge the tracker regularly to ensure it has sufficient power for tracking sessions.

In the same weather and environment, Aorkuler's engineers tested Aorkuler trackers, GPS watches and smart phones with GPS navigation and positioning turned on, and the actual situation is as follows:

- 1) Under the condition of continuous tracking, the Aorkuler Dog GPS Tracker can operate for a minimum of 8 hours. This duration is based on the uninterrupted operation of the GPS chip, which is responsible for accurate positioning and location updates.
- 2) Smart watch can work for about 3 hours when GPS positioning is refreshed continuously.
- 3) Smart phones can work for about 4 hours when GPS navigation is in the state of continuous operation.

20. Why is the device turned off automatically sometimes?

RE: The Aorkuler device is designed to conserve battery power and optimize its performance. It may automatically turn off in certain situations to preserve battery life and ensure efficient operation. Here are a few common reasons why the device may turn off automatically:

- Inactivity: If there is no user interaction or commands received by the device for more than 120 minutes, it may enter a power-saving mode and turn off to save energy.
- Low Battery: When the battery level of the device is critically low, it may automatically shut down to prevent complete battery drain, which can potentially damage the battery.

If the device turns off automatically, you can typically turn it back on by pressing and holding the power button for a few seconds until it powers up. It's important to ensure that the device is adequately charged to prevent frequent automatic shutdowns due to low battery levels.

21. Why is the GPS of the tracker turned off automatically sometimes?

RE: To save power, if the tracker doesn't receive any commands from the controller for 10 minutes, the GPS function will be automatically turned off. In this case, the controller will display the last position of the tracker before the GPS was turned off. If you want to track again, you can press the multi-function button on the controller to turn on the GPS of the tracker, and it will resume providing real-time tracking information. This feature helps to conserve battery life and ensures that the GPS is only active when needed.

22. Shall I need to turn off the Aorkuler tracker when I don't need to track my dog?

RE: In order to optimize power usage, the Aorkuler tracker has a feature where if it doesn't receive any commands from the controller within 10 minutes, the GPS function will be automatically turned off. To track again, you can simply press the multi-function button on the controller to turn on the GPS of the tracker.

Additionally, both the controller and the tracker have motion detection capabilities. If they detect that they have been in a static state for more than 120 minutes, they will automatically shut down to conserve power. If you want to use the devices again, you can turn them on by pressing the power button.

If you don't need to use the Aorkuler tracker for a long period of time, you can turn off both the controller and the tracker by pressing and holding the ON/OFF button of each device. This helps to preserve battery life when the devices are not in use.

23. Is the Aorkuler dog GPS tracker waterproof?

RE: The Aorkuler tracker has a higher IP67 waterproof rating. This means it offers a higher level of protection against water immersion. With an IP67 rating, the tracker is capable of withstanding being submerged in water up to a certain depth for a limited time. While it is suitable for swimming or snorkeling in emergencies, it is not designed for prolonged or deep-water activities.

On the other hand, The Aorkuler controller is designed with IP65 waterproof rating, which means it is protected against water splashes from any direction and is also resistant to dust. This allows you to use the controller confidently in rainy conditions, snowy weather, or even during storms, as it can withstand water splashing without getting damaged.

It's important to note that although both devices have waterproof capabilities, they should not be fully submerged or subjected to prolonged water exposure beyond their specified ratings to ensure their optimal performance and longevity.

Please visit the website <https://Aorkuler.com/pages/faqs> for more detailed information about the usage of the device.

For any after-sales questions or inquiries, please contact service@aorkuler.com for assistance.