



Service Manual

**Valleylab Force EZ™-C Series
Electrosurgical Generator**

with Instant Response™ Technology

Preface

This manual and the equipment it describes are for use only by qualified medical professionals trained in the particular technique and surgical procedure to be performed. It is intended as a guide for servicing the Valleylab Force EZ™-C Series Electrosurgical Generator only.

Caution

Federal (USA) law restricts this device to sale by or on the order of a physician.

Equipment covered in this manual:

Force EZ™-C Series Electrosurgical Generator with Instant Response™ Technology
100–120 V ~ (110 V ~ nominal), 220–240 V ~ (230 V ~ nominal) –
(user selectable)

The *Service Manual, Force EZ™-C Series Electrosurgical Generator with Instant Response™ Technology*, consists of two parts—the text (part 1 of 2) and a Schematics Supplement (part 2 of 2), which contains the schematics.

Valleylab Part Number: 1015435 (part 1 of 2)

Effective Date: November 2008

Trademark acknowledgements:

Force FX™, Force EZ™, Force Argon™, Force GSU™, SurgiStat™, REM™, EDGE™, AccuVac™, PolyHesive™, and Instant Response™ are trademarks of Valleylab.

Patent Information:

Protected by U.S. Pat. Nos. 5,599,344; and 5,628,745.

Manufactured by



Valleylab
a division of Tyco Healthcare Group LP
Boulder, Colorado 80301-3299 USA



European Representative:

Tyco Healthcare UK Ltd.
Gosport, PO13 0AS, UK

For information call:

1-303-530-2300



Made in USA
Printed in USA
©2008 Valleylab All rights reserved.

Conventions Used in this Guide

Warning

Indicates a potentially hazardous situation which, if not avoided, could result in death or serious injury.

Caution

Indicates a hazardous situation which, if not avoided, may result in minor or moderate injury.

► Important

Indicates an operating tip or maintenance suggestion.

Notice

Indicates a hazard which may result in product damage.

Warranty

Valleylab, a division of Tyco Healthcare Group LP, warrants each product manufactured by it to be free from defects in material and workmanship under normal use and service for the period(s) set forth below. Valleylab's obligation under this warranty is limited to the repair or replacement, at its sole option, of any product, or part thereof, which has been returned to it or its Distributor within the applicable time period shown below after delivery of the product to the original purchaser, and which examination discloses, to Valleylab's satisfaction, that the product is defective. This warranty does not apply to any product, or part thereof, which has been repaired or altered outside Valleylab's factory in a way so as, in Valleylab's judgment, to affect its stability or reliability, or which has been subjected to misuse, neglect, or accident.

The warranty periods for Valleylab products are as follows:

ForceTriad™ Energy Platform	One year from date of shipment
Electrosurgical Generators	One year from date of shipment
RFG-3C™ Plus Lesion Generator	One year from date of shipment
LigaSure™ Vessel Sealing System	One year from date of shipment
LigaSure™ Reusable Instruments	One year from date of shipment
Mounting Fixtures (all models)	One year from date of shipment
Footswitches (all models)	One year from date of shipment
Force Argon™ Units	One year from date of shipment
OptiMumm™ Smoke Evacuator	Two years from date of shipment
LigaSure™ Sterile Single Use Items	Sterility only as stated on packaging
Sterile Single Use Items	Sterility only as stated on packaging
Patient Return Electrodes	Shelf life only as stated on packaging

This warranty is in lieu of all other warranties, express or implied, including without limitation, the warranties of merchantability and fitness for a particular purpose, and of all other obligations or liabilities on the part of Valleylab. Valleylab neither assumes nor authorizes any other person to assume for it any other liability in connection with the sale or use of any of Valleylab's products.

Notwithstanding any other provision herein or in any other document or communication, Valleylab's liability with respect to this agreement and products sold hereunder shall be limited to the aggregate purchase price for the goods sold by Valleylab to the customer. There are no warranties which extend beyond the terms hereof. Valleylab disclaims any liability hereunder or elsewhere in connection with the sale of this product, for indirect or consequential damages.

This warranty and the rights and obligations hereunder shall be construed under and governed by the laws of the State of Colorado, USA. The sole forum for resolving disputes arising under or relating in any way to this warranty is the District Court of the County of Boulder, State of Colorado, USA.

Valleylab, its dealers, and representatives reserve the right to make changes in equipment built and/or sold by them at any time without incurring any obligation to make the same or similar changes on equipment previously built and/or sold by them.



Table of Contents

Preface	ii
Conventions Used in this Guide	iii
Warranty	iv
List of Figures	xiii

Section 1. Service Personnel Safety

Safety Information	1-2
Warnings, Cautions, and Notices	1-2
General	1-2
Fire/Explosion Hazards	1-3
Electric Shock Hazards	1-4
Servicing	1-4
Calibration	1-5
Cleaning	1-5

Section 2. Introduction

General Description	2-2
List of Components	2-2
Instant Response Technology	2-3
Bipolar Modes	2-3
Monopolar Cut and Coag Modes	2-3
Cut Modes	2-3
Coag Modes	2-4
REM Contact Quality Monitoring System	2-4
How the REM System Works	2-5
Electrodes Without the REM Safety Feature	2-5
Special Features	2-5
Low (Desiccate) Coag Settings	2-5
High (Fulgurate) Coag Settings	2-6
Recall of Most Recently Used Modes and Power Settings	2-6
Default Coag Mode	2-6
Original Default Settings	2-6

Section 3. Controls, Indicators, and Receptacles

Front Panel	3-2
Rear Panel	3-6
Option Panel	3-8

Section 4. Technical Specifications

Performance Characteristics	4-2
General	4-2

Dimensions and Weight	4-2
Operating Parameters	4-2
Transport and Storage	4-3
Duty Cycle	4-3
Internal Memory	4-3
Audio Volume	4-4
REM Contact Quality Monitor	4-4
Serial Port	4-5
RF Activation Port	4-5
Input Power	4-6
Low Frequency (50-60 Hz) Leakage Current	4-7
High Frequency (RF) Leakage Current	4-7
Standards and IEC Classifications	4-8
Class I Equipment (IEC 60601-1)	4-8
Liquid Spillage (IEC 60601-2-2 Clause 44.3)	4-9
Electromagnetic Interference	4-9
Electromagnetic Compatibility (IEC 60601-1-2 and IEC 60601-2-2)	4-9
Voltage Transients (Emergency Generator Mains Transfer)	4-9
Output Characteristics	4-14
Available Power Settings in Watts	4-14
Maximum Output for Force EZ-C Series Electrosurgical Generator Modes	4-15
Output Waveforms	4-16
Output Power vs. Resistance Graphs	4-17

Section 5. Principles of Operation

Functional Overview	5-3
Instant Response Technology	5-3
REM Contact Quality Monitoring System	5-3
Control Board	5-4
Microcontrollers	5-5
Main Microcontroller	5-5
Feedback Microcontroller	5-6
Shared RAM	5-7
Real-Time Clock	5-7
I/O Expansion	5-7
Keyboard Interface and Activation Inputs	5-7
Power Supply Supervisor Circuit	5-8
A/D and D/A Conversion	5-8
Waveform Generation (T_ON ASIC)	5-8
T_ON Average Check	5-9
Audio Alarm	5-9
Serial Interface	5-9
Dosage Error Algorithm	5-10

Instant Response Algorithm	5-11
Display Board	5-12
Bipolar, Cut, and Coag Power Setting Encoders	5-12
RF Indicator Lamps	5-13
LED and Seven-Segment Display Drivers	5-13
Mode Selection Switches	5-14
REM Switch Circuit	5-15
Front Panel Footswitch Circuit	5-15
Footswitch Board	5-16
Power Supply/RF Board	5-16
Power Supply/RF Board Interfaces	5-17
High Voltage Power Supply	5-17
Low Voltage Power Supply	5-20
RF Output Stage	5-21
Spark Control Circuit	5-24
RF Leakage Sensing and Reduction Circuit	5-25
REM Circuit	5-25
IsoBloc Circuit	5-25
Audio Circuit	5-26
Footswitch Decode Circuit	5-28
Temperature Sense Circuit	5-28

Section 6. Setup, Tests, and Adjustments

Setting Up the Generator	6-2
Connections for Bipolar Surgery	6-4
Setting the Bipolar Output	6-5
Connections for Monopolar Surgery	6-5
Set the Cut and Coag Output	6-7
Using Two Generators Simultaneously	6-8
Setting Up the Special Features	6-8
Changing the Mode	6-10
Changing the Power Setting	6-10
Activating the Surgical Instrument	6-11
Periodic Safety Check	6-12
Recommended Test Equipment	6-12
Inspecting the Generator and Accessories	6-13
Inspecting the Internal Components	6-14
Testing the Generator	6-15
Verifying REM Function	6-16
Confirming Outputs	6-16
Checking the Monopolar Output	6-18
Checking Low Frequency Leakage Current and Ground Resistance	6-20

Checking High Frequency Leakage Current and Ground Resistance	6-21
Calibrating the Force EZ-C Series Electrosurgical Generator	6-22
Preparing for Calibration	6-24
Entering Calibration Mode	6-24
Exiting Calibration Mode	6-25
Calibration Step 1 – Verify the Force EZ-C Series Electrosurgical Generator Data	6-25
Calibration Step 2 – Adjust the Calendar	6-26
Calibration Step 3 – Adjust the Clock	6-27
Calibration Step 4 – Check the REM Impedance	6-28
Calibration Step 5 – Check and Adjust the Current Sense Gain	6-29
Calibration Step 6 – Check and Adjust the Voltage Sense Gain	6-31
Calibration Step 7 – Check and Adjust the Reactance Gain	6-33
Calibration Step 8 – Check and Adjust the ECON Factor	6-35

Section 7. Troubleshooting

Inspecting the Generator	7-2
Correcting Malfunctions	7-3
Responding to System Alarms	7-11
Correcting Integrated Circuit (IC) Malfunctions	7-22
Correcting T_ON ASIC Malfunctions	7-22
Correcting Battery-Backed RAM Malfunctions	7-24

Section 8. Replacement Procedures

Interconnect Diagram	8-2
Battery	8-3
Equipment	8-3
Procedure	8-3
Control Board	8-4
Equipment	8-4
Procedure	8-4
Display Board	8-5
Equipment	8-5
Remove the Display Board	8-5
Install the Display Board	8-6
Display Board Seven-Segment LED	8-7
Footswitch Board Assembly	8-7
Equipment	8-7
Front Panel	8-8
Equipment	8-8
Remove the Front Panel Assembly	8-8
Remove and Reinstall the Front Panel Components	8-9
Install the Front Panel Assembly	8-10

Front Panel Footswitch Receptacle	8-10
Front Panel Knob	8-11
Equipment	8-11
Procedure	8-11
Front Panel Power Switch	8-12
Front Panel REM Lever	8-13
Fuses	8-13
Replacing Fuses in the Fuse Drawer	8-13
Replacing the Fuse on the Low Voltage Power Supply	8-14
Replacing the Fuse on the Power Supply/RF Board	8-15
Handle	8-16
Left Front Heat Sink Component	8-17
Equipment	8-17
Remove the Left Front Heat Sink	8-17
Replace the Left Front Heat Sink Components	8-18
Install the Left Front Heat Sink	8-18
Left Rear Heat Sink Component	8-19
Equipment	8-19
Remove the Left Rear Heat Sink	8-19
Replace the Left Rear Heat Sink Components	8-20
Install the Left Rear Heat Sink	8-21
Right Heat Sink Component	8-21
Equipment	8-21
Remove the Right Heat Sink	8-21
Replace the Right Heat Sink Components	8-22
Install the Right Heat Sink	8-23
Low Voltage Power Supply	8-24
Equipment	8-24
Remove the Low Voltage Power Supply	8-24
Install the Low Voltage Power Supply	8-25
Power Entry Module	8-26
Equipment	8-26
Remove the Power Entry Module	8-26
Install the Power Entry Module	8-27
Power Supply/RF Board	8-28
Equipment	8-28
Remove the Power Supply/RF Board and Heat Sinks	8-28
Install the Power Supply/RF Board and Heat Sinks	8-29

Section 9. Repair Policy and Procedures

Responsibility of the Manufacturer	9-2
Returning the Generator for Service	9-2

Returning Circuit Boards	9-3
Service Centers	9-4

Section 10. Service Parts

Ordering Replacement Parts	10-2
Force EZ-C Series Electrosurgical Generator Assembly	10-3
Generator Assembly Parts List	10-5
Control Board Components	10-7
Footswitch Board Components	10-8
Power Supply/RF Board Components	10-9

List of Figures

- Figure 3-1. The front panel **3-2**
- Figure 3-2. The front panel - continued **3-4**
- Figure 3-3. Controls and receptacles on the rear panel **3-6**
- Figure 3-4. The option panel on the generator rear panel with the plate removed to show the serial and RF activation ports **3-8**
- Figure 4-1. Standard Bipolar mode — load resistance vs. output power **4-17**
- Figure 4-2. *Pure* mode — load resistance vs. output power **4-18**
- Figure 4-3. *Blend* mode — load resistance vs. output power **4-18**
- Figure 4-4. *Low 1 (Desiccate)* mode — load resistance vs. output power **4-19**
- Figure 4-5. *Low 2 (Desiccate)* mode — load resistance vs. output power **4-19**
- Figure 4-6. *Low 3 (Desiccate)* mode — load resistance vs. output power **4-20**
- Figure 4-7. *High 1 (Fulgurate)* mode — load resistance vs. output power **4-20**
- Figure 4-8. *High 2 (Fulgurate)* mode — load resistance vs. output power **4-21**
- Figure 4-9. *Standard Bipolar mode @ 100 ohms* — generator setting vs. output power **4-22**
- Figure 4-10. *Standard Bipolar mode* — peak voltage vs. output power **4-22**
- Figure 4-11. *Pure mode @ 300 ohms* — generator setting vs. output power **4-23**
- Figure 4-12. *Pure mode* — peak voltage vs. output power **4-23**
- Figure 4-13. *Blend mode @ 300 ohms* — generator setting vs. output power **4-24**
- Figure 4-14. *Blend mode* — peak voltage vs. output power **4-24**
- Figure 4-15. *Low 1 (Desiccate) mode @ 500 ohms* — generator setting vs. output power **4-25**
- Figure 4-16. *Low 1 (Desiccate) mode* — peak voltage vs. output power **4-25**
- Figure 4-17. *Low 2 (Desiccate) mode @ 300 ohms* — generator setting vs. output power **4-26**
- Figure 4-18. *Low 2 (Desiccate) mode* — peak voltage vs. output power **4-26**
- Figure 4-19. *Low 3 (Desiccate) mode @ 300 ohms* — generator setting vs. output power **4-27**
- Figure 4-20. *Low 3 (Desiccate) mode* — peak voltage vs. output power **4-27**
- Figure 4-21. *High 1 (Fulgurate) mode @ 500 ohms* — generator setting vs. output power **4-28**
- Figure 4-22. *High 1 (Fulgurate) mode* — peak voltage vs. output power **4-28**
- Figure 4-23. *High 2 (Fulgurate) mode @ 500 ohms* — generator setting vs. output power **4-29**
- Figure 4-24. *High 2 (Fulgurate) mode* — peak voltage vs. output power **4-29**
- Figure 5-1. A block diagram of the Force EZ-C Series generator **5-2**
- Figure 6-1. Bipolar connections (footswitch activation from the Bipolar Footswitch receptacle on the rear panel) **6-4**
- Figure 6-2. Bipolar connections (footswitch activation from the Footswitch receptacle on the front panel) **6-4**
- Figure 6-3. Bipolar connection (handswitching instrument) **6-5**
- Figure 6-4. Monopolar connections (handswitching instrument) **6-6**
- Figure 6-5. Monopolar connections (footswitch activation from the Monopolar Footswitch receptacle on the rear panel) **6-6**
- Figure 6-6. Monopolar connections (footswitch activation from the Footswitch receptacle on the front panel) **6-7**
- Figure 6-7. The leakage current test circuit **6-20**
- Figure 8-1. Electric cable connections **8-2**
- Figure 8-2. Power switch and cable connections **8-12**

-
- Figure 8-3. Left front heat sink components **8-18**
- Figure 8-4. Left rear heat sink components **8-20**
- Figure 8-5. Right heat sink components **8-22**
- Figure 8-6. Connections to the low voltage power supply **8-25**
- Figure 8-7. Cable connections to the power entry module **8-27**
- Figure 10-1. Exploded view of Force EZ-C Series Electrosurgical Generator parts **10-3**
- Figure 10-2. Top view of Force EZ-C Series Electrosurgical Generator parts, after assembly **10-4**

Service Personnel Safety

Valleylab stresses safety in the use and servicing of its electrosurgical equipment. This section presents the following:

- Safety information
- Warnings, Cautions, and Notices

Refer to the Preface, *Conventions*, for further information on Warnings, Cautions, and Notices.

Safety Information

The safe and effective servicing of electrosurgical equipment depends to a large degree on factors solely under the control of the service person. There is no substitute for a properly trained and vigilant service staff.

Warnings, Cautions, and Notices

Before servicing the generator, it is important that you read, understand, and follow the instructions supplied with it and with any other equipment used to install, test, adjust, or repair the generator.

General

Warning

Patient Safety – Use the generator only if it has completed the self-test as described. Otherwise, inaccurate power outputs may result.

The instrument receptacles on this generator are designed to accept only one instrument at a time. Do not attempt to connect more than one instrument at a time into a given receptacle. Doing so will cause simultaneous activation of the instruments.

Caution

Do not stack equipment on top of the generator or place the generator on top of electrical equipment (except a Force Argon Unit). These configurations are unstable and/or do not allow adequate cooling.

Provide as much distance as possible between the electrosurgical generator and other electronic equipment (such as monitors). An activated electrosurgical generator may cause interference with them.

Do not turn the activation tone down to an inaudible level. The activation tone alerts the surgical team when an accessory is active.

Notice

If required by local codes, connect the generator to the hospital equalization connector with an equipotential cable.

To avoid product damage, connect the power cord to a wall receptacle having the correct voltage.

Active Accessories**Caution**

Connect accessories to the proper receptacle type. In particular, connect bipolar accessories to the Bipolar Instrument receptacle only. Improper connection may result in inadvertent generator activation or a REM Contact Quality Monitor alarm.

Patient Return Electrodes**Warning**

Using a patient return electrode without the REM safety feature will not activate the Valleylab REM Contact Quality Monitoring System.

Fire/Explosion Hazards**Warning**

Danger: *Explosion Hazard* – Do not install the generator in the presence of flammable anesthetics, gases, liquids, or objects.

Fire Hazard – Do not place active accessories near or in contact with flammable materials (such as gauze or surgical drapes). Electrosurgical accessories that are activated or hot from use can cause a fire. Use a holster to hold electrosurgical accessories safely away from patients, surgical team, and flammable materials.

Fire Hazard – Do not use extension cords.

Fire Hazard – For continued protection against fire hazard, replace fuses only with fuses of the same type and rating as the original fuse.

Electric Shock Hazards

Warning

Connect the generator power cord to a properly grounded receptacle. Do not use power plug adapters.

Do not connect a wet power cord to the generator or to the wall receptacle.

To allow stored energy to dissipate after power is disconnected, wait at least five minutes before replacing parts.

Always turn off and unplug the generator before cleaning.

Do not touch any exposed wiring or conductive surfaces while the generator is disassembled and energized. Never wear a grounding strap when working on an energized generator.

When taking measurements or troubleshooting the generator, take appropriate precautions, such as using isolated tools and equipment, using the "one hand rule," etc.

Potentially lethal AC and DC voltages are present in the AC line circuitry, high voltage DC circuitry, and associated mounting and heat sink hardware described in this manual. They are not isolated from the AC line. Take appropriate precautions when testing and troubleshooting this area of the generator.

High frequency, high voltage signals that can cause severe burns are present in the RF output stage and in the associated mounting and heat sink hardware described in this manual. Take appropriate precautions when testing and troubleshooting this area of the generator.

Servicing

Caution

Read all warnings, cautions, and instructions provided with this generator before servicing.

The generator contains electrostatic-sensitive components. When repairing the generator, work at a static-control workstation. Wear a grounding strap when handling electrostatic-sensitive components, **except** when working on an energized generator. Handle circuit boards by their nonconductive edges. Use an antistatic container for transport of electrostatic-sensitive components and circuit boards.

Notice

After installing a new low voltage power supply, verify that the voltages are correct.

Calibration

Caution

To avoid inadvertent coupling and/or shunting of RF currents around the resistor elements, keep the resistors at least 10.2 cm (4 in.) away from any metal surface including tabletops and other resistors. This is especially true if several resistors are connected in series or parallel to obtain a specified value. Do not allow the resistor bodies to touch each other.

Notice

After completing any calibration step, proceed to the next step to save the values from the completed calibration step.

Do not activate the generator with any load resistor higher than 10 ohms while calibrating the current sense gain. Otherwise, product damage will result.

Do not activate the generator with any load resistor lower than 750 ohms while calibrating the voltage sense gain for bipolar output. Otherwise, product damage will result.

Do not activate the generator with any load resistor lower than 3000 ohms while calibrating the voltage sense gain for the pure cut mode. Otherwise, product damage will result.

Do not activate the generator with any load resistor lower than 2000 ohms while calibrating the voltage sense gain for the blend mode. Otherwise, product damage will result.

After calibration, the generator will be ready to use only after you initiate the internal self-test by turning the generator off, then on.

Calibrate the generator after you install a new battery. All data stored in internal memory, including calibration constants, is lost when the battery is replaced.

Calibrate the generator after you install a new Control board. Otherwise it uses default calibration values.

Calibrate the generator after you install a new heat sink or replace components on the heat sink. Component differences may affect output waveforms.

Calibrate the generator after you install a new Power Supply/RF board. Component differences may affect output waveforms.

Cleaning

Notice

Do not clean the generator with abrasive cleaning or disinfectant compounds, solvents, or other materials that could scratch the panels or damage the generator.



Introduction

This manual provides instructions for servicing the Valleylab Force EZ-C Series Electrosurgical Generator. This section introduces the features and components of the generator.

Additional information about using the generator is available in the Force EZ-C Series Electrosurgical Generator with Instant Response Technology User's Guide.

General Description

The Valleylab Force EZ-C Series Electrosurgical Generator is an isolated output electrosurgical generator that provides the power for cutting, desiccating, and fulgurating tissue during electrosurgery. The generator is specifically designed for use in bipolar or monopolar electrosurgery.

It includes the following features:

- Instant Response Technology
- Standard bipolar mode
- Two monopolar cut modes: pure and blend
- Two monopolar coag modes: low (desiccate) and high (fulgurate)
- The Valleylab REM Contact Quality Monitoring System, which protects patients against burns at the patient return electrode site
- User selectable coag settings
- User selectable default settings
- Adjustable activation tone volume
- Force GSU and Force Argon system compatibility

List of Components

The Valleylab Force EZ-C Series Electrosurgical Generator is a self-contained unit. It consists of a main enclosure (cover and base) and power cord. It includes the following components:

- Front panel – the power switch; controls for setting the modes and output power; a footswitch receptacle and button for selecting bipolar or accessory output; receptacles for connecting electrosurgical accessories, and indicators that alert you to the selected modes and the patient return electrode status.
- Rear panel – the power entry module, volume control, two footswitch receptacles, equipotential grounding lug, and option panel.
- Internal components – include the Control (microcontroller) board, Display board, Footswitch board, Power Supply/Radio Frequency (RF) board, low voltage power supply, and heat sinks.

A handle is located on the underside of the chassis.

For details about the interaction of the main components and circuit board descriptions, refer to Section 5, *Principles of Operation*.

Instant Response Technology

The Force EZ-C Series Electrosurgical Generator automatically senses resistance and adjusts the current and output voltage to maintain a consistent effect across different tissue density. This adjustment is based on the selected mode, the power setting, and the level of tissue resistance. As tissue resistance increases, the generator outputs constant current followed by constant power followed by constant voltage. The system controls maximum output voltage to reduce capacitive coupling and video interference and to minimize sparking. This technology applies to the bipolar mode, the cut modes, and the low 2 and low 3 coag settings. It does not apply to the low 1, high 1, and high 2 coag settings.

Bipolar Modes

The Force EZ-C Series Electrosurgical Generator provides a standard bipolar mode usable for most bipolar applications.

Delicate tissue requires less heat to desiccate quickly. The generator provides low voltage, continuous current for faster desiccation without sparking.

The possibility of sparking increases as desiccated tissue dries and becomes more resistant. The generator protects against sparking by limiting the bipolar voltage at relatively high levels of tissue resistance.

For details about the bipolar output characteristics, refer to Section 4, *Technical Specifications*.

Monopolar Cut and Coag Modes

Cut Modes

Two cut modes – pure and blend – allow a wide range of power settings to perform diverse surgical applications.

- *Pure* provides an even cut with little or no hemostasis. It offers good cutting performance over a wide range of tissue resistance.
- *Blend* provides cutting ability with additional hemostasis.

Coag Modes

Two coagulation modes help control the size of the area and the depth of penetration during tissue coagulation. The low (desiccate) mode has three settings; the high (fulgurate) mode, two settings. You can select, as default settings, one low setting and one high setting. For a description of each setting, refer to *Special Features* in this section.

- *Low (desiccate)* dehydrates and destroys tissue without sparking or cutting. Because the active electrode directly touches the tissue, more current reaches the patient. Desiccation places the greatest demand on the patient return electrode.
- *High (fulgurate)* coagulates tissue by sparking from the active electrode, through air, to the patient tissue. In this mode, you have less control over sparking, thus it is best suited for coagulation of larger areas. Accidental sparking to adjacent areas can occur as tissue at the surgical site dries and becomes more resistant to current flow.

For details about the monopolar output characteristics, refer to Section 4, *Technical Specifications*.

REM Contact Quality Monitoring System

During monopolar electrosurgery, a patient return electrode is always required to safely recover the current that flows through the patient's body and return it to the generator. A reduction in surface area contact or poor conductivity between the patient and the return electrode can cause the current to become concentrated, potentially resulting in burns at the return electrode site.

The Force EZ-C Series Electrosurgical Generator uses the Valleylab REM Contact Quality Monitoring System to monitor the quality of electrical contact between the patient return electrode and the patient. The REM system is designed to eliminate the risk of burns at the return electrode site. Use of any return electrode other than a REM patient return electrode may compromise the REM safety feature. This could result in a patient burn.

How the REM System Works

The REM system continuously measures the resistance at the return electrode site and compares it to a standard range of safe resistance (between 5 and 135 ohms), thus eliminating intermittent false alarms that could result from small changes in resistance. The REM system also adapts to individual patients by measuring the initial contact resistance between the patient and the patient return electrode and lowering the baseline resistance if the contact resistance drops.

A REM alarm sounds and the generator stops producing output power when **either** of the following occurs:

- The measured resistance is below 5 ohms or above 135 ohms, the limits of the standard range of safe resistance.
- An increase in contact resistance is greater than 40% from the initial measurement (baseline resistance).

Electrodes Without the REM Safety Feature

Warning

Using a patient return electrode without the REM safety feature will not activate the Valleylab REM Contact Quality Monitoring System.

When you use a patient return electrode that does not have the REM safety feature, the REM system does not monitor the patient contact area as previously described. The REM system monitors only the pin-to-pin resistance at the connector and can detect broken wires or connectors in the return electrode cord.

Special Features

Five special features allow customizing the Force EZ-C Series Electrosurgical Generator. You can access these features only in the setup mode. For details on selecting these features, refer to *Setting Up the Special Features* in Chapter 4 of the User's Guide.

Low (Desiccate) Coag Settings

The low (desiccate) coag mode provides three settings with subtle differences in output characteristics:

- *Low 1* is appropriate for the majority of surgical procedures. It provides tissue desiccation with a minimal tendency to cut or spark.
- *Low 2* produces tissue desiccation and further reduces the chance of cutting or sparking by using the lowest possible voltage (ø 200 V_{rms}).
- *Low 3* uses a slightly higher voltage (ø 300 V_{rms}) than the low 2 setting, but offers comparable desiccation.

High (Fulgurate) Coag Settings

The high (fulgurate) coag mode provides two settings:

- *High 1* produces coagulation of smaller areas without touching the electrode tip to the tissue.
- *High 2* produces coagulation of larger areas without touching the electrode to the tissue.

Recall of Most Recently Used Modes and Power Settings

When you activate this feature, the generator will, when turned on, revert to the most recently used modes and power settings.

Default Coag Mode

Important

The default coag mode feature is available only when the most recently used modes and power settings feature is turned off.

You can select either low (desiccate) or high (fulgurate) as the default coag mode for the Force EZ-C Series Electrosurgical Generator. Each time you turn on the generator, it automatically selects the default coag mode.

Original Default Settings

This feature resets the generator to the original default setting for each mode, power setting, and special feature. The next time you turn on the generator, it automatically selects the original default settings.

Mode or Feature	Original Default Setting
Monopolar	Pure
Coag	High (fulgurate)
Low (desiccate) coag setting	1 (low 1)
High (fulgurate) coag setting	2 (high 2)
Last used modes and power settings	1 (on)

Controls, Indicators, and Receptacles

This section describes the front and rear panels, including all controls, indicators, and receptacles.

Front Panel

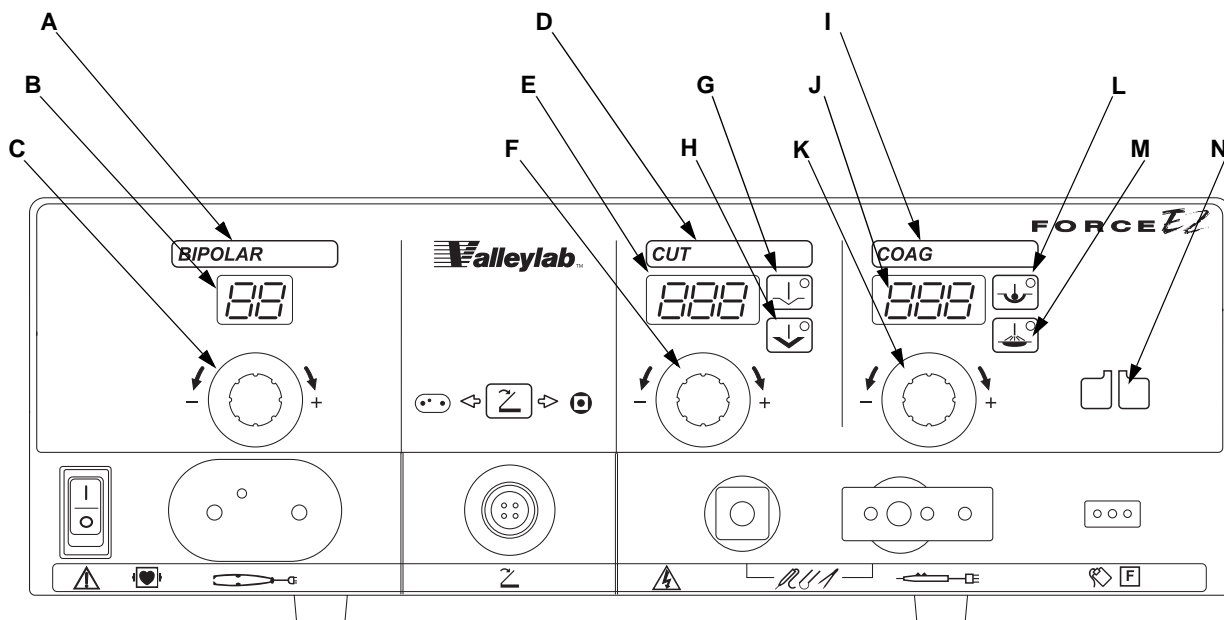

Figure 3-1.
The front panel

A. Bipolar Indicator

When you activate the generator in bipolar mode, this bar illuminates blue and an activation tone sounds.

B. Bipolar Display

Shows the power setting, in watts, for bipolar output.

C. Bipolar Power Control Knob

To increase (+) the power, turn the knob clockwise.

To decrease (-) the power, turn the knob counterclockwise.

D. Cut Indicator

When you activate the generator in cut mode, this bar illuminates yellow and an activation tone sounds.

E. Cut Display

Shows the power setting, in watts, for cut output.

F. Cut Power Control Knob

To increase (+) the power, turn the knob clockwise.

To decrease (-) the power, turn the knob counterclockwise.

G. Pure Button

Select for an even cut with little or no hemostasis.

H. Blend Button

Select for slower cutting and additional hemostasis.

I. Coag Indicator

When you activate the generator in coag mode, this bar illuminates blue and an activation tone sounds.

J. Coag Display

Shows the power setting, in watts, for coag output.

K. Coag Power Control Knob

To increase (+) the power, turn the knob clockwise.

To decrease (–) the power, turn the knob counterclockwise.

L. Low (Desiccate) Button

Select to desiccate the area of tissue that is in direct contact with the active electrode.

M. High (Fulgurate) Button

Select to fulgurate an area of tissue with a spray of sparks.

N. REM Alarm Indicator

This indicator illuminates red until you properly apply a REM patient return electrode to the patient and connect it to the generator. Then, the indicator illuminates green. (When you connect an electrode without the REM safety feature, the indicator light does not illuminate.)

If the REM system senses an alarm condition, the indicator flashes red until you correct the alarm condition – then the indicator illuminates green. (If you are using a return electrode without the REM safety feature, the red indicator is extinguished when you correct the alarm condition.)

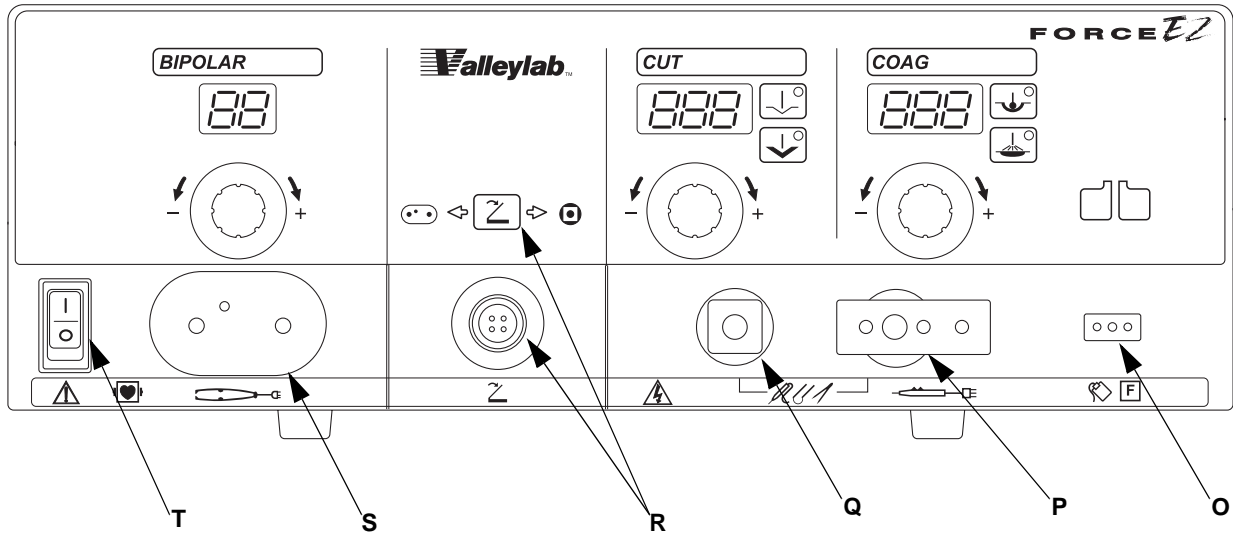

Figure 3-2.
The front panel - continued

O. Patient Return Electrode Receptacle

For monopolar electrosurgery, connect a patient return electrode to this receptacle.

P. Monopolar Instrument Receptacle

You can connect either a handswitching instrument (three-pin connector) or a footswitching instrument (single-pin connector) to this receptacle.

To activate a footswitching instrument, connect a monopolar footswitch to the rear panel.

Q. Accessory Instrument Receptacle

Connect a monopolar footswitching instrument with a single-pin connector to this receptacle.

To activate the instrument, connect a monopolar footswitch to the front panel.

R. Footswitch Receptacle, Button, and Indicators

Connect a two-pedal Valleylab monopolar footswitch to this receptacle. Press the Footswitch Selector button to select bipolar or accessory output.

Use only a Valleylab monopolar footswitch with the Force EZ-C Series Electrosurgical Generator. Use on an incompatible footswitch may cause unexpected output.

When the left arrow indicator illuminates green, the footswitch activates the instrument connected to the Bipolar Instrument receptacle.

When the right arrow indicator illuminates green, the footswitch activates the instrument connected to the Accessory Instrument receptacle.

The footswitch will not activate an instrument connected to the Monopolar Instrument receptacle.

S. Bipolar Instrument Receptacle

You can connect either a handswitching instrument (three-pin connector) or a footswitching instrument (two-pin connector) to this receptacle.

To activate a bipolar footswitching instrument, you can connect a bipolar footswitch to the rear panel or a monopolar footswitch to the front panel.

T. Power Switch

This switch supplies power to the generator.

To turn on the generator, press (|).

To turn off the generator, press (O).

Rear Panel

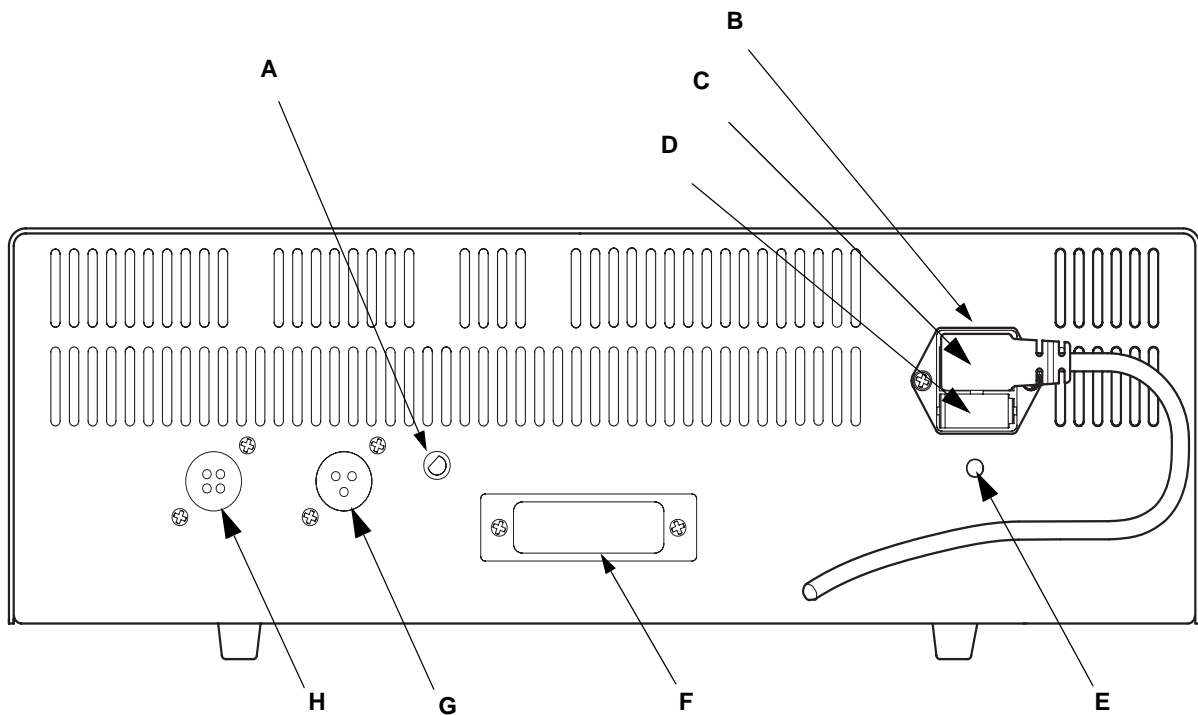

Figure 3-3.
Controls and receptacles on the rear panel

A. Volume Control

The Force EZ-C Series Electrosurgical Generator includes an audible tone that sounds in two circumstances:

- When you activate the generator
- When any alarm occurs

You can adjust the volume of the activation tones. However, to ensure that the surgical team is alerted to inadvertent activation, you cannot turn the activation tones off.

- To increase volume, turn the knob clockwise.
- To decrease volume, turn the knob counterclockwise.

You cannot adjust the alarm tone volume.

B. Power Entry Module

This module contains the power cord receptacle and the fuse drawer.

C. Power Cord Receptacle

The power cord provided with the generator connects to this receptacle.

D. Fuse Drawer

The fuse drawer contains two fuses. Refer to Section 8, *Replacement Procedures*, for instructions for changing the fuses.

E. Equipotential Grounding Lug

Use this lug to connect the generator to protective earth ground.

F. Option Panel

Refer to the next page for information about this panel.

G. Bipolar Footswitch Receptacle

Connect a single-pedal bipolar footswitch to this receptacle if you connect an instrument to the Bipolar Instrument receptacle on the front panel.

The footswitch will not activate instruments connected to the Monopolar Instrument or Accessory Instrument receptacles on the front panel.

H. Monopolar Footswitch Receptacle

Connect a two-pedal Valleylab monopolar footswitch to this receptacle if you connect an instrument to the Monopolar Instrument receptacle on the front panel.

The footswitch will not activate instruments connected to the Bipolar Instrument or Accessory Instrument receptacles on the front panel.

Option Panel

A removable plate on the rear panel covers a serial port and a radio frequency (RF) activation port. To review the technical specifications for each port, refer to Section 4, *Technical Specifications*.

Serial Port

Allows connection of a computer to the generator. You can obtain information about the generator using the RS-232 communications protocol.

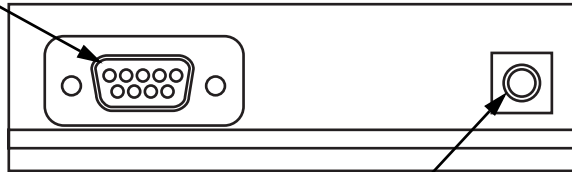

RF Activation Port

Allows a connected device to receive information during RF activation of the generator, which can then generate a response in the device.

Figure 3-4.
The option panel on the generator rear panel with the plate removed to show the serial and RF activation ports

Technical Specifications

All specifications are nominal and subject to change without notice. A specification referred to as “typical” is within $\pm 20\%$ of a stated value at room temperature (77° F/25° C) and a nominal input power voltage.

Performance Characteristics

General

Output configuration	isolated output
Cooling	natural convection; side and rear panel vents
Display	eight digital seven-segment displays: 1.9 cm (0.75 in.) each
Mounting	Valleylab Universal Cart (UC8009), Force Argon Unit, or any stable flat surface

Dimensions and Weight

Width	40.6 cm (16 in.)
Depth	39.5 cm (15.6 in.)
Height	12.7 cm (5 in.)
Weight	< 6.8 kg (< 15 lbs)

Operating Parameters

Ambient temperature range	10° to 40° C (50° to 104° F)
Relative humidity	30% to 75%, noncondensing
Atmospheric pressure	700 to 1060 millibars
Warm-up time	If you transported or stored the generator at temperatures outside the operating temperature range, allow one hour for the generator to reach room temperature before use.

Transport and Storage

Ambient temperature range	-34° to 65° C (-29° to 149° F)
Relative humidity	25% to 85%, noncondensing
Atmospheric pressure	500 to 1060 millibars
Duration of storage	If you stored the generator longer than one year, replace the battery for battery-backed RAM and complete a full test and recalibration before use. Refer to <i>Section 6, Setup, Tests, and Adjustments</i> for instructions.

Duty Cycle

Under maximum power settings and rated load conditions (pure cut, 300 watt setting, 300 ohm load), the Force EZ-C Series Electrosurgical Generator is suitable for activation times of 10 seconds on, 30 seconds off for one hour. With lesser settings and loads, you can activate the generator for greater durations without generating excessive internal temperatures.

If the internal temperature of the generator is too high, an alarm tone sounds and a number (451) flashes in the Cut display alternately with the power settings. You can activate the generator and change the power settings while this condition exists.

Internal Memory

Memory type	Nonvolatile, battery-backed RAM
Battery type	3 V lithium button cell
Battery life	5 years
Storage capacity	<ul style="list-style-type: none"> the last twenty error codes detected by the generator the number of times and length of activation for each mode the average power setting used for each mode the total time the generator is on calibration constants special features settings last setup parameters other service-related information

Audio Volume

The audio levels stated below are for activation tones (bipolar, cut, and coag) and alarm tones (REM and system alarms) at a distance of one meter. Alarm tones meet the requirements for IEC 60601-2-2 and AAMI HF18.

Activation Tone

Volume (adjustable)	45 to ≥ 65 dBA
Frequency	Bipolar: 554 Hz Cut: 440 Hz Coag: 554 Hz
Duration	continuous while the generator is activated

Alarm Tone

Volume (not adjustable)	≥ 65 dBA
Frequency	440 Hz
Duration	250 to 500 ms. The pulse train is repeated for REM and dosage error alarms at 30 second intervals.

REM Contact Quality Monitor

REM current is measured according to IEC 60601-1, Ed. 1988, Figure 15.

Measurement frequency	80 kHz \pm 10 kHz
Measurement current	$< 10 \mu\text{A}$

Acceptable Resistance Range

REM resistance measurements are $\pm 10\%$ during RF activation and $\pm 5\%$ when RF output is not activated.

REM patient return electrode: 5 to 135 ohms or up to a 40% increase in the initial measured contact resistance (whichever is less)

Patient return electrode without the REM safety feature (single section electrode): 0 to 20 ohms

If the measured resistance is outside the acceptable range(s) noted above, a REM fault condition occurs.

REM Alarm Activation

REM patient return electrode: When the measured resistance exceeds the standard range of safe resistance (below 5 ohms or above 135 ohms) or when the initial measured contact resistance increases by 40% (whichever is less), the REM Alarm indicator flashes red, a tone sounds twice, and the generator disables RF output. The indicator remains illuminated red until you correct the condition causing the alarm. Then, the indicator illuminates green and the generator enables RF output.

Patient return electrode without the REM safety feature: When the measured resistance between the patient return electrode pins exceeds 20 ohms, the REM Alarm indicator flashes red, a tone sounds twice, and the generator disables RF output. The indicator remains illuminated red until you correct the condition causing the alarm. Then, the red indicator is extinguished and the generator enables RF output.

Serial Port

RS-232 compatible; 9600 baud, 8 data bits, 1 stop bit, no parity

This port is a 9-pin connector supporting the following signals:

- pin 2 – isolated transmit (serial data output transmit line)
- pin 3 – isolated receive (serial data input receive line)
- pin 5 – isolated ground (reference for transmit and receive)

RF Activation Port

The RF activation port is a subminiature phone jack attached to the contacts of a small relay. The contacts close when you activate the generator, but remain open at all other times. This port provides a means to tell other equipment that the generator is producing RF. This may be useful when making EEG or ECG measurements.

Input Power

100–120 Volt	220–240 Volt
Maximum VA input: Idle: 50 VA Bipolar: 500 VA Cut: 850 VA Coag: 500 VA	Maximum VA input: Idle: 50 VA Bipolar: 500 VA Cut: 850 VA Coag: 500 VA
Full regulation range: 90–135 Vac	Full regulation range: 186–264 Vac
Operating range: 85–140 Vac	Operating range: 170–280 Vac
Mains current (maximum): Idle: 0.4 A Bipolar: 4.2 A Cut: 8.0 A Coag: 4.2 A	Mains current (maximum): Idle: 0.2 A Bipolar: 2.1 A Cut: 4.0 A Coag: 2.1 A
Mains line frequency range (nominal): 50 Hz to 60 Hz	Mains line frequency range (nominal): 50 Hz to 60 Hz
Mains fuse: F8.0 A	Mains fuse: T4.0 A
Power plug: 3-prong hospital grade connector	Power plug: 3-prong locally approved connector

Power Cord Specification

This unit was equipped from the factory with either a 110VAC hospital grade NEMA 5-15 power cord or a 220VAC CEE7/7 power cord. Should the AC power cord need to be replaced to match another plug configuration, the replacement plug/cable/receptacle configuration must meet or exceed the following specifications:

100-120 VAC

Cable - SJT16/3, IEC color code, maximum length 15 ft (5 m)

Plug - minimum 10 A - 125 VAC

Unit receptacle - IEC female, minimum 10 A - 125 VAC

220-240 VAC

Cable - H05VVVF3G1.0 VDE, maximum length 15' (5 meters)

Plug - minimum 6 A - 250VAC

Unit receptacle - IEC female, minimum 6 A - 250VAC

Low Frequency (50-60 Hz) Leakage Current

Enclosure source current, ground open	< 100 μA
--	---------------------

Source current, patient leads, all outputs	Normal polarity, intact ground: < 10 μA
	Normal polarity, ground open: < 50 μA
	Reverse polarity, ground open: < 50 μA

Sink current at high line, all inputs	< 20 μA
--	--------------------

High Frequency (RF) Leakage Current

Bipolar RF leakage current	< 60 mA_{rms}
-----------------------------------	-------------------------------

Monopolar RF leakage current	< 150 mA_{rms}
-------------------------------------	--------------------------------

Standards and IEC Classifications

The Force EZ-C Series Electrosurgical Generator meets all pertinent clauses of the IEC 60601-1 second edition and IEC 60602-2-2 third edition.



ATTENTION

Consult accompanying documents.



The generator output is floating (isolated) with respect to ground.



DANGER

Explosion risk if used with flammable anesthetics.



Rear Panel—To reduce the risk of electric shock, do not remove the cover. Refer servicing to qualified service personnel.

Front Panel—Dangerous Voltage Output.



Non-Ionizing Radiation



Classified with respect to electrical shock, fire, and mechanical hazards only in accordance with UL60601-1 and CAN/CSA C22.2 No. 601.1.

Class I Equipment (IEC 60601-1)

Accessible conductive parts cannot become live in the event of a basic insulation failure because of the way in which they are connected to the protective earth conductor.

Type CF Equipment (IEC 60601-1)/Defibrillator Proof



The Force EZ-C Series Electrosurgical Generator provides a high degree of protection against electric shock, particularly regarding allowable leakage currents. It is type CF isolated (floating) output and may be used for procedures involving the heart.

The Force EZ-C Series Electrosurgical Generator patient return electrode terminal is protected from defibrillator discharge according to ANSI/AAMI HF18 and IEC 60601-2-2.

Liquid Spillage (IEC 60601-2-2 Clause 44.3)

The Force EZ-C Series Electrosurgical Generator enclosure is constructed so that liquid spillage in normal use does not wet electrical insulation or other components which, when wetted, are likely to adversely affect the safety of the equipment.

Electromagnetic Interference

The Force EZ-C Series Electrosurgical Generator minimizes electromagnetic interference to video equipment used in the operating room. The generator complies with the requirements of IEC 61000-4-2.

Electromagnetic Compatibility (IEC 60601-1-2 and IEC 60601-2-2)

The Force EZ-C Series Electrosurgical Generator meets IEC 60601-1-2 and IEC 60601-2-2 requirements for electromagnetic compatibility.

Notice

The Force EZ should not be used adjacent to or stacked with equipment other than specified in the Force EZ User Guide and Service Manual. If adjacent or stacked use is necessary, the Force EZ should be observed to verify normal operation in the configuration in which it will be used.

The Force EZ intentionally applies RF energy for diagnosis or treatment during activation. Observe other electronic medical equipment in the vicinity during the Force EZ activation for any possible adverse electromagnetic effects. Ensure adequate separation of electronic medical equipment based on observed reactions.

The use of accessories, other than specified in the Force EZ User Guide and Service Manual, may result in increased emissions or decreased immunity of the Force EZ.

Voltage Transients (Emergency Generator Mains Transfer)

The Force EZ-C Series Electrosurgical Generator operates in a safe manner when you transfer between line AC and an emergency generator voltage source.

Guidance and manufacturer's declaration - electromagnetic emissions		
<p>The Force EZ-C Series Electrosurgical Generator is intended for use in the electromagnetic environment specified below. The customer or the user of the Force EZ-C Series Electrosurgical Generator should ensure that it is used in such an environment.</p>		
Emissions test	Compliance	Electromagnetic environment - guidance
RF emissions CISPR 11	Group 1	The Force EZ-C Series Electrosurgical Generator uses RF energy only for its internal function. Therefore, its RF emissions are very low and are not likely to cause any interference in nearby electronic equipment.
RF emissions CISPR 11	Class A	The Force EZ-C Series Electrosurgical Generator is suitable for use in all establishments other than domestic and those directly connected to the public low-voltage power supply network that supplies buildings used for domestic purposes.
Harmonic emissions IEC 61000-3-2	Class A	
Voltage fluctuations/ flicker emissions IEC61000-3-3	Complies	

Guidance and manufacturer's declaration - electromagnetic immunity			
The Force EZ-C Series Electrosurgical Generator is intended for use in the electromagnetic environment specified below. The customer or the user of the Force EZ-C Series Electrosurgical Generator should assure that it is used in such an environment.			
Immunity test	IEC 60601 test level	Compliance level	Electromagnetic environment - guidance
Electrostatic discharge (ESD) IEC 61000-4-2	+/-6 kV contact +/-8 kV air	+/-6 kV contact +/-8 kV air	Floors should be wood, concrete or ceramic tile. If floors are covered with synthetic material, the relative humidity should be at least 30%.
Electrical fast transient/burst IEC 61000-4-4	+/-2 kV for power supply lines +/-1 kV for input/output lines	+/-2 kV for power supply lines +/-1 kV for input/output lines	Mains power quality should be that of a typical commercial or hospital environment.
Surge IEC 61000-4-5	+/-1 kV differential mode +/-2 kV common mode	+/-1 kV differential mode +/-2 kV common mode	Mains power quality should be that of a typical commercial or hospital environment.
Voltage dips, short interruptions and voltage variations on power supply input lines IEC 61000-4-11	<5% Ut (>95% dip in Ut) for 0,5 cycle 40% Ut (>60% dip in Ut) for 5 cycles 70% Ut (>30% dip in Ut) for 25 cycles <5% Ut (>95% dip in Ut) for 5 sec	<5% Ut (>95% dip in Ut) for 0,5 cycle 40% Ut (>60% dip in Ut) for 5 cycles 70% Ut (>30% dip in Ut) for 25 cycles <5% Ut (>95% dip in Ut) for 5 sec	Mains power quality should be that of a typical commercial or hospital environment. If the user of the Force EZ-C Series Electrosurgical Generator requires continued operation during power mains interruptions, it is recommended that the Force EZ-C Series Electrosurgical Generator be powered from an uninterruptible power supply or a battery.
Power frequency (50/60 Hz) magnetic field IEC 61000-4-8	3 A/m	3 A/m	Power frequency magnetic fields should be at levels characteristic of a typical location in a typical commercial or hospital environment.
NOTE: Ut is the a.c. mains voltage prior to the application of the test level.			

Guidance and manufacturer's declaration - electromagnetic immunity			
The Force EZ-C Series Electrosurgical Generator is intended for use in the electromagnetic environment specified below. The customer or the user of the Force EZ-C Series Electrosurgical Generator should assure that it is used in such an environment.			
Immunity test	IEC 60601 test level	Compliance level	Electromagnetic environment - guidance
Conducted RF IEC 61000-4-6 Radiated RF IEC 61000-4-3	3 Vrms 150KHz to 80MHz 3 V/m 80MHz to 2.5GHz	7 V 7 V/m	<p>Portable and mobile RF communications equipment should be used no closer to any part of the Force EZ-C Series Electrosurgical Generator, including cables, than the recommended separation distance calculated from the equation applicable to the frequency of the transmitter.</p> <p>Recommended separation distance</p> $d=0.5\sqrt{P}$ $d=0.5\sqrt{P} \text{ 80MHz to 800MHz}$ $d=\sqrt{P} \text{ 800MHz to 2.5GHz}$ <p>Where P is the maximum output power rating of the transmitter in watts (W) according to the transmitter manufacturer and d is the recommended separation distance in meters (m).</p> <p>Field strengths from fixed RF transmitters, as determined by an electromagnetic site survey, should be less than the compliance level in each frequency range</p> <p>Interference may occur in the vicinity of equipment marked with the following symbol:</p> 
<p>NOTE 1 At a 80MHz and 800MHz, the higher frequency range applies.</p> <p>NOTE 2 These guidelines may not apply in all situations. Electromagnetic propagation is affected by absorption and reflection from structures, objects and people.</p>			
<p>a. Field strengths from fixed transmitters, such as base stations for radio (cellular/cordless) telephones and land mobile radios, amateur radio, AM and FM radio broadcast and TV broadcast cannot be predicted theoretically with accuracy. To assess the electromagnetic environment due to fixed RF transmitters, an electromagnetic site survey should be considered. If the measured field strength in the location in which the Force EZ-C Series Electrosurgical Generator is used exceeds the applicable RF compliance level above, the Force EZ-C Series Electrosurgical Generator should be observed to verify normal operation. If abnormal performance is observed, additional measures may be necessary, such as reorienting or relocating the Force EZ-C Series Electrosurgical Generator.</p> <p>b. Over the frequency range 150kHz to 80MHz, field strengths should be less than 7V/m.</p>			

Recommended separation distances between portable and mobile RF communication equipment and the Force EZ-C Series Electrosurgical Generator

The Force EZ-C Series Electrosurgical Generator is intended for use in an electromagnetic environment in which radiated RF disturbances are controlled. The Customer or the user of the Force EZ-C Series Electrosurgical Generator can help prevent electromagnetic interferences by maintaining a minimum distance between portable and mobile RF communications equipment (transmitters) and the Force EZ-C Series Electrosurgical Generator as recommended below, according to the maximum output power of the communications equipment.

Rated maximum output power of transmitter (W)	Separation distance according to frequency of transmitter (m)		
	150 kHz to 80MHz $d=0.5\sqrt{P}$	80MHz to 800MHz $d=0.5\sqrt{P}$	800MHz to 2.5GHz $d=\sqrt{P}$
0.01	0.05 m	0.05 m	0.1 m
0.1	0.16 m	0.16 m	0.32 m
1	0.5 m	0.5 m	1 m
10	1.6 m	1.6 m	3.2 m
100	5 m	5 m	10 m

For transmitters rated at a maximum output power not listed above, the recommended separation distance d in meters (m) can be estimated using the equation applicable to the frequency of the transmitter, where P is the maximum output power rating of the transmitter in watts (W) according to the transmitter manufacturer.

NOTE 1 At a 80MHz and 800MHz, the separation distance for the higher frequency range applies.

NOTE 2 These guidelines may not apply in all situations. Electromagnetic propagation is affected by absorption and reflection from structures, objects and people.

Output Characteristics

Available Power Settings in Watts

Bipolar

1	2	3	4	5	6	7	8	9	10
11	12	13	14	15	16	17	18	19	20
21	22	23	24	25	26	27	28	29	30
31	32	33	34	35	36	37	38	39	40
45	50	55	60	65	70				

Monopolar Cut: Pure

1	2	3	4	5	6	7	8	9	10
11	12	13	14	15	16	17	18	19	20
21	22	23	24	25	26	27	28	29	30
31	32	33	34	35	36	37	38	39	40
45	50	55	60	65	70	75	80	85	90
95	100	110	120	130	140	150	160	170	180
190	200	210	220	230	240	250	260	270	280
290	300								

Monopolar Cut: Blend

1	2	3	4	5	6	7	8	9	10
11	12	13	14	15	16	17	18	19	20
21	22	23	24	25	26	27	28	29	30
31	32	33	34	35	36	37	38	39	40
45	50	55	60	65	70	75	80	85	90
95	100	110	120	130	140	150	160	170	180
190	200								

Monopolar Coag

1	2	3	4	5	6	7	8	9	10
11	12	13	14	15	16	17	18	19	20
21	22	23	24	25	26	27	28	29	30
31	32	33	34	35	36	37	38	39	40
45	50	55	60	65	70	75	80	85	90
95	100	110	120						

Maximum Output for Force EZ-C Series Electrosurgical Generator Modes

Power readouts agree with actual power into rated load to within 15% or 5 watts, whichever is greater.

Mode	Open Circuit P-P Voltage (max)	Rated Load (max)	Power (max)	Crest Factor ^a (typical @ Rated Load)
Bipolar	300 V	100 Ω	70 W	1.5
Monopolar Cut				
<i>Pure</i>	2000 V	300 Ω	300 W	1.5
<i>Blend</i>	3400 V	300 Ω	200 W	2.1
Monopolar Coag				
<i>Low 1</i>	3500 V	500 Ω	120 W	5.0
<i>Low 2</i>	660 V	300 Ω	120 W	1.5
<i>Low 3</i>	1100 V	300 Ω	120 W	1.5
<i>High 1</i>	6000 V	500 Ω	120 W	4.9
<i>High 2</i>	8500 V	500 Ω	120 W	7.0

a. An indication of a waveform's ability to coagulate bleeders without a cutting effect

Output Waveforms

Instant Response Technology, an automatic adjustment, applies to the bipolar mode, the cut modes, and the low 2 and low 3 coag settings. It does not apply to the low 1, high 1, and high 2 coag settings. As tissue resistance increases, the generator produces constant current followed by constant power followed by constant voltage. The generator controls maximum output voltage to reduce capacitive coupling and video interference, and to minimize sparking.

Bipolar

<i>Standard</i>	470 kHz sinusoid
------------------------	------------------

Monopolar Cut

<i>Pure</i>	393 kHz sinusoid
--------------------	------------------

<i>Blend</i>	393 kHz bursts of sinusoid recurring at 27.1 kHz intervals, 50% duty cycle
---------------------	--

Monopolar Coag

<i>Desiccation</i>	
---------------------------	--

<i>Low 1</i>	240 \pm 40 kHz sinusoid recurring at 39 kHz. 8% duty cycle at open load
---------------------	--

<i>Low 2</i>	393 kHz sinusoid
---------------------	------------------

<i>Low 3</i>	393 kHz sinusoid
---------------------	------------------

<i>Fulguration</i>	
---------------------------	--

<i>High 1</i>	470 kHz damped sinusoidal bursts with a repetition frequency of 57 kHz at open load
----------------------	---

<i>High 2</i>	470 kHz damped sinusoidal bursts with a repetition frequency of 30 kHz at open load
----------------------	---

Output Power vs. Resistance Graphs

The graphs that follow depict the changes for each mode at specific power settings.

Bipolar Graph

The insulating surface described in IEC 60601-2-2 and full length leads was used to obtain the bipolar output measurements.

Figure 4-1.
Standard Bipolar mode — load resistance vs. output power

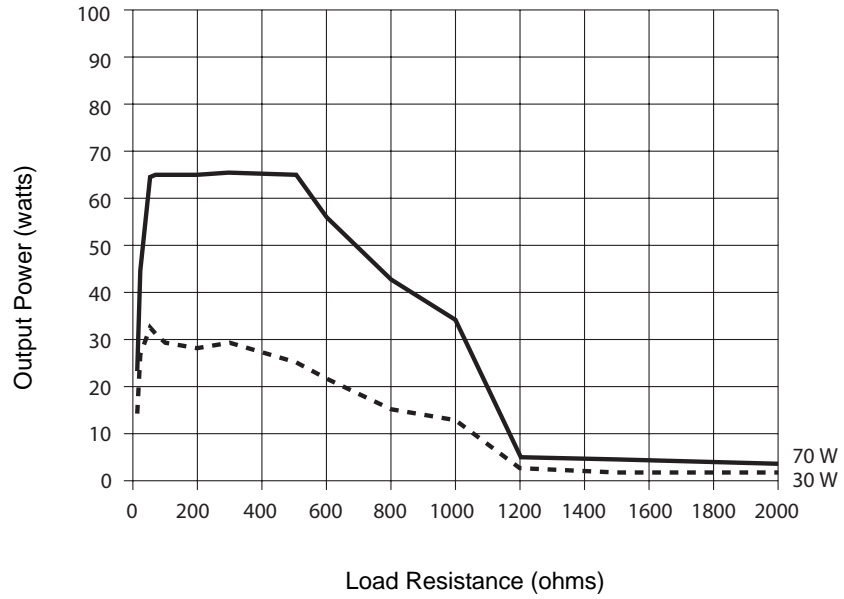

Monopolar Cut Graphs

Valleylab used the procedures described in IEC 60601-2-2 and full length leads to obtain the monopolar cut output measurements.

Figure 4-2.
Pure mode — load resistance vs.
output power

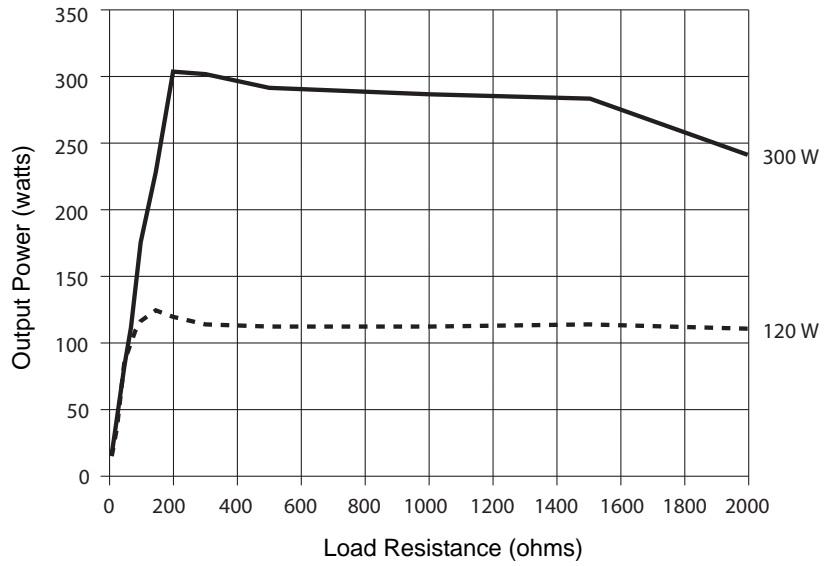
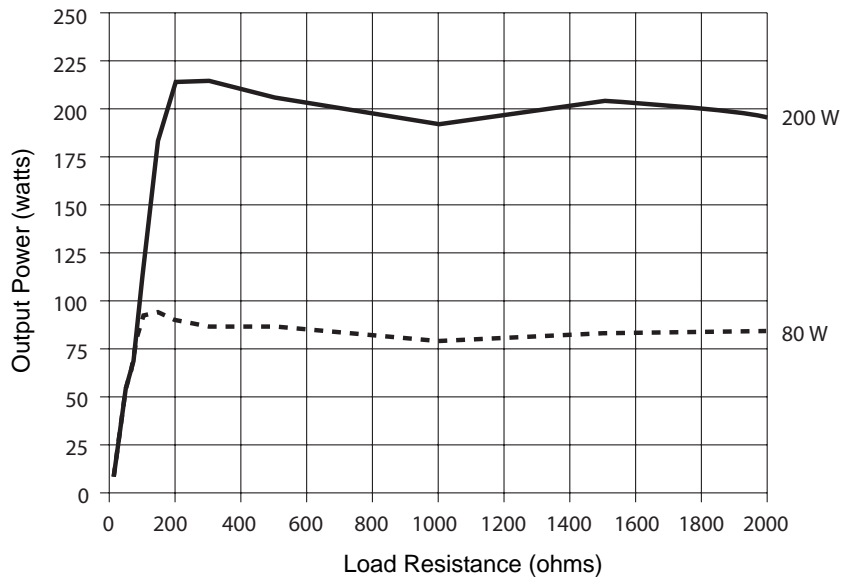

Figure 4-3.
Blend mode — load resistance
vs. output power



Monopolar Coag Graphs

The procedures described in IEC 60601-2-2 and full length leads were used to obtain the monopolar coag output measurements.

Figure 4-4.
Low 1 (Desiccate) mode — load resistance vs. output power

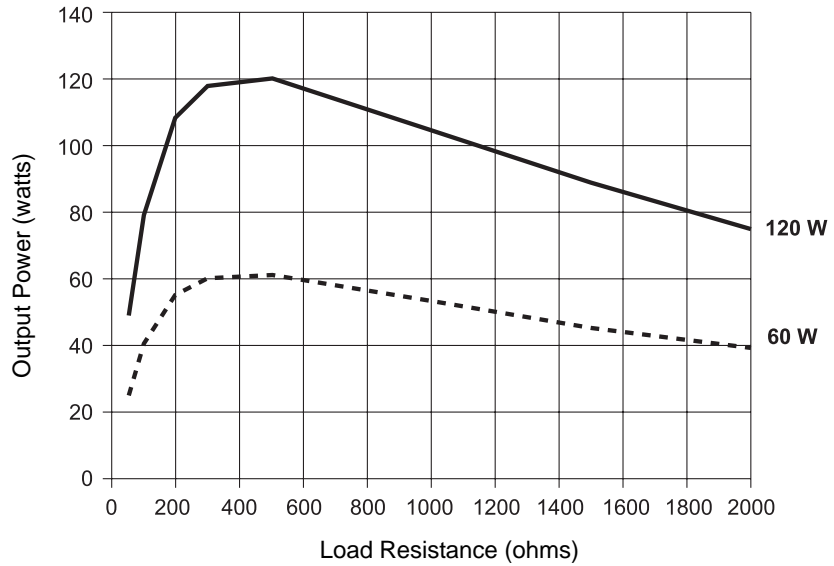

Figure 4-5.
Low 2 (Desiccate) mode — load resistance vs. output power

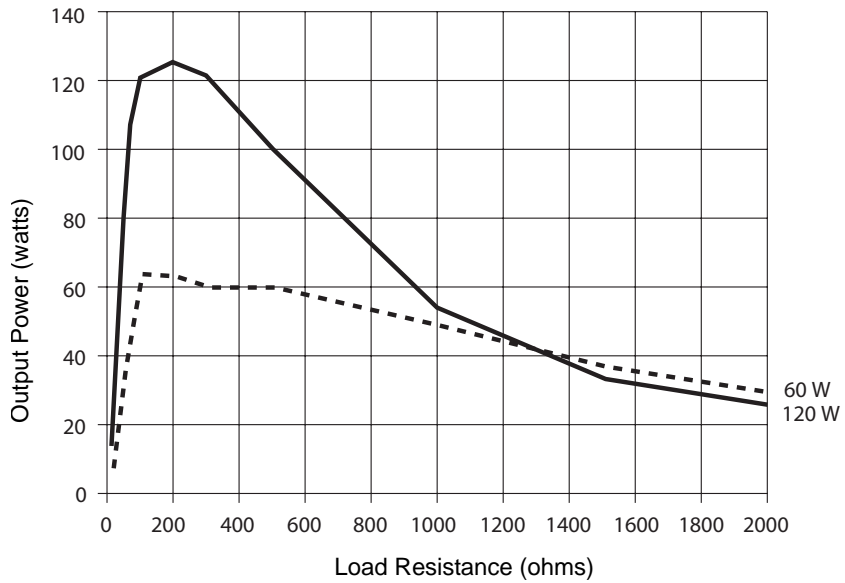

Figure 4-6.
Low 3 (Desiccate) mode — load
resistance vs. output power

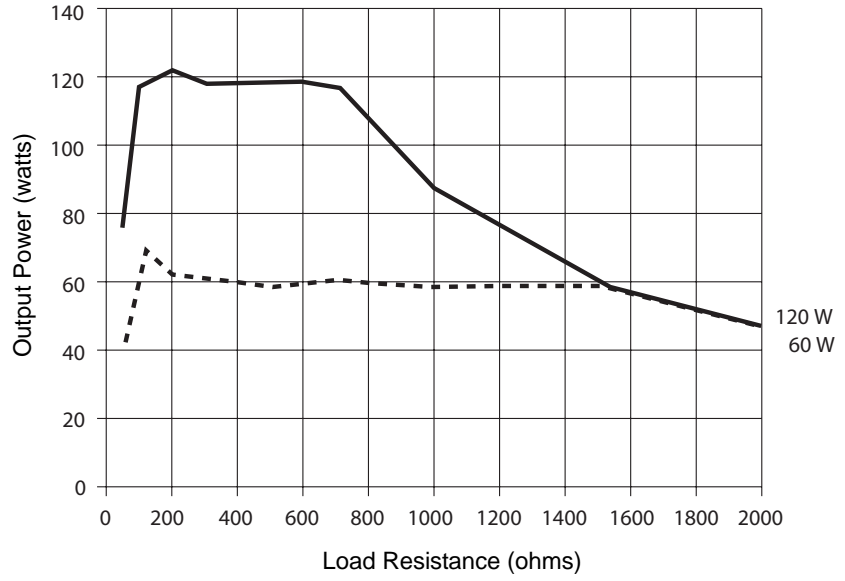

Figure 4-7.
High 1 (Fulgurate) mode — load
resistance vs. output power

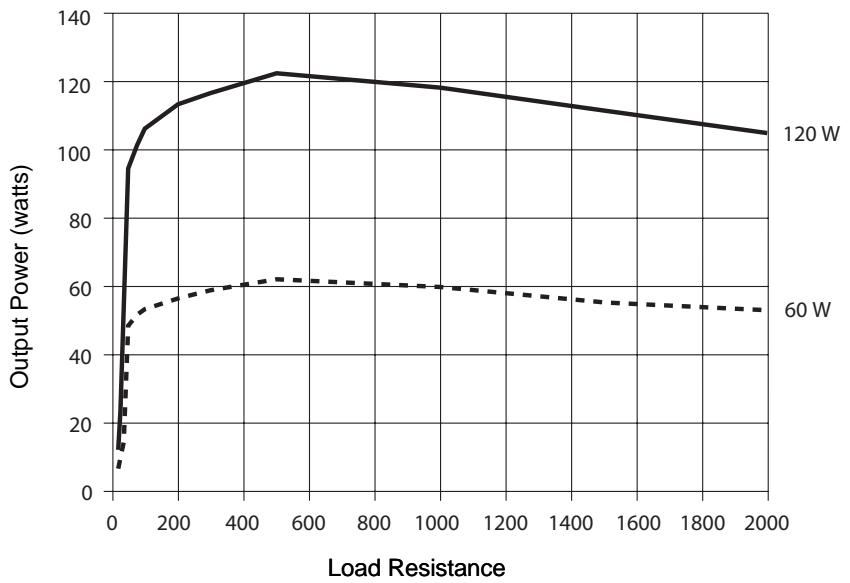
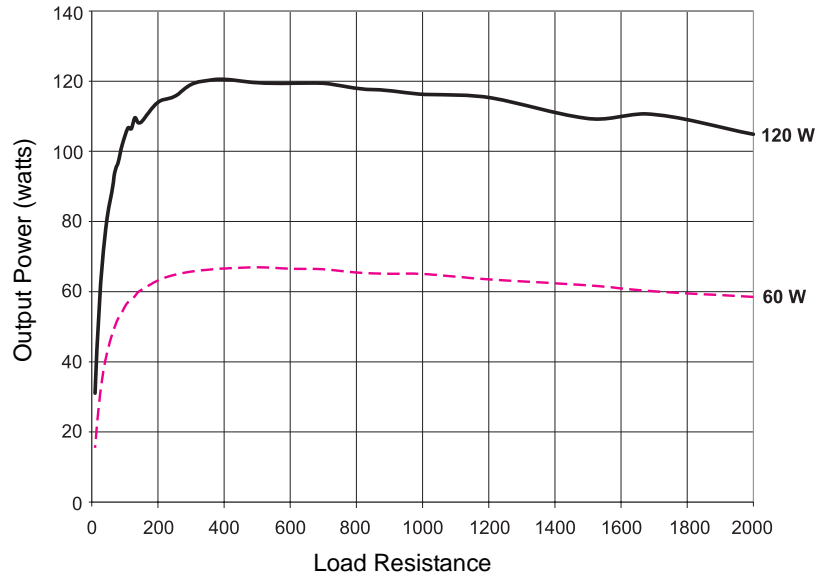

Figure 4-8.
High 2 (Fulgurate) mode — load
resistance vs. output power



Output Power vs. Generator Settings

Figure 4-9.
Standard Bipolar mode
@ 100 ohms — generator setting
vs. output power

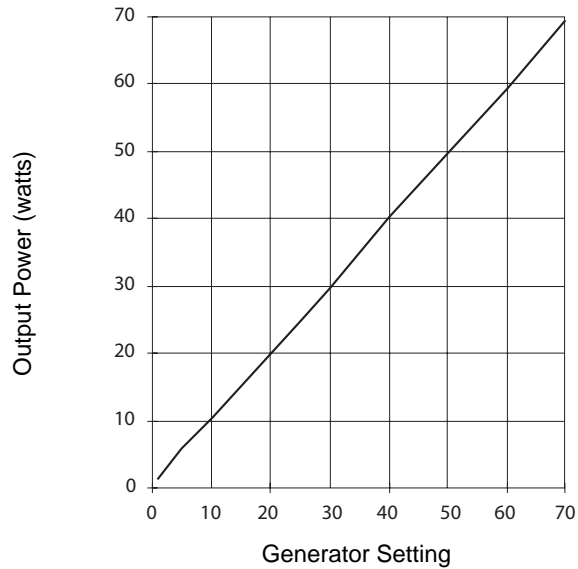

Figure 4-10.
Standard Bipolar mode — peak
voltage vs. output power

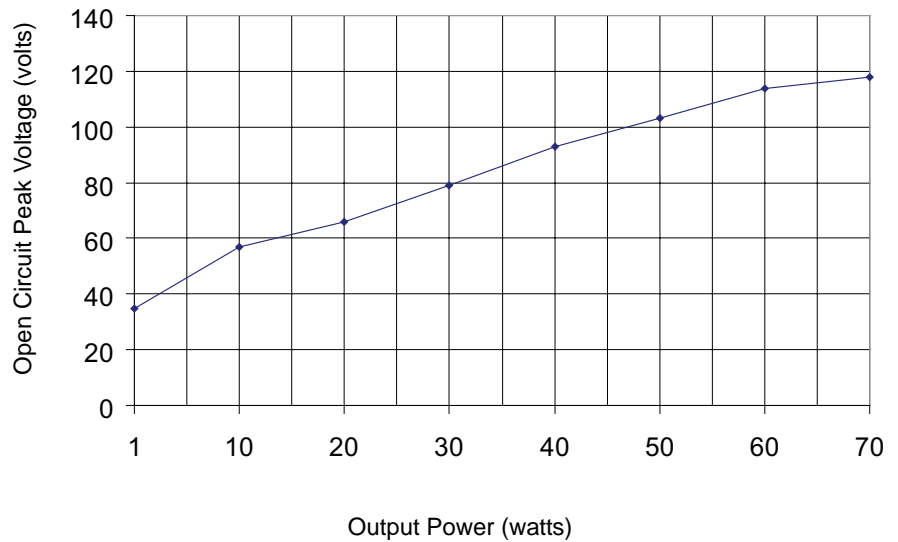

Figure 4-11.
 Pure mode @ 300 ohms —
 generator setting vs. output power

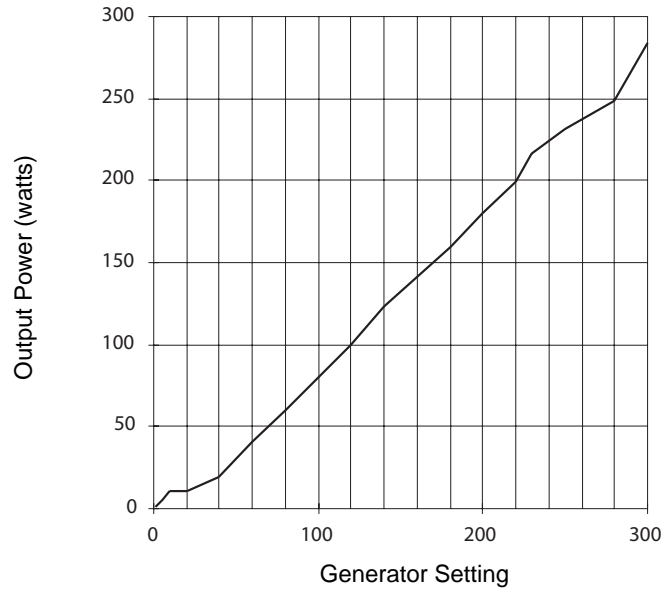

Figure 4-12.
 Pure mode — peak voltage vs.
 output power

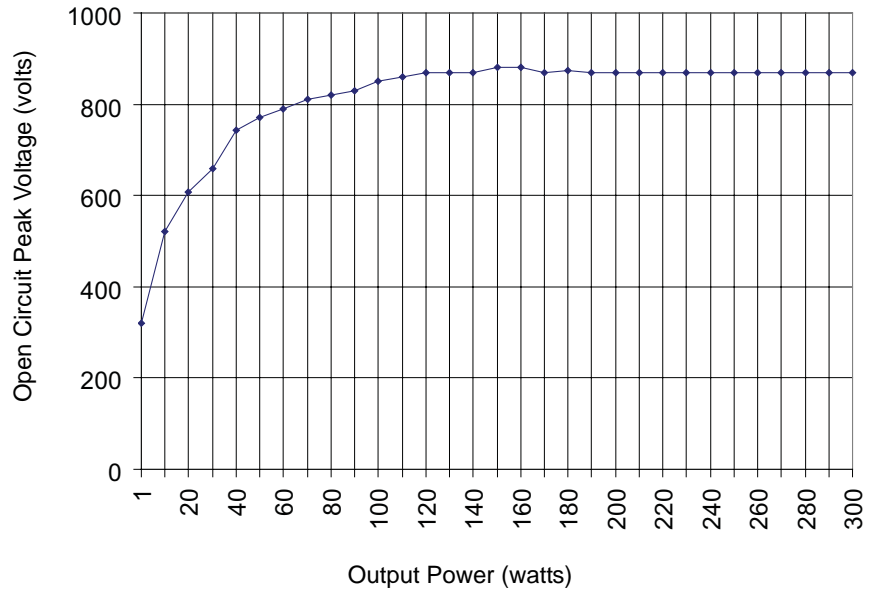

Figure 4-13.
Blend mode @ 300 ohms —
generator setting vs. output power

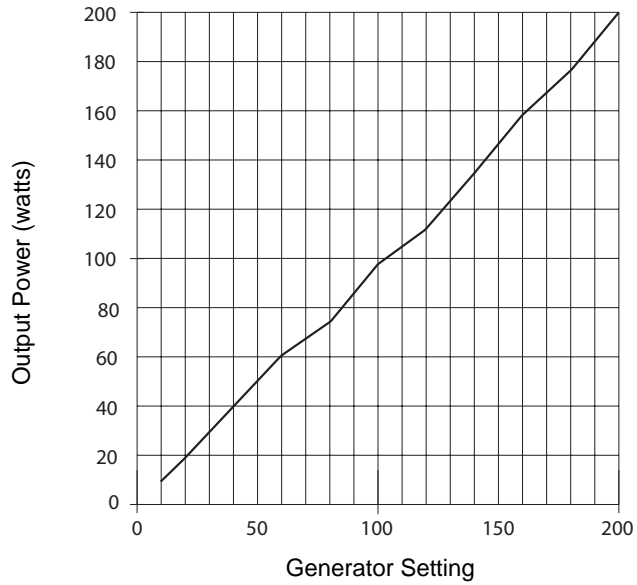

Figure 4-14.
Blend mode — peak voltage vs.
output power

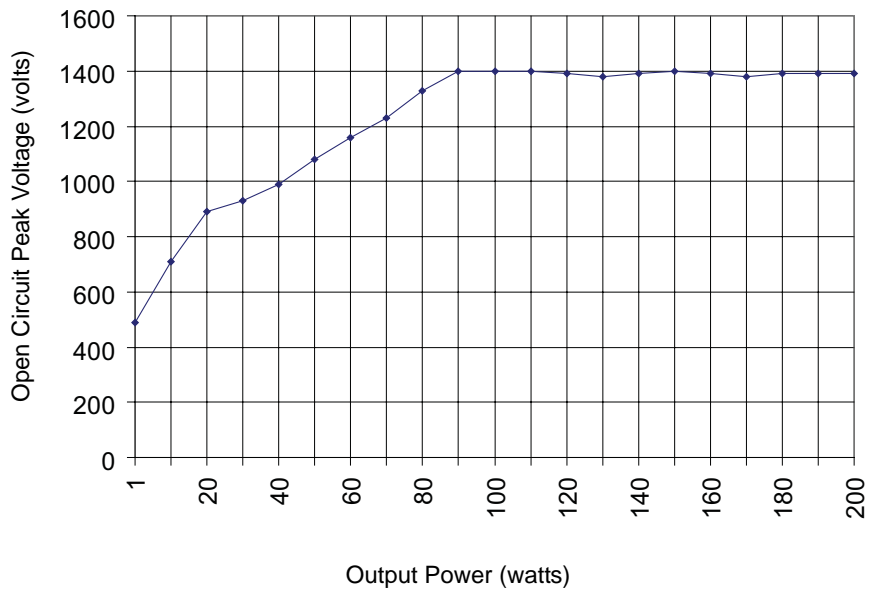

Figure 4-15.
 Low 1 (Desiccate) mode
 @ 500 ohms — generator setting
 vs. output power

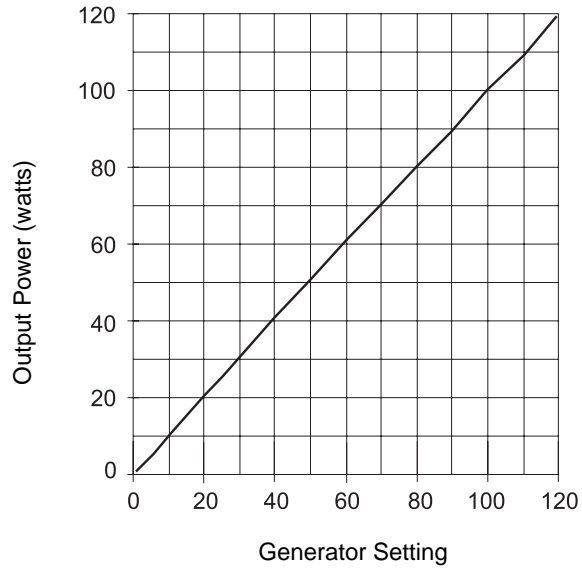

Figure 4-16.
 Low 1 (Desiccate) mode — peak
 voltage vs. output power

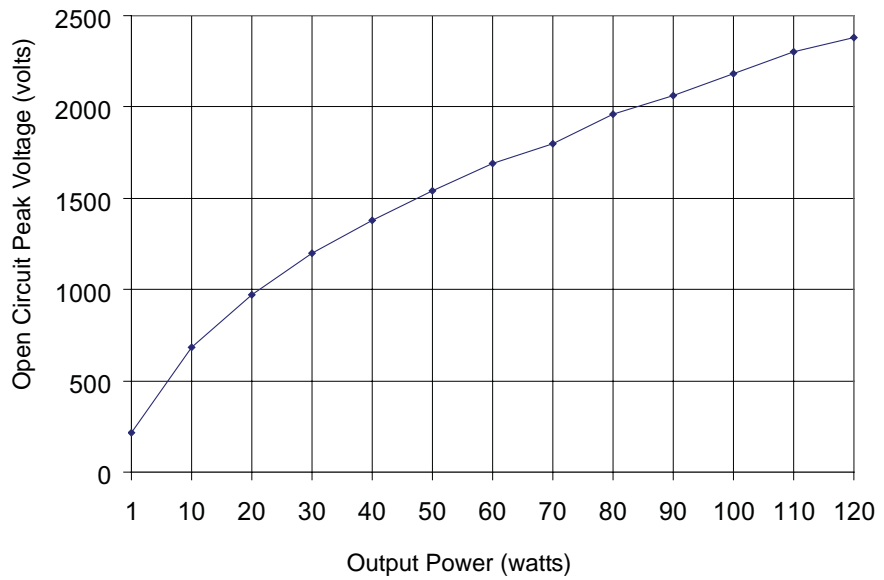

Figure 4-17. Low 2 (Desiccate) mode @ 300 ohms— generator setting vs. output power

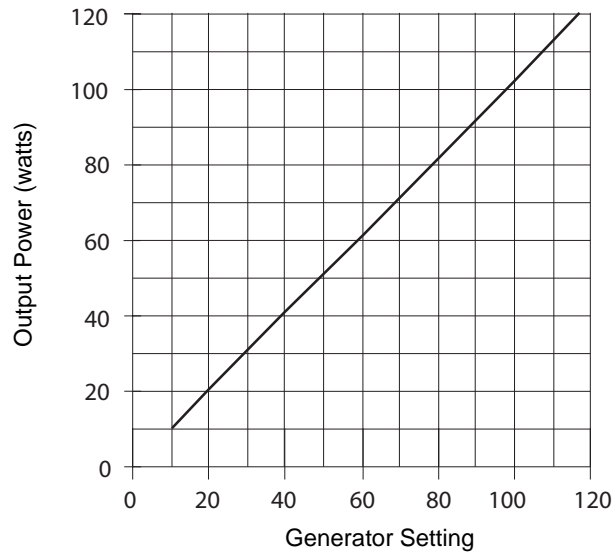

Figure 4-18. Low 2 (Desiccate) mode — peak voltage vs. output power

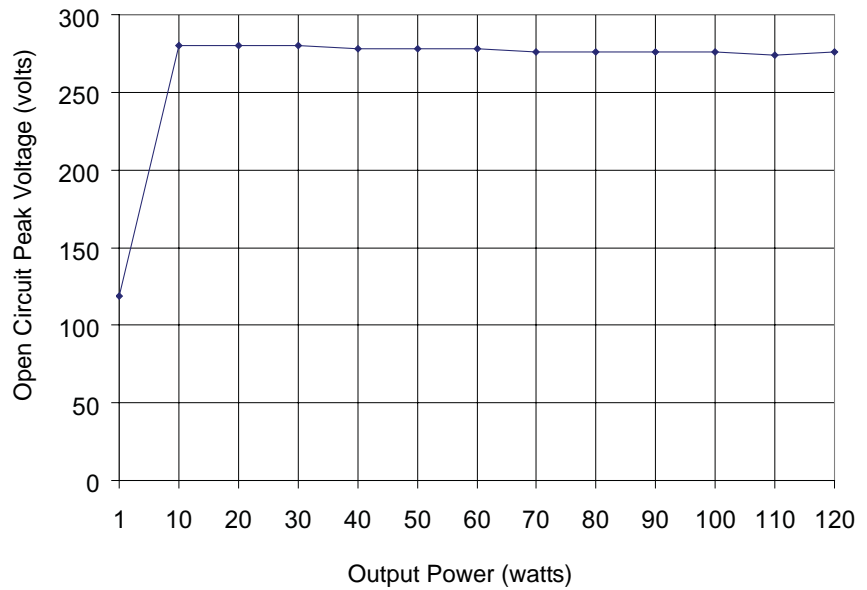

Figure 4-19.
 Low 3 (Desiccate) mode
 @ 300 ohms— generator setting
 vs. output power

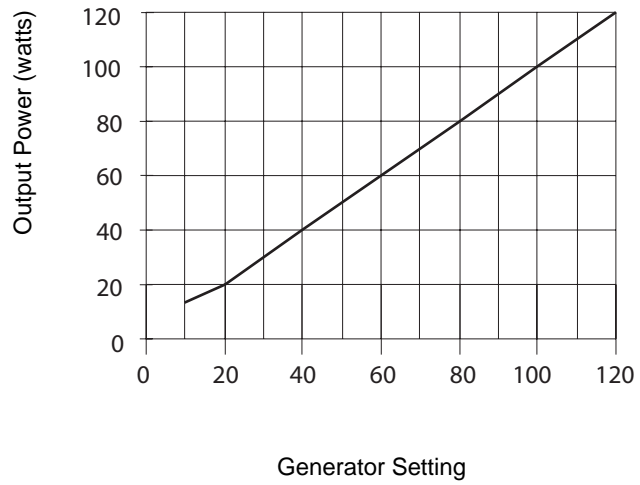

Figure 4-20.
 Low 3 (Desiccate) mode — peak
 voltage vs. output power

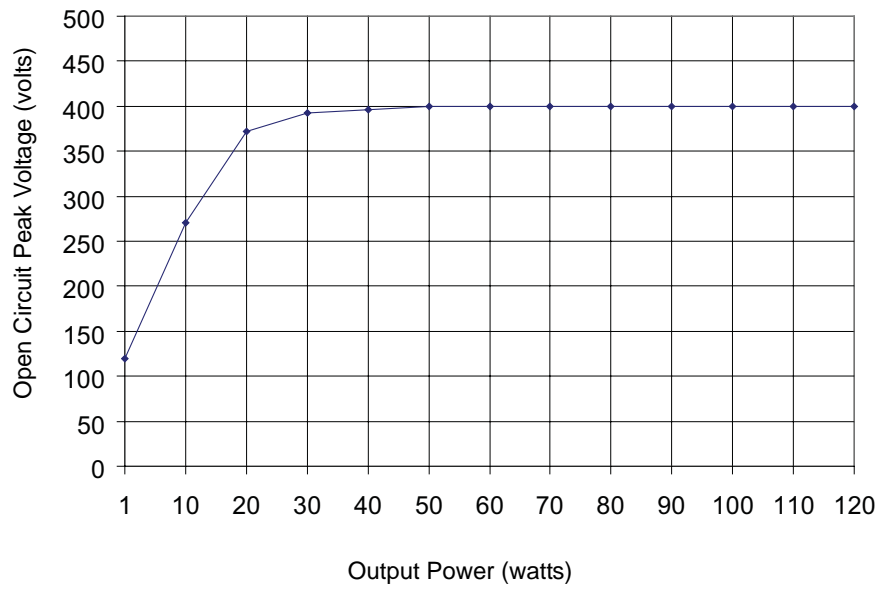

Figure 4-21.
High 1 (Fulgurate) mode
@ 500 ohms— generator setting
vs. output power

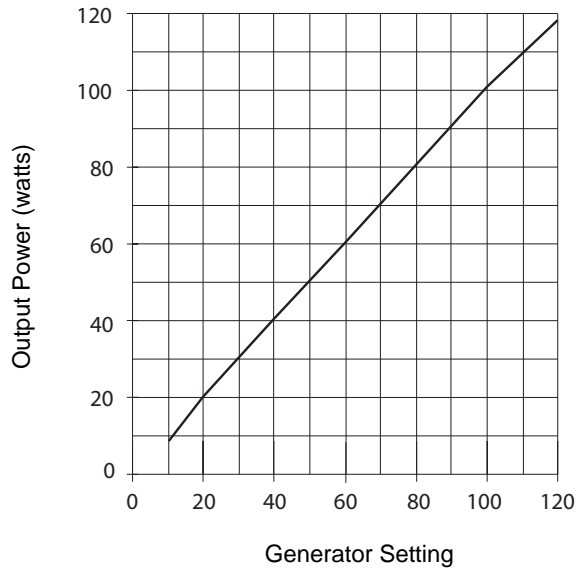

Figure 4-22.
High 1 (Fulgurate) mode — peak
voltage vs. output power

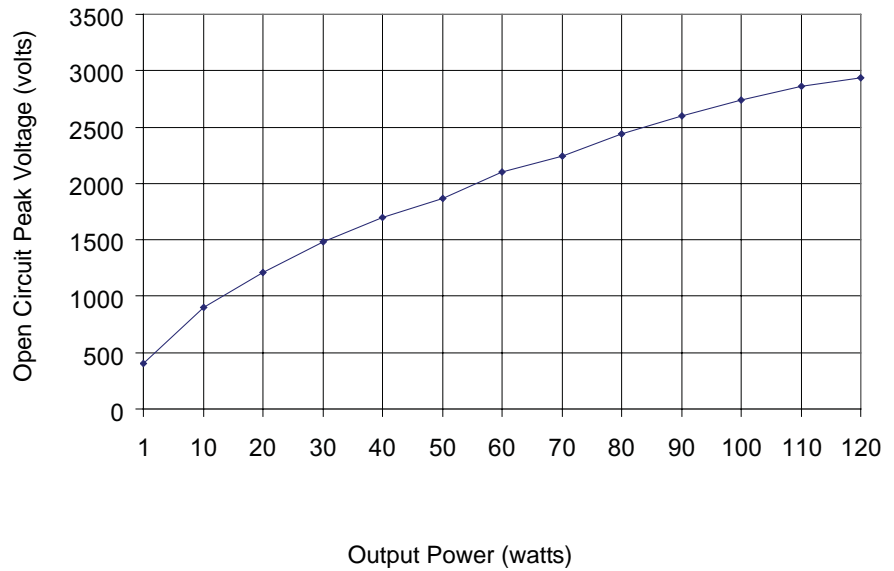

Figure 4-23.
 High 2 (Fulgurate) mode
 @ 500 ohms— generator setting
 vs. output power

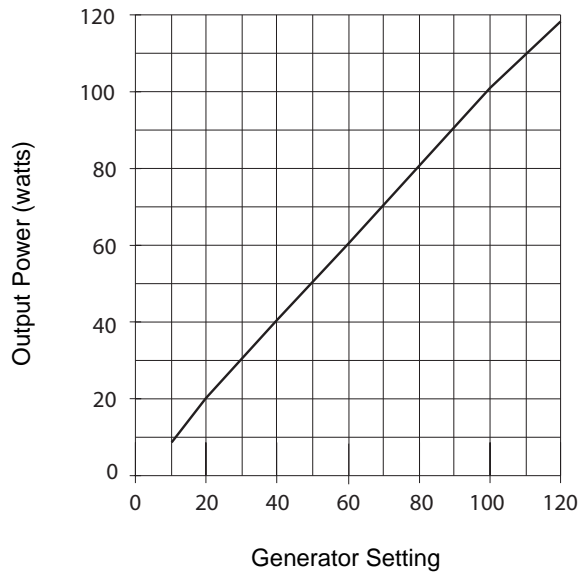
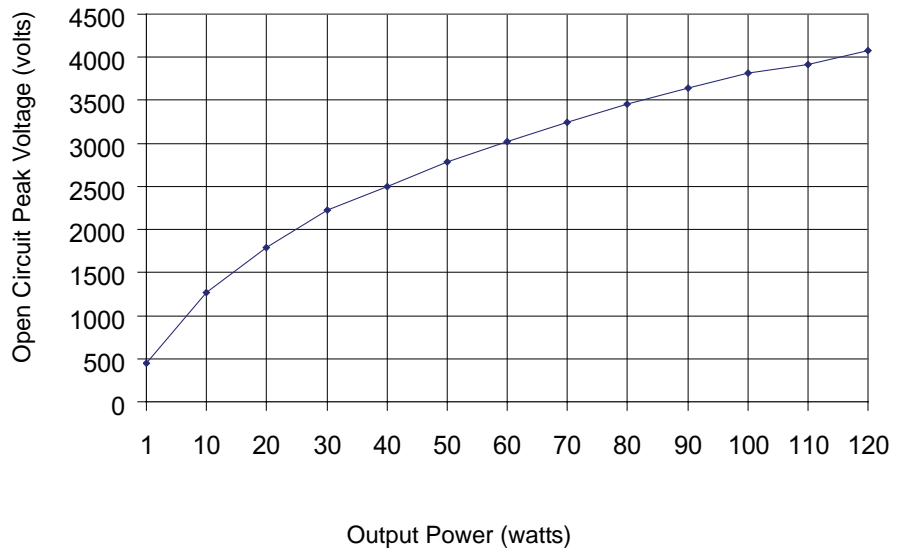

Figure 4-24.
 High 2 (Fulgurate) mode — peak
 voltage vs. output power





Principles of Operation

This section provides detailed information about how the Force EZ-C Electrosurgical Generator functions and how the internal components of the generator interact.

The Force EZ-C Series Electrosurgical Generator circuitry resides on four printed circuit boards: the Control board, the Display board, the Footswitch board, and the power supply/radio frequency (RF) board.

This section includes the following information:

- a block diagram that illustrates how the generator functions
- an overview that describes, in general terms, the functionality of the generator
- detailed descriptions of the circuitry for each Printed Circuit board

Functional Overview

The Valleylab Force EZ-C Series Electrosurgical Generator is specifically designed for use in bipolar or monopolar electrosurgery to cut and coagulate (desiccate and fulgurate) tissue. In electrosurgery, radio frequency (RF) current flows from the generator to an active electrode, which delivers the current to the patient. The resistance to the current, provided by the patient's tissue and/or the air between the active electrode and the tissue, produces the heat that is necessary for the surgical effect. The RF current flows from the active electrode through the patient's body tissue to the return electrode, which recovers the current and returns it to the generator.

Instant Response Technology

The Force EZ-C Series Electrosurgical Generator automatically senses resistance and adjusts the current and output voltage to maintain a consistent effect across different tissue density. It bases this adjustment on the selected mode, the power setting, and the level of tissue resistance. As tissue resistance increases, the generator outputs constant current followed by constant power followed by constant voltage. The generator controls maximum output voltage to reduce capacitive coupling and video interference and to minimize sparking. It applies this technology to all generator modes except the low 1 (desiccate) coag setting and the two high (fulgurate) coag settings. For details, refer to *Instant Response Algorithm* in this section.

REM Contact Quality Monitoring System

The Force EZ-C Series Electrosurgical Generator uses the Valleylab REM Contact Quality Monitoring System to monitor the quality of electrical contact between the patient return electrode and the patient. The REM system reduces the risk of burns at the return electrode site during monopolar electrosurgery.

When you connect a REM patient return electrode to the Patient Return Electrode receptacle, you activate the REM system. When you activate monopolar output, the generator connects the patient return electrode path. If you activate bipolar output when a return electrode is applied to the patient, the generator automatically deactivates the return electrode circuit to eliminate the possibility of current dispersal.

The REM system continuously measures the resistance at the return electrode site and compares it to a standard range of safe resistance (between 5 and 135 ohms), thus eliminating intermittent false alarms that could result from small changes in resistance. The REM system also adapts to individual patients by measuring the initial contact resistance (baseline resistance) between the patient and the patient return electrode. If the tissue impedance at the return electrode decreases during the surgical procedure, the REM system resets the baseline resistance.

REM Alarm Activation

The REM Alarm indicator flashes red, a tone sounds, and the generator stops producing output power when either of the following occurs:

- The measured resistance is below 5 ohms or above 135 ohms, the limits of the standard range of safe resistance.
- An increase in contact resistance is greater than 40% from the initial measurement (baseline resistance).

The REM alarm indicator remains illuminated red until you correct the condition causing the alarm. Then, the indicator illuminates green and the generator enables RF output.

Electrodes Without the REM Safety Feature

When you use a patient return electrode that does not have the REM safety feature, the REM system does not monitor the patient contact area. It monitors only the pin-to-pin resistance at the connector and can detect broken wires or connectors in the return electrode cord.

The REM indicator does not illuminate green when you connect a patient return electrode without the REM safety feature. Instead, the generator extinguishes the indicator light. If the generator detects a break in continuity between the electrode and the generator, the REM alarm indicator illuminates red.

When resistance between the patient return electrode receptacle pins exceeds 20 ohms, the REM Alarm indicator flashes red, a tone sounds twice, and the generator disables RF output. The REM Alarm indicator remains illuminated red until you correct the condition causing the alarm. Then, the generator extinguishes the red indicator light and enables RF output.

Control Board

Refer to Section 10, *Service Parts*, for components and the *Schematics Supplement* for the board drawing and schematic.

The Control board contains the circuitry that controls the generator, including the indicators and switches on the Display board and the RF output stage on the Power Supply/RF board. Firmware on the Control board performs many diagnostic and initialization routines. It also reports errors as alarm numbers on the front panel. For a complete list of alarm numbers, refer to Section 7, *Responding to System Alarms*.

The Control board interfaces with the Power Supply/RF board through a 96-pin card edge connector. It interfaces with the Display board through a 64-pin ribbon cable.

Microcontrollers

Two microcontrollers on the Control board (the main microcontroller and the feedback microcontroller) work together to control the generator. They communicate with each other through a shared RAM. The main microcontroller (U5) performs all system functions, except the time-critical real time feedback control of generator RF output. The feedback microcontroller (U11), which is a separate, dedicated microcontroller, handles this. All system analog signals are available to these microcontrollers.

A third microcontroller (U9) functions as an application-specific integrated circuit, or ASIC. It generates the RF drive waveforms (T_ON) for the RF output stage.

Main Microcontroller

The main microcontroller (U5) is an 80C562 that incorporates an 8-input multiplexed 8-bit analog-to-digital (A/D) converter. The main microcontroller performs the following activities:

- monitors all dosage error functions and safety circuits
- implements the user interface, including activation control
- communicates with the feedback microcontroller

It is primarily responsible for these functions:

- segment display drivers and LED update
- power control knob, mode buttons, and the activation interface
- serial port interface
- alarm handling
- REM
- audio control
- memory control and storage (system alarms with time stamps, calibration values)
- real-time clock control and interface
- internal self-tests
- dosage error monitoring
- setup mode (for special features)

Main Microcontroller Memory

An ST microelectronics PSD835G2 programmable systems device (U3) provides program memory (512K x 8 external flash memory) and data memory (2K x 8 external battery-backed static RAM) for the main microcontroller. Additional data memory is available from these sources:

- 256 x 8 microcontroller internal RAM
- 4K x 8 external static RAM (U4) shared with the feedback microcontroller
- 128 x 8 external battery-backed static RAM inside the real-time clock (U1)

Battery-Backed RAM

A socket on the Control board contains a 3.0 V lithium button cell battery (BT1) that provides backup power for the 2K x 8 external RAM on the PSD835G2 device (U3) and the 128 x 8 external RAM on the real-time clock (U1) used by the main microcontroller. The battery-backed RAM stores statistical data about generator use, calibration constants, special features settings, and last setup parameters.

Feedback Microcontroller

The feedback microcontroller (U11) is an 80C562. It receives commands from the main microcontroller and, when the generator is activated, establishes the appropriate relay closures and activates RF output. The feedback microcontroller continually adjusts the output signal of the generator by controlling the high voltage DC power supply and the RF clock circuitry. The feedback microcontroller serves the following primary functions:

- scaling relay control and output relay control
- T_ON ASIC waveform control
- leakage control (coag)
- constant voltage, current, and power feedback control
- ECON initialization
- real-time information update (actual voltage, current, power, impedance, Instant Response System)
- memory tests

Feedback Microcontroller Memory

An ST microelectronics PSD835G2 programmable systems device (U6) provides program memory (512K x 8 external flash memory) and data memory (2K x 8 external static RAM) for the feedback microcontroller. Additional data memory is available from these sources:

- 256 x 8 microcontroller internal RAM
- 4K x 8 external static RAM (U4) shared with the main microcontroller

Shared RAM

An IDT 713425A device (U4) with semaphore flags provides the 4K x 8 external shared static RAM. The shared RAM allows the main microcontroller (U5) and the feedback microcontroller (U11) to share common variables. It functions as a communications interface between the main and feedback microcontrollers. It also provides these microcontrollers with additional general purpose RAM.

Real-Time Clock

The real-time clock (U1), a DS12885, tracks the date and time of day and provides 128 bytes of battery-backed RAM. Of the 128 bytes, it uses 14 internal to the chip for the clock and control registers. The main microcontroller uses 114 bytes of general purpose RAM to store calibration constants, special features settings, and last setup parameters.

I/O Expansion

Three devices provide I/O expansion capabilities:

- One ST microelectronics PSD835G2 programmable systems device
- One ST microelectronics PSD835G2 programmable systems device
- 82C55 expansion port (U2)

The ST Microelectronics PSD835G2 incorporates 52 individually programmable I/O pins divided into 6 ports of 8-bits each and 1 port of 4-bits. Of the general I/O pins, 24 can be alternatively utilized for 24 PLD outputs. The PSD835G2 also contains 512K x 8 main flash memory, 32K x 8 boot flash memory, 2K x 8 of SRAM, and a power management unit for battery backup. The power management unit for battery backup is not used by the feedback microcontroller. The I/O expansion capabilities of the feedback PSD835G2 has a built-in IEEE 1149.1 compliant JTAG serial port to allow full-chip in-system programmability (ISP). The main PSD835G2 is #1 on the JTAG chain and the feedback PSD835G2 with the exception that the 512K x 8 flash memory for the main PSD835G2 is accessed in a bank switching methodology and the I/O expansion capabilities are configured as outputs for lamp control, keyboard scanning, and chip selects. The 82C55 is configured as all inputs, and is used to read the keyboard, keying signals, accessory switches, and system status flags.

Keyboard Interface and Activation Inputs

The keyboard interface is a simple row and column matrix between three bank select output lines (BANK0–BANK2) on port A of the PSD835G2 (U3) used by the main microcontroller and eight keyboard (KBD_D0–KBD_D7) input lines on port A of the 82C55 expansion port (U2).

Port B of the 82C55 expansion port reads activation inputs from the IsoBloc decoding circuits on the Power Supply/RF board.

Power Supply Supervisor Circuit

The power supply supervisor circuit (U14), a MAX691, generates a Reset signal and a Reset\ signal for the main microcontroller (U5) if the power supply voltage to the Control board drops below 4.65 V. Reset\ also places the PSD835G2 (U3) and the PSD835G2 (U6) in sleep mode and disables the 2K x 8 external static RAM.

A/D and D/A Conversion

Each 80C562 microcontroller (U5 and U11) contains an 8-channel multiplexed 8-bit A/D converter. Incorporating gain scaling relays in the sense circuits on the Power Supply/RF board and prescaling based on the expected input voltage or current values enhances the resolution of voltage and current sense inputs.

The main microcontroller senses redundant RF output current and voltage from additional sense circuits located on the Power Supply/RF board. The system does not gain scale this information since it is for dosage monitoring only.

An MP7226 quad digital-to-analog (D/A) converter (U15) provides 4-channel 8-bit D/A capabilities for the feedback microcontroller to output 0 to 5 Vdc analog voltages.

Waveform Generation (T_ON ASIC)

A dedicated 89C54 microcontroller (U9) generates the RF waveforms (T_ON\) for the RF output amplifier on the Power Supply/RF board. The microcontroller functions as an application-specific integrated circuit (ASIC) performing an endless series of repetitive tasks while enabled.

The feedback microcontroller (U11) holds the T_ON ASIC (U9) in a reset state until the feedback microcontroller detects a valid activation request. After validating the request, the feedback microcontroller releases the T_ON ASIC from reset and communicates a 4-bit code that represents the generator mode to be activated. Six activation codes are acceptable:

- 0: bipolar
- 2: pure, low 2, and low 3
- 3: blend
- 7: low 1
- 8: high 1
- C: high 2

The Force EZ-C Series Electrosurgical Generator does not use Codes 1, 4, 5, 6, 9,A,B, and D-F.

Each code generates a unique waveform pattern to be delivered to the RF output stage of the generator. The T_ON ASIC reads and evaluates the code and, if the code value is acceptable, repetitively generates the appropriate waveform until the activation request ends. After the request ends, the feedback microcontroller places the T_ON ASIC back into reset.

If the code received by the T_ON ASIC is not valid, the internal program sets an error flag, deactivates all output signals, and remains in an error state until the system is reset.

T_ON Average Check

Hardware integrates the T_ON waveform generator output waveform and returns it to the main microcontroller as an analog value called T_ON average. The T_ON average is different for each distinct output mode of the T_ON waveform generator. The main microcontroller continually checks the T_ON average for compliance with the calibrated value to ensure that the T_ON waveform generator is operating properly.

The T_ON average signal rests at 5 V when the generator is inactive and drops to the calibrated value when activation occurs. The main microcontroller checks to make sure the T_ON average signal is within ± 15 counts of the calibrated value.

During spark control in the cut modes or wak control in the coag modes, the T_ON average rises an indeterminate amount. Due to this unknown, the system allows the T_ON average to rise to 253 counts, which guarantees the T_ON waveform generator is still operating. It still does not allow The T_ON average to drop below the lower limit of 15 counts mentioned above.

Audio Alarm

The audio alarm circuit resides on the Power Supply/RF board. Software and hardware control the audio alarm:

- The UP_TONE\ and LO_TONE signals generated by the main microcontroller in response to activation inputs, alarms, and power-up provide software control.
- The RF_TONE\ signal generated in the RF output stage by RF sensing circuitry on the Power Supply/RF board provides hardware control.

Serial Interface

The RS-232 serial port is a software-pollled interface to the main microcontroller (U5). It provides diagnostics and calibration to an external device (for example, a computer) connected to the port. Transmission and receipt of command strings do not stop real time processing, except as single characters are read from or written to the serial port. The serial port configuration is the following:

- 9600 baud
- 8 data bits,
- 1 stop bit
- no parity

The system derives this timing from the main microcontroller oscillator frequency of 11.0592 MHz.

The Control board serial port signals connect to the Power Supply/RF board through the 96-pin connector. The signals then connect to the 9-pin serial port connector on the Power Supply/RF board.

Dosage Error Algorithm

The basis for the dosage error algorithm for the closed loop modes (bipolar, cut, and the low 2 and low 3 settings) is a comparison between two microcontroller/sensor sets:

- backup current and voltage sensors, read by the main microcontroller (U5)
- primary current and voltage sensors, read by the feedback microcontroller (U11)

Each microcontroller monitors one set of sensors and calculates real-time output current, voltage, and power. While the feedback microcontroller operates the generator, the main microcontroller checks the values to make sure the main and feedback microcontroller calculations agree.

In a closed loop mode, there is a 500 ms delay before the dosage error algorithm monitors the rms output of the generator. After the delay, the algorithm first checks to see that the voltage and current calculated by the backup sensors are less than 125% of the value calculated by the primary sensors. On passing this test, the algorithm checks the feedback mode of the generator:

- In current control mode, the current calculated by the backup sensors should not deviate from the current calculated by the primary sensors by more than 50% of the value calculated by the primary sensors.
- In power control mode, the power calculated by the backup sensors should not be greater than 125% of the value calculated by the primary sensors.
- In voltage control mode, the voltage calculated by the backup sensors should not deviate from the voltage calculated by the primary sensors by more than 50% of the value calculated by the primary sensors.

During closed loop activation, the main microcontroller continually checks for broken backup sensors. It compares the current and voltage sensor analog values to the previous readings to ensure that the sensor values are not constant or falling while ECON is rising.

The basis for the dosage error algorithm for the open loop modes (the low 1, high 1, and high 2 settings) is the ECON calculated for the mode. The main microcontroller calculates an ECON that represents 125% of the front panel power setting and verifies that SYS_ECON and HV_SEN do not exceed this value while the generator is activated.

These tests detect power output while not activated, stuck or aberrant sensors, and improperly delivered power. The dosage error firmware executes in less than one second.

Instant Response Algorithm

The Force EZ-C Series Electrosurgical Generator's Instant Response system is a closed loop control algorithm implemented in microcontroller firmware. The system applies it to some settings, but not others:

- Applied to
 - bipolar
 - monopolar cut modes
 - low 2 coag
 - low 3 coag
- Not applied to
 - low 1
 - high 1
 - high 2 coag

As tissue impedance increases from short circuit to open circuit, the algorithm implements first constant current, then constant power, and finally, constant voltage. Controlling the maximum output voltage reduces capacitive coupling, reduces video interference, and eliminates sparking. At low impedances, constant current protects output circuitry. At high impedances, constant voltage control limits arcing and electromagnetic interference (EMI).

Constant Current

The algorithm holds output current constant according to this equation:

$$I = (P/R)^{(1/2)}$$

where I is the output current, P is the power set by the user, and R is the constant current to constant power impedance switchpoint.

Constant Power

The algorithm maintains the power set by the user.

Constant Voltage

The algorithm controls the output voltage according to the following equation:

$$V = (P*R)^{(1/2)}$$

where V is the output voltage, P is the power set by the user, and R is the constant power to constant voltage impedance switchpoint.

High Impedance Instant Response Operation

The firmware algorithm clamps the output voltage to specific levels for high impedance conditions. The clamp level is a function of the active mode. This helps prevent arcing and electromagnetic interference (EMI).

Analog to Digital Saturation

If the analog to digital converter is saturated, the Instant Response feedback loop reduces the output voltage to allow an unsaturated operating condition. The feedback loop switches the control function to maintain the analog to digital converter in the linear operating range.

Display Board

Refer to the *Schematics Supplement* for the schematic.

The Display board resides in the front panel assembly. It contains several types of display:

- LED displays
- seven-segment power setting displays
- RF indicator lamps

The Display board switch circuitry includes the following components:

- mode selection switches
- encoders for changing power settings
- REM switch circuit
- footswitch decoding circuit for the front panel Footswitch receptacle

Bipolar, Cut, and Coag Power Setting Encoders

Three mechanical encoders (S1, S3, and S6) change the current power settings for bipolar (S1), cut (S3), and coag (S6). The encoders effectively contain two switches that open and close as the knob turns, either shorting the encoder output to DGND or allowing pull-up resistors on the Control board to pull the encoder output high. The switches open and close 90 degrees out of phase. The system determines the knob's turning direction by determining which switch is leading the other. The result seen by the main microcontroller is a 2-bit binary code in which only one bit changes for each state change. When the knob turns clockwise, the switches cycle through states 00, 10, 11, 01, 00, etc; counterclockwise, the cycle reverses (00, 01, 11, 10, 00, etc).

RF Indicator Lamps

The RF indicator lamps illuminate during RF activation to indicate the presence of RF power. Four incandescent bulbs (LP1–LP12) illuminate each of the three indicator bars (bipolar, cut, and coag) on the front panel:

- LP1–LP4 illuminate the bipolar bar, changing its color from white to blue to indicate bipolar activation.
- LP5–LP8 illuminate the yellow bar, indicating cut activation.
- LP9–LP12 illuminate the blue bar, indicating coag activation.

Field effect transistors (FETs) Q1, Q4, and Q5 turn the RF indicator lamps on and off. Resistors R2, R3, R4, R10, R39, R40, R42, R44, R49, R50, R52, and R54 set the amount of current flowing through the lamps when they are turned on. The value of these resistors varies for each indicator bar, depending on the color of the bar, to make the different colors of the bars illuminate with equal intensities. Pull-down resistors R1, R47, and R48 attach to gates Q1, Q4, and Q5 to reduce the input impedance of Q1, Q4, and Q5 as seen by the main microcontroller on the Control board. This rounds off the edges of these digital signals, reducing high frequency emissions. The lowered impedance also reduces the susceptibility of the circuit to noise from other circuits.

LED and Seven-Segment Display Drivers

This circuit contains two display drivers: the LEDs and the seven-segment displays. The LEDs indicate modes of operation, REM condition, and the selected footswitch mode. The seven-segment displays indicate bipolar, cut, and coag power settings.

Each display driver (U5 and U6) can drive up to eight banks of eight LEDs by multiplexing the time that it turns each bank on. Wiring the banks together increases the time that a group of LEDs can remain on, effectively increasing the brightness of that group.

U6 drives the discrete LEDs. These include green indicators for several displays:

- cut modes (pure and blend)
- coag modes (low and high)
- bipolar and accessory footswitch arrow indicators
- eight red/green bicolor LEDs for the REM indicator

The anode of the mode and footswitch selection LEDs (D1–D6) connect to driver U6, pin 16 (digit 2) and pin 23 (digit 3). Using pairs of the driver digit lines makes the effective duty ratio for these LEDs 1/4:

- The red anodes of the REM LEDs connect to U6, pins 17 and 20 (digits 4 and 5) for a 1/4 duty cycle.
- The green anodes of the REM LEDs connect to U6, pins 18, 21, and 22 (digits 6-8) for a 3/8 duty cycle.

U5 drives the seven-segment displays that indicate power settings:

- DS1 and DS2 indicate the bipolar power setting
- DS3–DS5 indicate the cut power setting
- DS6–DS8 indicate the coag power setting.

The anodes of these displays each connect to only one digit line of the driver. The effective duty cycle is 1/8 for each seven-segment display.

Some filtering components are associated with U5 and U6. Bypass capacitors C19, C20, C21, and C22 connect between + 5V and DGND. C19 and C21 have a relatively small capacitance value of 0.1 μ F to filter higher frequency noise. C20 and C22 have a relatively large capacitance value of 47 μ F to supply the large spikes of current for the LEDs. The multiplexing action of the drivers, which typically occurs at 250 Hz, generates the large current spikes.

Resistors R18, R20, R22, R24, R26, R28, R30, R32, R34, R36, and R38 reduce the input impedance of the display driver inputs as seen by the main microcontroller on the Control board. This rounds off the edges of these digital signals, reducing high frequency emissions. The lowered impedance also reduces the susceptibility of the circuit to noise from other circuits.

Mode Selection Switches

The mode selection switch circuitry uses five discrete switches (S2, S4, S5, S7, and S8). S2 toggles the front panel footswitch control between bipolar output or single-pin accessory output. S4 and S5 select the pure and blend cut modes. S7 and S8 select the low or high coag modes.

FETs Q2, Q3, and Q6 select a bank of switches for the main microcontroller to read. When one of the digital signals (BANK0–BANK2) is high, the corresponding FET pulls its output low allowing the main microcontroller to read any switch closure in that bank as a logic low. If a switch is not pressed, a pull-up resistor on the Control board pulls the corresponding output (KBD_D6 or KBD_D7) high and the main microcontroller reads it as a logic high. Resistors R16, R43, and R53 pull the outputs of Q2, Q3, and Q6 high when they are off. Pull-up resistors R15, R41, and R51 attach to gates Q2, Q3, and Q6 to reduce the input impedance as seen by the main microcontroller on the Control board. This rounds off the edges of these digital signals, reducing high frequency emissions. The lowered impedance also reduces the susceptibility of the circuit to noise from other circuits.

Schottky diodes (Z1–Z5) prevent false switch readings if someone presses multiple switches. For example, when S4, S5, and S7 are all closed and the BANK2 signal is high, Q6 pulls KBD_D6 low through S7. If Z2 is not placed in line with S4, the output of Q3 is pulled low through S4, and KBD_D7 is pulled low through S5. To the main microcontroller, S7 and S8 appear to be pressed; however, since S8 is not pressed, this reading is false. Schottky diodes are used because the logic low level placed on KBD_D6 or KBD_D7 must be below 0.8 volts to be read correctly.

REM Switch Circuit

The REM switch circuit detects the presence of a REM patient return electrode plugged into the Patient Return Electrode receptacle. The center plastic pin on the REM plug moves a mechanical lever in the receptacle, allowing it to sense the plug and open S9. This allows R55 to pull REM_SW high, telling the main microcontroller that a REM patient return electrode is connected to the generator.

When you use an electrode without the REM safety feature, S9 remains closed and REM_SW is pulled low. Capacitor C23 filters noise on REM_SW. Resistor R56 limits the amount of current that flows through S9 when it closes and C23 discharges.

Front Panel Footswitch Circuit

The footswitch circuit on the Display board provides a means of activating the selected receptacle: the Bipolar Instrument receptacle or the single-pin Accessory Instrument receptacle. This circuit consists of a footswitch receptacle, an isolated DC/DC converter, two optoisolators, and associated circuitry.

The footswitch connector (P1) provides the connecting point for the footswitch. The common mode choke (L1) and capacitors (C1–C3, C16–C18, and C24–C26) provide filtering that blocks high frequency noise from exiting the generator on the footswitch cable. Note that C16–C18 decouple the footswitch outputs to DGND and then C1–C3 and C24–C26 decouple DGND to CHGND. This occurs in two stages in order to use the DGND plane on the board as a low impedance path from the footswitch circuit to the edge of the board, where it is easier to connect to chassis ground.

- Pressing a footswitch coag pedal allows, +V_ISO_5_FIL, pulling MON1_COAG low through U1, to pull the corresponding signal (FRONT_FSW_COAG_FIL) high.
- Pressing a footswitch cut pedal allows +V_ISO_5_FIL, pulling MON1_CUT low through U2, to pull the corresponding signal (FRONT_FSW_CUT_FIL) high.

Resistors R5 and R6 set the amount of current flowing through optoisolators U1 and U2. An isolated DC/DC converter (U3) provides the power source for the footswitch circuit via isolated power (+V_ISO_5) and ground (ISO5). Capacitors C6, C10, and C15 provide high frequency filtering to reduce emissions. Capacitor C12 supplies a source for current spikes flowing into the switching input of U3.

Footswitch Board

Refer to Section 10, *Service Parts*, for components and the *Schematics Supplement* for the board drawing and schematic.

The Footswitch board contains circuitry for the footswitch connectors on the rear panel, a speaker, and the volume control potentiometer for the audio circuit. The board interfaces to the Power Supply/RF board.

The monopolar footswitch connector (J1) provides footswitching capability for the multipin Monopolar Instrument receptacle located on the front panel. Use only a Valleylab footswitch with the Force EZ-C Series Electrosurgical Generator. Use of an incompatible footswitch may cause unexpected output. The bipolar footswitch connector (J4) provides footswitching capability for the Bipolar Instrument receptacle located on the front panel. Capacitors C1–C5 provide filtering that blocks high frequency noise from exiting the generator on the footswitch cables.

The audio circuit on the Power Supply/RF board uses the speaker (SP1) on the Footswitch board to enunciate the presence of RF output and to provide an auditory indication of alarm conditions. The potentiometer (R1) adjusts the volume of RF output activation tones. You cannot turn the speaker volume entirely off. You also cannot adjust the volume used during alarm conditions.

Power Supply/RF Board

Refer to Section 10, *Service Parts*, for components and the *Schematics Supplement* for the board drawing and schematics.

The Power Supply/RF board is the main board of the generator. It contains the high voltage power supply and the RF output stage. Circuitry on this board performs several functions:

- output voltage monitoring (spark control circuit)
- leakage current sensing (RF leakage sensing and reduction circuits)
- REM impedance monitoring (REM circuit)
- switch closure detection (IsoBloc circuit)
- RS-232 connector detection
- EKG contact closure connector detection
- rear panel footswitch control (footswitch decode circuit)
- audio tone generation (audio circuit)
- thermal monitoring (temperature sense circuit) power

Power Supply/RF Board Interfaces

The Power Supply/RF board interfaces to other boards and generator components:

- Control board
- Footswitch board
- heat sink components (RF damping resistors and the RF MOSFET)
- a series of single wire attachment points for connecting the sense transformers
- low voltage power supply (AC input and output)

A series of fuse clips connect the RF outputs and other front panel interfaces (i.e., REM and handswitching signals). The fuse clips mate to lugs located in the output portion of the front panel assembly.

High Voltage Power Supply

Warning

Potentially lethal AC and DC voltages are present in the AC line circuitry, high voltage DC circuitry, and associated mounting and heat sink hardware described in this manual. They are not isolated from the AC line. Take appropriate precautions when testing and troubleshooting this area of the generator.

The high voltage power supply contains several circuits:

- the power entry circuitry
- auto mains switching circuitry
- AC/DC conversion circuitry
- a DC/DC switching regulator

Power Entry Circuit

The power entry circuit consists of several items:

- an integral three-wire power cord receptacle
- a fuse drawer
- an EMI filter
- a separate power switch

The receptacle/filter reside on the rear panel of the generator; the power switch, on the front panel. AC line fuses are changeable from the rear of the generator.

Auto Mains Switching Circuitry

The auto mains switching circuit detects the AC line voltage level and controls the triac (D3). This triac controls the topology of the AC/DC converter. For 110 to 120 Vac operation, the triac is on, which connects the AC neutral to the center of the AC/DC converter capacitor bank (C58–C61). In this configuration, the circuit acts as a doubler using the right hand half of the bridge rectifier (CR80). For 220 to 240 Vac operation the triac is off and CR80 becomes a full wave rectifier.

The control IC (U10) functions as follows:

- The series circuit (CR6, R59, R64, and C57) provides power for U10.
- Pin 1 (Vss), a shunt regulator, provides a –9 V (nominal) output.
- The divider (R65 and R66) measures the input line voltage. Since the voltage at pin 8 varies with the line, it can sense the line voltage zero crossing as well as the peak voltage.
- Pins 2 and 3 are inputs to an oscillator used for triac triggering timing.
- R67 and C50 set the oscillator frequency.
- Pin 7 connects to Vss, which places the circuit in the fail-safe mode. Thus, once the circuit enters full bridge mode it remains in that mode until input power recycles. A power dropout cannot cause the circuit to accidentally act as a doubler when the higher input voltage range is in use.

AC/DC Converter

The AC/DC converter uses CR80 as either a doubler or full wave rectifier, depending on the input voltage. In either case, it provides an unregulated nominal 300 Vdc to the DC/DC switching regulator. Thermistors R68 and R70 provide inrush current limiting, and fuse F1 provides protection against faults in the DC/DC switcher.

Capacitors C58–C61 function as an energy storage reservoir for the DC/DC switcher. C70 is a high frequency bypass filter. Bleeder resistors R69 and R71 discharge the capacitors when you disconnect the AC line or turn the power switch off.

DC/DC Switching Regulator

The DC/DC switching regulator is a buck-derived, pulse width modulated (PWM) transformer. It is an isolated, fixed frequency, full bridge converter. The system uses PWM IC (U3) in the voltage mode. The output of the regulator is adjustable from approximately zero (0) to 180 Vdc.

The full bridge consists of four power MOSFETs (Q2, Q4, Q5, and Q7) that operate at AC line potential. Transistors Q2 and Q5 are on while Q4 and Q7 are off, and the reverse, making power signals to the power transformer bidirectional, or push-pull. This allows full use of the transformer core magnetization capability. Regulation results from modulating the time that each MOSFET pair is on. Capacitor C67, in series with the power transformer T3 primary, prevents DC flux imbalance. A snubber circuit (C66 and R79) absorbs leakage energy spikes. Another snubber circuit (C91 and R121) reduces spikes due to reverse recovery of the output bridge rectifier.

Important

T1 consists of two transformers electrically and magnetically isolated from each other but assembled into the same package. T1A and T1B form one transformer; T1C and T1D form the other.

Transformer T1 transformer-couples the gate driver circuitry for each MOSFET to provide AC line isolation. It consists of a dual MOSFET driver (U1) and various damping resistors. Resistors R40, R58, R63, and R78 minimize turn-off oscillations. Resistors R17 and R41 damp ringing due to parasitic inductances in T1. Blocking capacitors C12 and C26 prevent DC flux imbalance in T1.

A high voltage diode bridge (CR17, CR22, CR23, and CR36) provides full wave rectification for the output of the power transformer. L1, C89, and C108 filter the rectified power signal. The regulated DC output from this supply is the input to the RF stage of the generator.

The SYS_ECON signal from the microcontroller controls the output voltage level. This 0 to 5 Vdc signal sets the reference for the PWM control loop. An external op-amp (U4A) provides gain and integration, since common mode voltage limitations in U3's internal op-amp preclude its use over the full range of 0 to 5 V. The internal op-amp is connected as a follower. SYS_ECON is compared to the feedback voltage from the output divider (R21 and R22) and an error signal (ECON) is sent to the PWM microcontroller. In addition to the error signal, U4A and the associated R-C networks provide lead-lag loop compensation to increase the bandwidth of the regulator beyond that of the output L-C filter.

The output of U3 is a pair of 180° out-of-phase signals: comparing ECON with the internal oscillator ramp waveform modulates the signals' pulse width. At the start of an oscillator cycle, U3 turns on an output, turning it off when the ramp voltage crosses the ECON level. The two output signals from U3 (pins 11 and 14) feed the MOSFET drivers (U1A and U1B).

R42 and C27 set the U3 oscillator frequency. C29 controls the ramp-up of the pulse width at power on for slow start control. Transformer T2 limits the power transformer primary current, protecting against faults in the DC/DC switcher power stage and faults in circuitry downstream of the switcher. CR2–CR5 rectify, and R47 and C30 filter, the secondary current of T2, which then goes to the current limit pin (pin 9 of U3). During an overcurrent condition the U3 current limit function resets the slow start circuit, resulting in the output cycling from on to off until the current falls. Pin 9 of U3 also allows remote shutdown of the DC/DC switcher through Q1 and CR1. The shut down signal comes from the main microcontroller on the Control board.

The resistor divider formed by R88 and R89 provides dosage error sensing.

Low Voltage Power Supply

The low voltage power supply, rated for 40 watts, delivers a regulated +5 Vdc and ± 12 Vdc output. This power supply has a universal input and works for both input voltage ranges. It has internal current limiting, overvoltage, and thermal shutdown protection. The low voltage power supply connects to the Power Supply/RF board through four pins:

PIN	Voltage
1	+5 Vdc
2	-12 Vdc
3	+12 Vdc
4	Ground

The significant specifications of the low voltage power supply compared to estimated loads are the following:

Output Voltage	Output Current	Output Power	Estimated Load
+5 Vdc	4000 mA	20.0 W	1000 mA
-12 Vdc	400 mA	4.8 W	160 mA
+12 Vdc	2000 mA	24.0 W	1400 mA

RF Output Stage

Warning

High frequency, high voltage signals that can cause severe burns are present in the RF output stage and in the associated mounting and heat sink hardware described in this manual. Take appropriate precautions when testing and troubleshooting this area of the generator.

The RF stage consists of the following components:

- a single MOSFET power switch with associated gate drive circuitry
- an RF power transformer
- tuning capacitors
- an RF output L-C filter
- output directing relays
- topology selecting relays
- RF voltage and current sense circuits
- a switched damping network for certain operational modes

The MOSFET gets its gating signal from the T_ON ASIC (U9) on the Control board. The T_ON ASIC also provides the gating signal for the switched damping network.

The topology selecting relays (K1 and K15) set the RF stage in the following modes:

unenergized	energized
RF stage is in the coag mode	RF stage is in the cut and bipolar mode.

Note that cut modes include the low 2 and low 3 settings from the topology standpoint.

Primary Sense Circuits

The primary voltage and current sense circuits provide feedback information to the feedback microcontroller in the bipolar and cut modes.

For voltage sensing, the two 10 k ohm resistors in series with the primary of T12 work in concert with the 100 ohm resistor across the secondary to divide the output voltage down to a manageable level. Depending on the front panel power setting, one of three relays (K2–K4) switches in to give optimum scaling. The four op-amps (U18 and U23), along with the associated resistors, capacitors, and diodes, form a precision full wave rectifier circuit. U23B is a high input impedance follower to prevent the rectifier circuit from loading down the resistive divider. U23A is a follower that adds phase delay, which improves balance in the rectified waveform between positive and negative half cycles of the input signal. U18A and U18B perform the actual rectification. The R-C filter after the last op-amp converts the rectified waveform to DC, with the full scale at 5 Vdc.

The current sense circuit, which uses current transformers T5 and T6, works the same as the voltage sense circuit. T6 senses bipolar current and T5 senses monopolar current. Relay K9 selects the appropriate current. Note that the current scaling relays (K5–K7) switch at different power settings than the voltage scaling relays.

Redundant Sense Circuits

The primary sense circuits are functionally in parallel to redundant sense circuits for the dosage error monitoring function performed by the main microcontroller on the Control board.

For redundant voltage sensing, a current sense transformer (T8) connects in series with the capacitor ladder. A bridge rectifier (CR24, CR25, CR27, and CR28) rectifies, divides, and limits this voltage before op-amp circuit U31A filters and buffers it.

For redundant current sensing, another current sense transformer (T7) senses current flow in both the bipolar output leads and the monopolar output leads. A circuit identical to the redundant voltage sensing circuit follows for rectification, division, limiting, buffering, and filtering.

The signals produced from the redundant sense circuits are scaled for zero to 5 Vdc operation for use by the analog-to-digital channels of the main microcontroller on the Control board.

Output Relays

In all monopolar modes, K12 is closed and routes patient return current through the REM receptacle. K10 routes active current through the single-pin (footswitch activated) Accessory Instrument receptacle. K11 routes the active current through the multipin (handswitch or footswitch activated) Monopolar Instrument receptacle.

In bipolar mode, the REM receptacle relay is open. Relays K13 and K14 route bipolar current to the Bipolar Instrument receptacle.

All output relays are open when the generator is not being activated.

Bipolar Mode

The bipolar mode circuit topology is essentially the same as the cut modes, except the output voltage flows from C159 and the switching frequency is 470 kHz. These differences allow the higher currents and lower voltages required in bipolar surgery while still maintaining the advantages of zero voltage switching in the MOSFET. The T_ON\ signal is a continuous pulse train.

Cut Modes

In the cut modes, the K1 setting allows the following conditions:

- diode CR7 is in parallel with the MOSFET body drain diode
- C62 and C65 are across the MOSFET
- the transformer primary consists of windings 1-2 and 3-4 in series

K15 is closed so the series capacitor bank (C143, C154, C159, C165, and C166) is across the output.

In the pure cut mode, the T_ON\ signal is a continuous pulse train with a frequency of 393 kHz. In this case, essentially two resonant circuits operate in tandem. The output L-C filter is tuned just slightly higher than the RF switching frequency, achieving a high degree of filtering. The output is very sinusoidal over the full range of load impedances. Capacitors C62 and C65 are tuned with the RF transformer primary so that the flyback voltage appearing across the MOSFET at turn off is a half sine pulse and returns to zero volts before the next cycle begins. The T_ON\ pulse width is chosen to support this tuning. This zero voltage switching improves the efficiency of the RF stage and is effective over a wide range of load impedances.

The circuit topology of the blend cut mode is the same as the pure cut mode. In blend mode, however, the T_ON\ signal is an interrupted pulse train with a 50% duty cycle and a frequency of 27.1 kHz. For a given power setting, blend gives a higher peak current, providing better hemostasis than pure. To minimize ringing at the beginning of the off period of the blend waveform envelope, the damping resistor switches on just before switching ends and stays on for part of the off period.

Coag Modes

In the high 1 (fulgurate) setting, the K1 setting allows these conditions:

- diode CR7 blocks reverse current in the power MOSFET
- C100 as well as C62 and C65 are across the MOSFET
- the transformer primary consists of winding 1-2 only

K15 is open, keeping the series capacitor bank (C143, C154, C159, C165, and C166) out of the circuit.

The T_ON\ signal is a continuous pulse train with a pulse width of 1.69 μ s and a frequency of 57 kHz. When the MOSFET turns on, some energy goes to the output and some goes to storage in the T4 core. When the MOSFET turns off, the energy stored in the core rings out with a nominal frequency of 470 kHz. C62, C65, C100 and the inductance of winding 1-2 of T4 set the frequency. CR7 blocks reverse current in the body drain diode of the MOSFET so that the power waveform can ring negative. This allows high peak voltages at the output. In most cases, the system delivers all the energy stored in the transformer core during one switching cycle to the load before the next cycle begins.

To minimize ringing on the output voltage waveform at light loads, transistor Q8 switches in the 50 watt, 50 ohm heat sink mounted resistor in series with the transformer primary for part of the RF switching cycle.

The high 2 (fulgurate) setting works the same as the high 1 (fulgurate) setting, except the T_ON\signal is a continuous pulse train with a pulse width of 1.69 μ s and a frequency of 30 kHz.

In the low 1 coag setting, the K1 setting allows these conditions:

- diode CR7 is in parallel with the MOSFET body drain diode (like the cut modes)
- K15 is open

The T_ON\ signal is a continuous pulse train with a pulse width of 2 μ s and a frequency of 39 kHz. The output resonates with a nominal frequency of 290 KHz.

The microcontroller treats the low 2 and low 3 coag settings as feedback controlled cut modes. Its operation is the same as pure cut described above, except the power curve is different.

Spark Control Circuit

The spark control circuit uses the voltage sense circuit to monitor the output voltage. It interrupts the delivery of power if the output voltage exceeds a preset threshold. This greatly reduces sparking when removing an activated accessory from tissue. The sparking occurs because the RF stage tuning results in a higher natural gain at light loads than at heavy loads. Thus, during sudden transitions from heavy to light loads, the output voltage rises faster than the microcontroller can respond. This analog circuit works outside the microcontroller loop at a much greater speed.

The rectified but unfiltered waveform from the output voltage sense circuit goes into a peak detector (U13A, CR8, and C76). This input signal is called VSEN_SCC. A high impedance buffer (U13B) maintains the integrity of the peak detected signal. The output of this buffer divides and goes to a comparator. The other input to the comparator is an analog threshold level (VMAX_CLP) that the feedback microcontroller on the Control board sets: This input depends on the mode and power setting.

When the peak detected sample of the output voltage exceeds the threshold, the condition fires one-shot U15A, which generates a 3 ms pulse (SPARK_CON) that goes to the T_ON ASIC on the Control board. the T_ON ASIC ignores this pulse if it occurs during the first 0.2 seconds of activation. Otherwise, SPARK_CON causes the T_ON\ signal to stop. The feedback microcontroller on the Control board senses this and realizes that the circuit has suppressed a spark. The feedback microcontroller waits either 10 ms in low 2 or low 3 coag or 100 ms in pure cut, then re-initiates T_ON\ with a frequency of 470 kHz. The frequency returns to 393 kHz after one second of continuous activation or when the generator is reactivated.

RF Leakage Sensing and Reduction Circuit

For the high (fulgurate) settings, the pulse repetition period for high voltage RF output varies with changes in spark and patient tissue impedance to limit the RF leakage current to a desired level. The divider (R90, R94) located on the primary side of T4 produces the VSENSE signal. VSENSE goes to a negative peak detector (U20A) that generates the analog signal (VPEAK-). Then U21A amplifies and inverts the signal.

The averaged signal (now called VPK+) goes to the feedback microcontroller on the Control board, which adds it to the ECON value at the selected power setting. The sum of these signals, with the proper gain factors, varies linearly with load impedance at the patient site. This sum enters into a pulse width modulator (also part of U11) on the Control board, which sends its output (WAK) to the NAND gate (U10) on the Control board. This action inhibits the T_ON signal for up to four consecutive cycles.

REM Circuit

The REM transformer (T10) provides isolated reflected impedance sensing for tissue impedance across the REM patient return electrode terminals (connected to J17 and J19). In addition to tuning the REM circuit, capacitors C149–C151 and C157 provide a return path for high frequency RF signals to the RF output transformer.

The REM transformer (T10) and capacitors C149–C151 and C157 form a resonant circuit with a nominal operating frequency of 80 kHz. This frequency is positioned between RF output harmonics to prevent electrosurgical RF noise from corrupting the impedance measurement. The resonant characteristics of the REM circuit are similar to those of a band pass filter. This arrangement heavily attenuates spectral components outside the 80 kHz pass band while allowing the 80 kHz components to pass. When the resonant circuit is perfectly tuned, the primary voltage and current are exactly in phase.

REM Oscillator

The REM oscillator is a stable adjustable ceramic oscillator. R125, a temperature dependent resistor, provides temperature compensation. The REM_CLK signal from driver U29A actually provides the REM current to the REM transformer (T10). The REM_DRV signal is an inverted version of this signal that correctly times the REM voltage sensing. The main microcontroller on the Control board uses digital potentiometer U26 to calibrate the REM circuit during calibration.

IsoBloc Circuit

The IsoBloc circuit provides a means of detecting a switch closure in an output accessory while maintaining electrical isolation between the generator output and ground referenced circuitry. The IsoBloc circuit consists of an isolated DC power supply and an optoisolator link from the output connected circuitry to the ground referenced low voltage circuitry. Each handswitching output of the generator (multipin monopolar and bipolar) is associated with its own IsoBloc power source and isolated signal paths.

Oscillator

The oscillator circuit consists of a 74HCT4060 oscillator/divider (U30) using a 5 MHz ceramic resonator as the frequency determining element. The output of the oscillator connects internally to the input of a counter/divider chain. The Q6 output of the divider yields a 78.13 kHz square wave, applying it to the input of two 4081 AND gates (U27A and U34A) for buffering and gating with the ISO_TST\ signal. The software system uses the ISO_TST\ signal to shut off the IsoBloc supplies for safety testing.

Power Supply

The two 4081 AND gates drive two VN10KM FETs (Q9 and Q10) that connect to transformers T9 and T11. The system operates the transformers in a flyback mode with their associated 6800 pF capacitors (C133 and C139). The voltages at the secondaries of the two transformers, half-wave rectified and referenced to two separate isolated grounds, provide -8 V for operating the isolated activation circuitry.

Optoisolators

The isolated power supply voltages produced by the IsoBloc power supplies connect to the Active output terminals of the generator (J15, J22, and J24). Sensing Active-to-Cut or Active-to-Coag switch closure in a handswitching accessory accomplishes handswitch activation. Current limiting resistors, in series with LEDs in the optoisolators, cause the LEDs to light to a controlled degree while not excessively loading the IsoBloc power supply. The photo-transistor in the optoisolator detects this light. The photo-transistor, which connects to an input to an 82C55 expansion port in the main microcontroller circuit, turns on, pulling the associated input low. The software interprets this as an activation request, and activates the generator after using ISO_TST\ to verify the validity of the activation request.

Audio Circuit

The audio system enunciates the presence of RF output and provides an auditory indication of alarm conditions. This system consists of the following components:

- an audio oscillator
- tone control signals
- a volume control potentiometer
- an audio amplifier
- a speaker

Pulling UP_TONE\ (from the Control board) or RF_TONE\ (from the Power Supply/RF board) low enables the audio oscillator. Diodes D1 and D2 provide a wired-OR function for the two signals. Since UP_TONE\ and RF_TONE\ are +5 V (logic level) signals, resistors R24 and R49 divide the +12 V audio power supply down to about 4.85 V to prevent D1 and D2 from sourcing current into their logic level drive signals. R25 and C31 provide filtering for the resultant wired-OR output.

Enabling either UP_TONE\ or RF_TONE\ low pulls the voltage at the noninverting input of U5B below the Vref threshold present at U5B's inverting input. This condition turns the output transistor of U5B (open collector) on, grounding R31 and allowing U6A to oscillate. Vref, used throughout the audio circuit, results from dividing the +12 V power supply down to about 2 volts through R50 and R54 while C33 provides low pass filtering for Vref.

U6A is a relaxation oscillator: The RC time constants of R29, C11, and C42 determine its frequencies. This design allows the oscillator to produce two distinct frequencies that the state of the LO_TONE signal can select.

- With LO_TONE asserted (+5 V), the voltage at the inverting input of U5A exceeds the 2 volt Vref signal at its noninverting input, thus turning on its output transistor. This effectively connects C11 in parallel with C42 to produce a higher RC time constant for the oscillator, which results in a lower audio frequency.
- Conversely, with LO_TONE not asserted, the output transistor of U5A (open collector) floats, thus removing C11 from the circuit.

The ALARM signal from the Control board selects the user-controlled audio volume or the fixed alarm level volume. U5C and U5D are configured in an exclusive OR arrangement in which the state of the output transistor of U5C or U5D is complementary. In other words, the output transistor of one of these two devices is always on, but both cannot be on simultaneously. Under normal operating conditions, the ALARM signal is low, allowing the U5C output to float while the U5D output transistor is turned on. The output of U5D creates a voltage divider through R1 (the volume control potentiometer on the Footswitch board), R27, and R28 to attenuate the audio signal to levels acceptable for input to the audio amplifier. R27 determines the minimum audio volume. R55 provides an alternate audio signal path in the event of an open volume potentiometer.

When the ALARM signal is high, the U5C output transistor is on while the output of U5D floats. When the U5C output transistor is on, the system pulls R26 to ground, creating a fixed voltage divider with R28 to produce the alarm volume level at the input to audio amplifier U8.

Meanwhile, the output of U5D floats, removing the variable resistor divider from the circuit. In this case, the volume control potentiometer becomes a small resistance in series with the high impedance input from the audio amplifier, negating the effect of the volume setting.

Audio amplifier U8 and speaker SP1 (on the Footswitch board) comprise the final stage in the audio system. AC coupling the audio signal to the amplifier by C43 eliminates the need for well controlled input biasing. Floating its gain select pins sets the U8 voltage gain to about 20. Because the U8 output signal is internally biased to $V_{cc}/2$, it is necessary to AC couple the speaker through C51 to prevent the amplifier from DC biasing the speaker.

The LO_TONE signal drives Q3 to change the gain of U8 to compensate (equalize) the volume for low frequency operation. This is necessary because the speaker (SP1) does not have flat frequency response between the cut tone and the coag tone.

Footswitch Decode Circuit

The Footswitch board resides inside the rear panel of the Force EZ-C Series Electrosurgical Generator. The 3-pin Bipolar Footswitch receptacle (J4) and the 4-pin Monopolar Footswitch receptacle (J1), mounted on the board, extend through the rear panel. The footswitch decode circuit resides on the Power Supply/RF board.

Footswitch activation causes current to flow through the LED section of an optical isolator (ISO1, ISO2, and ISO3). This current generates an IR beam that causes the corresponding photo-transistor to conduct. The signals from the collectors of the transistors go to the microcontroller where they activate the desired mode of operation.

As required by the IEC, the footswitch circuit is isolated from patient connected circuits and able to withstand a potential of 500 Vrms (50/60 Hz). To obtain this isolation, the footswitch side of the circuitry receives power from an isolated power supply (U11). The isolated power supply, an HPR-107, operates from the ground referenced +12 V supply on the Power Supply/RF board. Its output is an isolated 12 volts called +V_ISO_4.

The Control board fault tests this circuit using the ISO_TST\ signal. The main microcontroller asserts ISO_TST to shut down U11 and discharge +V_ISO_4. Using comparators U7A, U7B, and U9A to gate Vref2 allows loopback testing of the footswitch activation circuits.

Temperature Sense Circuit

Since the Force EZ-C Series Electrosurgical Generator does not use a fan to cool the internal components, monitoring the internal air temperature is important. Under worst case conditions, it may be necessary to dissipate as much as 180 watts of heat via the convection cooling slots and surface areas.

A thermistor device (R13) in the temperature sense circuit measures the internal air temperature at the left rear corner of the Power Supply/RF board. If the temperature exceeds 65° C, the main microcontroller receives a signal to indicate an over-temperature condition.

An error code displays in the Cut display. When the air temperature decreases to 60° C, operation returns to normal.

R5, R6, R15, and R16 determine a reference voltage, which is then applied to the noninverting input of U2B (LM 393). It is designed to be equal to the voltage at the inverting input of U2B when the thermistor is at 65° C.

At temperatures below 65° C, the output of U2B pin 7 is LOW. When the thermistor temperature exceeds the threshold, the voltage comparator changes state causing the output at U2B pin 7 to go HIGH (+5 Vdc). The HIGH goes to the main microcontroller.

Setup, Tests, and Adjustments

After unpacking or after servicing the Valleylab Force EZ-C Series Electrosurgical Generator, set it up and verify that it functions correctly.

If the generator does not satisfactorily complete the self-test, calibrate the generator to ensure its accuracy.

Setting Up the Generator

Warning

Electric Shock Hazard –pConnect the generator power cord to a properly grounded receptacle. Do not use power plug adapters.

Fire Hazard –pDo not use extension cords.

Caution

Do not stack equipment on top of the generator or place the generator on top of electrical equipment (except a Force Argon Unit). These configurations are unstable and/or do not allow for adequate cooling.

Provide as much distance as possible between the electrosurgical generator and other electronic equipment (such as monitors). An activated electrosurgical generator may cause interference with them.

Notice

If required by local codes, connect the generator to the hospital equalization connector with an equipotential cable.

Connect the power cord to a wall receptacle having the correct voltage. Otherwise, product damage may result.

1. Verify the generator is off by pressing the power switch off (O).
2. Place the generator on any stable flat surface, such as a table, platform, or Valleylab cart. Valleylab recommends carts with conductive wheels. For details, refer to the procedures for your institution or to local codes.

Ensure that the generator rests securely on the cart or platform. The underside of the generator contains four rubber feet and additional holes that allow you to reposition the feet to ensure stability. Use a Phillips screwdriver to remove the rubber feet from the generator. Then, reinstall the feet in the preferred locations.

Provide at least four to six inches of space from the sides and top of the generator for convection cooling. Normally, the top, sides, and rear panel are warm when the generator is in use continuously for extended periods of time.

3. According to the procedures used by your institution, connect an equipotential grounding cable to the grounding lug on the rear panel of the generator. Then, connect the cable to earth ground.
4. Plug the generator power cord into the rear panel receptacle. Secure the cord to the rear panel using the screw and C clamp provided.
5. Plug the generator power cord into a grounded receptacle.

6. Turn on the generator by pressing the power switch on (|). Verify the following:
 - All visual indicators and displays on the front panel illuminate.
 - Activation tones sound to verify that the speaker is working properly.

► **Important**

Status for the last used mode and power settings feature momentarily appears in the Cut display. The selected low (desiccate) setting and high (fulgurate) setting momentarily appear in the Coag display.

7. If the self-test is successful, a tone sounds. Verify the following:
 - Either the Pure button indicator or the Blend button indicator illuminates green, and either the Low button indicator or the High button indicator illuminates green.
 - The right arrow indicator at the Footswitch Selector button illuminates green.
 - Each display shows a power setting.
 - The REM Alarm indicator illuminates red.

If the self-test is not successful, an alarm tone sounds. A number may momentarily appear in the Cut display and, in most cases, the generator is disabled. Note the number and refer to Section 7, *Responding to System Alarms*.

Connections for Bipolar Surgery

If you plan to use a footswitching bipolar instrument, you must connect a footswitch. You may also use a footswitch to activate a handswitching instrument.

Warning

Electric Shock Hazard –

- Do not connect wet accessories to the generator.
- Ensure that all accessories and adapters are correctly connected and that no metal is exposed.

Caution

Accessories must be connected to the proper receptacle type. In particular, bipolar accessories must be connected to the Bipolar Instrument receptacle only. Improper connection of accessories may result in inadvertent generator activation or a REM Contact Quality Monitor alarm.

Figure 6-1.
Bipolar connections (footswitch activation from the Bipolar Footswitch receptacle on the rear panel)

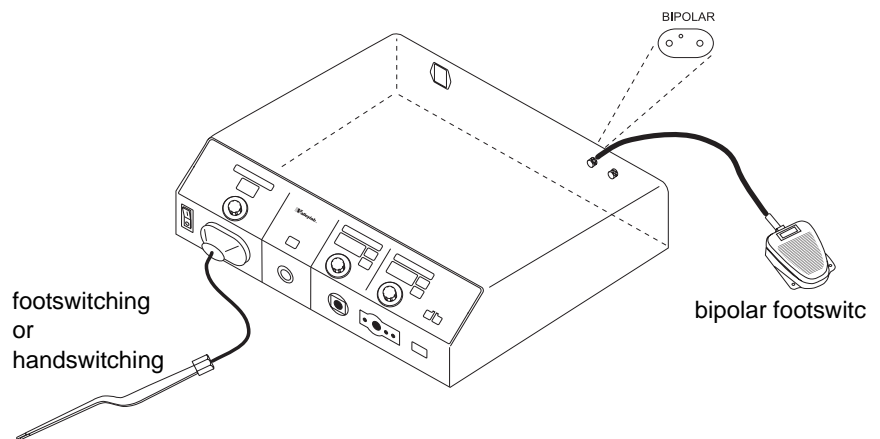

Figure 6-2.
Bipolar connections (footswitch activation from the Footswitch receptacle on the front panel)

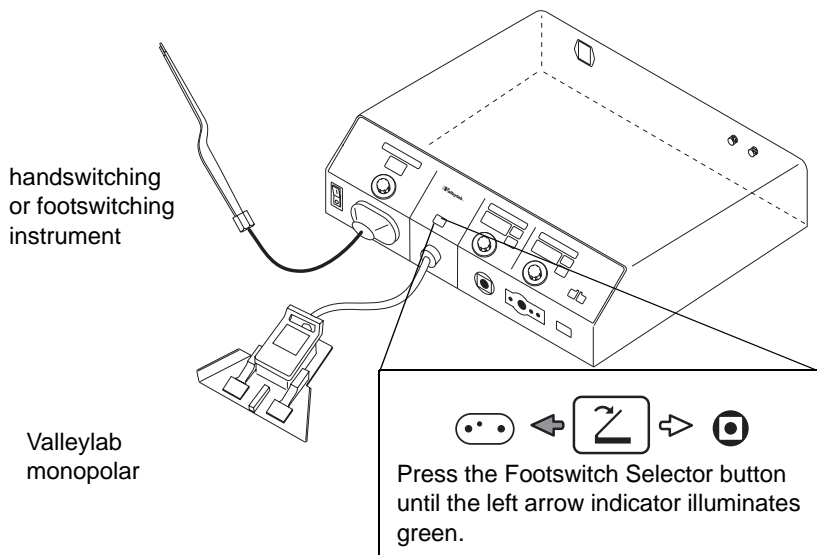
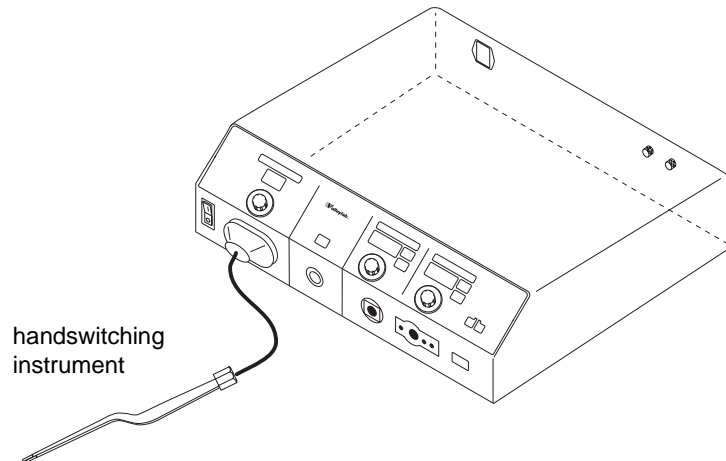

Figure 6-3.
Bipolar connection
(handswitching instrument)



Setting the Bipolar Output

Caution

Set power levels to the lowest setting before testing an accessory.

1. To increase (+) the power, turn the Bipolar Power Control knob clockwise. To decrease (-) the power, turn the knob counterclockwise. The maximum power setting for bipolar output is 70 watts.
2. To display and use the previous power setting, press the Pure and Blend buttons simultaneously.

Connections for Monopolar Surgery

If you plan to use a footswitching monopolar instrument, you must connect a Valleylab monopolar footswitch. You may also use a footswitch to activate a handswitching instrument.

For most procedures, you will connect only one monopolar instrument (handswitching or footswitching).

Warning

Electric Shock Hazard —

- Do not connect wet accessories to the generator.
- Ensure that all accessories and adapters are correctly connected and that no metal is exposed.

Use only a Valleylab monopolar footswitch with the Force EZ-C Series Electrosurgical Generator. Use of an incompatible footswitch may cause unexpected output.

The instrument receptacles on this generator accept only one instrument at a time. Do not attempt to connect more than one instrument at a time into a given receptacle. Doing so will cause simultaneous activation of the instruments.

Figure 6-4.
Monopolar connections
(handswitching instrument)

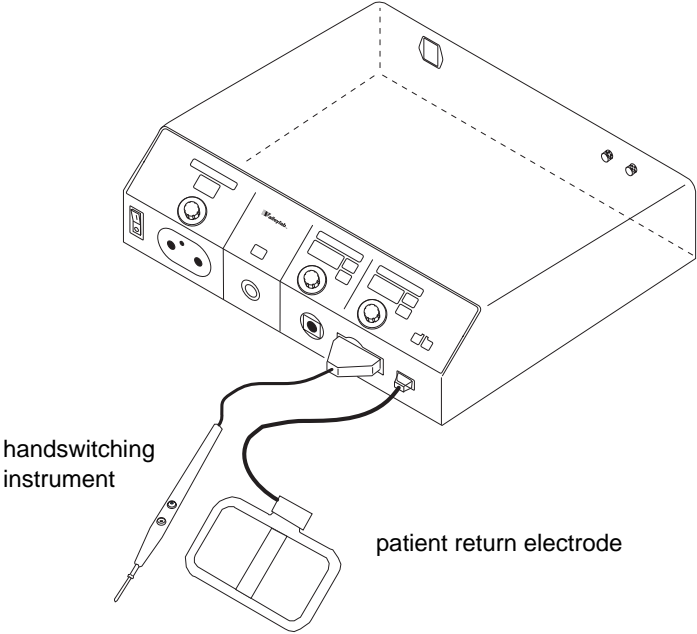

Figure 6-5.
Monopolar connections
(footswitch activation from the
Monopolar Footswitch receptacle
on the rear panel)

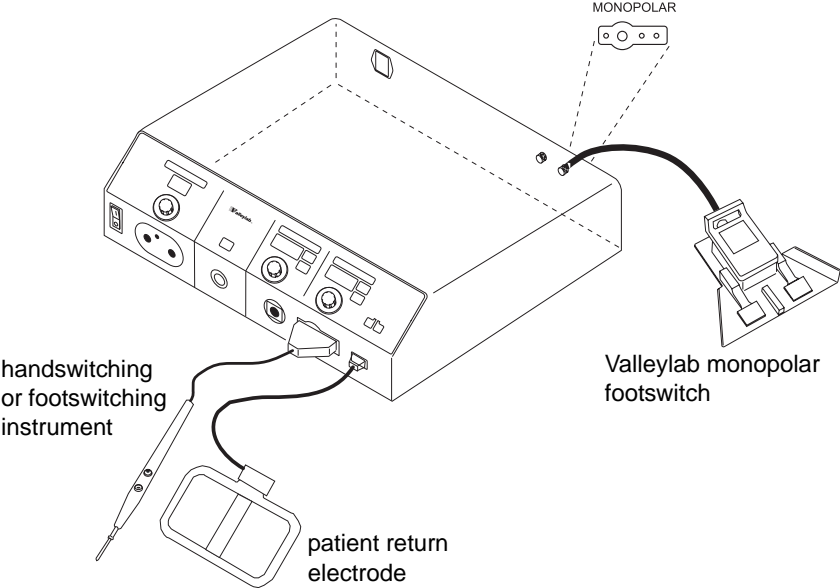
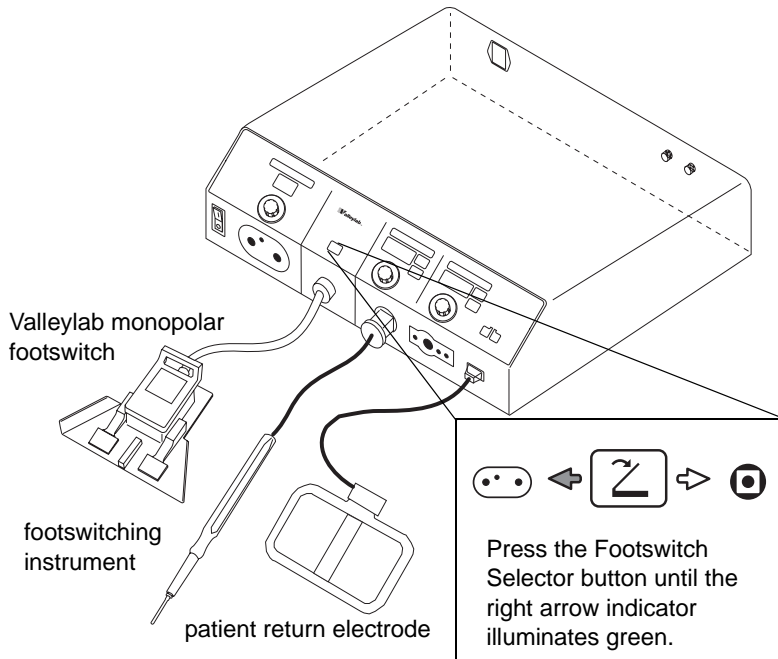

Figure 6-6.
Monopolar connections
(footswitch activation from the
Footswitch receptacle on the
front panel)



Set the Cut and Coag Output

Caution

Set power levels to the lowest setting before testing an accessory.

To display and use the previous power settings, press the Pure and Blend buttons simultaneously.

1. To select a cut mode, press the Pure or Blend button. The indicator in the button of the selected mode illuminates green.
2. To select a coag mode, press the Low or High button. The indicator in the button of the selected mode illuminates green.

To verify the selected low (desiccate) or high (fulgurate) coag setting, press and hold the Low or High button. While you press the Low button, a 1 (low 1), 2 (low 2), or 3 (low 3) appears in the Coag display. While you press the High button, a 1 (high 1) or 2 (high 2) appears in the Coag display. To change these settings, refer to *Setting Up the Special Features* in this section.

3. To increase (+) the power, turn the Cut or Coag Power Control knob clockwise. To decrease (–) the power, turn the knob counterclockwise.
 - The maximum power setting for the pure cut mode is 300 watts.
 - The maximum power setting for the blend cut mode is 200 watts.
 - The maximum power setting for the low (desiccate) coag mode and the high (fulgurate) coag mode is 120 watts.

Using Two Generators Simultaneously

Caution

Do not stack equipment on top of the generator or place the generator on top of electric equipment (except a Force Argon Unit). These configurations are unstable and/or do not allow adequate cooling.

You can use two generators (and two patient return electrodes) simultaneously on the same patient, provided the generators are the same type (both are isolated or both are ground referenced). However, the two generators are not synchronized. One return electrode frequently acquires a high positive voltage while the other acquires an opposite negative voltage. When this occurs, the potential voltage difference between them may cause the current to flow from one patient return electrode to the other. The current causes no harm if it produces no sparks or high current densities on the patient.

Place each patient return electrode as close as possible to the site of the surgery to be performed by the generator to which it is connected. Ensure that the two patient return electrodes do not touch.

Setting Up the Special Features

Five special features are available to customize the Force EZ-C Series Electrosurgical Generator. Refer to the following table for setup information. You must enter the setup mode to modify the special features.

Entering the Setup Mode

Important
 During the setup mode, dashes (--) appear in the Bipolar display and the Bipolar Power Control knob has no function.

Press the Footswitch Selector button, the Low button, and the High button simultaneously.

A number (1, 2, or 3) appears in the Coag display, and the indicator in the Low or High button flashes.

Special Feature	Action	Cut Display	Cut Button Indicator	Coag Display	Coag Button Indicator
Low (desiccate) coag settings	<ol style="list-style-type: none"> 1. Press the Low button. 2. Turn the Coag Power Control knob to select the desired setting: <ul style="list-style-type: none"> 1 = low 1 2 = low 2 3 = low 3 	---	blank	1, 2, or 3	Low flashes

Special Feature	Action	Cut Display	Cut Button Indicator	Coag Display	Coag Button Indicator
High (fulgurate) coag settings	<ol style="list-style-type: none"> 1. Press the High button. 2. Turn the Coag Power Control knob to select the desired setting: 1 = high 1 2 = high 2 	---	blank	1 or 2	High flashes
Recall of most recently used modes and power settings	<ol style="list-style-type: none"> 1. Press the Pure button. 2. Turn the Cut Power Control knob to turn on or turn off this feature: 0 = off 1 = on 	0 or 1	Pure flashes	---	blank
Default coag mode	Press the Low button.	---	blank	1, 2, or 3	Low flashes
	or Press the High button.	---	blank	1 or 2	High flashes
Important					
The default coag mode feature is available only when the most recently used modes and power settings feature is turned off.					
When you exit the setup mode, the generator saves the coag mode selected at that time as the default coag mode.					
Original default settings	Press the Pure and Blend buttons simultaneously. A tone sounds.	The generator resets all modes, power settings, and special features to the original factory defaults.			

Exiting the Setup Mode

To exit and save changes, press the Footswitch Selector button. If you changed the low or high coag settings during the setup mode, these new settings will be in effect. Otherwise, the generator returns to the modes and power settings (bipolar, cut, and coag) selected before entering the setup mode.

To exit and not save changes, press the power switch off (O).

Changing the Mode

You cannot change the mode while the generator is activated. To change the cut or coag mode, press the desired mode button. The indicator in the button of the selected mode illuminates green. You can activate only one mode at a time.

To verify the selected low (desiccate) or high (fulgurate) coag setting, press and hold the Low or High button. While you press the Low button, a 1 (low 1), 2 (low 2), or 3 (low 3) appears in the Coag display. While you press the High button, a 1 (high 1) or 2 (high 2) appears in the Coag display. To change these settings, refer to *Setting Up the Special Features* in this section.

When you change the cut or coag mode, the power setting remains the same unless it exceeds the maximum for the new mode. In that case, it reverts to the maximum for the new mode. For example, if you set the power to 250 for pure cut, when you select the blend mode, the setting changes to 200, the maximum for blend. If, however, you set the power to 65 in the low (desiccate) coag mode, when you select high (fulgurate), the power setting does not change because it falls within that mode's range.

Changing the Power Setting

You can change the power setting when the generator is on, including when it is activated.

To increase (+) the power, turn the Bipolar, Cut, or Coag Power Control knob clockwise.

To decrease (–) the power, turn the appropriate knob counterclockwise.

As you turn the knob, the power changes by one setting (1, 5, or 10 watts) based on the settings available for the selected mode. For available power settings, refer to Section 4, *Output Characteristics*.

When you change the power setting while the generator is activated, the power changes by one setting per second to prevent rapid increases or decreases in power to the surgical site. If you try to set the power above the maximum setting or below the minimum setting, a tone sounds.

Activating the Surgical Instrument

Notice

Do not activate the generator until the forceps have made contact with the patient. Product damage may occur.

► Important

To activate an instrument in the blend mode, press the Cut (yellow) button on the handswitching instrument, or press the Cut pedal on the monopolar footswitch.

To activate a handswitching instrument, use the controls on the instrument or on the appropriate footswitch. To activate a footswitching instrument, you must use a footswitch.

To reduce the possibility of alternate site burns that may be caused by RF leakage currents, avoid unnecessary and prolonged activation of the generator.

If you use bipolar output when a return electrode is applied to the patient, the generator automatically deactivates the return electrode circuit to eliminate the possibility of current dispersal.

Mode	Handswitching	Footswitching	Activation Indicator
Bipolar	Close forceps tines firmly	Bipolar footswitch connected to rear panel – press pedal or Monopolar footswitch connected to front panel – verify that the left arrow at the Footswitch Selector button illuminates and press either pedal	Activation tone sounds – Bipolar indicator illuminates blue
Monopolar	Press Cut or Coag button or Close forceps tines firmly	Monopolar footswitch connected to front panel – verify that the right arrow at the Footswitch Selector button illuminates and press the cut or coag pedal or Monopolar footswitch connected to rear panel – press cut or coag pedal	Activation tone sounds – Cut indicator illuminates yellow or Coag indicator illuminates blue

Periodic Safety Check

Warning

Electric Shock Hazard — When taking measurements or troubleshooting the generator, take appropriate precautions, such as using isolated tools and equipment, using the “one hand rule,” etc.

Electric Shock Hazard — Do not touch any exposed wiring or conductive surfaces while the generator is disassembled and energized. Never wear a grounding strap when working on an energized generator.

► Important

When testing RF equipment, follow these test procedures to duplicate manufacturer test data. Keep test leads to the minimum length usable; lead inductance and stray capacitance can adversely affect readings. Carefully select suitable ground points to avoid ground loop error in measurements.

The accuracy of most RF instruments is approximately 1-5% of full scale. Using uncompensated scope probes causes large errors when measuring high voltage RF waveforms.

Caution

The generator contains electrostatic-sensitive components. When repairing the generator, work at a static-control workstation. Wear a grounding strap when handling electrostatic-sensitive components, except when working on an energized generator. Handle circuit boards by their nonconductive edges. Use an antistatic container for transport of electrostatic-sensitive components and circuit boards.

Perform the following safety check every six months to verify that the Force EZ-C Series Electrosurgical Generator is functioning properly. Record the test results for reference in future tests. If the generator fails to meet any of the checks, refer to Section 7, *Troubleshooting*.

These are the safety checks:

- Inspect the generator and accessories
- Inspect the internal components
- Test the generator
- Verify REM function
- Confirm outputs
- Check leakage current and ground resistance

Recommended Test Equipment

- Digital voltmeter—Fluke 77 or 87, or equivalent
- True RMS voltmeter—Fluke 8920, or equivalent
- Oscilloscope—Tektronix 2445, or equivalent
- Leakage current tester—Use IEC 60601-1 1988, Figure 15 load device or commercially available leakage tester
- Leakage table—per IEC 60601-2-2 1991, Figure 104

Inspecting the Generator and Accessories

Equipment

- Bipolar footswitch or monopolar footswitch
- Bipolar instrument cords (handswitching and footswitching)
- Monopolar instrument cords (handswitching and footswitching)

Before You Start

1. Turn off (O) the generator by pressing the front panel power switch.
2. Disconnect the power cord from the wall receptacle.

Rear Panel

1. Check the rear panel footswitch receptacles for obstructions or damage. Check for a secure fit by inserting the bipolar footswitch or monopolar footswitch connector into the appropriate receptacle.
2. Remove the fuse and verify correct voltage and current rating. Refer to Section 4, *Performance Characteristics*.

If either connection is loose, replace the Footswitch board assembly. Refer to Section 8, *Footswitch Board Assembly*.

Front Panel

1. Check the Footswitch receptacle for obstructions or damage. Check for a secure fit by inserting the monopolar footswitch connector into the receptacle.

If the connection is loose, replace the receptacle. Refer to Section 8, *Front Panel Footswitch Receptacle*.

2. Check the Bipolar Instrument receptacle for obstructions or damage. Insert the bipolar instrument connectors (footswitching and handswitching) into the receptacle to verify a secure fit.

If the connection is loose, replace the front panel assembly. Refer to Section 8, *Front Panel*.

3. Check the Monopolar Instrument receptacle and the Accessory Instrument receptacle for obstructions or damage. Insert the monopolar instrument connectors (footswitching and handswitching) into the appropriate receptacles to verify a secure fit.

If any of the connections are loose, replace the front panel assembly. Refer to Section 8, *Front Panel*.

4. Check the Patient Return Electrode receptacle for a broken pin or an obstruction. If the receptacle is damaged or obstructed, replace the front panel assembly. Refer to Section 8, *Front Panel*.

Footswitch

1. Remove the footswitch from the generator.
2. Disassemble the footswitch connector. Inspect the connector for damage or corrosion.
3. Reassemble the footswitch connector.
4. Inspect the footswitch for damage.
5. Reconnect the footswitch to the generator.

Power Cord

1. Remove the power cord from the unit and ensure that it is unplugged from the wall receptacle.
2. Inspect the power cord for damage.
3. Reconnect the power cord to the generator and wall receptacle.

Inspecting the Internal Components

Equipment

- Phillips screwdriver

Caution

The generator contains electrostatic-sensitive components. When repairing the generator, work at a static-control workstation. Wear a grounding strap when handling electrostatic-sensitive components, except when working on an energized generator. Handle circuit boards by their nonconductive edges. Use an antistatic container for transport of electrostatic-sensitive components and circuit boards.

Procedure

1. Verify that the generator is off by pressing the power switch off (O).
2. Loosen the four screws that secure the cover to the chassis. Lift the cover off the chassis. Set the cover aside for reinstallation.
3. Verify that all connectors are firmly seated.
4. Inspect each board for damaged components, wires, cracks, and corrosion.
 - If you find evidence of damage on the Control board, Display board, or Footswitch board, replace the board. Refer to *Section 8, Control Board*, or *Section 8, Display Board*.
 - If you find evidence of damage on the Power Supply/RF board, replace the board only if the damage is severe. Refer to *Section 8, Power Supply/RF Board*.
5. Reinstall the cover on the generator. Position the cover above the chassis and slide it down. Tighten the four screws that secure the cover to the chassis.

Testing the Generator

Warning

Use the generator only if it has completed the self-test as described. Otherwise, inaccurate power outputs may result.

Important

When testing RF equipment, follow these test procedures to duplicate manufacturer test data. Keep test leads to the minimum length usable; lead inductance and stray capacitance can adversely affect readings. Carefully select suitable ground points to avoid ground loop error in measurements.

The accuracy of most RF instruments is approximately 1-5% of full scale. Using uncompensated scope probes causes large errors when measuring high voltage RF waveforms.

Caution

Do not turn the activation tone down to an inaudible level. The activation tone alerts personnel when an accessory is active.

Turning on the generator initiates an internal self-test to verify the calibration. The self-test also checks the operation of the speaker, all indicators, and the displays.

1. Turn on the generator by pressing the power switch on (|). Verify the following:
 - All visual indicators and displays on the front panel illuminate.
 - Status for the last used modes and power settings feature momentarily appears in the Cut display. The selected low and high settings momentarily appear in the Coag display.
 - Tones sound to verify that the speaker is working properly.
2. If the self-test is successful, a tone sounds. Verify the following:
 - Either the Pure button indicator or the Blend button indicator illuminates green, and either the Low button indicator or the High button indicator illuminates green.
 - The right arrow indicator at the Footswitch Selector button illuminates green.
 - Each display shows a power setting.
 - The REM Alarm indicator illuminates red.
3. If the self-test is not successful, an alarm tone sounds. A number appears in the Cut display and the generator disables RF output.

If the generator is not calibrated, calibrate it and retest the generator.

If the generator is calibrated, note the number and refer to Section 7, *Responding to System Alarms*.

Verifying REM Function

Equipment

- REM plug and resistance substitution box

Procedure

1. Set the resistance substitution box to 120 ohms. Connect the resistance box to the generator and confirm that the REM Alarm indicator illuminates green.
2. Slowly increase the resistance and verify that the REM alarm sounds at 135 ± 5 ohms.
3. Decrease the resistance to 60 ohms and verify that the REM Alarm indicator illuminates green.
4. Increase the resistance to 100 ohms and verify that the REM alarm sounds.
5. Decrease the resistance to 30 ohms and verify that the REM Alarm indicator illuminates green.
6. Decrease the resistance to 10 ohms and verify that the REM Alarm indicator illuminates green.
7. Decrease the resistance to 3 ohms and verify that the REM alarm sounds.
8. Switch to a connector without the pin, and increase the resistance from 3 ohms to 24 ohms. Verify that the REM alarm sounds.

Confirming Outputs

Use this procedure to ensure the accuracy of the generator. Always confirm the output at these times:

- after calibrating the generator
- every six months

Equipment

- Two small test cables (less than 24 inches long) with banana plugs
- Current transformer
- True RMS voltmeter (such as the Fluke 8920 or equivalent)
- 10, 100, 200, 300, 500, 750, 2000, 3000 ohm 1% noninductive power resistors. (Series or parallel combinations of other values may be substituted if these exact values are not available.)
- Bipolar footswitch and monopolar footswitch

Checking the Bipolar Output

1. Verify that the generator successfully completes the self-test as described in *Testing the Generator* in this section.
2. Connect the test equipment for bipolar output.
 - a. Connect the two test cables to the Bipolar Instrument receptacle.
 - b. Pass one test cable through the current transformer and connect the current transformer to the voltmeter.
 - c. Connect the appropriate power resistor (refer to the table below) across the output receptacle at the end of the test cables.
 - d. Connect the bipolar footswitch to the Bipolar Footswitch receptacle on the rear panel.
3. Set the bipolar power to 70.
4. Test the output current for the bipolar mode.
 - a. Press the footswitch pedal and, while activating the generator, note the output on the voltmeter.
 - b. Release the footswitch pedal.
 - c. Based on the voltmeter setting and the current transformer you are using, calculate and record the output current.
 - d. Verify that the generator output is within the range specified in the table below.
5. Repeat steps 2 through 4 for each resistor.

If the output is outside the specified range, calibrate the generator as described in *Calibrating the Force EZ-C Series Electrosurgical Generator* in this section. Then repeat this procedure. If the output remains outside the specified range, call the Valleylab Service Center.

Generator Output (A_{rms})	
Resistor	Bipolar Mode (bipolar power @ 70 watts)
10 ohm	1.300-1.558
100 ohm	0.771-0.897
750 ohm	0.233-0.271

Checking the Monopolar Output

Step 1 – Check the output for the cut modes

1. Verify that the generator successfully completes the self-test as described in *Testing the Generator* in this section.
2. Connect the test equipment for monopolar output.
 - a. Connect one test cable to the left contact in the Monopolar Instrument receptacle. Pass the test cable through the current transformer and connect the current transformer to the voltmeter.
 - b. Connect the second test cable to both pins of the Patient Return Electrode receptacle.
 - c. Connect the appropriate power resistor (refer to the table below) across the output receptacles at the end of the test cables.
 - d. Connect the monopolar footswitch to the Monopolar Footswitch receptacle on the rear panel of the generator.
3. Press the appropriate mode button (refer to the table below).
4. Set the cut power (refer to the table below).
5. Test the monopolar cut output.
 - a. Press the footswitch cut pedal and, while activating the generator, note the output on the voltmeter.
 - b. Release the footswitch pedal.
 - c. Based on the voltmeter setting and the current transformer you are using, calculate and record the output current.
 - d. Verify that the generator output is within the range specified in the table below.
6. Repeat steps 2 through 5 for each cut mode and resistor combination.

If the output is outside the specified range, calibrate the generator as described in *Calibrating the Force EZ-C Series Electrosurgical Generator* in this section. Then repeat this procedure. If the output for one or more cut modes remains outside the specified range, call the Valleylab Service Center.

Generator Output (A_{rms})		
Resistor	Pure Mode (cut power @ 300 watts)	Blend Mode (cut power @ 200 watts)
10 ohm	1.202-1.296	0.980-1.020
300 ohm	0.922-1.072	0.753-0.876
2000 ohm	N/A	0.277-0.322
3000 ohm	0.200-0.234	N/A

Step 2 – Check the output for the coag modes

1. Connect the appropriate power resistor (refer to the table below) across the output receptacles at the end of the test cables.
2. Press the appropriate mode button (refer to the table below).
3. Set the coag power to 120 watts.
4. Test the monopolar coag output.
 - a. Press the footswitch coag pedal and, while activating the generator, note the output on the voltmeter.
 - b. Release the footswitch pedal.
 - c. Based on the voltmeter setting and the current transformer you are using, calculate and record the output current.
 - d. Verify that the generator output is within the range specified in the table below.
5. Repeat steps 1 through 4 for each coag mode setting and resistor combination. For information on changing the low and high settings, refer to *Setting Up the Special Features* in this section.

If the output is outside the specified range, calibrate the generator as described in *Calibrating the Force EZ-C Series Electrosurgical Generator* in this section. Then repeat this procedure. If the output for one or more coag modes remains outside the specified range, call the Valleylab Service Center.

Generator Output (A_{rms})

Resistor	Low 1 Setting (coag power @ 120 watts)	Low 2 Setting (coag power @ 120 watts)	Low 3 Setting (coag power @ 120 watts)	High 1 Setting (coag power @ 120 watts)	High 2 Setting (coag power @ 120 watts)
200 ohm	N/A	0.714-0.831	0.714-0.831	N/A	N/A
500 ohm	0.452-0.525	N/A	N/A	0.452-0.525	0.452-0.525
2000 ohm	N/A	0.093-0.125	0.127-0.173	N/A	N/A

Checking Low Frequency Leakage Current and Ground Resistance

Check the leakage current and ground resistance before returning the Force EZ-C Series Electrosurgical Generator to clinical use.

Equipment

- DVM
- Leakage current test load per IEC 60601-1 1988, Figure 15

Figure 6-7.
The leakage current test circuit

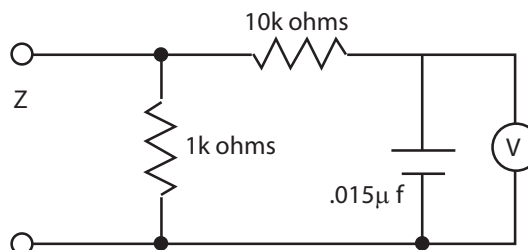

Output Receptacles and REM Source Current

1. Set the DVM to AC volts (200 mV) and connect the leakage current test circuit.
2. Turn on the generator.
3. Measure between all the output receptacles (including the Patient Return Electrode receptacle) and earth ground. Record the largest reading.
4. Determine the leakage current using the conventional 1 microamp per 1 millivolt.
5. Verify under normal conditions (ground closed, normal polarity) the leakage current is less than 10 microamps. If the leakage current is greater than 10 microamps, call the Valleylab Service Center.
6. Verify under single fault conditions (ground open) the leakage current is less than or equal to 50 microamps. If the leakage current is greater than 50 microamps, call the Valleylab Service Center.

Chassis or Earth Leakage

1. Set the DVM to AC volts (200 mV) and connect the leakage current test circuit.
2. Turn on the generator.
3. Measure between the chassis and earth ground.
4. Determine the leakage current using the conventional 1 microamp per 1 millivolt.

5. Verify under normal conditions (ground closed, normal polarity) the leakage current is less than 20 microamps. If the leakage current is greater than 20 microamps, call the Valleylab Service Center.
6. Verify under single fault conditions (ground open) the leakage current is less than or equal to 100 microamps. If the leakage current is greater than 100 microamps, call the Valleylab Service Center.

Output Receptacles and REM Sink Current

1. Set the DVM to AC volts (200 mV) and connect the leakage current test circuit.
2. Turn on the generator at 140 Vac and connect the end of the leakage current test circuit to 140 volts through a 120 k Ω resistor.
3. Connect the other side of the IEC leakage load to each of the output receptacles (including the Patient Return Electrode receptacle)
4. Determine the leakage current using the conventional 1 microamp per 1 millivolt.
5. Verify the leakage current is less than or equal to 20 microamps. If the leakage current is greater than 20 microamps, call the Valleylab Service Center.

Checking High Frequency Leakage Current and Ground Resistance

Check the high frequency leakage current and ground resistance before returning the Force EZ-C Series Electrosurgical Generator to clinical use. Check the leakage current at these times:

- after calibrating the generator
- every six months

Equipment

- 200 ohm, 250 watt, noninductive resistor
- Current transformer
- True RMS voltmeter (Fluke 8920 or equivalent)
- Bipolar and monopolar footswitches and handswitching accessories
- Leakage table—per IEC 60601-2-2 1991, Figure 104

Checking Monopolar High Frequency Leakage Current

1. Connect the 200 ohm load from the active accessory through the current transformer to the equipotential ground lug on the rear of the generator.
2. Connect the current transformer to a true RMS voltmeter.
3. Connect a monopolar footswitch to the Monopolar Footswitch receptacle at the rear of the generator.

4. Activate the footswitch in each monopolar mode at the maximum control setting. Record the leakage current. It should not exceed 150 mA for any mode.
5. If the high frequency leakage exceeds 150 mA, call the Valleylab Service Center for further instructions.

Checking Bipolar High Frequency Leakage Current

1. Remove the monopolar accessories, and connect the 200 ohm load from one side of the bipolar output through the current transformer to the equipotential ground lug on the rear of the generator.
2. Connect the current transformer to the true RMS voltmeter.
3. Connect a bipolar footswitch to the Bipolar Footswitch receptacle at the rear of the generator.
4. Activate the footswitch in each mode at maximum control setting. Record the leakage current. It should not exceed 60 mA for any mode.
5. If the high frequency leakage exceeds 60 mA, call the Valleylab Service Center for further instructions.

Calibrating the Force EZ-C Series Electrosurgical Generator

Notice

After completing any calibration step, proceed to the next step to save the values from the completed calibration step.

The calibration procedure consists of eight steps. During calibration you verify information specific to the Force EZ-C Series Electrosurgical Generator, adjust the calendar, and adjust the clock. You also adjust the REM circuit and several values, or factors, that ensure the proper operation of the generator.

The following table summarizes the calibration steps and the values you can adjust. Certain values are not adjustable, but require verification.

Calibration Step	Description	Adjustable?
1	Force EZ-C Series Electrosurgical Generator data	No (verify value)
	Generator model number	No (verify value)
	Master microcontroller software version	No (verify value)
	Feedback microcontroller software version	No (verify value)
2	Calendar	
	Day	Yes
	Month	Yes
	Year	Yes
3	Clock	
	Hour	Yes
	Minute	Yes
4	REM impedance	No (verify values)
5	Current sense gain factor	Yes
6	Voltage sense gain factor	Yes
7	Reactance gain factor	Yes
8	ECON factor	No

Preparing for Calibration

You will need the following equipment to calibrate the Force EZ-C Series Electrosurgical Generator:

- Bipolar footswitch and monopolar footswitch
- REM plug and resistor substitution box
- Two small test cables (less than 24 inches long) with banana plugs
- Current transformer (such as the Pearson Model 411 or equivalent)
- True RMS voltmeter (such as the Fluke 8920A or equivalent)
- Noninductive power resistors (such as a Dale NH-250) with these values (in ohms): 10, 30, 50, 100, 200, 500, 750, 2000, and 3000.

If these exact values are not available, you may substitute series or parallel combinations of other values.

- X1000 high voltage scope probe (TEK P6015A or equivalent)
- Oscilloscope (Tek 2445B or equivalent)

Entering Calibration Mode

Notice

After completing any calibration step, proceed to the next step to save the values from the completed calibration step.

When you are in calibration mode, the calibration step number appears in the Bipolar display. The value(s) associated with each calibration step appear in the Cut and Coag displays. Use the Cut and Coag Power Control knobs to adjust the displayed values.

1. If the generator is off, turn it on.

If you removed and/or replaced the battery, alarm number 212 may appear in the Cut display the first time you turn on the generator.

2. To enter calibration mode, simultaneously press the Footswitch Selector, Pure, and Desiccate buttons.

The first calibration step number (1) appears in the Bipolar display. For instructions on completing this step, refer to *Calibration Step 1 – Verify the Force EZ-C Series Electrosurgical Generator data*.

If an error occurs during calibration, an alarm number will appear in the Cut display. Note the number and refer to Section 7, *Responding to System Alarms* for the appropriate action to take.

Exiting Calibration Mode

Notice

After calibration, the generator will be ready to use only after you initiate the internal self-test by turning the generator off, then on.

To exit calibration mode, turn off the generator. You can exit calibration mode at any time.

- To save the changes for the present calibration step, turn the Bipolar Power Control knob clockwise until the next calibration step number appears in the Bipolar display. Then, turn off the generator to exit calibration mode. Calibration values are saved one step at a time.

For example, if you only want to adjust the clock, first enter calibration mode and turn the Bipolar Power Control knob until the system displays calibration step number 3. Next, change the hour and minute values. Then, turn the Bipolar Power Control knob clockwise once (to the next step). This saves the changes for step 3 and displays the next calibration step number (4). After saving the changes, turn off the generator to exit calibration mode.

or

- To exit calibration mode without saving the changes for the present calibration step, turn off the generator. Do not turn the Bipolar Power Control knob at the end of the step. The values that were in effect before you started that step remain in effect.

Calibration Step 1 – Verify the Force EZ-C Series Electrosurgical Generator Data

In calibration step 1, you verify the Force EZ-C Series Electrosurgical Generator model number and the software version numbers for the main and feedback microcontrollers. You cannot adjust these values.

- The generator code (model number) for the Force EZ-C Series Electrosurgical Generator is 32.
- The software version number for the main microcontroller may vary among manufacturing lots, but should never be zero (0).
- The software version number for the feedback microcontroller may vary among manufacturing lots, but should never be zero (0).

If one or more of the values that appear as you proceed through this calibration step are not correct, call the Valleylab Service Center.

1. In the Bipolar display, verify that the calibration step number is 1.
2. In the Cut display, verify the Force EZ-C Series Electrosurgical Generator model number (32).
3. In the Coag display, verify that the main microcontroller version number is a value other than zero (0).

4. To display the feedback microcontroller version number, press the High button. Verify that the version number in the Coag display is a value other than zero (0).
5. To proceed to the next calibration step, turn the Bipolar Power Control knob clockwise until 2 appears in the Bipolar display.

At the end of each calibration step, turn the Bipolar Power Control knob clockwise to advance to the next step. If you need to return to a previous calibration step, turn the knob counterclockwise.

Next, check the month, day, and year values as described in *Calibration Step 2 – Adjust the calendar*.

Calibration Step 2 – Adjust the Calendar

The generator stores the month, date (day of the month), and year values in the real-time clock on the Control board. Use the Coag Power Control knob on the front panel to adjust these values.

- To increase the displayed value, turn the Coag Power Control knob clockwise.
- To decrease the value, turn the Coag Power Control knob counterclockwise.

1. Verify that the Bipolar display shows calibration step number 2.
2. To select the day, turn the Coag Power Control knob until the correct value (1–31) appears in the Coag display.
3. To display the month value, press the Low button once. (The Low button cycles through the day, month, and year values.)

To select the month, turn the Coag Power Control knob until the correct value (1–12) appears in the Coag display.

4. To display the year value, press the Low button once.

To select the year, turn the Coag Power Control knob until the correct value (0–99) appears in the Coag display.

Examples:

- For 1997, set the year value to 97.
 - For 2001, set the value to 1.
5. To save the day, month, and year values and go to calibration step 3, turn the Bipolar Power Control knob clockwise.

Next, check the hour and minute values as described in *Calibration Step 3–Adjust the clock*.

Calibration Step 3 – Adjust the Clock

The generator stores the hour and minute values in the real-time clock on the Control board. Valleylab originally set the clock for Mountain Standard Time at Boulder, Colorado, USA. The clock runs in the 24-hour (that is, military time) format.

1. Verify that the Bipolar display shows calibration step number 3.
2. To select the hour, turn the Coag Power Control knob until the correct value (0–23) appears in the Coag display.

Examples:

- For 2 AM, set the hour value to 2.
 - For 2 PM, set the value to 14.
3. To display the minute value, press the Low button once. (The Low button cycles through the hour and minute values.)

To select the minute value, turn the Coag Power Control knob until the correct value (0–59) appears in the Coag display.

4. To save the hour and minute values and go to calibration step 4, turn the Bipolar Power Control knob clockwise.

Next, check the REM impedance as described in *Calibration Step 4 – Check the REM impedance*.

Calibration Step 4 – Check the REM Impedance

Equipment

- Two short test cables (less than 24 inches long) with banana plugs
- REM plug
- Resistor substitution box

Procedure

► **Important**

When testing RF equipment, follow these test procedures to duplicate manufacturer test data. Keep test leads to the minimum length usable; lead inductance and stray capacitance can adversely affect readings. Carefully select suitable ground points to avoid ground loop error in measurements.

The accuracy of most RF instruments is approximately 1-5% of full scale. Using uncompensated scope probes causes large errors when measuring high voltage RF waveforms.

1. Verify that the Bipolar display shows calibration step number 4.
2. Connect the REM plug and the resistor substitution box to the Patient Return Electrode receptacle on the front panel.
3. Verify that the Coag display shows 135.
4. Set the resistor substitution box to 135 ohms.
 - a. Turn the Coag Power Control knob clockwise once. The Coag display will flash 135 for a few seconds while the REM frequency is adjusted.
 - b. After the flashing stops, verify that 70 appears in the Coag display.
5. Set the resistor substitution box to 70 ohms.
 - a. Turn the Coag Power Control knob clockwise once.
 - b. Verify that 10 appears in the Coag display.
6. Set the resistor substitution box to 10 ohms.
 - a. Turn the Coag Power Control knob clockwise once.
 - b. Verify that the letters OP appear in the Coag display.
7. Set the resistor substitution box to the open position.
8. To save the REM calibration values and go to calibration step 5, turn the Bipolar Power Control knob clockwise.
9. Remove the REM plug and resistor substitution box.

Next, check the current sense gain factor as described in *Calibration Step 5 – Check and adjust the current sense gain.*

Calibration Step 5 – Check and Adjust the Current Sense Gain

Equipment

- Two short test cables (less than 24 inches long) with banana plugs
- Current transformer (such as the Pearson Model 411 or equivalent)
- True RMS voltmeter (such as the Fluke 8920 or equivalent)
- 10 ohm noninductive power resistor (such as the Dale NH-250)
- Bipolar footswitch and monopolar footswitch

Checking the Current Sense Gain for Bipolar Output

Caution

To avoid inadvertent coupling and/or shunting of RF currents around the resistor elements, keep the resistors at least 10.2 cm (4 in.) away from any metal surface including tabletops and other resistors. This is especially true if several resistors are connected in series or parallel to obtain a specified value. Do not allow the resistor bodies to touch each other.

Notice

Do not activate the generator with any load resistor higher than 10 ohms while calibrating the current sense gain. Otherwise, product damage will result.

1. Verify that the Bipolar display shows calibration step number 5.
The Cut and Coag displays show the I (current) factor. If it is four or more digits, the most significant digits appear in the Cut display.
2. Connect the test equipment for bipolar output.
 - a. Connect the two test cables to the Bipolar Instrument receptacle.
 - b. Pass one test cable through the current transformer and connect the current transformer to the voltmeter.
 - c. Connect the 10 ohm resistor across the output jacks at the end of the test cables.
 - d. Connect the bipolar footswitch to the Bipolar Footswitch receptacle on the rear panel.

or

Connect the monopolar footswitch to the Footswitch receptacle on the front panel and press the Footswitch Selector button until the left arrow indicator illuminates green.

3. Check and adjust the I factor for bipolar output.
 - a. Press the footswitch pedal and check the voltmeter for a reading equivalent to $1.50 +0/-0.03 A_{rms}$ (1.47 to $1.50 A_{rms}$).
 - b. Stop activation. If the output current was not within the stated range, adjust the I factor. Use the Coag Power Control knob for small adjustments and the Cut Power Control knob for larger adjustments.

Approach the value from the low side to give consistent calibration results. Adjust the I factor until the current is as close as possible to $1.50 A_{rms}$, but not over $1.50 A_{rms}$.

Repeat 3a and 3b until the output current is within the stated range.

4. Disconnect the test cables from bipolar output.

Checking the Current Sense Gain for Monopolar Output

Caution

To avoid inadvertent coupling and/or shunting of RF currents around the resistor elements, keep the resistors at least 10.2 cm (4 in.) away from any metal surface including tabletops and other resistors. This is especially true if several resistors are connected in series or parallel to obtain a specified value. Do not allow the resistor bodies to touch each other.

Notice

Do not activate the generator with any load resistor higher than 10 ohms while calibrating the current sense gain. Otherwise, product damage will result.

1. Connect the test equipment for monopolar output.
 - a. Connect the test cables to the Monopolar Instrument receptacle.
 - b. Verify that the 10 ohm resistor is connected to the test cables through the current transformer.
 - c. Connect a monopolar footswitch to the Monopolar Footswitch receptacle on the rear panel.
2. Check and adjust the I factor for the pure mode.
 - a. Press the Pure button.
 - b. Press the footswitch cut pedal and check the voltmeter for a reading equivalent to $1.25 +0/-0.025 A_{rms}$ (1.225 to $1.25 A_{rms}$).
 - c. Stop activation. If the output current was not within the stated range, use the Cut and Coag Power Control knobs to adjust the I factor.

Approach the value from the low side. Adjust until the current is as close as possible to $1.25 A_{rms}$, but not over $1.25 A_{rms}$.

Repeat 2b and 2c until the output current is within the stated range.

3. Check and adjust the I factor for the blend mode.
 - a. Press the Blend button.
 - b. Press the footswitch cut pedal and check the voltmeter for a reading equivalent to $1.0 \pm 0.02 A_{\text{rms}}$ (0.98 to $1.0 A_{\text{rms}}$).
 - c. Stop activation. If the output current was not within the stated range, use the Cut and Coag Power Control knobs to adjust the I factor.

Approach the value from the low side. Adjust until the current is as close as possible to $1.0 A_{\text{rms}}$, but not over $1.0 A_{\text{rms}}$.

Repeat 3b and 3c until the output current is within the stated range.

4. Disconnect the test cables and the 10 ohm resistor from monopolar output.
5. To save the current sense gain calibration and go to calibration step 6, turn the Bipolar Power Control knob clockwise.

Next, check the voltage sense gain factor as described in *Calibration Step 6 – Check and adjust the voltage sense gain*.

Calibration Step 6 – Check and Adjust the Voltage Sense Gain

Equipment

- Two short test cables (less than 24 inches long) with banana plugs
- Current transformer (such as the Pearson Model 411 or equivalent)
- True RMS voltmeter (such as the Fluke 8920 or equivalent)
- 750, 3000, and 2000 ohm noninductive power resistors (such as the Dale NH-250)
- Bipolar footswitch and monopolar footswitch

Checking the Voltage Sense Gain for Bipolar Output

Notice

Do not activate the generator with any load resistor lower than 750 ohms while calibrating the voltage sense gain for bipolar output. Otherwise, product damage will result.

1. Verify that the Bipolar display shows calibration step number 6.
The Cut and Coag displays show the V (output voltage) factor. If it is four or more digits, the most significant digits are in the Cut display.
2. Connect the test equipment for bipolar output.
 - a. Connect the two test cables to the Bipolar Instrument receptacle.
 - b. Pass one test cable through the current transformer and connect the current transformer to the voltmeter.

- c. Connect the resistors in series to achieve a 750 ohm load across the output jacks at the end of the test cables.
- d. Connect the bipolar footswitch to the Bipolar Footswitch receptacle on the rear panel.

or

Connect the monopolar footswitch to the Footswitch receptacle on the front panel and press the Footswitch Selector button until the left arrow indicator illuminates green.

- 3. Check and adjust the V factor for bipolar output.
 - a. Press the footswitch pedal and check the voltmeter for a reading equivalent to $0.252 \pm 0.005 A_{rms}$ (0.247 to 0.252 A_{rms}).
 - b. Stop activation. If the output current was not within the stated range, adjust the V factor. Use the Coag Power Control knob for small adjustments and the Cut Power Control knob for larger adjustments.

Approach the value from the low side to give consistent calibration results. Adjust until the current is as close as possible to 0.252 A_{rms} , but not over 0.252 A_{rms} .

Repeat 3a and 3b until the output current is within the stated range.

- 4. Disconnect the test cables and remove the resistors.

Checking the Voltage Sense Gain for Monopolar Output

Notice

Do not activate the generator with any load resistor lower than 3000 ohms while calibrating the voltage sense gain for the pure cut mode. Do not activate the generator with any load resistor lower than 2000 ohms while calibrating the voltage sense gain for the blend mode. Otherwise, product damage will result.

- 1. Connect the test equipment for monopolar output.
 - a. Connect the test cables to the Monopolar Instrument receptacle.
 - b. Connect the resistors in series to achieve a 3000 ohm load. Ensure that one test cable passes through the current transformer.
 - c. Connect a monopolar footswitch to the Monopolar Footswitch receptacle on the rear panel.
- 2. Check and adjust the V factor for the pure mode.
 - a. Press the Pure button.
 - b. Press the footswitch cut pedal and check the voltmeter for a reading equivalent to $0.217 \pm 0.004 A_{rms}$ (0.213 to 0.217 A_{rms}).
 - c. Stop activation. If the output current was not within the stated range, use the Cut and Coag Power Control knobs to adjust the V factor.

Approach the value from the low side. Adjust until the current is as close as possible to 0.217 A_{rms} , but not over 0.217 A_{rms} .

Repeat 2b and 2c until the output current is within the stated range.

3. Replace the 3000 ohm load with the 2000 ohm resistor.
4. Check and adjust the V factor for the blend mode.
 - a. Press the Blend button.
 - b. Press the footswitch cut pedal and check the voltmeter for a reading equivalent to $0.300 \pm 0.006 A_{\text{RMS}}$ (0.294 to 0.300 A_{RMS}).
 - c. Stop activation. If the output current was not within the stated range, use the Cut and Coag Power Control knobs to adjust the V factor.

Approach the value from the low side. Adjust until the current is as close as possible to 0.300 A_{RMS} , but not over 0.300 A_{RMS} .

Repeat 4b and 4c until the output current is within the stated range.

5. Disconnect the test cables and remove the 2000 ohm resistor from monopolar output.
6. To save the voltage sense gain calibration and go to calibration step 7, turn the Bipolar Power Control knob clockwise.

Next, check the reactance gain factor as described in *Calibration Step 7 – Check and adjust the reactance gain*.

Calibration Step 7 – Check and Adjust the Reactance Gain

Equipment

- Two short test cables (less than 24 inches long) with banana plugs
- Current transformer (such as the Pearson Model 411 or equivalent)
- True RMS voltmeter (such as the Fluke 8920 or equivalent)
- 50 and 200 ohm noninductive power resistors (such as the Dale NH-250)
- Bipolar footswitch and monopolar footswitch

Checking the Reactance Gain for Bipolar Output

1. Verify that the Bipolar display shows calibration step number 7.
The Cut and Coag displays show the Z (reactance) factor. If it is four or more digits, the most significant digits appear in the Cut display.
2. Connect the test equipment for bipolar output.
 - a. Connect the two test cables to the Bipolar Instrument receptacle.
 - b. Pass one test cable through the current transformer and connect the current transformer to the voltmeter.

- c. Connect the 50 ohm resistor across the output jacks at the end of the test cables.
- d. Connect the bipolar footswitch to the Bipolar Footswitch receptacle on the rear panel.

or

Connect the monopolar footswitch to the Footswitch receptacle on the front panel and press the Footswitch Selector button until the left arrow indicator illuminates green.

Important

Start with a low Z factor and increase it only until you obtain the desired current. Do not continue to increase it beyond where you first note the correct output current.

3. Adjust the Z factor for bipolar output.
 - a. Press the footswitch pedal and check the voltmeter for a reading equivalent to $1.10 +0/-0.022 A_{\text{rms}}$ (1.078 to 1.100 A_{rms}).
 - b. Stop activation. If the output current was not within the stated range, adjust the Z factor. Use the Coag Power Control knob for small adjustments and the cut knob for larger adjustments.

Start with a low value. Adjust until the current is as close as possible to 1.100 **Arms**, but not over 1.100 **Arms**.

Repeat 3a and 3b until the output current is within the stated range.

4. Disconnect the test cables and remove the 50 ohm resistor.

Checking the Reactance Gain for Monopolar Output

1. Connect the test equipment for monopolar output.
 - a. Connect the test cables to the Monopolar Instrument receptacle.
 - b. Connect the 200 ohm resistor to the test cables through the current transformer.
 - c. Connect a monopolar footswitch to the Monopolar Footswitch receptacle on the rear panel.

Important

Start with a low Z factor and increase it only until you obtain the desired current. Do not continue to increase it beyond where you first note the correct output current.

2. Adjust the Z factor for the pure mode.
 - a. Press the Pure button.
 - b. Press the footswitch cut pedal and check the voltmeter for a reading equivalent to $0.949 +0/-0.019 A_{\text{rms}}$ (0.930 to 0.949 A_{rms}).
 - c. Stop activation. If the output current was not within the stated range, use the Cut and Coag Power Control knobs to adjust the Z factor.

Start with a low value. Adjust until the current is as close as possible to 0.949 A_{rms} , but not over 0.949 A_{rms} .

Repeat 2b and 2c until the output current is within the stated range.

Important

Start with a low Z factor and increase it only until you obtain the desired current. Do not continue to increase it beyond where you first note the correct output current.

3. Adjust the Z factor for the blend mode.
 - a. Press the Blend button.
 - b. Press the footswitch cut pedal and check the voltmeter for a reading equivalent to $1.000 \pm 0.02 A_{\text{rms}}$ (0.98 to 1.00 A_{rms}).
 - c. Stop activation. If the output current was not within the stated range, use the Cut and Coag Power Control knobs to adjust the Z factor.

Start with a low value. Adjust until the current is as close as possible to 1.00 A_{rms} , but not over 1.00 A_{rms} .

Repeat 3b and 3c until the output current is within the stated range.

4. Disconnect the test cables and remove the 200 ohm resistor from monopolar output.
5. To save the reactance gain calibration and go to calibration step 8, turn the Bipolar Power Control knob clockwise.

Next, go to *Calibration Step 8 – Check and adjust the ECON factor*.

Calibration Step 8 – Check and Adjust the ECON Factor

Equipment

- Two short test cables (less than 24 inches long) with banana plugs
- Current transformer (such as the Pearson Model 411 or equivalent)
- True RMS voltmeter (such as the Fluke 8920 or equivalent)
- 30, 100, and 500 ohm noninductive power resistors (such as the Dale NH-250)
- Bipolar footswitch and monopolar footswitch

Checking Bipolar Output

1. Verify that the Bipolar display shows calibration step 8.
2. Connect the test equipment for bipolar output.
 - a. Connect the two test cables to the Bipolar Instrument receptacle.
 - b. Connect the 30 ohm resistor across the output jacks at the end of the test cables.
 - c. Connect the bipolar footswitch to the Bipolar Footswitch receptacle on the rear panel.

or

Connect the monopolar footswitch to the Footswitch receptacle on the front panel and press the Footswitch Selector button until the left arrow indicator illuminates green.

3. Check the bipolar output.
 - a. Verify that the Coag display shows 30 watts.
 - b. Using the bipolar footswitch, activate bipolar output for 2 to 5 seconds.
 - c. Stop activation. Verify that the Coag display changed to 70 watts.
 - d. Activate bipolar output again for 2 to 5 seconds. Stop activation. Verify that the Coag display changed to 30 watts.
4. Disconnect the test cables and remove the 30 ohm resistor.

Checking Monopolar Cut Output

1. Connect the test equipment for monopolar output.
 - a. Connect the test cables to the Monopolar Instrument receptacle.
 - b. Connect the 100 ohm resistor to the test cables.
 - c. Connect a monopolar footswitch to the Monopolar Footswitch receptacle on the rear panel.
2. Check the pure output.
 - a. Press the Pure button.
 - b. Verify that the Coag display shows 30 watts.
 - c. Press the cut pedal to activate monopolar output for 2 to 5 seconds.
 - d. Stop activation. Verify that the Coag display changed to 300.
 - e. Press the cut pedal again for 2 to 5 seconds. Stop activation. Verify that the Coag display changed to 30.
3. Check the blend output.
 - a. Press the Blend button.
 - b. Verify that the Coag display shows 30 watts.
 - c. Press the cut pedal to activate monopolar output for 2 to 5 seconds.
 - d. Stop activation. Verify that the Coag display changed to 200.
 - e. Press the cut pedal again for 2 to 5 seconds. Stop activation. Verify that the Coag display changed to 30.

Checking Monopolar Coag Output

1. Verify that the 100 ohm resistor is connected to the test cables for monopolar output from the Monopolar Instrument receptacle.
2. Check the low 2 and low 3 output.
 - a. Press the Low button.
 - b. Verify that the Cut display shows 2-3, and the Coag display shows 10 watts.
 - c. Press the coag pedal and activate monopolar output for 2 to 5 seconds.
 - d. Stop activation. Verify that the Coag display changed to 300.
 - e. Press the coag pedal again for 2 to 5 seconds. Stop activation. Verify that the Coag display changed to 10.
3. Remove the 100 ohm resistor from the test cables and set up the equipment to check the output current.
 - a. Verify that the test cables are connected to the Monopolar Instrument receptacle.
 - b. Pass one test cable through the current transformer and connect the current transformer to the voltmeter.
 - c. Connect the 500 ohm resistor to the test cables.
4. Press the Low button. Verify that the low mode is selected, the Cut display shows 1, and the Coag display shows 10 watts.
5. Adjust the ECON factor for low 1.
 - a. Press the coag pedal and, while activating the generator, use the Coag Power Control knob to adjust the output current to $0.141 \pm 0.009 A_{\text{rms}}$ (0.132 to 0.150 A_{rms}).
 - b. Stop activation. Verify that the Coag display changed to 120.
 - c. Press the coag pedal again and, while activating the generator, use the Coag Power Control knob to adjust the output current to $0.489 \pm 0.005 A_{\text{rms}}$ (0.484 to 0.494 A_{rms}).
 - d. Stop activation. Verify that the Coag display changed to 10.
6. Press the High button. Verify that the high mode is indicated, the Cut display shows 2, and the Coag display shows 10 watts.

7. Adjust the ECON factor for high 2.
 - a. Press the coag pedal and, while activating the generator, use the Coag Power Control knob to adjust the output current to $0.141 \pm 0.011 A_{\text{rms}}$ (0.130 to 0.141 A_{rms}). Do not exceed 0.141 A_{rms} .
 - b. Stop activation. Verify that the Coag display changed to 120.
 - c. Press the coag pedal again and, while activating the generator, use the Coag Power Control knob to adjust the output current to $0.489 \pm 0.010 A_{\text{rms}}$ (0.479 to 0.489 A_{rms}). Do not exceed 0.489 A_{rms} .
 - d. Stop activation. Verify that the Coag display changed to 10.
8. Press the High button. Verify that the high mode is indicated, the Cut display shows 1, and the Coag display shows 10 watts.
9. Adjust the ECON factor for high 1.
 - a. Press the coag pedal and, while activating the generator, use the Coag Power Control knob to adjust the output current to $0.141 \pm 0.009 A_{\text{rms}}$ (0.132 to 0.150 A_{rms}).
 - b. Stop activation. Verify that the Coag display changed to 120.
 - c. Press the coag pedal again and, while activating the generator, use the Coag Power Control knob to adjust the output current to $0.489 \pm 0.005 A_{\text{rms}}$ (0.484 to 0.494 A_{rms}).
 - d. Stop activation. Verify that the Coag display changed to 10.
10. Remove the 500 ohm resistor and disconnect the test equipment.
11. To save the ECON calibration values, turn the Bipolar Power Control knob clockwise until 9 appears in the Bipolar display.

To leave calibration mode, refer to *Exiting Calibration Mode* in this section.

Troubleshooting

If the generator is not functioning properly, use the information in this section to perform the following tasks:

- Identify and correct the malfunction.
- If a system alarm number was displayed, take the appropriate action to correct the alarm condition.

Inspecting the Generator

If the Force EZ-C Series Electrosurgical Generator malfunctions, check for obvious conditions that may have caused the problem:

- Check the generator for visible signs of physical damage.
- Verify that all accessory cords are properly connected.
- Check the power cord. Replace the power cord if you find exposed wires, cracks, frayed insulation, or a damaged connector.
- Open the fuse drawer and inspect the fuse housing and fuses for damage and corrosion. Verify that the fuses are firmly seated.

An internal component malfunction in the generator can damage the fuses. You may need to replace the fuses if the generator fails the self-test or stops functioning. Refer to Section 8, *Fuses*.

Correcting Malfunctions

If a solution is not readily apparent, use the table below to help identify and correct specific malfunctions. After you correct the malfunction, verify that the generator completes the self-test as described in Section 5.

Situation	Possible Cause	Recommended Action
Generator does not respond when turned on	1. Disconnected power cord, faulty wall receptacle, or faulty power cord	1. Check power cord connections (generator and wall receptacle). Connect the power cord to a functional receptacle. If necessary, replace the power cord.
	2. Fuse drawer is open or fuses are blown	2. Close the fuse drawer. If necessary, replace the fuse(s). Fuses should be 4.0 A (220–240 V operation) or 8.0 A (110-120 V operation). Refer to <i>Fuses</i> in Section 8.
	3. Loose or disconnected internal cables	3. Check all internal connections.
	4. Faulty power entry module or connections	4. Check the power entry module and its cable connections.
	5. Faulty low voltage power supply	5. Check the low voltage power supply.
	6. Damaged Control board connectors and/or malfunctioning Control board	6. Remove the Control board and inspect the connectors to the Power Supply/RF board and to the Display board for damage, poor seating, etc. If the problem persists, replace the Control board. For instructions, refer to <i>Control Board</i> in Section 8.
	7. Shorts or disconnects on Power Supply/RF board	7. Check the Power Supply/RF board for shorts or disconnects.
	8. Faulty power switch	8. Replace the power switch. Refer to <i>Front Panel Power Switch</i> in Section 8.
	9. Malfunctioning front panel components	9. Replace the front panel assembly. Refer to <i>Front Panel</i> in Section 8.

Situation	Possible Cause	Recommended Action
Generator is on, but did not complete the self-test	1. Software malfunction	1. Turn off, then turn on the generator.
	2. Loose or disconnected internal cables	2. Check and correct all internal connections.
	3. Faulty low voltage power supply	3. Check the low voltage power supply.
	4. Damaged Control board connectors and/or malfunctioning Control board	4. Remove the Control board and inspect the connectors to the Power Supply/RF board and to the Display board for damage, poor seating, etc. If the problem persists, replace the Control board. For instructions, refer to <i>Control Board</i> in Section 8.
	5. Shorts or disconnects on Power Supply/RF board	5. Check the Power Supply/RF board for shorts or disconnects.
	6. Malfunctioning front panel components	6. Replace the front panel assembly. Refer to <i>Front Panel</i> in Section 8.
Alarm number 212 appears in the Cut display during the self-test	1. The battery was removed and/or replaced, but the generator was not calibrated.	1. Turn off, then turn on the generator to clear the number. Calibrate the generator. For instructions, refer to <i>Calibrating the Force EZ-C Series Electrosurgical Generator</i> in Section 5.
	2. Faulty battery on Control board causing loss of battery-backed memory	2. Replace the battery and check the battery-backed RAM device. Refer to <i>Correcting Battery-Backed RAM Malfunctions</i> later in this section.
	3. Loss of battery-backed RAM due to faulty component on the Control board (other than the battery)	3. Replace the Control board. Refer to <i>Control Board</i> in Section 8.
Activation and/or alarm tones do not sound; speaker is malfunctioning	1. Poor connection or damaged Footswitch board ribbon cable	1. Check/correct connection. If indicated, replace the Footswitch board. Refer to <i>Footswitch Board</i> in Section 8.
	2. Faulty connections or speaker on Footswitch board	2. Replace the Footswitch board. Refer to <i>Footswitch Board</i> in Section 8.
	3. Audio signal malfunction on Control board	3. Replace the Control board. Refer to <i>Control Board</i> in Section 8.
	4. Audio circuitry malfunction on Power Supply/RF board	4. Troubleshoot Power Supply/RF board components, particularly U8 and associated components.

Situation	Possible Cause	Recommended Action
Blank or confusing LED display	1. Faulty ribbon cable between Control board and Display board	1. Check/connect ribbon cable that connects the Display board to the Control board.
	2. Incorrect display modes communicated through the Control board	2. Replace the Control board. Refer to <i>Control Board</i> in Section 8.
	3. Display board malfunction	3. Replace the Display board. Refer to <i>Display Board</i> in Section 8.
Mode buttons do not function correctly when pressed	1. Faulty ribbon cable between Control board and Display board	1. Check/connect ribbon cable that connects the Display board to the Control board.
	2. Incorrect modes communicated through the Control board	2. Replace the Control board. Refer to <i>Control Board</i> in Section 8.
	3. Display board malfunction	3. Replace the Display board. Refer to <i>Display Board</i> in Section 8.
Footswitch connected to Footswitch receptacle on front panel is not functioning correctly	1. Front panel footswitch provides output only to Accessory Instrument receptacle and you want output to the Monopolar Instrument receptacle	1. Connect the footswitching instrument to the Accessory Instrument receptacle. To use a footswitch for the Monopolar Instrument receptacle, connect the footswitch to the rear panel.
	2. Footswitch Selector button is set to incorrect output	2. Press the Footswitch Selector button to illuminate the arrow indicator for the desired instrument receptacle: the left arrow indicator illuminates for the Bipolar Instrument receptacle; the right arrow indicator illuminates for the Accessory Instrument receptacle.
	3. Damaged front panel footswitch receptacle	3. Replace the front panel footswitch receptacle. Refer to <i>Front Panel Footswitch Receptacle</i> in Section 8.
	4. Control board is losing or not processing signal	4. Replace the Control board. Refer to <i>Control Board</i> in Section 8.
	5. Circuitry malfunction on Display board or faulty ribbon cable	5. Replace the Display board (including the ribbon cable). Refer to <i>Display Board</i> in Section 8.

Situation	Possible Cause	Recommended Action
Rear panel footswitch will not activate output	1. Rear panel monopolar footswitch activates only handswitching instrument connected to Monopolar Instrument receptacle	1. Use a handswitching instrument or connect the footswitching instrument to a universal adapter. Then connect the adapter to the Monopolar Instrument receptacle for handswitching output.
	2. Faulty connection from Footswitch board to Power Supply/RF board	2. Check the ribbon cable and its connections.
	3. Malfunctioning or damaged rear panel footswitch receptacle	3. Replace the Footswitch board. Refer to <i>Footswitch Board</i> in Section 8.
	4. Footswitch activation signal lost on Control board	4. Replace the Control board. Refer to <i>Control Board</i> in Section 8.
	5. Malfunctioning footswitch interface circuitry on Power Supply/RF board	5. Troubleshoot components on the Power Supply/RF board: <ul style="list-style-type: none"> • Check the DC/DC converter (U11). • Check optical isolators ISO1, ISO2, and ISO3.

Situation	Possible Cause	Recommended Action
Generator is on and accessory is activated, but generator does not deliver output	1. Malfunctioning footswitch or handswitching instrument	1. Turn off the generator. Check and correct all accessory connections. Turn on the generator. Replace the accessory if it continues to malfunction.
	2. Incompatible footswitch	2. Use only a Valleylab monopolar footswitch with the Force EZ-C Series Electrosurgical Generator.
	3. Footswitch is connected to front panel Footswitch receptacle, but arrow indicator at Footswitch Selector button does not indicate desired instrument receptacle	3. Verify all accessory connections. Press the Footswitch Selector button to illuminate the arrow indicator for the desired instrument receptacle: the left arrow indicator illuminates for the Bipolar Instrument receptacle; the right arrow indicator illuminates for the Accessory Instrument receptacle.
	4. Footswitch connected to front panel Footswitch receptacle is being used for instrument connected to Monopolar Instrument receptacle	4. Connect the footswitch to the rear panel Monopolar Footswitch receptacle. or If you are using a footswitching instrument, connect it to the Accessory receptacle.
	5. Footswitch connected to rear panel Monopolar Footswitch receptacle is being used for instrument connected to Accessory Instrument receptacle	5. Connect the footswitch to the front panel Footswitch receptacle or Connect the instrument to the Monopolar Instrument receptacle.
	6. Power set too low	6. Increase the power setting.
	7. An alarm condition exists	7. Check the Cut display for an alarm number. Note the number and refer to <i>Responding to System Alarms</i> later in this section.
	8. Control board malfunction	8. If the activation bar does not illuminate and the tone does not sound, replace the Control board. Refer to <i>Control Board</i> in Section 8. If the activation bar illuminates and the tone sounds, the malfunction is likely to be on the Power Supply/RF board.
	9. Blown fuse on Power Supply/RF board	9. Check the high voltage power supply fuse (F1) and replace if necessary. Refer to <i>Fuses</i> in Section 8

Situation	Possible Cause	Recommended Action
<p>Generator is on and accessory is activated, but generator does not deliver output - <i>continued</i></p>	<p>10. High voltage power supply malfunction (high voltage is not present during activation)</p>	<p>10. If high voltage is not present during activation at TP20 on the Power Supply RF/Board, troubleshoot the high voltage power supply as described below:</p> <p>Check the voltages after bridge rectifier CR80 and line filter capacitors at TP10, TP13, and TP14.</p> <p>Check switching transistors (Q2, Q4, Q5, and Q7) for failure (typically fail shorted) at TP7, TP11, TP18, and TP19 to respective drain and source pins.</p> <p>Check high voltage rectifiers CR17, CR22, CR23, CR36.</p> <p>Troubleshoot the pulse-width modulator circuit (U3 and surrounding components).</p> <p>Check SYS_ECON circuit from TP3 to U3.</p> <p>Perform further detailed component troubleshooting as needed.</p>
	<p>11. RF output stage malfunction (high voltage is present during activation)</p>	<p>11. If high voltage is present during activation at TP20 on the Power Supply RF/Board, troubleshoot the generator as described below:</p> <p>On the Power Supply/RF board, verify T_ON\ pulses during activation at U22 (TP33).</p> <p>If pulses are not present at TP33, replace the Control board. Refer to <i>Control Board</i> in Section 8.</p> <p>If pulses are present at TP33, but are not present after U22, replace U22.</p> <p>On the right heat sink, check the power MOSFET at J13 for failure (typically fail shorted).</p> <p>Check all output relays to verify that they are toggling during activation. The problem could be on the Control board at the relay driver (U16) or K10, K11, K12, K13, or K14.</p> <p>Perform further detailed component troubleshooting as needed. Check for shorting of the output tuning inductors (L2 and L3) and failure of the output tuning capacitors C143, C154, C159, C165, C166, etc.</p>

Situation	Possible Cause	Recommended Action
Continuous monitor interference	1. Faulty chassis-to-ground connections	1. Check and correct the chassis ground connections for the monitor and, if applicable, for the generator. Check other electrical equipment in the room for defective grounds.
	2. Electrical equipment is grounded to different objects rather than a common ground. The generator may respond to the resulting voltage differences between grounded objects.	2. Plug all electrical equipment into line power at the same location.
	3. Malfunctioning monitor	3. Replace the monitor.
Interference with other devices only when generator is activated	1. Metal-to-metal sparking	1. Check all connections to the generator, patient return electrode, and accessories.
	2. High settings used for fulguration	2. Use lower power settings for fulguration or select the low (desiccate) mode.
	3. Electrically inconsistent ground wires in the operating room	3. Verify that all ground wires are as short as possible and go to the same grounded metal.
	4. If interference continues when the generator is activated, the monitor is responding to radiated frequencies.	4. Check with the manufacturer of the monitor. Some manufacturers offer RF choke filters for use in monitor leads. The filters reduce interference when the generator is activated and minimize the potential for an electrosurgical burn at the site of the monitor electrode.

Situation	Possible Cause	Recommended Action
Pacemaker interference.	<ol style="list-style-type: none"> Intermittent connections or metal-to-metal sparking 	<ol style="list-style-type: none"> Check all connections to the generator. It may be necessary to reprogram the pacemaker.
	<ol style="list-style-type: none"> Current traveling from active to return electrode during monopolar electrosurgery is passing too close to pacemaker. 	<ol style="list-style-type: none"> Use bipolar instruments, if possible. If you must use a monopolar instrument, place the patient return electrode as close as possible to the surgical site. Make sure the current path from the surgical site to the patient return electrode does not pass through the vicinity of the heart or the site where the pacemaker is implanted. Always monitor patients with pacemakers during surgery and keep a defibrillator available. Consult the pacemaker manufacturer or hospital Cardiology Department for further information when use of electrosurgical appliances is planned in patients with cardiac pacemakers.
Abnormal neuromuscular stimulation (stop surgery immediately)	<ol style="list-style-type: none"> Metal-to-metal sparking 	<ol style="list-style-type: none"> Check all connections to the generator, patient return electrode, and active electrodes.
	<ol style="list-style-type: none"> Can occur during coag. It is more likely when using the low 1 or high settings than when cutting, and is unlikely when using the low 2 or low 3 setting. 	<ol style="list-style-type: none"> Use a lower power setting for the low 1 and high settings or select the low 2 or low 3 setting.
	<ol style="list-style-type: none"> Abnormal 50-60 Hz leakage currents 	<ol style="list-style-type: none"> Inside the generator, carefully inspect for damage that may cause shorting between the AC line voltage and connected patient components.

Responding to System Alarms

When a system alarm condition exists, an alarm tone sounds and a number flashes in the Cut display. The generator is disabled until the condition is cleared.

Most system alarms require some action on your part to correct the condition; however, some are corrected automatically. Use the following table to determine how to correct an alarm condition.

After correcting the alarm condition, verify that the generator completes the self-test as described in Section 5.

Number	Description	Recommended Action
0	Master microcontroller failed to hold feedback microcontroller in reset.	Turn the power switch off (O) then on (I) again. If error reappears, replace the control board. Refer to <i>Control Board Replacement</i> in Section 8.
1	Master microcontroller failed to power up feedback microcontroller	
2	Feedback microcontroller failed to power up and initialize RAM in time allotted.	
3	Feedback microcontroller failed to checksum battery-backed RAM data in dual-port RAM in time allotted.	Turn the power switch off (O) then on (I) again. If error reappears, replace the control board. Refer to <i>Control Board Replacement</i> in Section 8.
4	Internal diagnostics. Master microcontroller CPU test failed.	
5	Master microcontroller unable to access FEEDBACK_SEM semaphore.	
6	Master microcontroller unable to access ECON_SEM semaphore.	
7	Master microcontroller unable to access KEY_ACTIVE_SEM semaphore.	1. Replace the Control board. Refer to <i>Control Board</i> in Section 8. 2. Calibrate the generator. Refer to Section 6 for instruction. If the alarm number appears, record the number and call the Valleylab Service Center.
10	Software malfunction. Invalid alarm number.	
11	Internal diagnostics. Invalid activated power, function, mode, or key request mode echoed by feedback microcontroller.	Turn off, then turn on the generator. If the alarm number reappears, record the number and call the Valleylab Service Center.
12	Diagnostics/microcontroller malfunction. TON_ERR test failed.	Turn the power switch off (O) then on (I) again. If error reappears, replace the control board. Refer to <i>Control Board Replacement</i> in Section 8.
		Refer to <i>Correcting T_ON ASIC Malfunctions</i> (steps 4–11) in this section. If error reappears, replace the control board. Refer to <i>Control Board Replacement</i> in Section 8.

Number	Description	Recommended Action
13	Master microcontroller unable to access GEN_SEM semaphore.	Turn the power switch off (O) then on (I) again. If error reappears, replace the control board. Refer to <i>Control Board Replacement</i> in Section 8.
14	Internal diagnostics. Calibration data checksum error on master microcontroller.	Turn the power switch off (O) then on (I) again. If error reappears, replace the control board. Refer to <i>Control Board Replacement</i> in Section 8.
16	Diagnostics/microcontroller malfunction. T_ON average test failed.	Calibrate the ECON factor (refer to Section 5 for instructions). If the alarm number reappears, refer <i>Correcting T_ON ASIC Malfunctions</i> in this section.
17	Isns and/or Vsns voltage detected without activation.	Do not attempt to use the generator. Record the number and call the Valleylab Service Center.
18	REM circuit failure. REM oscillator frequency outside acceptable operating range.	
19	Overvoltage detected on +5V power supply.	
30	Software malfunction. audio_state value outside state range.	Turn off, then turn on the generator. If the alarm number reappears, record the number and call the Valleylab Service Center.
31	Software malfunction. Invalid alarm number.	
32	Software malfunction. alarm_state value outside state range.	
40	Software malfunction. selection_state [button_num] value outside state range.	
50	Software malfunction. encoder_state [which_encoder] value outside state range.	
51	Software malfunction. which_encoder value outside state range.	
54	Software malfunction. user_mode_index value outside state range.	

Number	Description	Recommended Action
55	Software malfunction. user_flash_off value outside state range.	Turn off, then turn on the generator. If the alarm number reappears, record the number and call the Valleylab Service Center.
57	Software malfunction. Low_mode or High_mode value outside state range.	
58	Software malfunction. Settings[COAG].mode_setting value outside state range.	
59	Software malfunction. start_coag_mode value outside state range.	
60	Software malfunction. which_display value outside state range.	
61	Software malfunction. which_func value outside state range.	
62	Software malfunction. Key_req_mode value outside state range.	
63	Software malfunction. direction value outside state range.	
64	Software malfunction. msg.action_code value outside state range.	
65	Software malfunction. flash_state value outside state range.	
66	Software malfunction. Unable to find alarm number to display.	
67	Internal diagnostics. Settings data corrupted.	
68	Master microcontroller unable to access GEN_SEM semaphore.	
69	Software malfunction. temp_hi_state value outside state range.	Turn off, then turn on the generator. If the alarm number reappears, record the number and call the Valleylab Service Center.
70	Software malfunction. key_req_mode value outside state range.	
71	Software malfunction. request+1 value outside state range.	
80	Software malfunction. *input[i].p_state value outside state range.	
81	Internal component malfunction. Optoisolator test failed.	Do not attempt to use the generator. Record the number and call the Valleylab Service Center.

Number	Description	Recommended Action
90	Generator model number in master microcontroller Flash Memory not Force EZ-C Series Electrosurgical Generator model number.	Turn the power switch off (O) then on (I) again. If error reappears, replace the control board. Refer to <i>Control Board Replacement</i> in Section 8.
95	Generator model number in feedback microcontroller Flash Memory not Force EZ-C Series Electrosurgical Generator model number.	
100	Software malfunction. rem_update_state value outside state range.	Turn off, then turn on the generator. If the alarm number reappears, record the number and call the Valleylab Service Center.
101	Software malfunction. rem_pad_state value outside state range.	
102	Software malfunction. rem_state value in re_rem_control() outside state range.	
103	Software malfunction. rem_state value in re_non_rem_control() outside state range.	
104	Software malfunction. rem_flash_state value outside state range.	
105	Software malfunction. rem_led_state value outside state range.	
109	Software malfunction. coag_state value in ca_econ_cal() outside state range.	
110	Software malfunction. cal_state value in ca_generator_setup() outside state range.	
111	Software malfunction. cal_state value in ca_clock_date_setup() outside state range.	
112	Software malfunction. cal_mode value in ca_clock_date_setup() outside state range.	
113	Software malfunction. cal_state value in ca_clock_time_setup() outside state range.	
114	Software malfunction. cal_mode value in ca_clock_time_setup() outside state range.	
115	Software malfunction. cal_state value in ca_coag_leakage_cal() outside state range.	
116	Software malfunction. cal_state value in ca_econ_cal() outside state range.	

Number	Description	Recommended Action
117	Software malfunction. econ_cal_state value outside state range.	Turn off, then turn on the generator. If the alarm number reappears, record the number and call the Valleylab Service Center.
118	Software malfunction. cal_state value in ca_rem_cal() outside state range.	
119	Software malfunction. rem_cal_state value outside state range.	
120	Calibration malfunction. Calibration value(s) outside acceptable range.	Repeat the failing calibration step. If the alarm number reappears, record the number and call the Valleylab Service Center.
121	Software malfunction. cal_mode value in ca_generator_setup() outside state range.	Turn off, then turn on the generator. If the alarm number reappears, record the number and call the Valleylab Service Center.
122	Open circuit REM sense failure.	Repeat the failing calibration step. If the alarm number reappears, record the number and call the Valleylab Service Center.
123	Master microcontroller unable to access GEN_SEM semaphore.	Turn the power switch off (O) then on (I) again. If error reappears, replace the control board. Refer to <i>Control Board Replacement</i> in Section 8.
124	Master microcontroller unable to access FEEDBACK_SEM semaphore.	
125	Master microcontroller unable to access ECON_SEM semaphore.	
126	Master microcontroller unable to access KEY_ACTIVE_SEM semaphore.	
127	REM circuit malfunction. REM oscillator frequency cannot be set to 100 kHz.	Do not attempt to use the generator. Record the number and call the Valleylab Service Center.
128	REM circuit malfunction. REM oscillator frequency cannot be set within operating range.	
129	Software malfunction. rem_cal_pot_state value outside state range.	Turn off, then turn on the generator. If the alarm number reappears, record the number and call the Valleylab Service Center.
130	Software malfunction. convert_this value outside state range.	

Number	Description	Recommended Action
131	Software malfunction. Settings[COAG].mode_setting value in cd_update_date() outside state range.	Turn off, then turn on the generator. If the alarm number reappears, record the number and call the Valleylab Service Center.
132	Software malfunction. Settings[COAG].mode_setting value in cd_update_time() outside state range.	
133	Software malfunction. cal_settings.cal_value value in cd_rem_value_conversion() outside state range.	
134	Software malfunction. cal_step value outside state range.	
135	Software malfunction. Settings[button_function].mode_setting and cd_write_to_display outside state range.	
136	Software malfunction. button_function value outside state range.	
137	Software malfunction. which_display value outside state range.	
138	Software malfunction. update_this value outside state range.	
139	Software malfunction. value_displayed value in cd_update_date() outside state range.	
140	Software malfunction. value_displayed value in cd_update_time() outside state range.	
150	Software malfunction. cal_state value in cs_v_sns_cal() outside state range.	
151	Master microcontroller unable to access GEN_SEM semaphore.	Turn the power switch off (O) then on (I) again. If error reappears, replace the control board. Refer to <i>Control Board Replacement</i> in Section 8.
152	Software malfunction. cal_state value in cs_i_sns_cal() or cs_react_cal() outside state range.	Turn off, then turn on the generator. If the alarm number reappears, record the number and call the Valleylab Service Center.
154	Master microcontroller unable to access FEEDBACK_SEM semaphore.	Turn the power switch off (O) then on (I) again. If error reappears, replace the control board. Refer to <i>Control Board Replacement</i> in Section 8.
159	High voltage power supply is below expected output level.	Record the alarm number and call the Valleylab Service Center.
160	Internal component malfunction. Dosage error test failed. ADC values display at failure.	Calibrate the ECON factor. Refer to Section 6 for instructions. If the alarm number reappears, refer to <i>Correcting T_ON ASIC Malfunctions</i> in this section.

Number	Description	Recommended Action
161	Dosage error while generator was activated, where Vsns and Isns stay the same or decrease while the ECON increases consistently for about 150 ms.	Do not attempt to use the generator. Record the number and call the Valleylab Service Center.
163	Dosage error while activating the low 1 coag setting or either of the two high coag settings.	
164	Dosage error detected for actual current values while activating the bipolar mode, a cut mode, or the low 2 or low 3 coag setting.	If the error occurs during calibration, repeat the failing calibration step. If the number reappears, record the number and call the Valleylab Service Center.
165	Dosage error detected for actual power values while activating the bipolar mode, a cut mode, or the low 2 or low 3 coag setting.	or If the error occurs during normal use, do not attempt to use the generator. Record the number and call the Valleylab Service Center.
166	Dosage error detected for actual voltage values while activating a cut mode, or the low 2 or low 3 coag setting.	
170	Watchdog malfunction. Correct value not sent from feedback microcontroller.	Turn the power switch off (O) then on (I) again. If error reappears, replace the control board. Refer to <i>Control Board Replacement</i> in Section 8.
171	Watchdog malfunction. Correct value not sent from master microcontroller.	Turn the power switch off (O) then on (I) again. If error reappears, replace the control board. Refer to <i>Control Board Replacement</i> in Section 8.
172	Watchdog malfunction. Master microcontroller unable to access watchdog semaphore.	
173	Watchdog malfunction. Feedback microcontroller unable to access watchdog semaphore.	Turn the power switch off (O) then on (I) again. If error reappears, replace the control board. Refer to <i>Control Board Replacement</i> in Section 8.
174	Software malfunction. which_errors value outside state range.	Turn off, then turn on the generator. If the alarm number reappears, record the number and call the Valleylab Service Center.
180	Internal diagnostics. Master microcontroller ST Microelectronics RAM check failed.	Turn the power switch off (O) then on (I) again. If error reappears, replace the control board. Refer to <i>Control Board Replacement</i> in Section 8.
181	Internal diagnostics. Feedback microcontroller ST Microelectronics RAM check failed.	Turn the power switch off (O) then on (I) again. If error reappears, replace the control board. Refer to <i>Control Board Replacement</i> in Section 8.
182	Internal diagnostics. Master microcontroller dual-port RAM check failed.	Turn the power switch off (O) then on (I) again. If error reappears, replace the control board. Refer to <i>Control Board Replacement</i> in Section 8.
183	Internal diagnostics. Master microcontroller Page 0 (zero) Flash Memory CRC test failed.	

Number	Description	Recommended Action
184	Internal diagnostics. Master microcontroller Page F Flash Memory CRC test failed.	Turn the power switch off (O) then on (I) again. If error reappears, replace the control board. Refer to <i>Control Board Replacement</i> in Section 8.
185	Internal diagnostics. Feedback microcontroller Flash Memory CRC test failed.	Turn the power switch off (O) then on (I) again. If error reappears, replace the control board. Refer to <i>Control Board Replacement</i> in Section 8.
189	Software malfunction. display_state value outside state range.	Turn off, then turn on the generator. If the alarm number reappears, record the number and call the Valleylab Service Center.
191	Internal diagnostics. Cut mode buttons (Pure and/or Blend) may be stuck.	<ol style="list-style-type: none"> 1. Turn off, then turn on the generator Do not press buttons or accessory activation devices during the self-test. 2. If the alarm number reappears, disconnect all accessories. Turn off, then turn on the generator again. <p>If the alarm number reappears, record the number and call the Valleylab Service Center.</p>
192	Internal diagnostics. Coag mode buttons (High and/or Low) may be stuck.	
193	Internal diagnostics. Front panel Footswitch Selector button may be stuck.	
194	Internal diagnostics. Handswitch or cut pedal may be stuck.	
195	Internal diagnostics. Handswitch or coag pedal may be stuck.	
196	Internal diagnostics. Handswitch or cut key may be stuck.	
197	Internal diagnostics. Handswitch or coag key may be stuck.	
198	Internal diagnostics. Handswitch or bipolar footswitch pedal may be stuck.	
199	Internal diagnostics. Master and feedback microcontrollers are not compatible.	Turn the power switch off (O) then on (I) again. If error reappears, replace the control board. Refer to <i>Control Board Replacement</i> in Section 8.
200	Internal diagnostics. Master microcontroller SEML line may be stuck.	<ol style="list-style-type: none"> 1. Replace the Control board. Refer to <i>Control Board</i> in Section 8 for instructions. 2. Calibrate the generator. Refer to Section 6 for instructions. <p>If the alarm number reappears, record the number and call the Valleylab Service Center.</p>
201	Internal diagnostics. Feedback microcontroller SEMR line may be stuck.	
202	Internal diagnostics. Master microcontroller watchdog test failed.	Turn the power switch off (O) then on (I) again. If error reappears, replace the control board. Refer to <i>Control Board Replacement</i> in Section 8.
203	Internal diagnostics. Feedback microcontroller watchdog test failed.	Turn the power switch off (O) then on (I) again. If error reappears, replace the control board. Refer to <i>Control Board Replacement</i> in Section 8.

Number	Description	Recommended Action
206	Software malfunction. doserr_test_state value in st_m_doserr_test outside state range.	Turn off, then turn on the generator. If the alarm number reappears, record the number and call the Valleylab Service Center.
207	Software malfunction. doserr_test_state value in st_fb_doserr_test outside state range.	
208	Master microcontroller timer interrupt failed.	<ol style="list-style-type: none"> 1. Replace the Control board. Refer to <i>Control Board</i> in Section 8. 2. Calibrate the generator. Refer to Section 6 for instructions. <p>If the alarm number reappears, record the number and call the Valleylab Service Center.</p>
209	Feedback microcontroller timer interrupt failed.	
210	Software malfunction. data_type value outside state range.	Turn off, then turn on the generator. If the alarm number reappears, record the number and call the Valleylab Service Center.
211	Software malfunction. which_data value outside state range.	
212	Generator not calibrated.	Refer to <i>Correcting Battery-Backed RAM Malfunctions</i> in this section.
213	Internal diagnostics. Firmware not compatible with hardware.	Turn the power switch off (O) then on (I) again. If error reappears, replace the control board. Refer to <i>Control Board Replacement</i> in Section 8.
214	REM circuit malfunction. REM oscillator frequency cannot be set to calibrated frequency.	Do not attempt to use the generator. Record the number and call the Valleylab Service Center.
215	Internal diagnostics. Real-time clock chip not compatible with firmware.	<ol style="list-style-type: none"> 1. Replace the Control board. Refer to <i>Control Board</i> in Section 8. 2. Calibrate the generator. Refer to Section 6 for instructions. <p>If the alarm number reappears, record the number and call the Valleylab Service Center.</p>
216	Internal diagnostics. 3V button-cell battery exhausted.	Refer to <i>Battery</i> in Section 8.
220	Feedback microcontroller unable to access KEY_REQ_SEM semaphore.	Turn the power switch off (O) then on (I) again. If error reappears, replace the control board. Refer to <i>Control Board Replacement</i> in Section 8.
221	Feedback microcontroller unable to access GEN_SEM semaphore.	
223	Master microcontroller failed to complete initialization in time allotted.	Turn the power switch off (O) then on (I) again. If error reappears, replace the control board. Refer to <i>Control Board Replacement</i> in Section 8.

Number	Description	Recommended Action
224	Internal diagnostics. Calibration data checksum error on feedback microcontroller.	Turn the power switch off (O) then on (I) again. If error reappears, replace the control board. Refer to <i>Control Board Replacement</i> in Section 8.
225	Internal diagnostics. Feedback microcontroller CPU test failed.	<ol style="list-style-type: none"> 1. Replace the Control board. Refer to <i>Control Board</i> in Section 8. 2. Calibrate the generator. Refer to Section 6 for instructions. <p>If the alarm number reappears, record the number and call the Valleylab Service Center.</p>
226	Feedback microcontroller unable to access FEEDBACK_SEM semaphore.	Turn the power switch off (O) then on (I) again. If error reappears, replace the control board. Refer to <i>Control Board Replacement</i> in Section 8.
230	Software malfunction. keyed_state value outside state range.	Turn off, then turn on the generator. If the alarm number reappears, record the number and call the Valleylab Service Center.
231	Software malfunction. Key_req_mode value outside state range.	
232	Feedback microcontroller unable to access KEY_ACTIVE_SEM semaphore.	Turn the power switch off (O) then on (I) again. If error reappears, replace the control board. Refer to <i>Control Board Replacement</i> in Section 8.
233	Software malfunction. Low_mode or High_mode value in ac_calc_desired_vals() outside state range.	Turn off, then turn on the generator. If the alarm number reappears, record the number and call the Valleylab Service Center.
240	Software malfunction. activation_seq value outside state range.	
241	Software malfunction. Feedback value in do_cut_feedback outside state range.	
242	Software malfunction. feedback value in do_cal_feedback() outside state range.	
244	Software malfunction. disable_seq value outside state range.	
245	Software malfunction. spark_state value outside state range.	
246	Feedback microcontroller unable to access FEEDBACK_SEM semaphore.	
247	Feedback microcontroller unable to access ECON_SEM semaphore.	

Number	Description	Recommended Action
260	Internal diagnostics. A/D conversion did not complete in allowed time.	<ol style="list-style-type: none"> 1. Replace the Control board. Refer to <i>Control Board</i> in Section 8. 2. Calibrate the generator. Refer to Section 6 for instructions. <p>If the alarm number reappears, record the number and call the Valleylab Service Center.</p>
261	Software malfunction. Delay time out of bounds on master microcontroller.	Turn off, then turn on the generator. If the alarm number reappears, record the number and call the Valleylab Service Center.
262	Software malfunction. Delay time out of bounds on feedback controller.	
270	Software malfunction. data_type in me_rtc_get() outside of range.	
271	Software malfunction. data_type in me_rtc_put() outside of range.	
451	The internal temperature limit was exceeded due to length of activation time.	<p>Verify that the location of the generator allows for adequate cooling.</p> <p>Use the lowest power setting that achieves the desired effect. Limit activation times, if possible.</p>

Correcting Integrated Circuit (IC) Malfunctions

The recommended action for correcting some alarm conditions includes correcting integrated circuit (IC) malfunctions:

- ASIC T_ON
- Battery-backed RAM

Correcting T_ON ASIC Malfunctions

Equipment:

- Phillips screwdriver
- Surface mount, quad pack chip extractor

Warning

Electric Shock Hazard – To allow stored energy to dissipate after disconnecting power, wait at least five minutes before replacing parts.

Electric Shock Hazard – Do not touch any exposed wiring or conductive surfaces while the generator is disassembled and energized. Never wear a grounding strap when working on an energized generator.

Caution

The generator contains electrostatic-sensitive components. When repairing the generator, work at a static-control workstation. Wear a grounding strap when handling electrostatic-sensitive components, **except** when working on an energized generator. Handle circuit boards by their nonconductive edges. Use an antistatic container for transport of electrostatic-sensitive components and circuit boards.

Procedure

1. Turn off the generator and disconnect the power cord from the wall receptacle.
2. Loosen the four screws that secure the cover to the chassis. Lift the cover off the chassis.
3. Remove the Control board.
 - a. Remove the screw that secures the retention bracket to the left rear heat sink.
 - b. Unlock the connector on the Control board and disconnect the Display board ribbon cable from the Control board.
 - c. Carefully slide the Control board straight up to disconnect it from the Power Supply/RF board.
4. On the Control board, verify that the pins on programmable IC U9 are properly seated in their socket.
 - a. Grip IC U9 with the chip extractor and lift it out of its socket.
 - b. Align the notch on IC U9 above the notch on the socket and gently press the chip back into the socket.

5. Reinstall the Control board.
 - a. Position the Control board over the Power Supply/RF board, fitting the edge of the board into the slot on the right heat sink. Slide the board down, carefully fitting the edge connector into the matching connector on the Power Supply/RF board.
 - b. Place the retention bracket on the left rear heat sink and install the screw that secures the bracket to the heat sink.
 - c. Connect the Display board ribbon cable to the Control board and lock the connector.
6. Turn on the generator. If the generator successfully completes the self-test, reinstall the cover (step 11).
7. If the alarm number reappears, replace programmable IC U9.
 - a. Turn off the generator.
 - b. Remove the Control board (step 3).
 - c. Grip IC U9 with the chip extractor and lift it out of its socket.
 - d. Align the notch on the new chip above the notch on the socket and gently press the chip into the socket.
 - e. Reinstall the Control board (step 5).
8. Turn on the generator. If the generator successfully completes the self-test, reinstall the cover (step 11).
9. If the alarm number reappears, replace the Control board.
 - a. Turn off the generator.
 - b. Remove the Control board (step 3).
 - c. Install the new Control board (step 5).
10. Calibrate the generator. Refer to Section 6 for instructions. If the alarm number reappears, record the number and call the Valleylab Service Center.
11. To reinstall the cover, position the cover above the chassis and slide it down. Tighten the four screws that secure the cover to the chassis.

Correcting Battery-Backed RAM Malfunctions

Equipment:

- Phillips screwdriver
- Surface mount, quad pack chip extractor

Warning

Electric Shock Hazard – To allow stored energy to dissipate after disconnecting power, wait at least five minutes before replacing parts.

Electric Shock Hazard – Do not touch any exposed wiring or conductive surfaces while the generator is disassembled and energized. Never wear a grounding strap when working on an energized generator.

Caution

The generator contains electrostatic-sensitive components. When repairing the generator, work at a static-control workstation. Wear a grounding strap when handling electrostatic-sensitive components, **except** when working on an energized generator. Handle circuit boards by their nonconductive edges. Use an antistatic container for transport of electrostatic-sensitive components and circuit boards.

Procedure

1. Turn off the generator and disconnect the power cord from the wall receptacle.
2. Loosen the four screws that secure the cover to the chassis. Lift the cover off the chassis.
3. Remove the Control board.
 - a. Remove the screw that secures the retention bracket to the left rear heat sink.
 - b. Unlock the connector on the Control board and disconnect the Display board ribbon cable from the Control board.
 - c. Carefully slide the Control board straight up to disconnect it from the Power Supply/RF board.
4. Replace the battery.
 - a. Grasp the battery and snap it out of the socket.
 - b. Position the new 3 V button-cell battery so that the positive side of the battery is facing out (visible). Refer to *Control board Components* in Section 9 for the Valleylab replacement battery or call the Valleylab Service Center for information about approved battery replacements.
 - c. Snap the new battery into the socket so it is firmly seated.

Important

Internal memory loses all stored data (refer to Section 4, Internal Memory) when you remove the battery .

5. Reinstall the Control board.
 - a. Position the Control board over the Power Supply/RF board, fitting the edge of the board into the slot on the right heat sink. Slide the board down, carefully fitting the edge connector into the matching connector on the Power Supply/RF board.
 - b. Place the retention bracket on the left rear heat sink and install the screw that secures the bracket to the heat sink.
 - c. Connect the Display board ribbon cable to the Control board and lock the connector.
6. Calibrate the generator. Refer to Section 6 for instructions. If the calibration is successful, reinstall the cover (step 12).
7. If the alarm number reappears, replace the Control board.
 - a. Turn off the generator.
 - b. Remove the Control board (step 3).
 - c. Install the new Control board (step 6).
8. Recalibrate the generator. If the alarm number reappears, record the number and call the Valleylab Service Center.
9. To reinstall the cover, position the cover above the chassis and slide it down. Tighten the four screws that secure the cover to the chassis.



Replacement Procedures

Use the procedures in this section when you need to replace the following parts:

- Battery for battery-backed RAM
- Control board
- Display board and seven-segment LEDs
- Footswitch board assembly
- Front panel
- Front panel components, including the Footswitch receptacle, knobs, power switch, and REM lever assembly
- Fuses, including two in the fuse drawer, one on the low voltage power supply, and one on the Power Supply/RF board
- Handle
- Heat sink (left front, left rear, and right heat sinks) components
- Low voltage power supply
- Power entry module
- Power Supply/RF board

For your reference, this section also includes an electrical cable interconnect diagram that illustrates all cable connections.

For illustrations of parts described in this section, refer to the schematics in the separate *Schematics Supplement*.

Interconnect Diagram

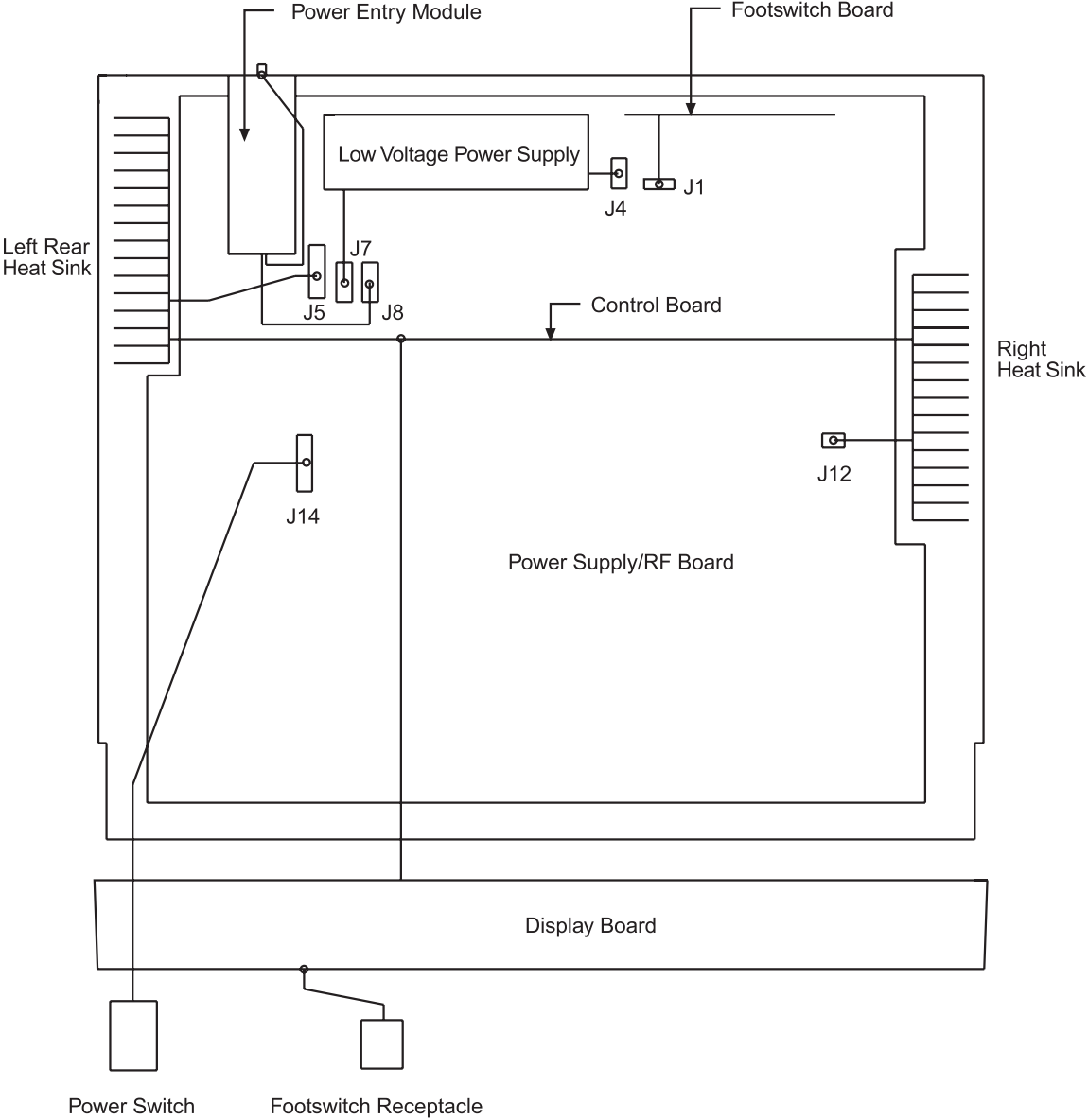

Figure 8-1.
Electric cable connections

Battery

Equipment

- Phillips screwdriver

Warning

Electric Shock Hazard – To allow stored energy to dissipate after disconnecting power, wait at least five minutes before replacing parts.

Caution

The generator contains electrostatic-sensitive components. When repairing the generator, work at a static-control workstation. Wear a grounding strap when handling electrostatic-sensitive components, **except** when working on an energized generator. Handle circuit boards by their nonconductive edges. Use an antistatic container for transport of electrostatic-sensitive components and circuit boards.

Notice

Calibrate the generator after you install a new battery. Battery backed RAM loses calibration values when you replace the battery. Refer to *Calibrating the Force EZ-C Series Electrosurgical Generator* in Section 6 for instructions.

Procedure

1. Turn off the generator and disconnect the power cord from the wall receptacle.
2. Loosen the four screws that secure the cover to the chassis. Lift the cover off the chassis.
3. Looking from the rear of the generator, locate the battery at the upper left corner of the Control board.
4. Grasp the battery and snap it out of the socket.
5. Install a new button-cell 3V battery. Refer to *Control Board Components* in Section 10 for the Valleylab replacement battery or call the Valleylab Service Center for information about approved battery replacements.
 - a. Position the battery so that the positive side of the battery faces out (visible).
 - b. Snap the battery into the socket so it is firmly seated.
6. Position the cover above the chassis and slide it down. Tighten the four screws that secure the cover to the chassis.

► Important

Internal memory loses all stored data (refer to Section 4, Internal Memory) when you remove the battery .

Control Board

Equipment

- Phillips screwdriver

Warning

Electric Shock Hazard – To allow stored energy to dissipate after disconnecting power, wait at least five minutes before replacing parts.

Caution

The generator contains electrostatic-sensitive components. When repairing the generator, work at a static-control workstation. Wear a grounding strap when handling electrostatic-sensitive components, **except** when working on an energized generator. Handle circuit boards by their nonconductive edges. Use an antistatic container for transport of electrostatic-sensitive components and circuit boards.

Notice

Calibrate the generator after you install a new battery. Battery backed RAM loses calibration values when you replace the battery. Refer to *Calibrating the Force EZ-C Series Electrosurgical Generator* in Section 6 for instructions.

Procedure

1. Turn off the generator and disconnect the power cord from the wall receptacle.
2. Loosen the four screws that secure the cover to the chassis. Lift the cover off the chassis.
3. Remove the screw that secures the retention bracket to the left rear heat sink. Set the screw and bracket aside for reinstallation.
4. Unlock the connector on the Control board and disconnect the Display board ribbon cable from the Control board.
5. Carefully slide the Control board straight up to disconnect it from the Power Supply/RF board.
6. Verify that the product packaging contains the correct part number for the Force EZ-C Series Electrosurgical Generator Control board. Do not install any other Control board.
7. Position the new Control board over the Power Supply/RF board, fitting the edge of the board into the slot on the right heat sink. Slide the board down, carefully fitting the edge connector into the matching connector on the Power Supply/RF board.
8. Place the retention bracket on the left rear heat sink and install the screw that secures the bracket to the heat sink.
9. Connect the Display board ribbon cable to the Control board and lock the connector.

10. Position the cover above the chassis and slide it down. Tighten the four screws that secure the cover to the chassis.

Display Board

Equipment

- Phillips screwdriver
- Pliers

Warning

Electric Shock Hazard – To allow stored energy to dissipate after disconnecting power, wait at least five minutes before replacing parts.

Caution

The generator contains electrostatic-sensitive components. When repairing the generator, work at a static-control workstation. Wear a grounding strap when handling electrostatic-sensitive components, **except** when working on an energized generator. Handle circuit boards by their nonconductive edges. Use an antistatic container for transport of electrostatic-sensitive components and circuit boards.

Notice

Calibrate the generator after you install a new battery. Battery backed RAM loses calibration values when you replace the battery. Refer to *Calibrating the Force EZ-C Series Electrosurgical Generator* in Section 6 for instructions.

Remove the Display Board

1. Turn off the generator and disconnect the power cord from the wall receptacle.
2. Loosen the four screws that secure the cover to the chassis. Lift the cover off the chassis.
3. Remove the front panel assembly.
 - a. Unlock the connector on the Control board and disconnect the Display board ribbon cable from the Control board.
 - b. Disconnect the power switch cable from the Power Supply/RF board.
 - c. Remove the four screws that secure the front panel to the chassis. Save the screws for reinstallation.
 - d. Slide the front panel assembly forward, carefully disengaging it from the electrical contacts on the Power Supply/RF board.

► **Important**

Replace the knob shaft clips with new ones.

4. Using pliers, pry the clips off each knob shaft and pull the knobs out. Save the knobs for reinstallation. Discard the clips.
5. Remove the Display board from the front panel.
 - a. Remove the eight screws that secure the Display board to the front panel. Save the screws and ground clips for reinstallation.
 - b. Partially separate the Display board from the front panel and disconnect the footswitch cable from the Display board.
6. Note the orientation of the REM lever and spring on the Display board. Then, slide the spring off the lever and remove the lever. Set the spring and lever aside for reinstallation.

Install the Display Board

1. Install the REM lever and spring.
 - a. Install the lever on the new Display board.
 - b. Slide the spring onto the lever, positioning it between the lever and the board.
2. Attach the Display board to the front panel.
 - a. Position the Display board inside the front panel and connect the Footswitch receptacle cable to the connector on the Display board.
 - b. Place the Display board over the standoffs, ensuring that the REM lever is correctly positioned in the grooves on the front panel.
 - c. Carefully install the eight screws and ground clips that secure the board to the front panel (avoid cutting new threads).
3. Slip the knob shafts into the openings on the front panel and push a new clip onto each shaft.
4. Install the front panel assembly.
 - a. Position the front panel assembly in front of the chassis and carefully slide it into the electrical contacts on the Power Supply/RF board.
 - b. Install the four screws that secure the front panel to the chassis.
 - c. Connect the power switch cable to J14 on the Power Supply/RF board.
 - d. Connect the Display board ribbon cable to the Control board and lock the connector.
5. Position the cover above the chassis and slide it down. Tighten the four screws that secure the cover to the chassis.

Display Board Seven-Segment LED

► Important

Do not remove the REM lever and spring from the Display board. Removal of the REM lever and spring is necessary only when you replace the Display board (or the REM lever and spring).

1. Remove the Display board (observe all warnings and cautions). Refer to *Display Board* earlier in this section.
2. Grasp the seven-segment LED and pull it out of the Display board, taking care not to bend the pins. Note the orientation of pin 1 (the corner with the small 45° chamfer).
3. Verify that the replacement LED is the correct color, size, etc. Refer to the parts list in Section 10.
4. Install the new seven-segment LED, making sure that the orientation of pin 1 (designated by the small 45° chamfer) is the same as that of the LED you removed.
5. Reinstall the Display board. Refer to *Display Board* earlier in this section.

Footswitch Board Assembly

Equipment

- Phillips screwdriver

Warning

Electric Shock Hazard – To allow stored energy to dissipate after disconnecting power, wait at least five minutes before replacing parts.

Caution

The generator contains electrostatic-sensitive components. When repairing the generator, work at a static-control workstation. Wear a grounding strap when handling electrostatic-sensitive components, **except** when working on an energized generator. Handle circuit boards by their nonconductive edges. Use an antistatic container for transport of electrostatic-sensitive components and circuit boards.

1. Turn off the generator and disconnect the power cord from the wall receptacle.
2. Loosen the four screws that secure the cover to the chassis. Lift the cover off the chassis.
3. Remove the Footswitch board assembly.
 - a. Disconnect the Footswitch board cable from the Power Supply/RF board.
 - b. On the rear panel, remove the four screws that secure the footswitch receptacles to the rear panel.
 - c. Unsnap the assembly from the three standoffs inside the rear panel and remove.

4. Install the new Footswitch board assembly.
 - a. Position the assembly over the three standoffs inside the rear panel and press to snap it in place.
 - b. Install the four screws that secure the footswitch receptacles to the rear panel.
 - c. Connect the Footswitch board cable to J1 on the Power Supply/RF board.
5. Position the cover above the chassis and slide it down. Tighten the four screws that secure the cover to the chassis.

Front Panel

Equipment

- Phillips screwdriver
- Pliers

Remove the Front Panel Assembly

Warning

Electric Shock Hazard – To allow stored energy to dissipate after disconnecting power, wait at least five minutes before replacing parts.

Caution

The generator contains electrostatic-sensitive components. When repairing the generator, work at a static-control workstation. Wear a grounding strap when handling electrostatic-sensitive components, **except** when working on an energized generator. Handle circuit boards by their nonconductive edges. Use an antistatic container for transport of electrostatic-sensitive components and circuit boards.

1. Turn off the generator and disconnect the power cord from the wall receptacle.
2. Loosen the four screws that secure the cover to the chassis. Lift the cover off the chassis.
3. Unlock the connector on the Control board and disconnect the Display board ribbon cable from the Control board.
4. Disconnect the power switch cable from the Power Supply/RF board.
5. Remove the four screws that secure the front panel to the chassis. Save the screws for reinstallation.
6. Slide the front panel assembly forward, carefully disengaging it from the electrical contacts on the Power Supply/RF board.

If you are replacing only the front panel housing, remove the knobs, Display board (with REM lever assembly), Footswitch receptacle, and power switch from the old assembly and install them on the new front panel housing. Follow the instructions in *Remove and Reinstall the Front Panel Components*.

or

If you are replacing the entire front panel assembly, go to *Install the Front Panel Assembly*.

Remove and Reinstall the Front Panel Components

1. Remove the knobs and Display board.
 - a. Using pliers, pry the clips off each knob shaft and pull the knobs out. Save the knobs for reinstallation. Discard the clips.
 - b. Remove the eight screws that secure the Display board to the front panel. Save the screws and ground clips for reinstallation
 - c. Partially separate the Display board from the front panel and disconnect the footswitch cable from the Display board. Do not remove the REM lever and spring from the Display board.
2. Remove the Footswitch receptacle and install it on the new front panel.
 - a. Note the location of the ground wire. Then, remove the four screws that secure the Footswitch receptacle (and ground wire) to the front panel.
 - b. Note the orientation of the Footswitch receptacle. Slide it out the front of the panel.
 - c. On the new front panel, position the receptacle over the opening, orienting the receptacle and ground wire as they were in the old front panel. Press to fit the receptacle into the opening.
 - d. Install the screw that secures the ground wire (and Footswitch receptacle) to the front panel. Install the remaining three screws that secure the Footswitch receptacle to the front panel.
3. Remove the power switch and install it on the new front panel.
 - a. Inside the front panel, use the pliers to press the four tabs that secure the power switch and push the switch (and connected cable) out of the opening.
 - b. From outside the new front panel, route the power switch cable through the power switch opening.
 - c. Position the power switch with the on (|) switch above the off (O) switch. Press to snap the switch into place.

4. Install the Display board and knobs on the new front panel.
 - a. Position the Display board inside the front panel and connect the Footswitch receptacle cable to the connector on the Display board.
 - b. Place the Display board over the standoffs, ensuring that the REM lever is correctly positioned in the grooves. Carefully install the eight screws and ground clips that secure the board to the front panel (avoid cutting new threads).
 - c. Slip the knob shafts into the openings on the new front panel and push a new clip onto each shaft.

Install the Front Panel Assembly

1. Position the front panel assembly in front of the chassis and carefully slide it into the electrical contacts on the Power Supply/RF board.
2. Install the four screws that secure the front panel to the chassis.
3. Connect the power switch cable to J14 on the Power Supply/RF board.
4. Connect the Display board ribbon cable to the Control board and lock the connector.
5. Position the cover above the chassis and slide it down. Tighten the four screws that secure the cover to the chassis.

Front Panel Footswitch Receptacle

Important

Do not remove the REM lever and spring from the Display board. Removal of the REM lever and spring is necessary only when you replace the Display board (or the REM lever and spring).

1. Remove the Display board (observe all warnings and cautions). Refer to *Display Board* earlier in this section.
2. Note the location of the ground wire. Then, remove the four screws that secure the Footswitch receptacle (and ground wire) to the front panel. Save the screws for reinstallation.
3. Note the orientation of the Footswitch receptacle. Slide it out the front of the panel.
4. Position the new Footswitch receptacle over the opening, orienting the receptacle and ground wire as you noted earlier. Press to fit the receptacle into the opening.
5. Install the screw that secures the ground wire (and Footswitch receptacle) to the front panel. Install the remaining three screws that secure the Footswitch receptacle to the front panel.
6. Reinstall the Display board. Refer to *Display Board* earlier in this section.

Front Panel Knob

Equipment

- Phillips screwdriver
- Pliers

Warning

Electric Shock Hazard – To allow stored energy to dissipate after disconnecting power, wait at least five minutes before replacing parts.

Caution

The generator contains electrostatic-sensitive components. When repairing the generator, work at a static-control workstation. Wear a grounding strap when handling electrostatic-sensitive components, **except** when working on an energized generator. Handle circuit boards by their nonconductive edges. Use an antistatic container for transport of electrostatic-sensitive components and circuit boards.

Procedure

1. Turn off the generator and disconnect the power cord from the wall receptacle.
2. Remove the front panel assembly (observe all warnings and cautions). Refer to *Front Panel* earlier in this section.
3. Using pliers, pry the clip off each knob shaft. Then, pull the knobs out. Discard the clips.
4. For each knob, insert the knob shaft into the front panel and install the new clip that secures the knob to the front panel.
5. Reinstall the front panel assembly. Refer to *Front Panel* earlier in this section.

► Important

Use new knob shaft clips.

Front Panel Power Switch

1. Remove the front panel assembly (observe all warnings and cautions). Refer to *Front Panel* earlier in this section.
2. Inside the front panel, use the pliers to press the four tabs that secure the power switch and push the switch (and connected cable) out the opening.

Figure 8-2.
Power switch and cable connections

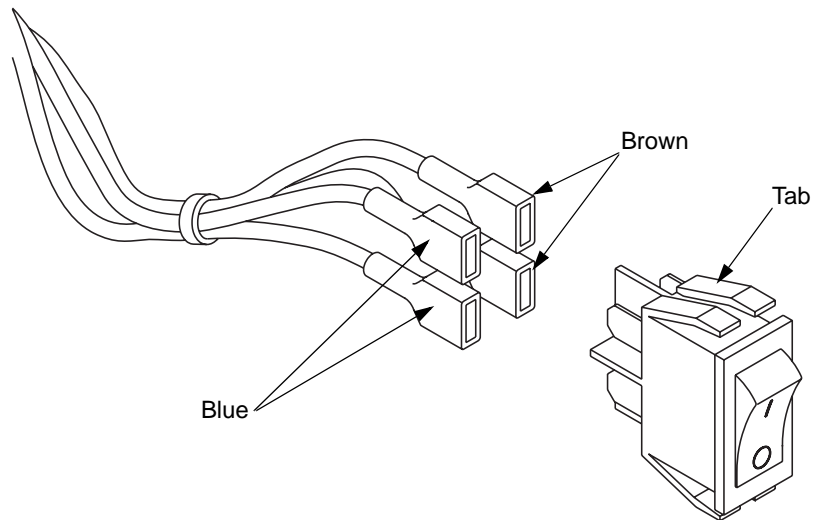

1. Check and correct the cable connections on the new power switch assembly, using the illustration and the assembly you just removed as a reference.
2. Outside the front panel, route the power switch cable through the power switch opening.
3. Position the power switch with the on (|) switch above the off (O) switch. Press to snap the switch into place.
4. Reinstall the front panel assembly. Refer to *Front Panel* earlier in this section.

Front Panel REM Lever

1. Remove the front panel assembly (observe all warnings and cautions). Refer to *Front Panel* earlier in this section.
2. Remove the Display board.
 - a. Remove the eight screws that secure the board to the front panel. Set the screws and ground clips aside for reinstallation.
 - b. Partially separate the Display board from the front panel and disconnect the footswitch cable from the Display board.
3. Note the orientation of the REM lever and spring assembly. Then, slide the spring off the lever and remove the lever from the Display board.
4. Install the new REM lever and spring.
 - a. Install the lever on the Display board.
 - b. Slide the new spring onto the lever, positioning it between the lever and the board.
5. Install the Display board.
 - a. Position the Display board inside the front panel and connect the footswitch receptacle cable to the connector on the Display board.
 - b. Place the Display board over the standoffs, ensuring that the REM lever is correctly positioned in the grooves on the front panel.
 - c. Carefully install the eight screws and ground clips that secure the board to the front panel (avoid cutting new threads).
6. Reinstall the front panel assembly. Refer to *Front Panel* earlier in this section.

Fuses

This section contains instructions for replacing fuses in the fuse drawer, on the low voltage power supply, and on the Power Supply/RF board.

Replacing Fuses in the Fuse Drawer

Equipment

- Small screwdriver

Warning

Fire Hazard – For continued protection against fire hazard, replace fuses only with fuses of the same type and rating as the original fuse.

Procedure

1. Turn off the generator. Disconnect the power cord from the wall receptacle. Disconnect the power cord from the rear panel.

2. Release the fuse drawer by inserting the screwdriver into the slot on top of the fuse drawer and pulling gently on the drawer. Slide the drawer out.
3. Remove each blown fuse from the fuse drawer.
4. Replace each blown fuse with one of the same type and rating.
 - For 110-120 V operation, use two F8A fuses.
 - For 220-240 V operation, use two T4A fuses.
5. Slide the fuse drawer into its slot until it snaps into place.
6. Connect the power cord to the receptacle on the rear panel.

Replacing the Fuse on the Low Voltage Power Supply

Equipment

- Phillips screwdriver
- Fuse puller

Remove the blown fuse from the low voltage power supply.

Warning

Electric Shock Hazard – To allow stored energy to dissipate after disconnecting power, wait at least five minutes before replacing parts.

Caution

The generator contains electrostatic-sensitive components. When repairing the generator, work at a static-control workstation. Wear a grounding strap when handling electrostatic-sensitive components, **except** when working on an energized generator. Handle circuit boards by their nonconductive edges. Use an antistatic container for transport of electrostatic-sensitive components and circuit boards.

1. Turn off the generator and disconnect the power cord from the wall receptacle.
2. Loosen the four screws that secure the cover to the chassis. Lift the cover off the chassis.
3. Remove the Control board.
 - a. Remove the screw that secures the retention bracket to the left rear heat sink. Set the screw and bracket aside for reinstallation.
 - b. Unlock the connector on the Control board and disconnect the Display board ribbon cable from the Control board.
 - c. Carefully slide the Control board straight up to disconnect it from the Power Supply/RF board. Set the board aside in an antistatic container for reinstallation.
4. Use a fuse puller to remove the blown fuse from the low voltage power supply.

Install a new fuse on the low voltage power supply.**Warning**

Fire Hazard – For continued protection against fire hazard, replace fuses only with fuses of the same type and rating as the original fuse.

1. Replace the blown fuse with a fuse of the same type and rating (F2A).
2. Install the Control board.
 - a. Position the Control board over the Power Supply/RF board, fitting the edge of the Control board into the slot on the right heat sink.
 - b. Slide the board down, carefully fitting the edge connector into the matching connector on the Power Supply/RF board.
 - c. Place the retention bracket on the left rear heat sink and install the screw that secures the bracket to the heat sink.
 - d. Connect the Display board ribbon cable to the Control board and lock the connector.
3. Position the cover above the chassis and slide it down. Tighten the four screws that secure the cover to the chassis.

Replacing the Fuse on the Power Supply/RF Board**Equipment**

- Phillips screwdriver
- Fuse puller

Warning

Electric Shock Hazard.– To allow stored energy to dissipate after disconnecting power, wait at least five minutes before replacing parts.

Fire Hazard.– For continued protection against fire hazard, replace fuses only with fuses of the same type and rating as the original fuse.

Caution

The generator contains electrostatic-sensitive components. When repairing the generator, work at a static-control workstation. Wear a grounding strap when handling electrostatic-sensitive components, **except** when working on an energized generator. Handle circuit boards by their nonconductive edges. Use an antistatic container for transport of electrostatic-sensitive components and circuit boards.

Procedure

1. Turn off the generator and disconnect the power cord from the wall receptacle.
2. Loosen the four screws that secure the cover to the chassis. Lift the cover off the chassis.
3. Locate the fuse at the rear/center of the Power Supply/RF board. Use a fuse puller to remove the blown fuse.
4. Replace the blown fuse with one of the same type and rating (F6.3A).
5. Position the cover above the chassis and slide it down. Tighten the four screws that secure the cover to the chassis.

Handle

1. Remove the Power Supply/RF board and attached heat sinks (observe all warnings and cautions). Refer to *Power Supply/RF board* later in this section.
2. Remove the handle.
 - a. Tilt the generator onto its side to access the underside of the chassis.
 - b. Remove the four screws that secure the handle to the floor of the chassis.
 - c. Note the orientation of the handle, then remove the handle.
3. Install a new handle.
 - a. Position the new handle inside the chassis. Hold it in place and install the four screws on the underside of the chassis that secure the handle to the chassis.
 - b. Return the generator to an upright position.
4. Reinstall the Power Supply/RF board and attached heat sinks. Refer to *Power Supply/RF board* later in this section.

Left Front Heat Sink Component

Equipment

- Phillips screwdriver

Remove the Left Front Heat Sink

Warning

Electric Shock Hazard.— To allow stored energy to dissipate after disconnecting power, wait at least five minutes before replacing parts.

Caution

The generator contains electrostatic-sensitive components. When repairing the generator, work at a static-control workstation. Wear a grounding strap when handling electrostatic-sensitive components, **except** when working on an energized generator. Handle circuit boards by their nonconductive edges. Use an antistatic container for transport of electrostatic-sensitive components and circuit boards.

1. Turn off the generator and disconnect the power cord from the wall receptacle.
2. Loosen the four screws that secure the cover to the chassis. Lift the cover off the chassis.
3. Remove the two screws that secure the left front heat sink to the Power Supply/RF board. Save the screws for reinstallation.
4. Carefully lift the left front heat sink to disconnect the heat sink components from their sockets on the board.

Replace the Left Front Heat Sink Components.

Figure 8-3.
Left front heat sink components

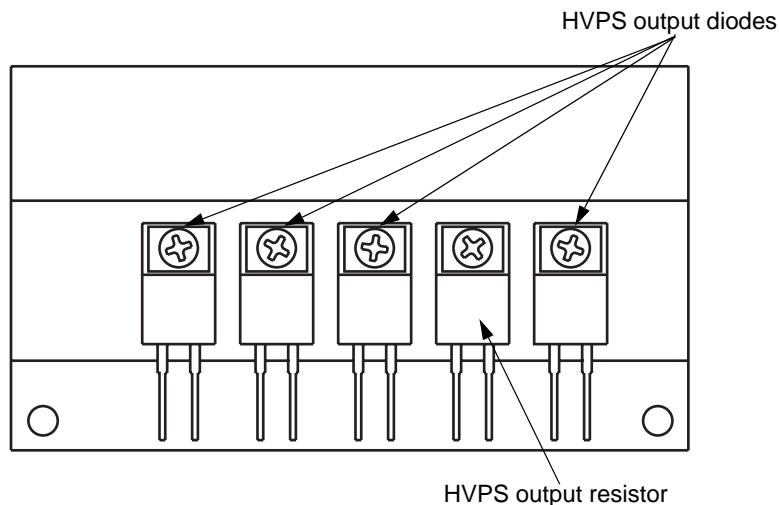

- To replace the **HVPS (high voltage power supply) output resistor**, remove the screw and washer that secure it to the heat sink. Position the new HVPS output resistor on the heat sink and reinstall the washer and screw.
- To replace one or more **HVPS (high voltage power supply) output diodes**, remove the screw and washer that secure the diode to the heat sink. Position the new diode on the heat sink and reinstall the washer and screw.

Install the Left Front Heat Sink

Notice

Calibrate the generator after you install a new heatsink or replace components on the heat sink. Component differences may affect output waveforms. Refer to *Calibrating the Force EZ-C Series Electrosurgical Generator* in Section 6 for instructions.

1. Slide the left front heat sink component leads into the matching sockets on the Power Supply/RF board.
2. Install the two screws that secure the heat sink to the Power Supply/RF board.
3. Position the cover above the chassis and slide it down. Tighten the four screws that secure the cover to the chassis.

Left Rear Heat Sink Component

Equipment

- Phillips screwdriver

Remove the Left Rear Heat Sink

Warning

Electric Shock Hazard.— To allow stored energy to dissipate after disconnecting power, wait at least five minutes before replacing parts.

Caution

The generator contains electrostatic-sensitive components. When repairing the generator, work at a static-control workstation. Wear a grounding strap when handling electrostatic-sensitive components, **except** when working on an energized generator. Handle circuit boards by their nonconductive edges. Use an antistatic container for transport of electrostatic-sensitive components and circuit boards.

1. Turn off the generator and disconnect the power cord from the wall receptacle.
2. Loosen the four screws that secure the cover to the chassis. Lift the cover off the chassis.
3. Remove the screw that secures the retention bracket to the left rear heat sink. Set the screw and bracket aside for reinstallation.
4. Disconnect the 4-wire heat sink (bridge rectifier) cable from J5 on the Power Supply/RF board.
5. Remove the two screws that secure the heat sink to the chassis. Next, insert the screwdriver into the holes on the outside of the chassis and remove the two screws that secure the heat sink to the Power Supply/RF board. Set the screws aside for reinstallation.
6. Carefully lift the left rear heat sink to disconnect the heat sink components from their sockets on the Power Supply/RF board.

Replace the Left Rear Heat Sink Components

Figure 8-4.
Left rear heat sink components

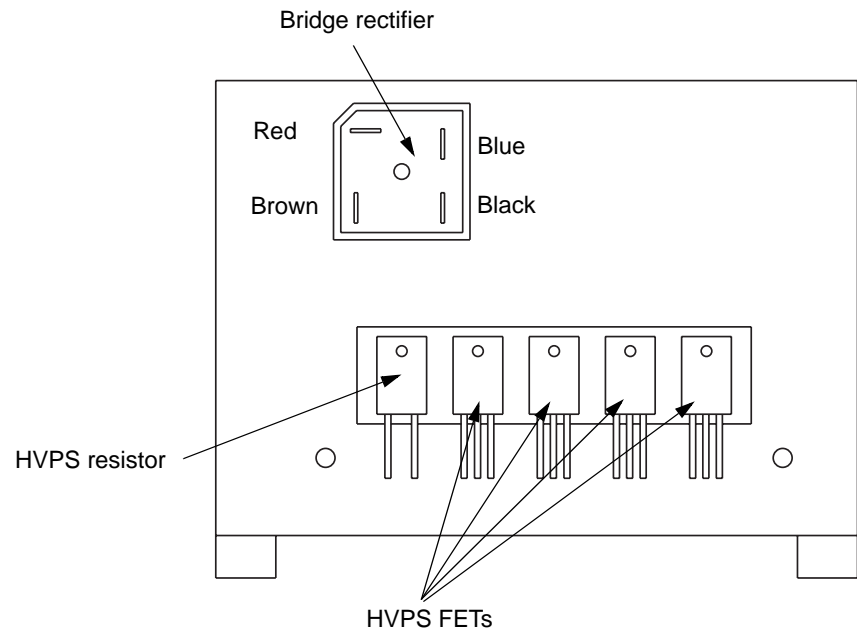

- To replace the HVPS (high voltage power supply) resistor, remove the screw and washer that secure it to the heat sink. Position the new HVPS resistor on the heat sink and reinstall the washer and screw.
- To replace one or more of the four HVPS FETs, remove the screw and washer that secure the FET to the heat sink. Position the new FET on the heat sink and reinstall the washer and screw.
- To replace the bridge rectifier, note the orientation of the four wires. Then, detach them from the bridge rectifier.

Remove the screw that secures the bridge rectifier to the heat sink. Position the new bridge rectifier on the heat sink and reinstall the screw.

Connect the four wires to the appropriate locations on the bridge rectifier.

Install the Left Rear Heat Sink

Notice

Calibrate the generator after you install a new heatsink or replace components on the heat sink. Component differences may affect output waveforms. Refer to *Calibrating the Force EZ-C Series Electrosurgical Generator* in Section 6 for instructions.

1. Position the heat sink above the left rear of the chassis and slide the heat sink component leads into the matching sockets on the Power Supply/RF board.
2. Through the holes on the outside of the chassis, install the two screws that secure the heat sink to the Power Supply/RF board.
3. Install the two screws that secure the heat sink to the chassis.
4. Connect the 4-wire bridge rectifier cable to J5 on the Power Supply/RF board.
5. Place the retention bracket on the left rear heat sink and install the screw that secures the bracket to the heat sink.
6. Position the cover above the chassis and slide it down. Tighten the four screws that secure the cover to the chassis.

Right Heat Sink Component

Equipment

- Phillips screwdriver

Remove the Right Heat Sink

Warning

Electric Shock Hazard.— To allow stored energy to dissipate after disconnecting power, wait at least five minutes before replacing parts.

Caution

The generator contains electrostatic-sensitive components. When repairing the generator, work at a static-control workstation. Wear a grounding strap when handling electrostatic-sensitive components, **except** when working on an energized generator. Handle circuit boards by their nonconductive edges. Use an antistatic container for transport of electrostatic-sensitive components and circuit boards.

1. Turn off the generator and disconnect the power cord from the wall receptacle.
2. Loosen the four screws that secure the cover to the chassis. Lift the cover off the chassis.

3. Remove the Control board.
 - a. Remove the screw that secures the retention bracket to the left rear heat sink. Set the screw and bracket aside for reinstallation.
 - b. Unlock the connector on the Control board and disconnect the Display board ribbon cable from the Control board.
 - c. Carefully slide the Control board straight up to disconnect it from the Power Supply/RF board. Set the board aside in an antistatic container for reinstallation.
4. Disconnect the right heat sink resistor cable from J12 on the Power Supply/RF board.
5. Remove the two screws that secure the heat sink to the chassis. Next, insert the screwdriver into the holes on the outside of the chassis and remove the two screws that secure the heat sink to the Power Supply/RF board. Set the screws aside for reinstallation.
6. Carefully lift the right heat sink to disconnect the heat sink components from their sockets on the Power Supply/RF board.

Replace the Right Heat Sink Components

Figure 8-5.
Right heat sink components

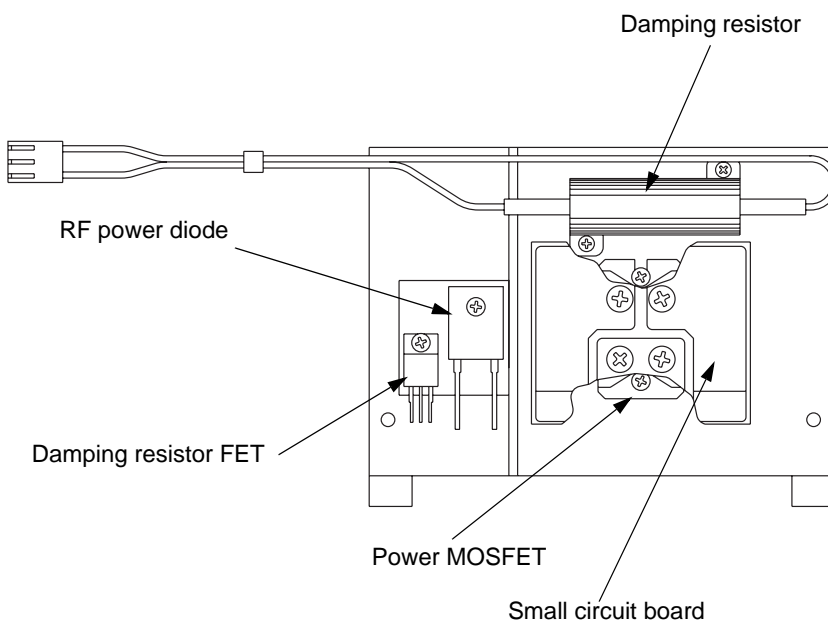

- To replace the damping resistor FET, remove the screw and washer that secure the FET to the heat sink. Position the new damping resistor FET on the heat sink and reinstall the washer and screw.
- To replace the RF power diode, remove the screw that secures the diode to the heat sink. Position the new RF power diode on the heat sink and reinstall the screw.

- To replace the damping resistor, remove the two screws that secure the top and bottom of the resistor to the heat sink. Position the new damping resistor on the heat sink and reinstall the screws.
- To replace the power MOSFET (under the small circuit board), remove the four screws that secure the small circuit board to the heat sink. Set the board and screws aside for reinstallation.

Note the orientation of the notch on the power MOSFET. Then, remove the 2 screws that secure the power MOSFET. Position the new power MOSFET on the heat sink and reinstall the two screws.

Position the small circuit board over the power MOSFET and reinstall the four screws that secure the board to the heat sink.

Install the Right Heat Sink

Notice

Calibrate the generator after you install a new heatsink or replace components on the heat sink. Component differences may affect output waveforms. Refer to *Calibrating the Force EZ-C Series Electrosurgical Generator* in Section 6 for instructions.

1. Position the right heat sink above the right side of the chassis and slide the heat sink component leads into the matching sockets on the Power Supply/RF board.
2. Through the holes on the outside of the chassis, install the two screws that secure the heat sink to the Power Supply/RF board.
3. Install the two screws that secure the heat sink to the chassis.
4. Connect the right heat sink resistor cable to J12 on the Power Supply/RF board.
5. Install the Control board.
 - a. Position the Control board over the Power Supply/RF board, fitting the edge of the board into the slot on the right heat sink. Slide the board down, carefully fitting the edge connector into the matching connector on the Power Supply/RF board.
 - b. Place the retention bracket on the left rear heat sink and install the screw that secures the bracket to the heat sink.
 - c. Connect the Display board ribbon cable to the Control board and lock the connector.
6. Position the cover above the chassis and slide it down. Tighten the four screws that secure the cover to the chassis.

Low Voltage Power Supply

Equipment

- Phillips screwdriver

Remove the Low Voltage Power Supply

Warning

Electric Shock Hazard.— To allow stored energy to dissipate after disconnecting power, wait at least five minutes before replacing parts.

Caution

The generator contains electrostatic-sensitive components. When repairing the generator, work at a static-control workstation. Wear a grounding strap when handling electrostatic-sensitive components, **except** when working on an energized generator. Handle circuit boards by their nonconductive edges. Use an antistatic container for transport of electrostatic-sensitive components and circuit boards.

1. Turn off the generator and disconnect the power cord from the wall receptacle.
2. Loosen the four screws that secure the cover to the chassis. Lift the cover off the chassis.
3. Remove the Control board.
 - a. Remove the screw that secures the retention bracket to the left rear heat sink. Set the screw and bracket aside for reinstallation.
 - b. Unlock the connector on the Control board and disconnect the Display board ribbon cable from the Control board.
 - c. Carefully slide the Control board straight up to disconnect it from the Power Supply/RF board. Set the board aside in an antistatic container for reinstallation.
4. Remove the two screws that secure the low voltage power supply to the rear panel. Save them for reinstallation.
5. Snap the low voltage power supply off the two standoffs and lift it off the rear panel.
6. Disconnect the Power Supply/RF board cables (spade lug and two other connectors) from the low voltage power supply.

Install the Low Voltage Power Supply

Figure 8-6.
Connections to the low voltage
power supply

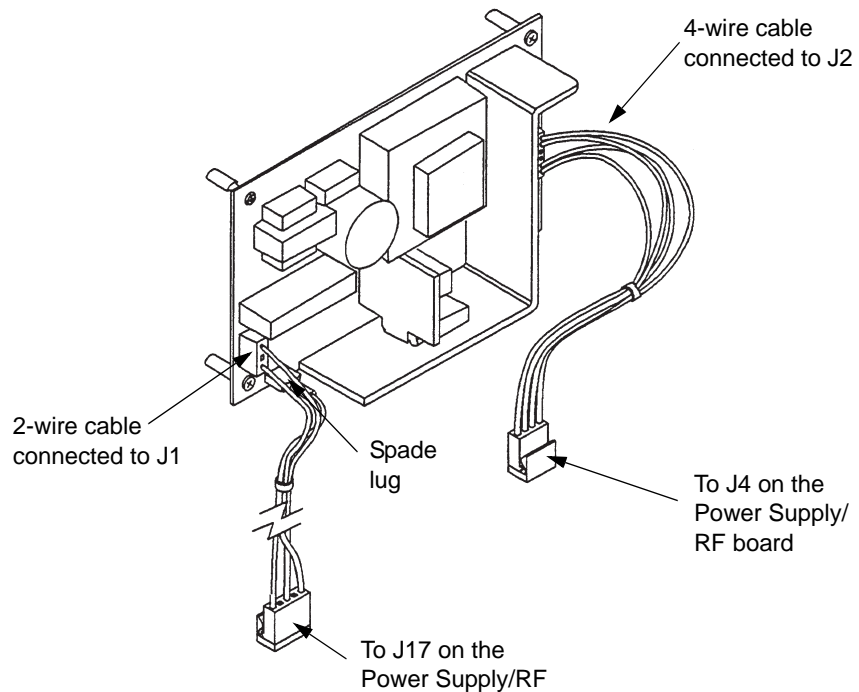

1. Connect the 2-wire connector (from J7 on the Power Supply/RF board) to the lower left of the low voltage power supply.
2. Connect the spade lug to the ground connection on the lower left of the low voltage power supply.
3. Connect the 4-wire cable (from J4 on the Power Supply/RF board) to the connector on the right of the low voltage power supply.
4. Position the new low voltage power supply over the two standoffs on the rear panel and press to snap it in place.
5. Install the two screws that secure it to the rear panel.
6. Install the Control board.
 - a. Fit the edge of the Control board into the slot on the right heat sink. Slide the board down, carefully fitting the edge connector into the matching connector on the Power Supply/RF board.
 - b. Place the retention bracket on the left rear heat sink and install the screw that secures the bracket to the heat sink.
 - c. Connect the Display board ribbon cable to the Control board and lock the connector.
7. Position the cover above the chassis and slide it down. Tighten the four screws that secure the cover to the chassis.

Power Entry Module

Equipment

- Phillips screwdriver

Remove the Power Entry Module

Warning

Electric Shock Hazard.— To allow stored energy to dissipate after disconnecting power, wait at least five minutes before replacing parts.

Caution

The generator contains electrostatic-sensitive components. When repairing the generator, work at a static-control workstation. Wear a grounding strap when handling electrostatic-sensitive components, **except** when working on an energized generator. Handle circuit boards by their nonconductive edges. Use an antistatic container for transport of electrostatic-sensitive components and circuit boards.

1. Turn off the generator and disconnect the power cord from the wall receptacle.
2. Disconnect the power cord from the power entry module.
3. Loosen the four screws that secure the cover to the chassis. Lift the cover off the chassis.
4. Remove the Control board.
 - a. Remove the screw that secures the retention bracket to the left rear heat sink. Set the screw and bracket aside for reinstallation.
 - b. Unlock the connector on the Control board and disconnect the Display board ribbon cable from the Control board.
 - c. Carefully slide the Control board straight up to disconnect it from the Power Supply/RF board. Set the board aside in an antistatic container for reinstallation.
5. Disconnect the power entry module cable from the Power Supply/RF board.
6. Remove the two screws that secure the power entry module to the rear panel. Save the screws for reinstallation.
7. Slide the module out the rear panel until you can access the grounding lug post inside the rear panel. Then, remove the mounting screw that secures the ground wire ring terminal to the grounding lug. Save the screw for reinstallation.
8. Remove the power entry module assembly from the unit.

Install the Power Entry Module

1. Connect the cables on the new power entry module, using the module you just removed as a reference.

Figure 8-7.
Cable connections to the power entry module

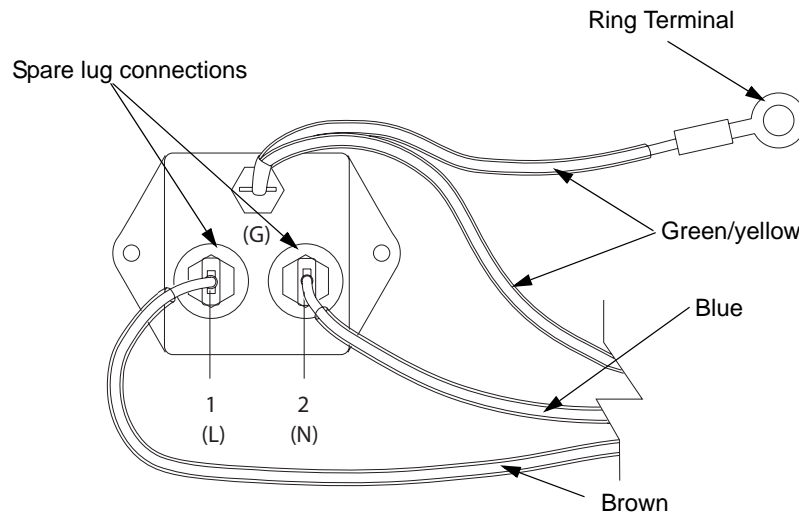

1. Position the new power entry module near the rear panel opening, routing the cable/ring terminal through the opening.
2. Install the screw that secures the ring terminal to the grounding lug.
3. Slide the power entry module into place. Install the two screws that secure it to the rear panel.
4. Connect the power entry module cable to J8 on the Power Supply/RF board.
5. Install the Control board.
 - a. Position the Control board over the Power Supply/RF board, fitting the edge of the board into the slot on the right heat sink. Slide the board down, carefully fitting the edge connector into the matching connector on the Power Supply/RF board.
 - b. Place the retention bracket on the left rear heat sink and install the screw that secures the bracket to the heat sink.
 - c. Connect the Display board ribbon cable to the Control board and lock the connector.
6. Position the cover above the chassis and slide it down. Tighten the four screws that secure the cover to the chassis.
7. Check the fuses in the fuse drawer and install new fuses, if necessary. Refer to *Fuses* in this section.
8. Connect the power cord to the receptacle on the rear panel.

Power Supply/RF Board

Equipment

- Phillips screwdriver

Remove the Power Supply/RF Board and Heat Sinks

Warning

Electric Shock Hazard.— To allow stored energy to dissipate after disconnecting power, wait at least five minutes before replacing parts.

Caution

The generator contains electrostatic-sensitive components. When repairing the generator, work at a static-control workstation. Wear a grounding strap when handling electrostatic-sensitive components, **except** when working on an energized generator. Handle circuit boards by their nonconductive edges. Use an antistatic container for transport of electrostatic-sensitive components and circuit boards.

► Important

Save all components, brackets, screws, etc. for reinstallation.

1. Turn off the generator and disconnect the power cord from the wall receptacle.
2. Loosen the four screws that secure the cover to the chassis. Lift the cover off the chassis.
3. Remove the front panel assembly.
 - a. Unlock the connector on the Control board and disconnect the Display board ribbon cable from the Control board.
 - b. Disconnect the power switch cable from the Power Supply/RF board.
 - c. Remove the 4 screws that secure the front panel to the chassis.
 - d. Slide the front panel assembly forward, carefully disengaging it from the electrical contacts on the Power Supply/RF board.
4. Remove the Control board.
 - a. Remove the screw that secures the retention bracket to the left rear heat sink.
 - b. Carefully slide the Control board straight up to disconnect it from the Power Supply/RF board. Set the board aside in an antistatic container for reinstallation.

5. Disconnect the cables listed below from the Power Supply/RF board.
 - a. Footswitch board from J1.
 - b. Power entry module from J8.
 - c. Low voltage power supply (2 cables) from J4 and J7.
 - d. Serial port cable connection (if necessary) from the Serial Port connector, J9.
 - e. Any cable connection (if necessary) from the RF Activation Port connector, J11.
6. Remove the two screws that secure the left rear heat sink to the chassis.
7. Remove the two screws that secure the right heat sink to the chassis.
8. Remove the three screws that secure the Power Supply/RF board to the chassis.
9. Slide the Power Supply/RF board (and attached heat sinks) slightly forward to unlock it from the slotted standoffs and lift it out of the chassis.

Install the Power Supply/RF Board and Heat Sinks

1. Slide the Power Supply/RF board (and attached heat sinks) into the chassis until it drops into place. Slide it slightly toward the back of the chassis to lock it in place. Verify that all five standoffs are properly engaged.
2. Install the three screws that secure the board to the chassis.
3. Install the two screws that secure the right heat sink to the chassis.
4. Install the two screws that secure the left rear heat sink to the chassis.
5. Connect the cables listed below to the Power Supply/RF board.
 - a. Footswitch board cable to J1.
 - b. Power entry module cable to J8.
 - c. Low voltage power supply 4-pin connector to J4.
 - d. Low voltage power supply 6-pin connector to J7.
6. Install the Control board.
 - a. Fit the edge of the Control board into the slot on the right heat sink. Slide the board down, carefully fitting the edge connector into the connector on the Power Supply/RF board.
 - b. Place the retention bracket on the left rear heat sink and install the screw that secures the bracket to the heat sink.

- 7.** Install the front panel assembly.
 - a.** Position the front panel assembly in front of the chassis and carefully slide it into the electrical contacts on the Power Supply/RF board.
 - b.** Install the four screws that secure the front panel to the chassis.
 - c.** Connect the power switch cable to J14 on the Power Supply/RF board.
 - d.** Connect the Display board ribbon cable to the Control board and lock the connector.
- 8.** Position the cover above the chassis and slide it down. Tighten the four screws that secure the cover to the chassis.

Repair Policy and Procedures

Refer to this section for the following information:

- The manufacturer's responsibility
- Returning the generator for service
- Returning circuit boards
- Service centers

Responsibility of the Manufacturer

Valleylab is responsible for the safety, reliability, and performance of the generator only under the following circumstances:

- The user has followed the installation and setup procedures in this manual.
- Persons authorized by Valleylab performed assembly operation, readjustments, modifications, or repairs.
- The electrical installation of the relevant room complies with local codes and regulatory requirements, such as the IEC and BSI.
- Equipment use is in accordance with the Valleylab instructions for use.

For warranty information, refer to the Warranty in the Preface of this manual.

Returning the Generator for Service

Before you return the generator, call your Valleylab Representative for assistance. If instructed to send the generator to Valleylab, first obtain a Return Authorization Number. Then, clean the generator and ship it to Valleylab for service.

Step 1 – Obtain a Return Authorization Number

Call the Valleylab Customer Service Center for your area to obtain a Return Authorization Number. Have the following information ready when you call:

- hospital/clinic name/customer number
- telephone number
- department/address, city, state, and zip code
- model number
- serial number
- description of the problem
- type of repair to be done

Step 2 – Clean the Generator

Warning

Electric Shock Hazard — Always turn off and unplug the generator before cleaning.

Notice

Do not clean the generator with abrasive cleaning or disinfectant compounds, solvents, or other materials that could scratch the panels or damage the generator.

- A. Turn off the generator, and unplug the power cord from the wall outlet.

- B. Thoroughly wipe all surfaces of the generator and power cord with a mild cleaning solution or disinfectant and a damp cloth. Follow the procedures approved by your institution or use a validated infection control procedure. Do not allow fluids to enter the chassis. You cannot sterilize the generator.

Step 3 – Ship the Generator

- A. Attach a tag to the generator that includes the Return Authorization Number and the information (hospital, phone number, etc.) listed in *Step 1 – Obtain a Return Authorization Number*.
- B. Be sure the generator is completely dry before you pack it for shipment. Pack it in its original shipping container, if available.
- C. Ship the generator, prepaid, to the Valleylab Service Center.

Returning Circuit Boards

Pack circuit boards for shipment as follows:

1. Place each circuit board in an electrostatic discharge (ESD) bag or container.
2. Provide a separate packing container for each circuit board.
3. Attach a tag to the container that includes the Return Authorization Number and the information (hospital, phone number, etc.) listed in *Step 1-Obtain a Return Authorization Number*.
4. Ship the circuit board prepaid to the Valleylab Service Center.

Service Centers

For a complete list of service centers worldwide, please refer to the Valleylab website:

<http://www.valleylab.com/valleylab/international/service-world.html>

Service Parts

In this section:

- Ordering replacement parts
- Replacement parts lists

Ordering Replacement Parts

When ordering replacement parts for this system, include this information:

- Model number (located on the rear panel of the generator)
- Serial number (located on the rear panel of the generator)
- Part number for the part you are ordering
- Modification number, if applicable

Replace all components with parts of identical construction and value. Replacement part ratings and tolerances must be equal to, or better than, original. Substituting lower grade parts can adversely affect system performance.

You can order parts from the Valleylab Service Centers listed in *Section 9, Repair Policy and Procedures*. Outside the USA, contact the Valleylab Service Center for your location. Inside the USA, contact the service center in Boulder, Colorado.

If you have any questions about ordering parts, please call Valleylab Customer Service.

Force EZ-C Series Electrosurgical Generator Assembly

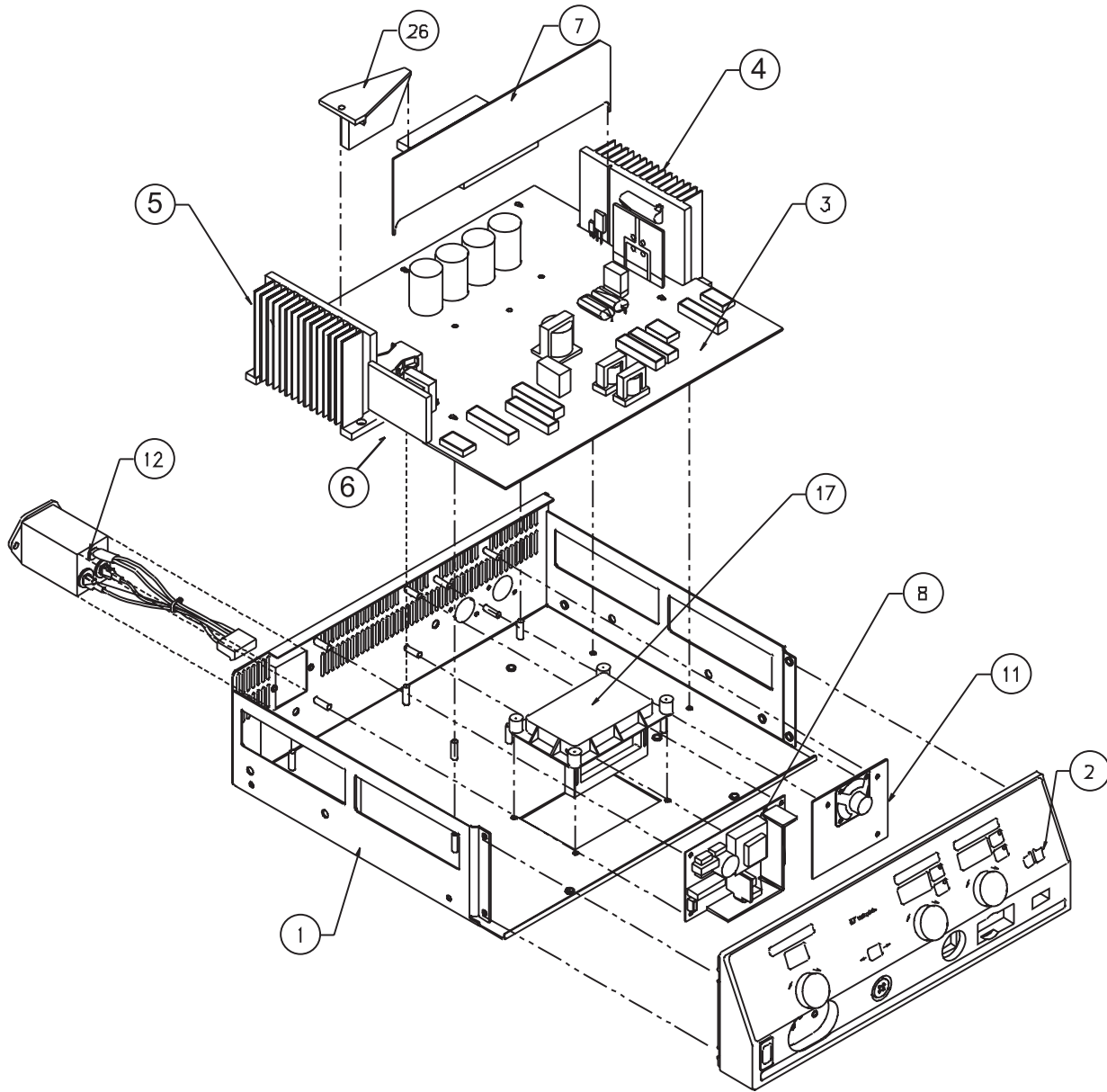

Service Parts

Figure 10-1.
Exploded view of Force EZ-C
Series Electrosurgical Generator
parts

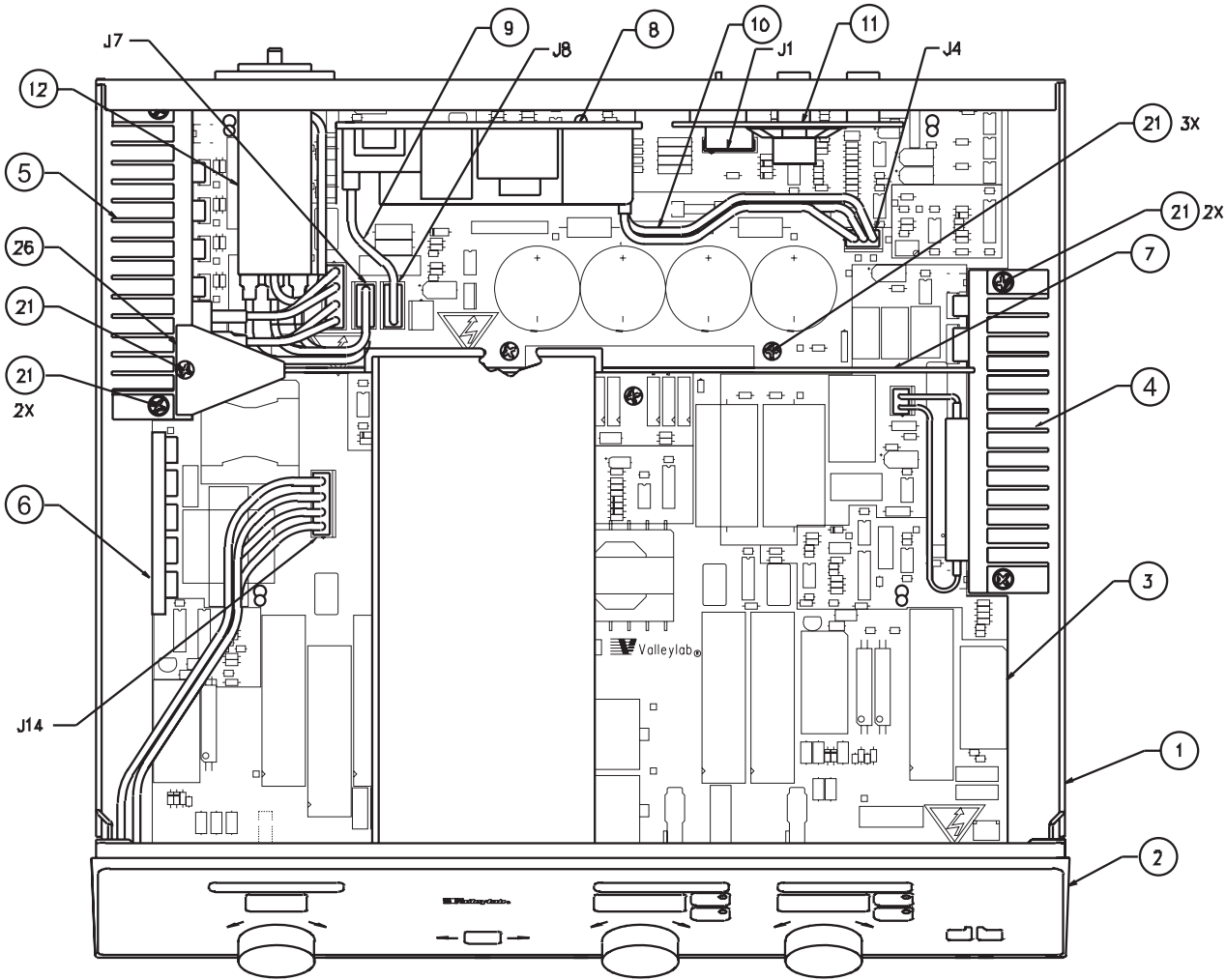

Generator Assembly Parts List

Item	Description	Part Number
1	Chassis	
	Force EZ-C	1002037
	Force EZ-8C	1002038
2	Front panel assembly <i>Includes ...</i>	202 750 092
	Display Board	1004252
	Cable, footswitch	207 500 696
	Knob assembly (knobs and clips)	202 701 959
	Power switch	243 025 037
	Cable assembly, power	207 500 552
	REM lever	223 150 033
	Spring, REM	223 500 082
	Screw, self-tapping PCB (8)	237 050 150
	Clip, knob shaft	213 130 038
	Grounding clip, left	213 130 044
	Grounding clip, right	213 130 043
	Screw, FS connection	237 050 152
3	Assembly, Power Supply/RF board This assembly includes the three heat sink assemblies. See <i>Power Supply/RF Board Components</i> in this section.	201 340 009
4	Assembly, right heat sink <i>Includes...</i>	
	Heat sink, large	207 000 212
	Transistor FET	239 200 055
	Transistor FET HI-V N-CH	239 300 044
	Diode, ultra fast, 30 A, 1000 V	239 850 038
	Cable assembly, resistor	207 500 540
	Mounting block (2)	223 100 988
	Screw, metric M3 x 10 mm lg (6)	237 050 138
	Screw, panhd M4 x 8 mm (6)	237 050 113
	Washer, shoulder	213 400 057
	PCB FET	228 349 000
	Screw, panhd M2.5 x 10 mm	237 050 159
5	Assembly, left rear heat sink <i>Includes...</i>	
	Heat sink, small	207 000 215
	Transistor FET N-CH 8 A, 500 V (4)	239 200 022
	Resistor, MF 150 Ω \pm 5%, 20 W	234 400 251
	Diode, bridge, 35 A, 400 V	239 700 058
	Cable assembly, rectifier	207 500 534
	Mounting block (2)	223 100 988
	Screw, panhd M2.5 x 10 mm (5)	237 050 159
	Screw, panhd M4 x 8 mm (2)	237 050 113
	Washer shoulder (5)	213 400 057
	Screw, panhd M4 x 12 mm	237 050 141

Item	Description	Part Number
6	Assembly, left front heat sink <i>Includes...</i>	
	Heat sink, 5.29 wide	207 000 211
	Diode, 8 A, 600 V (4)	239 850 034
	Resistor, MF 150 Ω \pm 5%, 20 W	234 400 251
	Screw, panhd M2.5 x 10 mm (5)	237 050 159
	Washer, shoulder (5)	213 400 057
7	Assembly, Control Board Refer to <i>Control Board Components</i> in this section.	201 500 023
8	Low voltage power supply	207 000 185
9	Cable assembly, low voltage power supply input	207 500 531
10	Cable assembly, power 4 wire	207 500 532
11	Assembly, Footswitch board Refer to <i>Footswitch Board Components</i> in this section.	201 342 002
12	Assembly, power entry module <i>Includes...</i>	202 701 974
	Line filter, 10A	251 400 007
	Cable assembly, power entry	207 500 533
	Ground wire assembly	207 500 535
	Fuse, T4A, 5 x 20 mm, 220 V (2)	215 100 074
	Fuse, F8A, 5 x 20 mm, 120 V (2)	215 100 070
	Tubing, heatshrink 81K 14 ID	249 001 002
17	Handle	223 300 054
21	Screw, panhd M4 x 8 mm (21)	237 050 113
26	Bracket, PCB support	223 100 993
	Serial Port Plate	223 200 615

Item	Description	Part Number
Not Shown	Power cord, right angle molded, 220 V	207 002 061
	Power cord, right angle molded, 120 V	207 002 060
	Clamp 220 V	213 150 121
	Clamp 120 V	223 301 159
	Cover	223 200 694
	Rubber foot (4)	213 400 082
	Screw, flathd M3 x 8 mm (2)	237 050 136
	Screw, panhd M4 x 6 mm (4)	237 050 137
	Screw, panhd M3 x 10 mm (6)	237 050 138
	Screw, panhd M4 x 10 mm (4)	237 050 139
	Fuse, LVPS F2A	215 100 072
	Serial number label	
	Serial tag	
	Tag, receptacle notice	
	Ground symbol label	

Control Board Components

Reference Designator	Description	Valleylab Part Number
	Programmed controller PCB	201 500 043
BT1	Battery	250 020 028
U9	IC, programmed T_ON ASIC	210 730 249

Footswitch Board Components

Reference Designator	Description	Valleylab Part Number
<i>Capacitors</i>		
C1, C2, C3, C4, C5	.01 μ F \pm 10%, 500 V	1000293
<i>Resistors</i>		
R1	Pot, 5 k	236 200 103
R2	56.2 Ω \pm 1%, 1/8 W	234 201 169
R3	1.43 k Ω \pm 1%, 1/8 W	234 201 304
<i>Miscellaneous</i>		
Item 2	Speaker, 8 Ω	241 003 001
Item 3	Screw, metric M3 x 8 mm lg (4)	237 050 149
Item 4	Nut, hex M3 x 0.5 stl zinc pld (4)	224 300 004
Item 5	Wire, Teflon 24 awg white	255 120 140
Item 8	Bracket, footswitch connector	223 301 149
J1	Monopolar footswitch connector	208 071 000
J3	Cable assembly, footswitch	207 500 207
J4	Bipolar footswitch connector	208 109 000

Power Supply/RF Board Components

Reference Designator	Description	Valleylab Part Number
<i>Capacitors</i>		
C1, C4–C7, C14, C15, C17, C19, C20, C23–C25, C29, C31–C35, C43–C47, C64, C72, C75, C81, C83C84, C87, C88, C92–C95, C97, C101, C103, C105–C107, C109, C112, C114, C116, C118, C123–C126, C129, C131, C134–C138, C141, C142, C146, C148, C153	0.1 $\mu\text{F} \pm 20\%$, 50 V	204 200 460
C2, C12, C26, C78, C79, C111, C122, C127, C130, C140, C155, C160–C164, C168, C169	1 $\mu\text{F} \pm 20\%$, 50 V	204 200 464
C3, C51, C63, C68, C90	22 $\mu\text{F} \pm 20\%$, 25 V	204 600 063
C8–C10, C22	1000 pF $\pm 10\%$, 100 V	204 200 454
C11	2200 pF $\pm 5\%$, 100 V	204 200 489
C13, C76, C77	0.47 $\mu\text{F} \pm 20\%$, 50 V	204 200 463
C16, C18, C21, C28, C37–C41, C48, C49, C53, C56, C71, C73, C74, C80, C82, C86, C113, C115, C117, C120–C121, C128, C132, C144, C145, C147, C150–C152, C156, C158, C171	.01 $\mu\text{F} \pm 10\%$, 100 V	204 200 457
C27	1500 pF $\pm 5\%$, 100 V	204 200 487
C30	180 pF $\pm 5\%$, 100 V	204 200 453
C36, C52	10 $\mu\text{F} \pm 20\%$, 25 V	204 600 067

Reference Designator	Description	Valleylab Part Number
C42	8200 pF \pm 5%, 100 V	204 200 496
C50, C98	100 pF \pm 5%, 100 V	204 200 452
C54	.01 μ F \pm 10%, 500 V	1000293
C55	0.22 μ F \pm 20%, 250 V	204 400 155
C57	33 μ F \pm 10%, 35 V	204 600 062
C58–C61	680 μ F \pm 20%, 400 V	204 500 178
C62, C69, C100	15000 pF \pm 5%, 500 V	204 300 132
C65	12000 pF \pm 5%, 500 V	204 300 130
C66, C91	680 pF \pm 5%, 500 V	204 105 022
C119	470 pF \pm 5%, 500 V	204 105 018
C67	1 μ F \pm 10%, 250 V	204 400 153
C70	2 μ F \pm 10%, 400 V	1000630
C85, C99	.047 \pm 20%, 50 V	204 200 517
C89, C108	15 μ F \pm 10%, 200 V	204 400 150
C96, C110	1000 pF \pm 5%, 100 V	204 200 485
C102, C104	33 pF \pm 5%, 100 V	204 200 451
C133, C139	6800 pF \pm 5%, 100 V	204 200 495
C143, C154, C165, C166	3900 pF \pm 5%, 500 V	204 301 044
C149, C157	0.68 μ F, \pm 5%, 100 V	204 450 016
C159	3300 pF \pm 5%, 500 V	204 300 359
C167, C170	.0047 μ F \pm 10%, 2 kV	204 200 548

Reference Designator	Description	Valleylab Part Number
<i>Diodes</i>		
CR1–CR5, CR10, CR11, CR13, CR14, CR16, CR24, CR25, CR27, CR28, CR30, CR31, CR33, CR34, CR39, CR41, D1, D2	1N4148	239 014 000
CR6	1N4007	239 500 013
CR8	Schottky 0.6 A, 40 V	239 700 066
CR9, CR12, CR15, CR26, CR32, CR37	1N5233B	239 600 000
CR18–CR21, CR29, CR35, CR38, CR40	Zener 1N5240B, 10 V	239 600 001
<i>Fuses</i>		
F1	Fuse, 5 x 20 mm, F6.3A	215 100 041
F1	Fuse holder	215 100 526
<i>Relays</i>		
K1	Socket relay	208 500 089
K1	6 pole	230 017 006
K1	Clip relay	213 130 039
K2–K8	12 V	230 013 000
K9	Relay	230 017 004
K10–K15	COTO-9442	230 017 003
<i>Transistors</i>		
Q1, Q3, Q6	FET 2N7000KL	239 200 095
Q9, Q10	FET TN2404KL	239 200 097

Reference Designator	Description	Valleylab Part Number
<i>Resistors</i>		
R1, R48, R141	1 M Ω \pm 5%, 1/4 W	234 024 135
R2, R96, R98, R129, R131, R132, R134, R144, R149	4.7 k Ω \pm 5%, 1/4 W	234 024 079
R3, R7, R10, R23–R25, R44, R45, R51–R54, R81, R84, R101, R102, R128, R135–R137, R146, R148, R155	10 k Ω \pm 5%, 1/4 W	234 024 087
R4	267 Ω \pm 1%, 1/8 W	234 201 234
R5	110 k Ω \pm 1%, 1/8 W	234 201 485
R6, R97, R99, R103, R107, R109, R110, R114, R116	2 k Ω \pm 1%, 1/8 W	234 201 318
R8	1.6 k Ω \pm 5%, 1/4 W	234 024 068
R9, R12	110 k Ω \pm 5%, 1/4 W	234 024 112
R11	510 Ω \pm 5%, 1/4 W	234 024 056
R13, R125	Thermistor, 1 k Ω , @ 25 C	240 003 019
R14, R46	3.32 k Ω \pm 1%, 1/8 W	234 201 339
R15	46.4 k Ω \pm 1%, 1/8 W	234 201 449
R16	3.01 k Ω \pm 1%, 1/8 W	234 201 335
R17, R41	10 Ω \pm 5%, 1/2 W	234 014 068
R18	330 Ω \pm 5%, 1/4 W	234 024 051
R19, R39, R57, R62, R77, R82, R117, R122, R123, R158–R160	1 k Ω \pm 5%, 1/4 W	234 024 063
R20	10 Ω \pm 5%, 1/4 W	234 024 015

Reference Designator	Description	Valleylab Part Number
R21, R89	2.67 k Ω \pm 1%, 1/8 W	234 201 330
R22, R141	100 k Ω \pm 1%, 1/8 W	234 201 481
R26	6.81 k Ω \pm 1%, 1/8 W	234 201 369
R27	432 Ω \pm 1%, 1/8 W	234 201 254
R28	68.1 k Ω \pm 1%, 1/8 W	234 201 465
R29	90.9 k Ω \pm 1%, 1/8 W	234 201 477
R30	5.11 k Ω \pm 1%, 1/8 W	234 201 357
R31, R56, R60, R61, R87, R91, R92, R93, R147, R163, R164, R170, R171, R173	10 k Ω \pm 1%, 1/8 W	234 201 385
R32, R33, R74, R165, R167, R172	2.15 k Ω \pm 1%, 1/8 W	234 201 321
R34, R35, R75, R166, R168, R169	1.4 k Ω \pm 1%, 1/8 W	234 201 303
R36–R38, R50, R90	2 k Ω \pm 5%, 1/4 W	234 024 070
R40, R58, R63, R78, R145, R152	51 Ω \pm 5%, 1/4 W	234 024 032
R42	12.4 k Ω \pm 1%, 1/8 W	234 201 394
R43, R80, R86, R130, R133	100 Ω \pm 5%, 1/4 W	234 024 039
R47	1.3 k Ω \pm 5%, 1/4 W	234 024 066
R49, R138	6.8 k Ω \pm 5%, 1/4 W	234 024 083
R55	56 k Ω \pm 5%, 1/4 W	234 024 105
R59, R64	9.1 k Ω \pm 5%, 1 W	234 204 030
R65	1 M Ω \pm 1%, 1/8 W	234 201 577
R66	18.2 k Ω \pm 1%, 1/8 W	234 201 410

Reference Designator	Description	Valleylab Part Number
R67	91 k Ω \pm 5%, 1/4 W	234 024 110
R68, R70	Thermistor	240 003 005
R69, R71	30 k Ω \pm 5%, 2 W	234 204 012
R72	274 Ω \pm 1%, 1/8 W	234 201 235
R73, R119, R150	100 k Ω \pm 5%, 1/4 W	234 024 111
R76	390 Ω \pm 5%, 1/4 W	234 024 053
R83, R85, R104, R108, R111, R115	1 k Ω \pm 1%, 1/8 W	234 201 289
R88	100 k Ω \pm 5%, 1/2 W	234 014 122
R94	39 k Ω \pm 5%, 1/2 W	234 014 113
R95	47 Ω \pm 5%, 1/4 W	234 024 031
R100	750 Ω \pm 5%, 1/4 W	234 024 060
R105, R106, R112, R113	499 Ω \pm 1%, 1/8 W	234 201 260
R118	270 k Ω \pm 5%, 1/4 W	234 024 121
R120	68 k Ω \pm 5%, 1/4 W	234 024 107
R124	7.5 Ω \pm 5%, 1/2 W	234 014 065
R126	8.06 k Ω \pm 1%, 1/8 W	234 201 376
R127	150 Ω \pm 1%, 1/8 W	234 201 210
R139	3.9 k Ω \pm 5%, 1/4 W	234 024 077
R140	5.1 k Ω \pm 5%, 1/4 W	234 024 080
R142	100 Ω \pm 1%, 2 W	234 400 276
R143	511 Ω \pm 1%, 1/2 W	234 204 020
R151	15 k Ω \pm 5%, 1/4 W	234 024 091
R153	3.3 k Ω \pm 5%, 1/4 W	234 024 075

Reference Designator	Description	Valleylab Part Number
R154	2.7 k Ω \pm 1%, 1/4 W	234 201 340
R156, R157	10 k Ω \pm 1%, 10 W	234 400 275
R161, R162	5.6 M Ω \pm 1%, 2 W	234 204 013
<i>Transformers</i>		
T1	Pulse dial	251 300 057
T2, T5, T6, T7, T8	Inductor, current sense	251 300 007
T3	Power switching	251 200 105
T4	RF molded 0.3 F3 core	251 200 107
T9, T10, T11	Square core REM	251 300 045
T12	Voltage sense	251 300 044
<i>Integrated Circuits</i>		
U1, U12, U29	MOSFET driver TSC1427	210 800 012
U2, U7, U9, U14, U35, U36	LM 393 N	210 300 011
U3	PWM controller, high speed	210 720 019
U4	MAX 492CPA op-amp	210 100 035
U5	LM339AN	210 300 015
U6	LM358AN	210 300 013
U8	Audio amp LM386	210 400 019
U10	AVS1AC	210 800 018
U11	DC/DC converter HPR107	210 750 007
U13, U18, U19, U23, U24	High speed, low power dual op	210 720 020
U15	Multivibrator 74LS221	210 520 094
U16, U17	2803A	210 800 002

Reference Designator	Description	Valleylab Part Number
U20	LM319	210 410 001
U21, U33	Op-amp TL052A	210 400 020
U22	High speed MOSFET dr 8pd, 9 A	210 800 031
U31	Op-amp LF412	210 400 016
U25	Quad analog switch	210 200 041
U26	Digital control pot, 10 k	210 100 038
U27, U34	4081	210 210 081
U28	Oscillator, precision 74HCT4060	250 010 036
U30	Inverter 74HC14	210 230 004
U32	4093B quad 2 input	210 250 094
<i>Miscellaneous</i>		
Item 2	Assembly, right heat sink	202 750 101
Item 3	Assembly, left front heat sink	202 750 102
Item 4	Assembly, left rear heat sink	202 750 100
Item 5	Sleeving, PVC clear 15 awg	249 014 008
Item 6	Screw, bndhd slt 6-32 x 0.188 stl	237 015 152
Item 7	Screw panhd M3 10 mm (6)	237 050 135
Item 8	Ties, cable and wire (2)	222 004 007
CR7	Socket, pin lg lead dia. (2)	208 500 057
CR17, CR22, CR23, CR36, Q2, Q4, Q5, Q7, Q8, R79, R12	Socket, transistor	208 500 014
D3	Triac power	239 610 023
FB1–FB8	Ferrite bead	251 100 116
HDW1–6	Bracket, PCB mounting	223 400 629

Reference Designator	Description	Valleylab Part Number
HTSK1	Heat sink MDM power	223 400 521
ISO1, ISO2, ISO3	Optoisolator 4N35	239 750 002
J1	Socket	208 500 080
J4	Connector, PCB (4 ckt)	208 160 054
J5	Connector, PCB (7 ckt)	208 160 057
J6, J12	Connector, PCB (3 ckt)	208 160 053
J7	Connector, PCB (6 ckt)	208 160 056
J8	Connector, PCB (5 ckt)	208 160 055
J9	Connector, 90 degree, (9 pins)	208 300 871
J10	Connector, 96 pin	208 300 721
J11	Connector, phone jack	208 400 113
J13	Connector, PC edge	208 157 031
J14	Connector PCB, (8 ckt)	208 160 058
J15, J16	Contact, monopolar	223 500 085
J17, J19–J24	Fuse clip	215 100 078
J18	Contact spring, bipolar	223 500 078
L1	Inductor 0.75 MH	251 100 167
L2, L3	RF choke	251 100 174
OPT1, OPT2, OPT3	Optoisolator, single PCB mount	239 750 073
TP1–T34	Test point	208 200 284
W1, W2	Wire, Teflon, 24 awg, red	255 120 142
W3, W7	Wire, Teflon, 24 awg, yellow	255 120 144
W6	Wire, Teflon, 24 awg, white	255 120 140

