

WarmTouch™

Model WT-5900 Patient Warming System



To obtain information about a warranty, if any, contact Covidien Technical Services at 1.800.635.5267 or your local representative.

Purchase of this instrument confers no express or implied license under any Covidien patent to use the instrument with any patient warming system that is not manufactured or licensed by Covidien.

Table of Contents

1	Safety Information	1- 1
1.1	Overview	1-1
1.2	Warnings	1-2
1.3	Cautions	1-3
2	Introduction	2- 1
2.1	Overview	2-1
2.2	Intended Use	2-1
2.3	Manual Availability	2-1
2.4	Background Information	2-1
2.5	Safety Features	2-2
2.5.1	Customized Warming Therapy	2-2
2.5.2	Automatic Temperature Stepdown	2-2
2.5.3	Automatic Over Temperature Shutdown	2-2
2.5.4	Alarms	2-2
2.5.5	HEPA Filter	2-3
2.5.6	Wheel Locks	2-3
2.6	Symbols	2-4
2.7	Description of the Warming System	2-5
3	Routine Maintenance	3- 1
3.1	Overview	3-1
3.2	HEPA Filter Replacement	3-1
3.3	Power Cord Replacement	3-3
3.4	Nozzle Replacement	3-4
3.5	Cleaning the Warming System	3-5
4	Performance Verification	4- 1
4.1	Overview	4-1
4.2	Power Fail / Start Alarm Check	4-1
4.3	Thermostat Protection Check	4-2
4.4	Output Temperature Check	4-4
4.5	Safety Tests	4-6
5	Repair	5- 1
5.1	Overview	5-1
5.2	Filter Cover Assembly Replacement	5-2
5.3	Separating the Front and Rear Covers	5-3
5.4	Rejoining the Front and Rear Covers	5-5
5.5	Front Cover Assembly Replacement	5-7
5.6	Control PCBA Replacement	5-14
5.7	Heater Assembly Replacement	5-18
5.8	Hose Replacement	5-30
5.9	Duct Adapter Assembly Replacement	5-31
5.10	Rear Cover Assembly Replacement	5-35
6	Spare Parts & Accessories	6- 1
6.1	Overview	6-1
6.2	Ordering Information	6-1
6.3	Replacement Parts and Accessories	6-4
6.4	Manual Availability	6-4
7	Packing for Shipment	7- 1
7.1	Overview	7-1
7.2	Returning the Warming System	7-1

7.3	Repacking in Original Carton	7-1
7.4	Repacking in a Different Carton	7-3
8	Specifications	8- 1
8.1	Overview	8-1
8.2	Warming System Specifications	8-1
8.3	Transport and Shipping in Shipping Container	8-2
8.4	Compliance	8-2
8.5	Manufacturer's Declaration	8-2
8.6	Electromagnetic Compatibility (EMC)	8-3
	8.6.1 Electromagnetic Emissions	8-3
	8.6.2 Electromagnetic Immunity	8-3
8.7	Ground Integrity Test	8-5
8.8	Earth Leakage Current Test	8-6
8.9	Enclosure Leakage Current Test	8-6
9	Principles of Operation	9- 1
9.1	Overview	9-1
9.2	Control Panel	9-1
9.3	Main Circuit Board	9-2
	9.3.1 DC Power Supply Circuit	9-2
	9.3.2 Control Logic Circuit	9-2
	9.3.3 Automatic Temperature Stepdown.	9-3
	9.3.4 Alarm Drive Circuits	9-3
	9.3.5 Temperature Control Circuit.	9-3
	9.3.6 LCD Hour Meter.	9-3
	9.3.7 Blower	9-4
	9.3.8 Heater	9-4
	9.3.9 Thermostat Protection	9-4
	9.3.10 Over-Temperature Test Port	9-4
A	Appendix	A- 1

Figures

Figure 2-1.	Cart Wheel Lock	2-3
Figure 2-2.	Front View	2-5
Figure 2-3.	Back View	2-6
Figure 3-1.	Operating Hours Meter	3-2
Figure 3-2.	Filter Cover Screws	3-2
Figure 3-3.	HEPA Filter and Power Cord Strain Relief	3-3
Figure 3-4.	Power Cord Routing	3-4
Figure 4-1.	Over-Temperature Test Port	4-3
Figure 4-2.	WarmTouch Boost Temperature Setting	4-3
Figure 4-3.	Warning Light	4-4
Figure 4-4.	Output Temperature Test Setup	4-5
Figure 4-5.	Temperature Selection	4-5
Figure 4-6.	Ground Stud	4-6
Figure 5-1.	Power Cord	5-2
Figure 5-2.	Filter Cover Screws	5-3
Figure 5-3.	Power Cord	5-4
Figure 5-4.	Cover Screw Locations	5-4
Figure 5-5.	Separated Covers	5-5
Figure 5-6.	Cover Screw Locations	5-6
Figure 5-7.	Cable Harness Bundle Ties	5-8
Figure 5-8.	Front Cover Assembly	5-8
Figure 5-9.	Power Switch Clips and Wires	5-9
Figure 5-10.	Cable Disconnect	5-9
Figure 5-11.	Control PCB Screws	5-10
Figure 5-12.	Control PCB Lights	5-11
Figure 5-13.	Control PCB Screws	5-11
Figure 5-14.	Cable Connections	5-12
Figure 5-15.	Power Switch Clips and Wires	5-12
Figure 5-16.	Front Cover Assembly Component Locations	5-13
Figure 5-17.	Equipotential Ground Stud Wiring	5-13
Figure 5-18.	Cable Harness Bundle Ties	5-14
Figure 5-19.	Control PCB Connections	5-15
Figure 5-20.	Control PCB Lights	5-16
Figure 5-21.	Control PCB Screws	5-16
Figure 5-22.	Cable Connections	5-17
Figure 5-23.	Cable Harness Ties	5-17
Figure 5-24.	Filter Removal	5-19
Figure 5-25.	Blower Assembly Screws	5-19
Figure 5-26.	Cable Harness Bundle Ties	5-20
Figure 5-27.	Front Cover Assembly	5-21
Figure 5-28.	Duct Adapter Placement	5-22
Figure 5-29.	Blower Motor Removal	5-22
Figure 5-30.	Blower Assembly Clips	5-23
Figure 5-31.	Rubber Gasket	5-23
Figure 5-32.	Heater Assembly	5-24
Figure 5-33.	Heater Assembly Installation	5-25

Figure 5-34.	Rubber Gasket	5-25
Figure 5-35.	Blower Assembly Clips	5-26
Figure 5-36.	Duct Adapter Placement	5-27
Figure 5-37.	Blower Assembly Screws	5-28
Figure 5-38.	Cable Harness Bundle Ties	5-28
Figure 5-39.	Filter Installation	5-29
Figure 5-40.	Filter Cover Installation	5-29
Figure 5-41.	Thermistor Silicone	5-32
Figure 5-42.	Thermistor Removal	5-32
Figure 5-43.	Duct Adapter Removal	5-33
Figure 5-44.	Duct Adapter Placement	5-34
Figure 5-45.	Thermistor Position Within Duct Adapter	5-34
Figure 5-46.	Filter Cover Screws	5-36
Figure 5-47.	Filter Removal	5-36
Figure 5-48.	Separated Covers	5-37
Figure 5-49.	Front Cover Assembly	5-38
Figure 5-50.	Cable Disconnect	5-39
Figure 5-51.	Thermistor Cable Removal	5-39
Figure 5-52.	Blower Assembly Screws	5-40
Figure 5-53.	Blower Capacitor	5-40
Figure 5-54.	Blower Motor Removal	5-41
Figure 5-55.	Blower Assembly Clips	5-42
Figure 5-56.	Rubber Gasket	5-42
Figure 5-57.	Heater Assembly	5-43
Figure 5-58.	Heater Assembly Installation	5-43
Figure 5-59.	Rubber Gasket	5-44
Figure 5-60.	Blower Installation	5-44
Figure 5-61.	Blower Screws	5-45
Figure 5-62.	Thermistor Cable Installation	5-45
Figure 5-63.	Capacitor Installation	5-46
Figure 5-64.	Cable Connections	5-46
Figure 5-65.	Front Cover Assembly	5-47
Figure 5-66.	Equipotential Ground Stud Wiring	5-48
Figure 5-67.	Cable Harness Bundle Ties	5-48
Figure 5-68.	Filter Installation	5-49
Figure 5-69.	Filter Cover Installation	5-49
Figure 6-1.	Spare Parts (Sheet 1)	6-3
Figure 6-2.	Spare Parts (Sheet 2)	6-4
Figure 7-1.	Packing the Warming System in Original Carton	7-2
Figure 9-1.	Control Panel	9-1
Figure 9-2.	Hour MeterAC Power Section	9-4
Figure A-1.	Warming System Schematic (Sheet 1)	A-1
Figure A-2.	Warming System Schematic (Sheet 2)	A-2

Tables

Table 2-1:	Symbols on the Warming System	2-4
Table 3-1:	Equipment Required for HEPA Filter Replacement	3-1
Table 4-1:	Equipment Required for Thermostat Protection Check	4-2
Table 4-1:	Equipment Required for Output Temperature Check	4-4
Table 5-1:	Filter Cover Assembly Components	5-2
Table 5-2:	Tools Required for Replacing Filter Cover Assembly	5-2
Table 5-3:	Tools Required for Separating Front and Rear Covers	5-3
Table 5-4:	Filter Cover Assembly Components	5-7
Table 5-5:	Tools Required for Replacing Front Cover Assembly	5-7
Table 5-6:	Tools Required for Replacing Control PCB	5-14
Table 5-7:	Heater Assembly Components	5-18
Table 5-8:	Tools Required for Replacing Heater Assembly	5-18
Table 5-9:	Hose Assembly Components	5-30
Table 5-10:	Tools Required for Replacing Hose Assembly	5-30
Table 5-11:	Duct Adapter Assembly Components	5-31
Table 5-12:	Tools Required for Replacing Duct Adapter Assembly	5-31
Table 5-13:	Rear Cover Assembly Components	5-35
Table 5-14:	Tools Required for Replacing Rear Cover Assembly	5-35
Table 6-1:	Spare Parts and Accessories	6-2
Table 8-1:	System Specifications	8-1
Table 8-2:	Shipping Container Specifications	8-2
Table 8-3:	Compliance Standards	8-2
Table 8-4:	Electromagnetic Emissions Guidelines	8-3
Table 8-5:	Electromagnetic Immunity Guidelines	8-3
Table 8-6:	Recommended Separation Distances	8-5
Table 8-7:	Earth Leakage Current Test	8-6
Table 8-8:	Enclosure Leakage Current Test	8-6

This page is intentionally blank.

Safety Information

1.1 Overview

This chapter contains safety information requiring users to exercise appropriate caution when servicing the WarmTouch™ Model WT-5900 patient warming system.



Warning

The WARNING symbol identifies warnings.

Warnings alert the user to potential serious outcomes, such as death, injury, or adverse events to the patient or user.



Caution

The CAUTION symbol identifies cautions.

Cautions alert the user to exercise care necessary for the safe and effective use of the warming system.



NOTE:

The NOTE symbol identifies notes.

Notes contain important information that may otherwise be overlooked or missed.

1.2 Warnings



Warning

Possible explosion hazard. Do not use the WarmTouch™ Model WT-5900 patient warming system in the presence of flammable anesthetic agents.



Warning

Possible electrical shock hazard. Do not open or disassemble the warming system. If a malfunction occurs, please notify your sales/service center.



Warning

Possible electric shock hazard. Grounding reliability can be achieved only when the warming system is connected to a suitable mains outlet.



Warning

Possible fire hazard. Prevent the blanket material from coming into contact with a laser or an electrosurgical active electrode; rapid combustion could result.



Warning

Possible burn hazard. Do not apply heat directly to open wounds. All patient's wounds should be covered while using the warming system.



Warning

Possible patient burns. Use caution and consider discontinuing use on patients during vascular surgery when an artery to an extremity is clamped. Do not apply the warming system to ischemic limbs. This could possibly cause the patient to be burned.



Warning

Possible patient burns. Use caution and monitor closely if used on patients with severe peripheral vascular disease. This could possibly cause the patient to be burned.



Warning

No free-hosing. Keep hose nozzle connected to a WarmTouch™ blanket at all times or thermal injury may occur.



Warning

WarmTouch™ blankets are for single patient use only.



Warning

The warming system should not be operated in the presence of electromagnetic fields that are greater than three Volts per meter. This could

cause shutdown of the warming system by the fail-safe function within the equipment.

**Warning**

The warming system is not suitable for use during magnetic resonance imaging (MRI) scanning. The warming system may affect the MRI image.

**Warning**

Continuously monitor the patient's temperature. Reduce the air temperature or discontinue therapy when normothermia is reached.

**Warning**

Before attempting to open or disassemble the warming system, disconnect the power cord from the AC power source.

1.3 Cautions

**Caution**

The warming system is fitted with an air filter; however, airborne contamination should be considered when using the warming system.

**Caution**

If the warming system is mounted on the intravenous (IV) pole, it should be installed with the top of the unit's handle less than 76 cm (30 inches) above the floor to prevent the IV pole from tipping over.

**Caution**

If a malfunction occurs in the warming system, discontinue use. Notify your sales/service center of the malfunction. The unit must be serviced by an authorized service technician.

**Caution**

The institution should follow local governing ordinances and recycling instructions regarding disposal or recycling of filter and device components or end of life of the product.

**Caution**

The HEPA filter **must** be changed every 2,000 hours of operation. Refer to the *Routine Maintenance* section for replacement procedures requiring a qualified technician.

**Caution**

Do not spray, pour, or spill any liquid on the warming system, its accessories, connectors, switches, or openings in the case.



Caution

Ensure the patient is dry or the warming system may be ineffective.



Caution

Observe ESD (electrostatic discharge) precautions when working within the warming system.



Caution

Repairs to the warming system should only be accomplished by trained service technicians.

Introduction

2.1 Overview

This chapter provides an introduction to the WarmTouch™ Model WT-5900 patient warming system.

2.2 Intended Use

The WarmTouch™ Model WT-5900 patient warming system (warming unit and blanket) is intended for prevention and treatment of hypothermia. For example, with the surgical patient, the patient in the preoperative holding area, the pregnant woman who shivers during epidural anesthesia due to hypothermia, or any patient who is uncomfortable in the cold critical care environment.

2.3 Manual Availability

The most recent revision of this manual is available on the Internet at:
<http://www.respiratorysolutions.covidien.com>

2.4 Background Information

There are numerous ways of warming your patient, from cotton blankets to water mattresses. Research has shown that low temperatures surrounding the patient are a major factor contributing to hypothermia.^{1,2} The warming system covers the patient with warm air and actively transfers heat across the skin. The result is to achieve normothermia.

In creating this warm customized pocket of air around the hypothermic patient, it is important to note that stagnant air, even if it is warm, does not work as an effective heat transfer medium. Stagnant air acts as an insulator, preventing the boundary layer of molecules next to the skin surface from transferring heat.

Forced air warming causes warmed air molecules to flow over cooler skin surface. It is this active flow of warmed molecules that acts as a heat transfer medium.

1. Morris RH, Wilkey BR. "The Effects of the Ambient Temperature on Patient Temperature During Surgery Not Involving Body Cavities." *Anesthesiology* 32:102-107, 1970.

2. Morris RH. "Influence of Ambient Temperature on Patient Temperature During Intra-abdominal Surgery." *Annals of Surgery* 173:230-233, 1971.

With the warming system, air is warmed and delivered into a lightweight blanket that rests over or under the patient. The blankets have many small perforations on the underside that allow air to exit the blanket and surround the patient.

2.5 Safety Features

The warming system is designed to give healthcare professionals more control over the patient's core body temperature. There are several safety features of the warming system which make it safe and appropriate for such use.

2.5.1 Customized Warming Therapy

Clinicians select a temperature range setting at the onset of warming therapy to help ensure the appropriate setting is selected for every patient.

2.5.2 Automatic Temperature Stepdown

The warming system provides a 45-minute temperature stepdown feature. When in Boost Mode, blower temperature will automatically drop to the high temperature setting after each 45 minutes of use. The temperature may be reset to Boost Mode by selecting the boost temperature setting on the control panel to start another 45-minute cycle.

2.5.3 Automatic Over Temperature Shutdown

The automatic temperature controller and two back-up systems help ensure the temperature will not reach excessive levels. If necessary, the control system automatically turns off the heater element when the blower outlet temperature rises to between 47°C and 50°C, illuminates the flashing warning light, and sounds an audible alarm. The warming system heater will start producing heat when the warming system temperature drops to between approximately 34°C and 37°C. A yellow warning light illuminates whenever the control system identifies an over-temperature condition.

2.5.4 Alarms

The WarmTouch control circuit manages and monitors operation of the patient warming system. Should the control circuit encounter a failure condition, it reports failures using both visual and audible alarms. The visual alarm is a yellow warning indicator on the control panel that lights at power on, upon power restoration following power failure, and whenever the control system identifies an alarm condition. The audible alarm sounds intermittently or continuously, depending on the alarm condition. Investigate immediately.

The WarmTouch™ control circuit recognizes two failure conditions.

1. **Power On/Power Fail Alarm** — This condition causes an intermittent audible alarm and continuous visual alarm. It appears at power on and after power failure, indicating the operator must select the desired temperature. Upon selection of a temperature key, the system cancels the alarm and the blower operates at the desired temperature.
2. **Over-temperature Alarm** — This condition causes a continuous audible alarm and a flashing visual alarm. It appears when reaching the temperature safety limit, and the control system turns off the heater. Once the system air temperature returns to a safe operating temperature of between 34°C and 37°C, the heater will turn back on.

If the control system determines the heater again exceeds the safety limit, the warming system alarms once more. Take the warming system out of service for repair by a qualified service technician.

If a power failure occurs while the warming system is in the over-temperature fault condition, and the warming system is still in the over-temperature fault condition when power is restored, continuous audible and visual alarms will activate. In this instance, the

over-temperature fault cannot be cleared. Take the warming system out of service for repair by a qualified service technician.

2.5.5 HEPA Filter



Caution

The HEPA filter **must** be changed every 2,000 hours of operation. Refer to the *Routine Maintenance* section for replacement procedures requiring a qualified technician.

The system's High Efficiency Particulate Air Filter is 99.97% efficient at 0.3-micron particle size.

2.5.6 Wheel Locks

The cart is equipped with two wheel locks. The wheel locks prevent the cart from moving while in use. The wheel locks must be released when moving the cart. Press the wheel lock arm down to lock the wheel. Lift the wheel lock arm to release the wheel lock. See Figure 2-1.









Figure 2-1. Cart Wheel Lock

2.6 Symbols

The symbols identified in Table 2-1 are the symbols used on the WT-5900 and all WT-5900 labeling.

Table 2-1: Symbols on the Warming System

	Attention symbol, consult accompanying documentation.
	Do not direct air from the hose to the patient (free-hosing); use hose only with warming blankets.
	Dangerous voltage
	Protection Class I Protection Type BF
	Date of manufacture
	Visual and audible alert

2.7 Description of the Warming System

The warming system (Figure 2-2 and Figure 2-3) and blankets are intended for prevention and treatment of hypothermia. For example, use the warming system with the surgical patient, the patient in the preoperative holding area, the pregnant woman who shivers during epidural anesthesia due to hypothermia, or any patient who is uncomfortable in the cold critical care environment.



- | | | | |
|---|-------------------|---|---------------|
| 1 | Hose | 4 | Power Cord |
| 2 | Main Power Switch | 5 | Hour meter |
| 3 | Nozel | 6 | Control Panel |

Figure 2-2. Front View

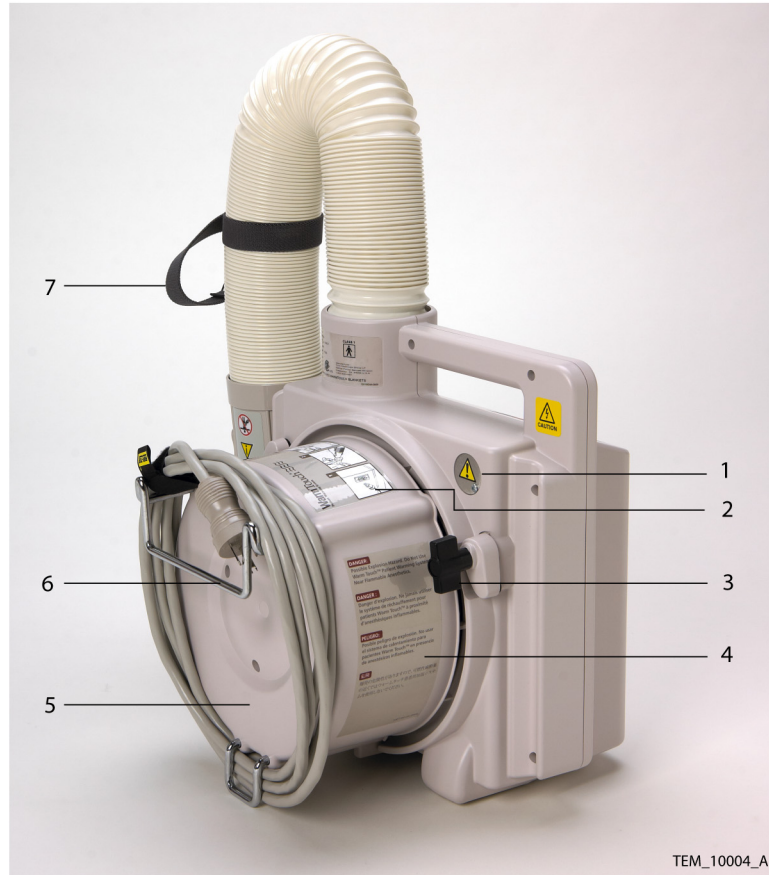

- | | | | |
|----------|-----------------------------------|----------|-------------------------------|
| 1 | Over-Temperature Test Port | 5 | Filter Cover |
| 2 | Instruction Label | 6 | Bed Hook Bracket |
| 3 | Blower Cart Clamp | 7 | Nozzle Strap with Clip |
| 4 | Warning Label | | |

Figure 2-3. Back View

Routine Maintenance

3.1 Overview

This chapter provides routine maintenance procedures for the WarmTouch™ Model WT-5900 patient warming system.



Caution

The institution should follow local governing ordinances and recycling instructions regarding disposal or recycling of filter and device components or end of life of the product.

3.2 HEPA Filter Replacement

The warming system filter **must** be replaced after every 2,000 hours of use. Contact Covidien's Customer Service Department (1.800.635.5267, press 3 in the U.S.A.) or your local Covidien representative to purchase new filters. The correct filter will be sent to your hospital for installation.



Caution

Only qualified hospital personnel should replace the air filter.

Table 3-1: Equipment Required for HEPA Filter Replacement

Equipment	Description / Use
Phillips screwdriver	#2 / Removing screws
Replacement filter	P/N 505-2200
Flat blade screwdriver	Detaching power cord from filter cover



Warning

Do not operate the warming system with the back cover removed.



NOTE:

To read the operating hours meter, the warming system must be running.

To replace the HEPA filter:

1. Write the date and total hours of operation of the warming system on the new filter label and warming system label. The operating hours meter is on the front of the warming system (see Figure 3-1).



Figure 3-1. Operating Hours Meter

2. Unplug the warming system.
3. Lay the warming system on its front side so that the bottom of the warming system is visible.
4. Unwrap the power cord from the filter cover.
5. Remove the filter cover screws. See Figure 3-2.

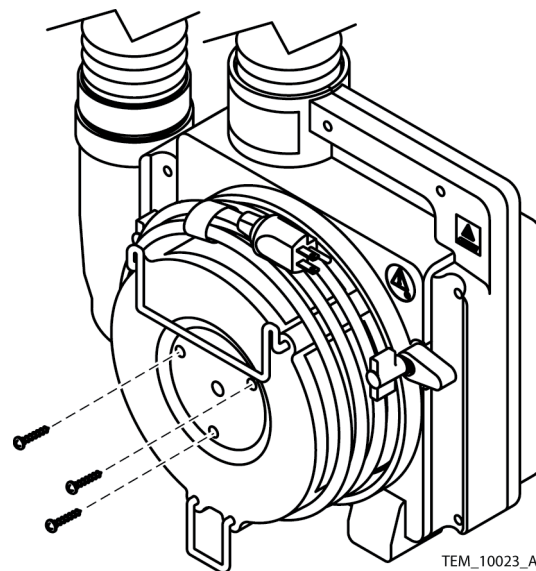
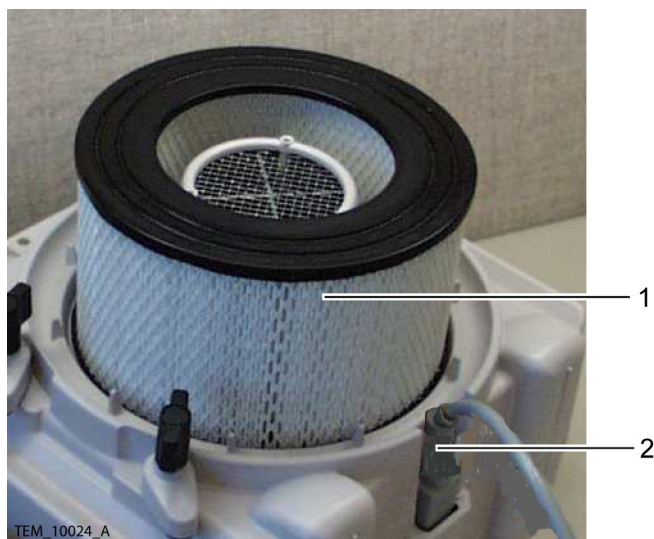

Figure 3-2. Filter Cover Screws

Unseat the power cord from the power cord routing bracket on the filter cover. If necessary, use the head of the flat blade screwdriver to separate the halves of the bracket sufficiently to allow unseating of the cord.

6. Remove the filter cover.
7. Remove the filter. See Figure 3-3.



1 HEPA Filter

2 Power Cord Strain Relief

Figure 3-3. HEPA Filter and Power Cord Strain Relief

8. Place the new filter into the warming system.
9. Ensure that the power cord's female connector is still fully inserted into the socket in the warming system housing.
10. Place the filter cover on the case and reseal the power cable into the power cable routing bracket on the bottom of the cover.
11. Align the filter cover with the three screw holes in the filter and install the three screws holding the filter cover to the warming system.
12. Attach the completed replacement filter label to the rear surface of the filter cover. If a replacement filter label is already present, cover it with the new label.

3.3 Power Cord Replacement

The warming system is equipped with a detachable power cord. If the power cord is damaged, contact your local Covidien representative.



Caution

Only qualified hospital personnel should replace the power cord.

The only equipment required for this procedure is a flat blade screwdriver.

To replace the power cord:

1. Unplug the warming system power cord from the AC outlet.
2. Lay the warming system on its rear side so that the bottom of the warming system is visible.

3. Unwind the power cord from the filter cover.
4. Unseat the power cord from the power cord routing bracket (Figure 3-4, item 4) on the filter cover. If necessary, use the head of the flat blade screwdriver to separate the halves of the bracket sufficiently to allow unseating of the cord.
5. Disconnect the power cord connector (Figure 3-4, item 2) from its socket in the blower housing.

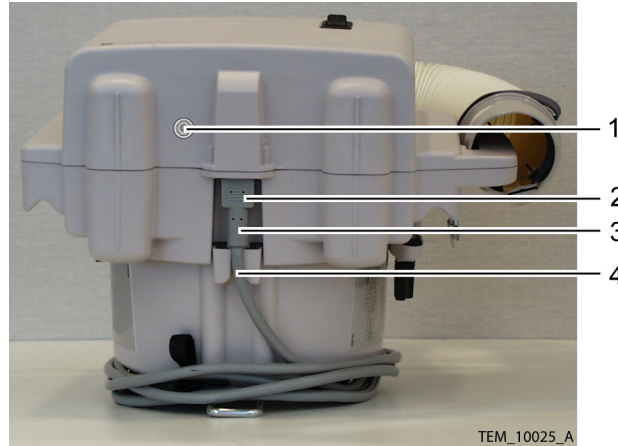

- | | |
|--|--|
| <p>1 Equipotential Ground</p> <p>2 Power Cord Female Connector</p> | <p>3 Strain Relief</p> <p>4 Power Cord Routing Bracket</p> |
|--|--|

Figure 3-4. Power Cord Routing

6. Connect the replacement power cord connector to the warming system, making sure the connector is fully inserted into the socket in the warming system housing.
7. Reseat the power cord into the power cord routing bracket. If necessary, use the head of the flat blade screwdriver to separate the halves of the bracket sufficiently to allow reseating of the cord.

3.4 Nozzle Replacement

If the nozzle is damaged, contact your Covidien representative.

The only equipment required for this procedure is a flat blade screwdriver. The nozzle is held in place at its base by four clips on the hose assembly; make sure the screwdriver is long enough to reach inside the nozzle to the clips.

To replace the nozzle:

1. Insert the screwdriver blade into the nozzle, positioning it between one of the clips and the inner surface of the nozzle.
2. Use the screwdriver blade to push the clip in toward the center of the nozzle, while simultaneously pulling the nozzle away from the hose until the clip is disengaged from the base of the nozzle.
3. Repeat steps 1 and 2 to disengage the other three clips.
4. Remove the nozzle from the hose.
5. Put the replacement nozzle over the end of the hose.
6. Push the replacement nozzle down onto the hose until all four clips engage with the nozzle.

3.5 Cleaning the Warming System

**Caution**

Do not spray, pour, or spill any liquid on the warming system, its accessories, connectors, switches, or openings in the case.

For surface cleaning and disinfection of the warming system, follow your institution's procedures or the recommended actions below.

- **Surface cleaning** — Use a soft cloth dampened with either a commercial, nonabrasive cleaner or a solution of 70% alcohol in water, lightly wiping the surfaces of the warming system.
 - **Disinfection** — Use a soft cloth saturated with a solution of 10% chlorine bleach in tap water, lightly wiping the surfaces of the warming system.
-

This page is intentionally blank.

Performance Verification

4.1 Overview

This chapter provides performance verification procedures to be used when servicing the WarmTouch™ Model WT-5900 patient warming system

4.2 Power Fail / Start Alarm Check

This procedure ensures the Power Fail / Start Alarm functions correctly and can be canceled properly. Perform this procedure before returning the warming system into service



NOTE:

The Power Fail / Start Alarm is only found on warming systems containing a PCBA with part number GR100306. Warming systems with earlier versions of the Control PCBA (referred to as the Universal PCBA in earlier versions of this manual) do not have this alarm, and do not need this test.

At power up, both audible and visual alarms activate, regardless of the reason for power loss. Selecting any blower temperature cancels both types of alarms.

No equipment is required for this check.

To check the Power Fail / Start Alarm:

1. Plug in the warming system.
2. Turn on the warming system using the power switch. The audible alarm should sound intermittently, and the warning light should be on steady. The Low temperature indicator light on the control panel should also be on steady.
3. Select any temperature setting. The audible alarm should stop, and the warning light should turn off. The indicator light for the selected temperature should be on steady.
4. Turn off the warming system and unplug it.

4.3 Thermostat Protection Check

This procedure checks to ensure that the thermostat protection controls are working properly. This procedure should be performed before returning the warming system into service.

Calibration of the thermostat protection is neither required nor possible. If the test time or temperatures are outside the allowable range, factory service is required. Contact your local Covidien representative.

Table 4-1: Equipment Required for Thermostat Protection Check

Equipment	Description / Use
Temperature probe	Mon-a-Therm™ subcutaneous temperature probe, or equivalent, and monitor with an accuracy of $\pm 0.2^{\circ}\text{C}$.
Tape	To hold the temperature probe in place.
Stopwatch	Manual or electronic
Jumper wire with alligator clips	3 to 12 in (8 to 30 cm) long, alligator clip at each end, 12 gauge minimum.
Phillips screwdriver	#2 / Loosening and tightening test port screw.
WarmTouch lower body blanket	To complete patient warming system.

To check thermostat protection:

1. Lay the temperature probe beside the warming system nozzle at the end of the hose and bend approximately 1.5 inches (4 cm) of the temperature probe into the nozzle opening.
2. Position the tip of the temperature probe approximately 1 to 2 in (2.5 to 5 cm) inside the nozzle, centered in the nozzle opening.
3. Tape the probe in place.
4. Connect the probe to the temperature monitor.
5. Connect the nozzle to the blanket.
6. Unplug the warming system.
7. Loosen the over-temperature test port screw. See Figure .
8. Slide the over-temperature test port cover to the side.

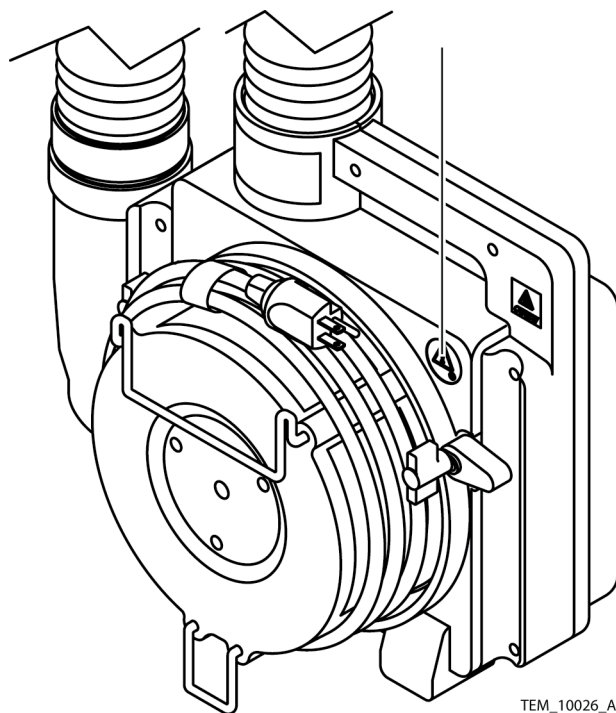

Figure 4-1. Over-Temperature Test Port



Warning

Possible patient injury. Connecting the jumper wire disables (shorts out) the thermistor that is part of the temperature control system.

9. Connect the jumper wire across the two terminals in the over-temperature test port.
10. Plug in the warming system and turn it on.
11. Select the Boost temperature setting. See Figure 4-2.

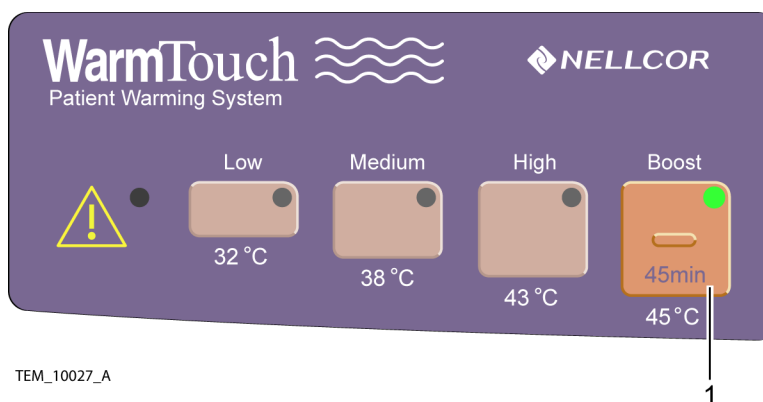

Figure 4-2. WarmTouch Boost Temperature Setting

12. When the monitored temperature exceeds 46°C, start the stopwatch.
13. When the alarm starts to sound and the warning light indicator lights, stop the stopwatch. See Figure 4-3.

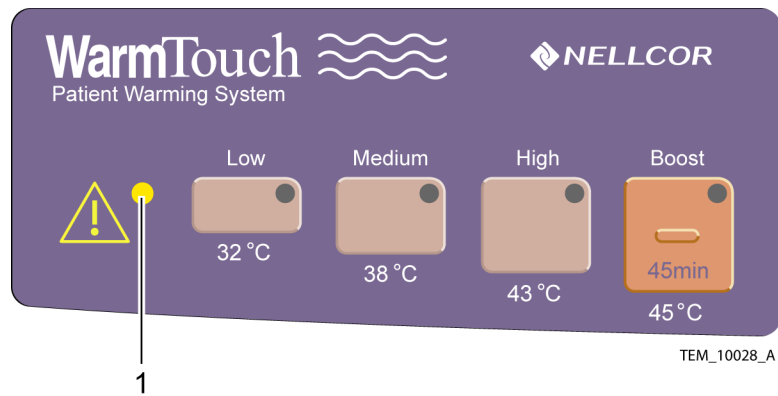

Figure 4-3. Warning Light

14. Time elapsed on the stopwatch should be 5 minutes or less, and the temperature monitor should not exceed 58°C.
15. Turn off the warming system and unplug it.



Warning

Possible patient injury. Connection of the jumper wire disables (shorts out) the thermistor that is part of the temperature control system. The jumper wire must be removed.

16. Remove the jumper wire from the over-temperature test port. See Figure .
17. Close the over-temperature test port and tighten the screw.
18. Disconnect the warming system from the blanket.
19. Allow the warming system to cool for 30 minutes before using the warming system on a patient.

4.4 Output Temperature Check

This procedure measures the warming system output air temperature at the input to the blanket. This procedure should be accomplished before returning the warming system into service.

Calibration of the temperature control circuit is neither required nor possible. If the test temperatures are outside the allowable range, factory service is required. Contact your local Covidien representative.

Table 4-1: Equipment Required for Output Temperature Check

Equipment	Description/Use
Temperature Probe	Mon-a-Therm™ subcutaneous temperature probe, or equivalent, and monitor with an accuracy of $\pm 0.2^{\circ}\text{C}$.
Tape	To hold the temperature probe in place.
WarmTouch lower body blanket	To complete patient warming system.

To check output temperature:

1. Lay the temperature probe alongside the warming system nozzle at the end of the hose and bend approximately 1.5 in (4 cm) of the temperature probe into the nozzle opening.
2. Position the tip of the temperature probe so that it is approximately 1 to 2 in (2.5 to 5cm) inside the nozzle, centered in the nozzle opening.
3. Tape the probe in place.
4. Connect the probe to the temperature monitor.
5. Connect the nozzle to the blanket.
6. Extend the warming system hose to match the configuration shown in Figure 4-4.

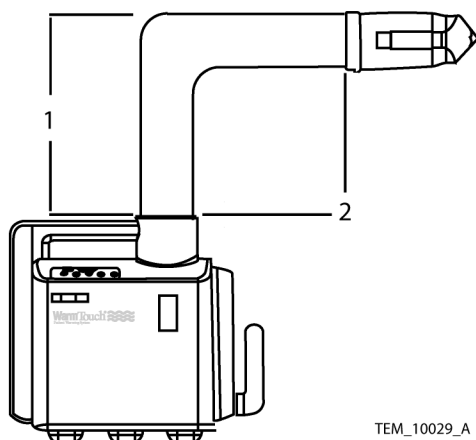

TEM_10029_A

1 14 to 16 in (35.6 to 40.6 cm) 2 28 to 30 in (71.1 to 76.2 cm)

Figure 4-4. Output Temperature Test Setup

7. Turn on the warming system.
8. Select the Low temperature setting (Figure 4-5, item 1).

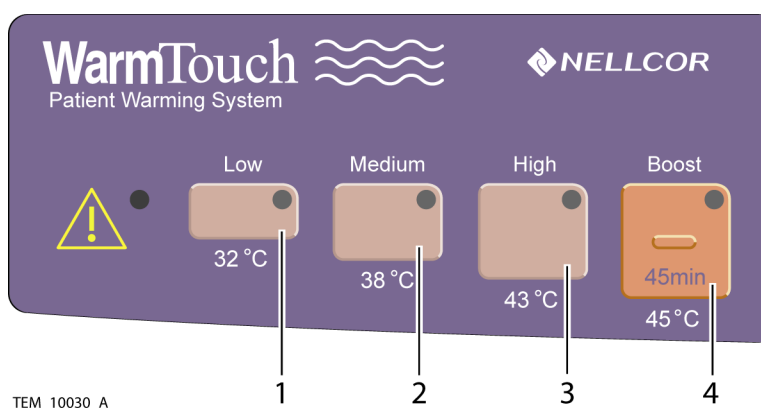

TEM_10030_A

1 Low Temperature Select 3 High Temperature Select
 2 Medium Temperature Select 4 Boost Temperature Select

Figure 4-5. Temperature Selection

9. Allow 8 to 10 minutes for the temperature to stabilize at the Low setting. The temperature monitor should indicate 30°C to 34°C.
10. Select the Medium temperature setting (Figure 4-5, item 2).
11. Allow 8 to 10 minutes for the temperature to stabilize at the Medium setting. The temperature monitor should indicate 36°C to 40°C.
12. Select the High temperature setting (Figure 4-5, item 3).
13. Allow 8 to 10 minutes for the temperature to stabilize at the High setting. The temperature monitor should indicate 41°C to 45°C.
14. Select the Boost temperature setting (Figure 4-5, item 4).
15. Allow 8 to 10 minutes for the temperature to stabilize at the Boost setting. The temperature monitor should indicate 44°C to 46°C.
16. Turn off the warming system and unplug it.
17. Disconnect the warming system nozzle from the blanket.
18. Remove the temperature probe from the warming system nozzle.

4.5 Safety Tests

The warming system is provided with a ground stud to allow safety testing without opening the case. See Figure 4-6.

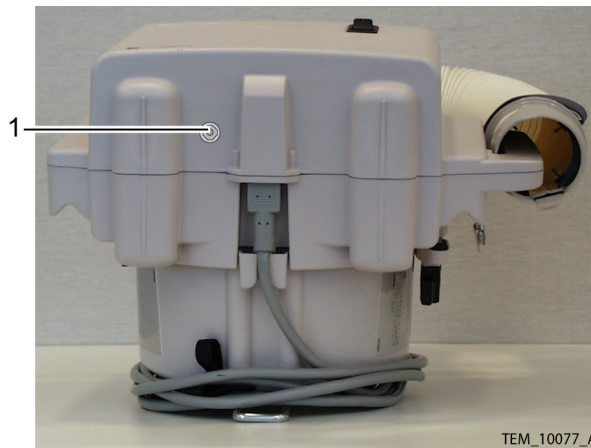

Figure 4-6. Ground Stud



NOTE:

Use applicable standards for institution and country. Test equipment and its application must comply with the applicable standard.

To perform safety tests:

- Test ground integrity. See page 99 for test values.
- Test earth leakage current. See page 100 for test values.
- Test enclosure leakage current. See page 100 for test values.

Repair

5.1 Overview

This chapter provides procedures for servicing the WarmTouch™ Model WT-5900 patient warming system.



Warning

Before attempting to open or disassemble the warming system, disconnect the power cord from the AC power source.



Caution

Observe ESD (electrostatic discharge) precautions when working within the warming system.



Caution

Repairs to the warming system should only be accomplished by trained service technicians.

Follow local government ordinances and recycling instructions regarding the disposal of the warming system and/or parts.

5.2 Filter Cover Assembly Replacement

Table 5-1: Filter Cover Assembly Components

Qty	Component
1	Filter cover
1	Bed hook
1	Foot, filter cover, short
4	Truss HD screws (8-32)
1	Gasket, WarmTouch
1	Operating instructions label
1	Grounding reliability label

Table 5-2: Tools Required for Replacing Filter Cover Assembly

Tool	Parameter / Use
Phillips screwdriver	#2 / Removing screws.
Torque driver	8 to 12 in/lbs (20 to 30 cm/kg)
Flat blade screwdriver	Detaching filter cover from power cord.

To replace the filter cover assembly:

1. Unplug the warming system power cord from the AC outlet.
2. Lay the warming system on its front side, so that the bottom of the warming system is visible.
3. Unwind the power cord from the filter cover. See Figure 5-1.

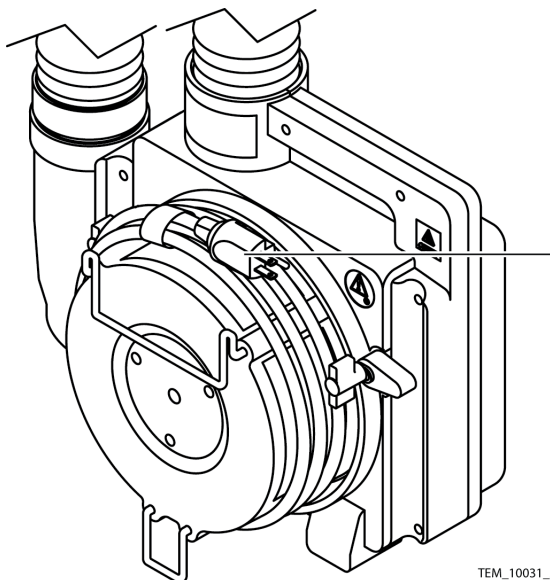

Figure 5-1. Power Cord

4. Unseat the power cord from the power cord routing bracket on the filter cover. If necessary, use the head of the flat blade screwdriver to separate the halves of the bracket sufficiently to allow unseating of the cord.
5. Disconnect the power cord connector from the warming system.
6. Remove the filter cover screws. See Figure 5-2.

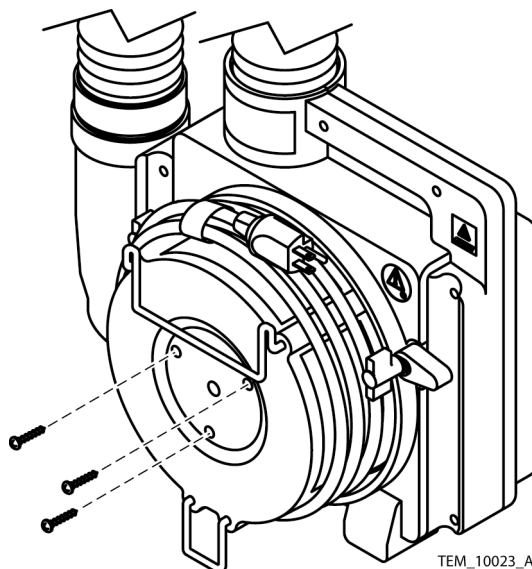

Figure 5-2. Filter Cover Screws

7. Remove the filter cover assembly from the warming system.
8. Place the replacement filter cover assembly on the warming system and install the screws. Tighten the screws to 8 to 12 in/lbs (20 to 30 cm/kg). See Figure 5-2.
9. Reconnect the power cord to the warming system. Ensure the connector is fully inserted into the socket on the blower housing.

5.3 Separating the Front and Rear Covers

Table 5-3: Tools Required for Separating Front and Rear Covers

Tool	Parameter / Use
Phillips screwdriver	#2 / Removing screws.
Flat blade screwdriver	Detaching power cord from filter cover.

To separate the warming system covers:

1. Unplug the warming system power cord from the AC outlet.
2. Lay the warming system on its front side, so that the bottom of the warming system is visible.
3. Unwind the power cord from the filter cover. See Figure 5-3.

4. Unseat the power cord from the power cord routing bracket on the filter cover. If necessary, use the head of the flat blade screwdriver to separate the halves of the bracket sufficiently to allow unseating of the cord.

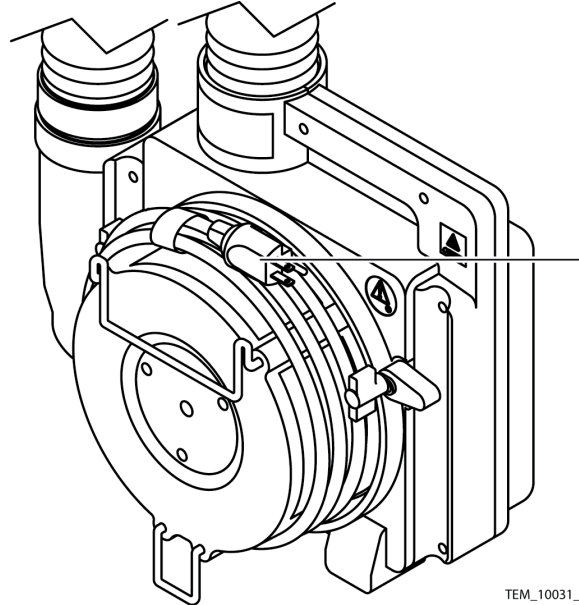

TEM_10031_A

Figure 5-3. Power Cord

5. Disconnect the power cord connector from the warming system.
6. Remove the screws holding the front and rear covers together. See Figure 5-4.

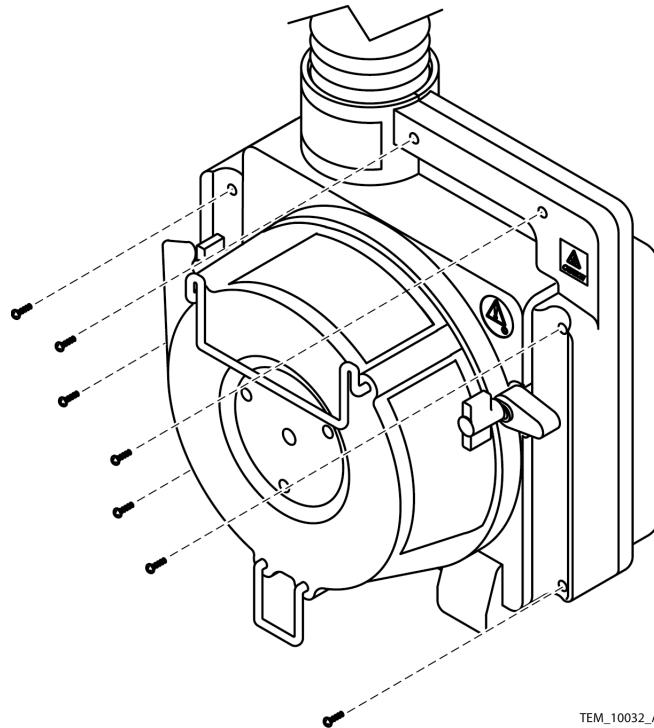

TEM_10032_A

Figure 5-4. Cover Screw Locations

**Caution**

Separate the front and rear covers very carefully. Do not apply too much pressure to the wires connecting the covers. They are short and easily damaged.

7. Carefully separate the front and rear covers. See Figure 5-5.

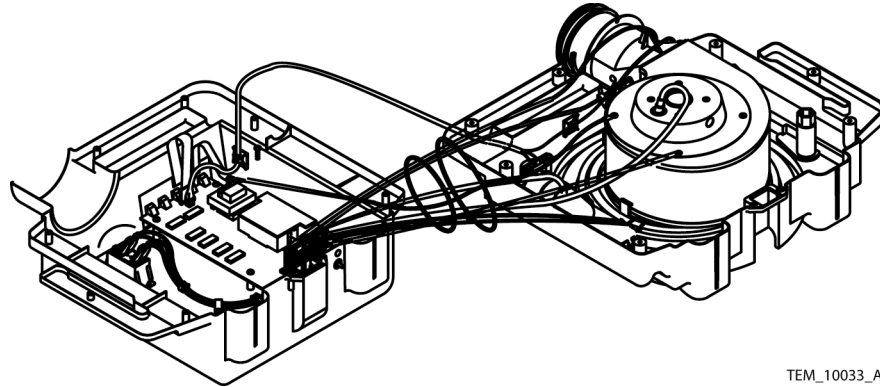

TEM_10033_A

Figure 5-5. Separated Covers

5.4 Rejoining the Front and Rear Covers

**Caution**

Ensure that the cable harness between the two covers is not pinched by the covers when joining them back together.

To rejoin the warming system covers:

1. Carefully align the covers and put them back together, placing the rear cover atop the front cover so that the covers nest.
2. Install the screws through the holes in the rear cover to attach it to the front cover. Tighten the screws to 7 to 10 in/lbs (18 cm/kg to 25 cm/kg). See Figure 5-6.

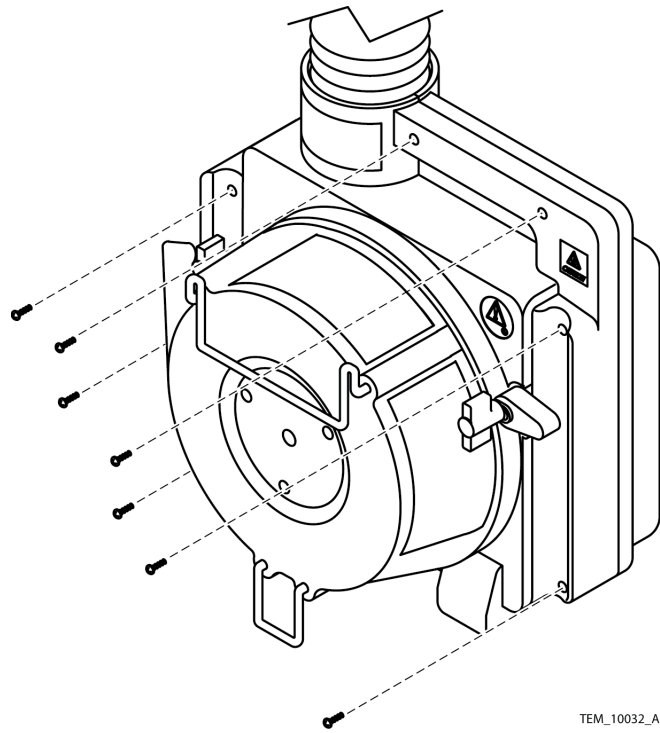

Figure 5-6. Cover Screw Locations

3. Connect the power cord connector to the warming system, making sure the connector is fully inserted into the socket in the warming system housing.
4. Reseat the power cord into the power cord routing bracket. If necessary, use the head of the flat blade screwdriver to separate the halves of the bracket sufficiently to allow reseating of the cord.

5.5 Front Cover Assembly Replacement

Table 5-4: Filter Cover Assembly Components

Qty	Component
1	Front enclosure
1	Key pad
1	Lens
1	Ground symbol label
1	Cable tie mount
1	Cable tie mount
1	Ground equipotential label
1	0.25 in (6.5 mm) hole for equipotential ground pin

Table 5-5: Tools Required for Replacing Front Cover Assembly

Tool	Parameters / Uses
Phillips screwdriver	#2
Torque driver/wrench	4 to 12 in/lbs (10 to 30 cm/kg)
	36 to 40 in/lbs (91 to 112 cm/kg)
Wire cutter	Cutting cable ties.
Socket wrench	10 mm
Flat blade screwdriver	Detaching power cord from filter cover.
Contact removal tool	AMP 305183 or equivalent

To replace the front cover assembly:

1. Separate the front and rear covers. See page 5-3, *Separating the Front and Rear Covers*.
2. Cut the cable harness bundle ties. See Figure 5-7

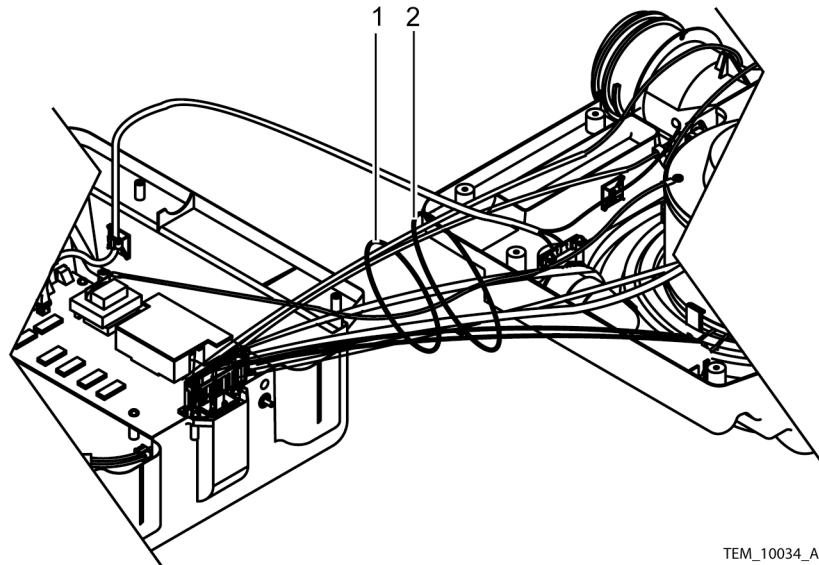

TEM_10034_A

Figure 5-7. Cable Harness Bundle Ties

3. Disconnect the 9-pin connector from the Control PCB (Figure 5-8, item 1).

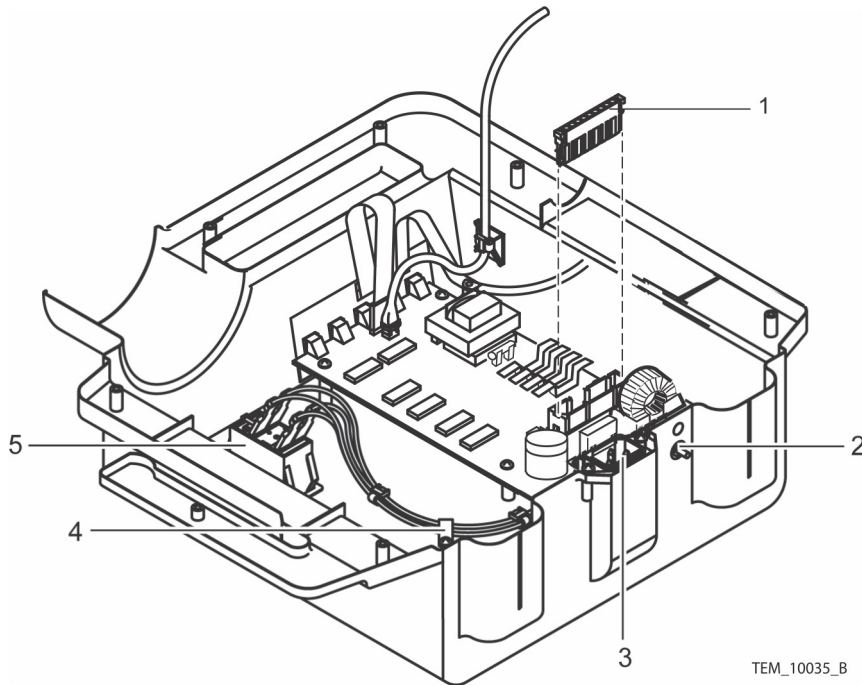

TEM_10035_B

- | | |
|---------------------------------|----------------|
| 1 9-Pin Connector | 4 Cable Clamp |
| 2 Equipotential Ground Terminal | 5 Power Switch |
| 3 AC Power Connector | |

Figure 5-8. Front Cover Assembly

4. Disconnect the equipotential ground stud and remove it from the front cover assembly (Figure 5-8, item 2).
5. Remove the AC power connector from the front cover assembly (Figure 5-8, item 3).
6. Remove the cable clamp from the front cover assembly (Figure 5-8, item 4).



Caution

Write down the color code of each wire connected to the power switch. This will ensure that the wires will be reconnected properly.

7. Disconnect the four wires from the power switch. See Figure 5-9.
8. Depress the four clips on the power switch and push the power switch through its hole in the front cover assembly. See Figure 5-9.

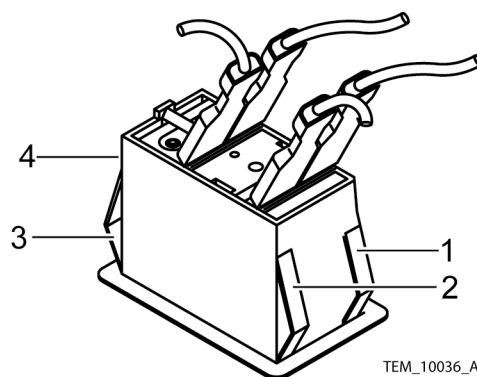

Figure 5-9. Power Switch Clips and Wires

9. Cut the cable tie (Figure 5-10, item 1).

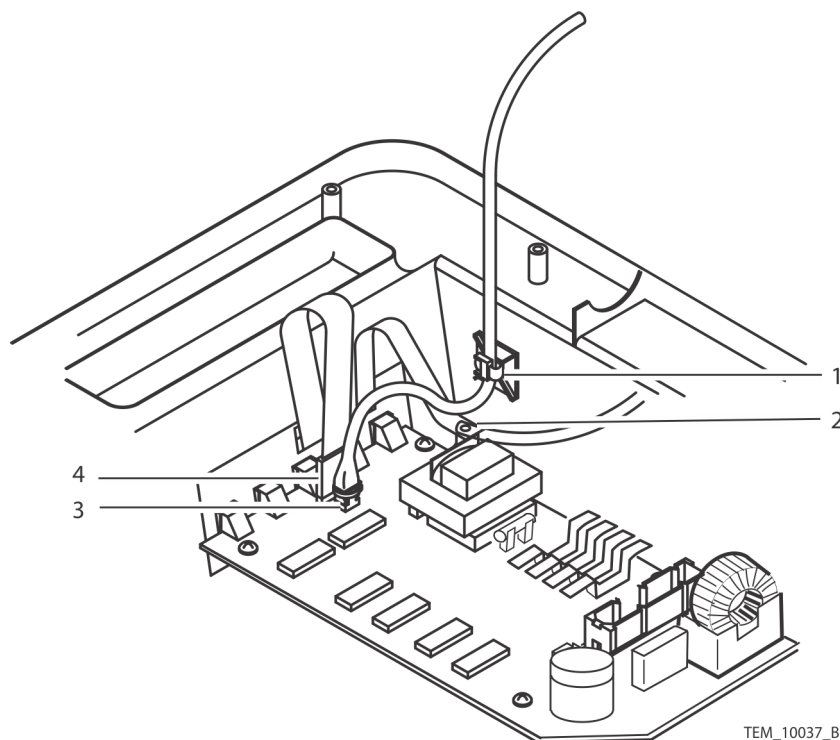

Figure 5-10. Cable Disconnect

10. Remove the ground screw (Figure 5-10, item 2).
11. Cut the cable tie holding the thermistor cable to the connector (Figure 5-10, item 3).
12. Disconnect the thermistor cable connector (Figure 5-10, item 3).
13. Disconnect the ribbon cable connector (Figure 5-10, item 4).
14. Remove the screws holding the Control PCB onto the front cover assembly

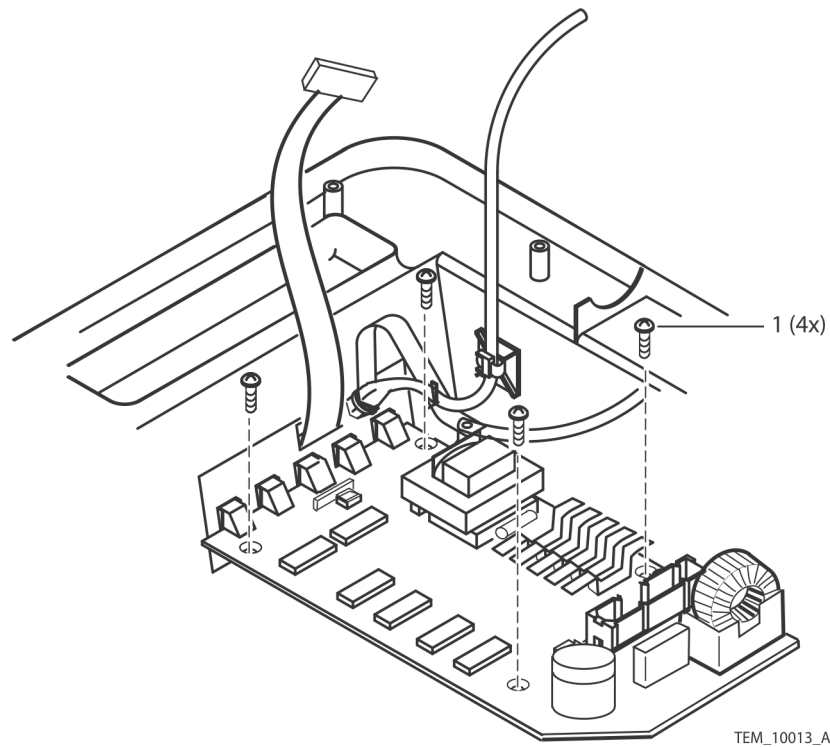

Figure 5-11. Control PCB Screws

15. Carefully lift the Control PCB out of the front cover assembly.
16. Discard the old front cover assembly.



Caution

Carefully align the lights on the Control PCB with the control panel key pad push buttons. Failure to do so could damage the key pad or the Control PCB lights. See Figure 5-10, items 1-5.

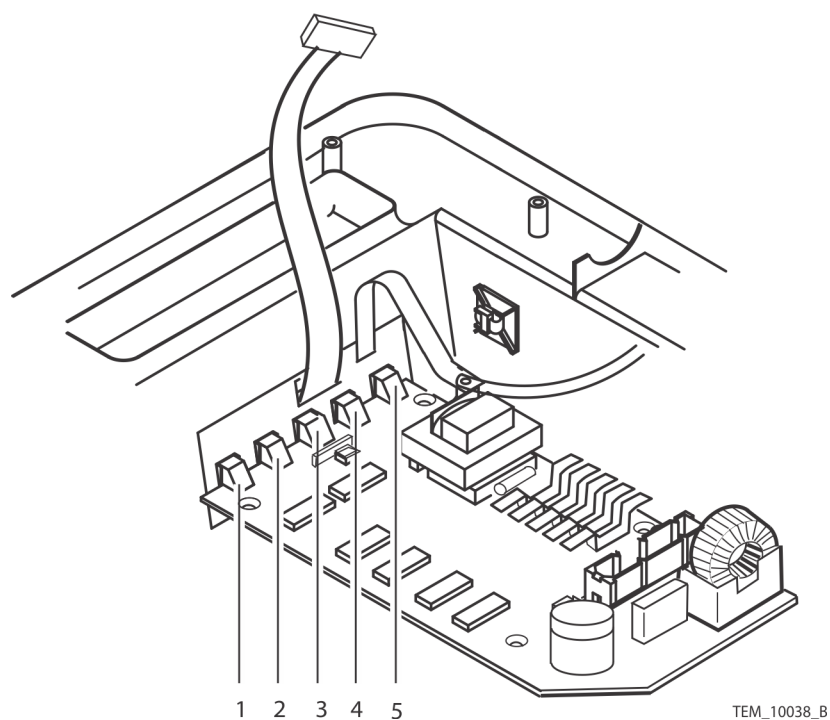

Figure 5-12. Control PCB Lights

17. Carefully place the Control PCB into the replacement front cover assembly and install the mounting screws. Tighten the screws to 4 to 6 in/lbs (10 to 15 cm/kg). See Figure 5-13.

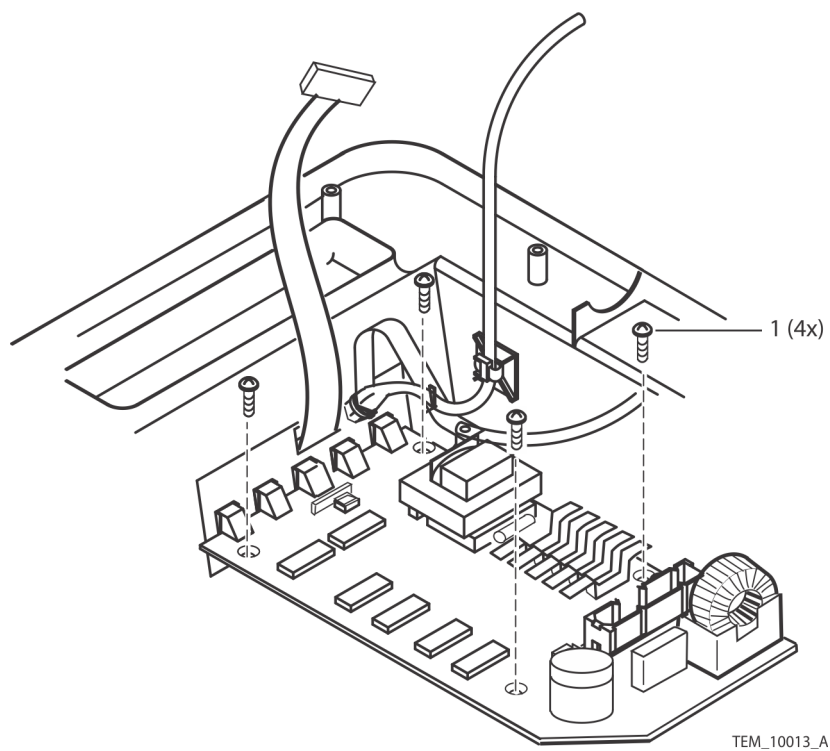

Figure 5-13. Control PCB Screws

18. Connect the ribbon cable connector (Figure 5-14, item 4).

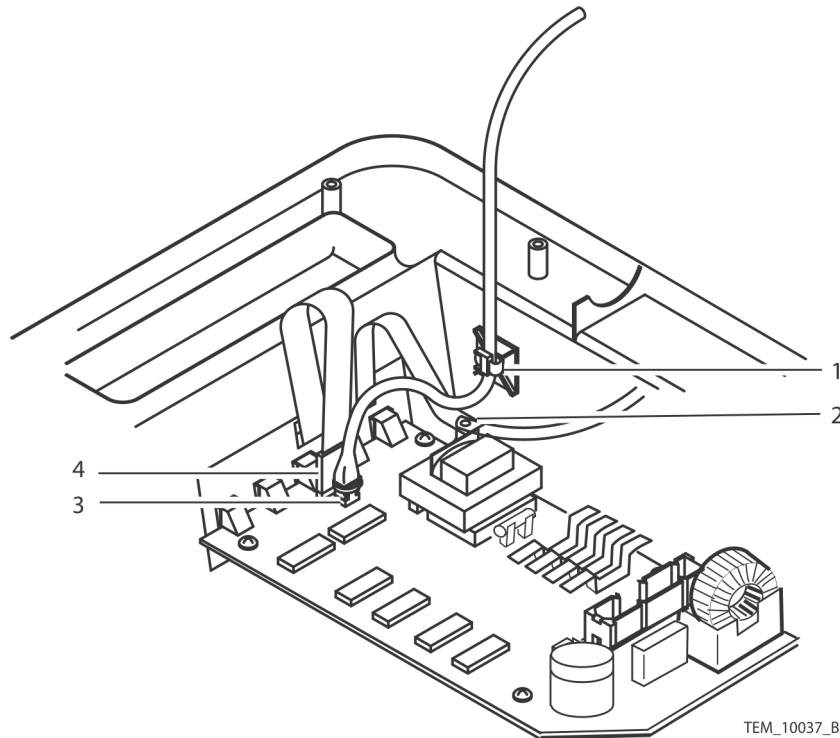

Figure 5-14. Cable Connections

19. Connect the thermistor cable connector (Figure 5-14, item 3).
20. Install the cable tie around the thermistor cable connector and Control PCB connector (Figure 5-14, item 2).
21. Connect the key pad grounding strap and blower ground wire. See Figure 5-14, item 2. Tighten the screw to 4 to 6 in/lbs (10 to 15 cm/kg).
22. Install the cable tie around the thermistor cable and the cable tie mount (Figure 5-14, item 1).
23. Slide the power switch through its hole in the front of the front cover assembly until the four clips on the power switch click into place. Ensure that the "0", marked on the front of the power switch, is towards the bottom of the front cover assembly. See Figure 5-15.

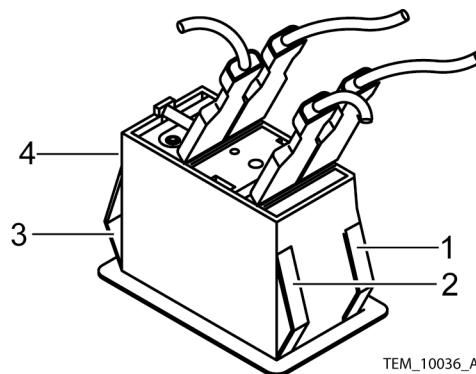

Figure 5-15. Power Switch Clips and Wires

24. Connect the four wires to the power switch. Make sure to reconnect the wires in the same way they were connected before; refer to the list of wire colors and where they were connected to the switch, as recorded in Step 7. See Figure 5-16, item 5.

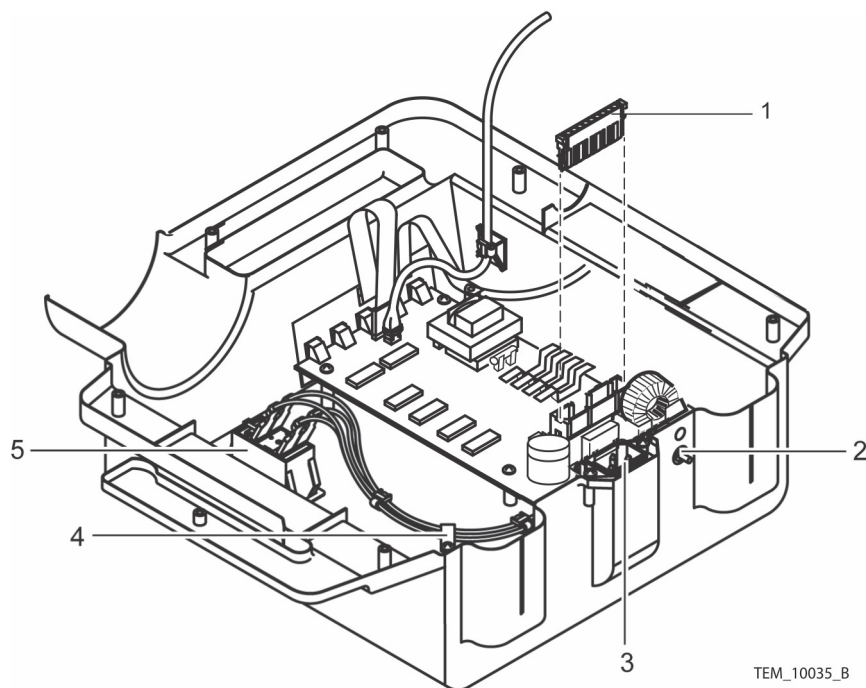
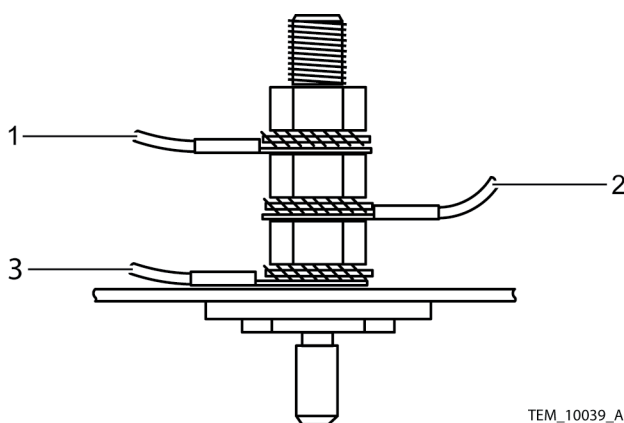

Figure 5-16. Front Cover Assembly Component Locations

25. Install the cable clamp around the power switch cables. Tighten the screw to 4 to 6 in/lbs (10 to 15 cm/kg). See Figure 5-16, item 4.
26. Install the AC power connector into the front cover assembly. Tighten the screws to 4 to 6 in/lbs (10 to 15 cm/kg). See Figure 5-16, item 3.
27. Install the equipotential ground (Figure 5-16, item 2) and attach ground wires as shown in Figure 5-17. Tighten nuts to 36 to 44 in/lbs (91 to 112 cm/kg).



- 1 Blower Housing Ground 3 Blower Motor Ground**
2 Blower Motor Ground

Figure 5-17. Equipotential Ground Stud Wiring

28. Connect the 9-pin connector to the Control PCB. See Figure 5-16, item 1.
29. Install the cable harness bundle ties. See Figure 5-18.

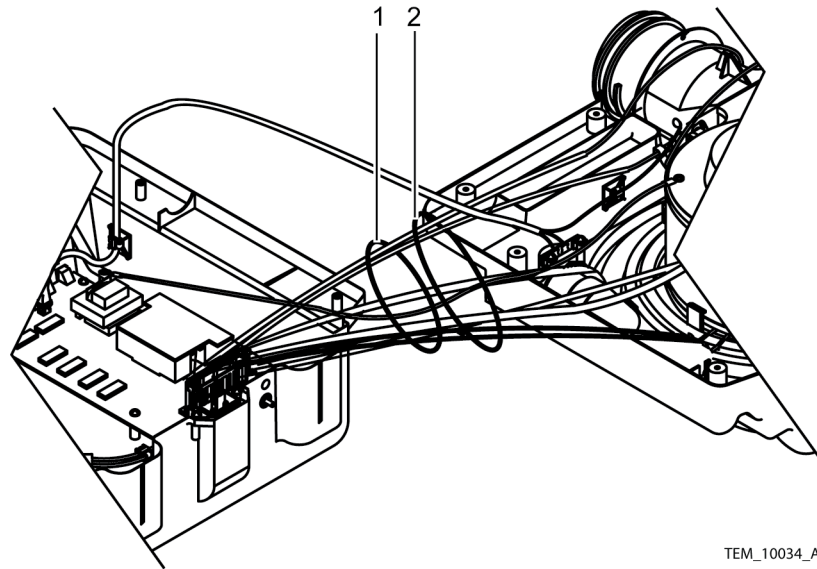

Figure 5-18. Cable Harness Bundle Ties

30. Rejoin the front and rear covers. See page 5-5, *Rejoining the Front and Rear Covers*.
31. Perform the following checks/tests to verify proper operation of the warming system prior to returning it into service:
 - a. *Power Fail / Start Alarm Check* on page 4-1
 - b. *Thermostat Protection Check* on page 4-2
 - c. *Output Temperature Check* on page 4-4
 - d. *Safety Tests* on page 4-6

5.6 Control PCBA Replacement

The replacement Control PCB (P/N GR100306) comes fully assembled.

Table 5-6: Tools Required for Replacing Control PCB

Tool	Parameter / Use
Phillips screwdriver	#2 / Removing screws.
Torque driver	4 to 20 in/lbs (10 to 51 cm/kg)
Wire cutter	Cutting cable ties and jumpers.
Flat blade screwdriver	Detaching power cord from filter cover.

To replace the Control PCB assembly:

1. Separate the front and rear covers. See page 5-3, *Separating the Front and Rear Covers*.
2. Disconnect the 9-pin connector from the Control PCB (Figure 5-19, item 1).

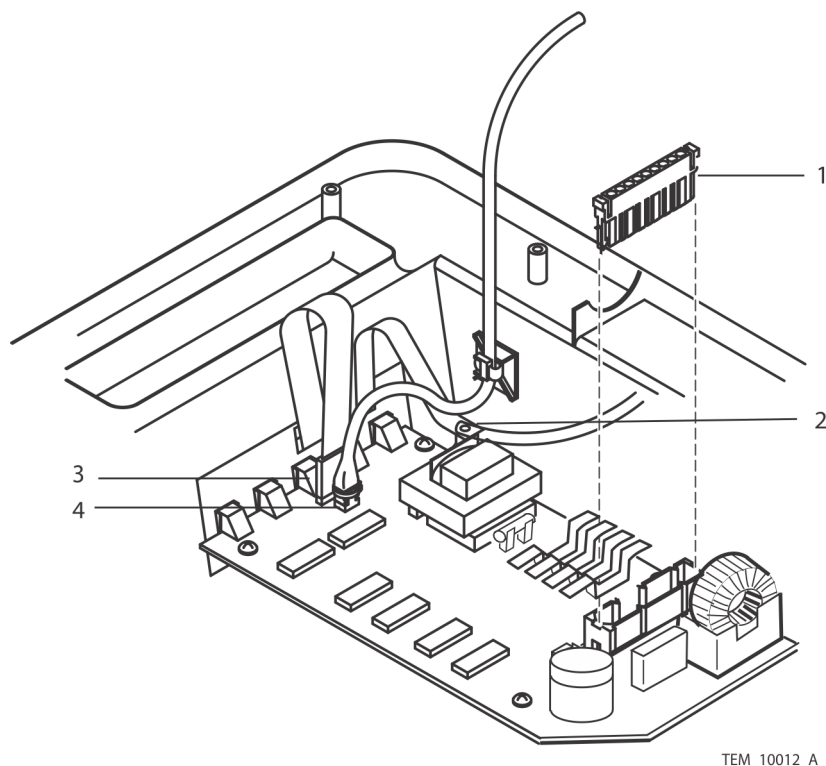

- | | | | |
|---|--------------------------|---|-------------------------------|
| 1 | 9-pin Connector | 3 | Keypad Ribbon Cable Connector |
| 2 | Keypad and Blower Ground | 4 | Thermistor Cable Connector |

Figure 5-19. Control PCB Connections

3. Remove the thermistor cable connector cable tie.
4. Disconnect the thermistor cable connector (Figure 5-19, item 4).
5. Disconnect the ribbon cable connector (Figure 5-19, item 3).
6. Remove the screws holding the Control PCB onto the front cover assembly.
7. Carefully lift the Control PCB out of the front cover assembly.



Caution

Carefully align the lights on the Control PCB with the control panel key pad push buttons. Failure to do so could damage the key pad or the Control PCB lights. See Figure 5-20, items 1-5.

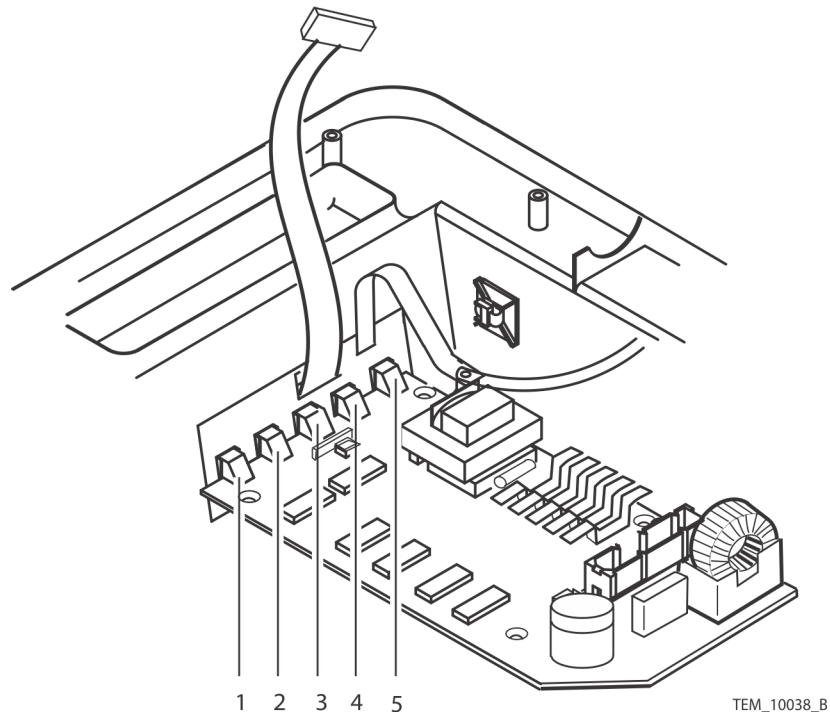

Figure 5-20. Control PCB Lights

8. Carefully place the replacement Control PCB into the front cover assembly and install the mounting screws. Tighten the screws to 4 to 6 in/lbs (10 to 15 cm/kg). See Figure 5-21.

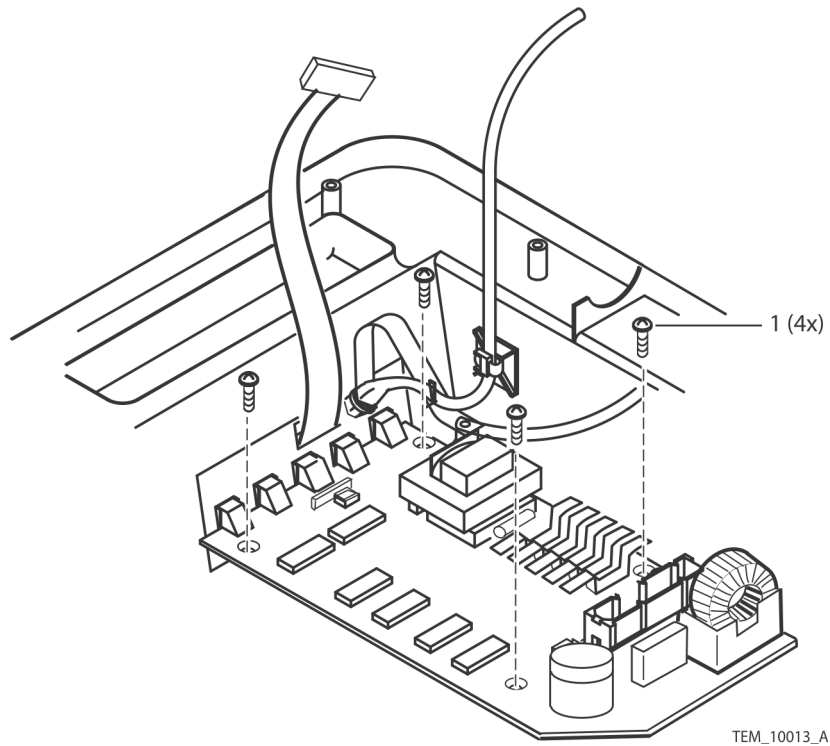

Figure 5-21. Control PCB Screws

9. Connect the ribbon cable connector (Figure 5-22, item 3).

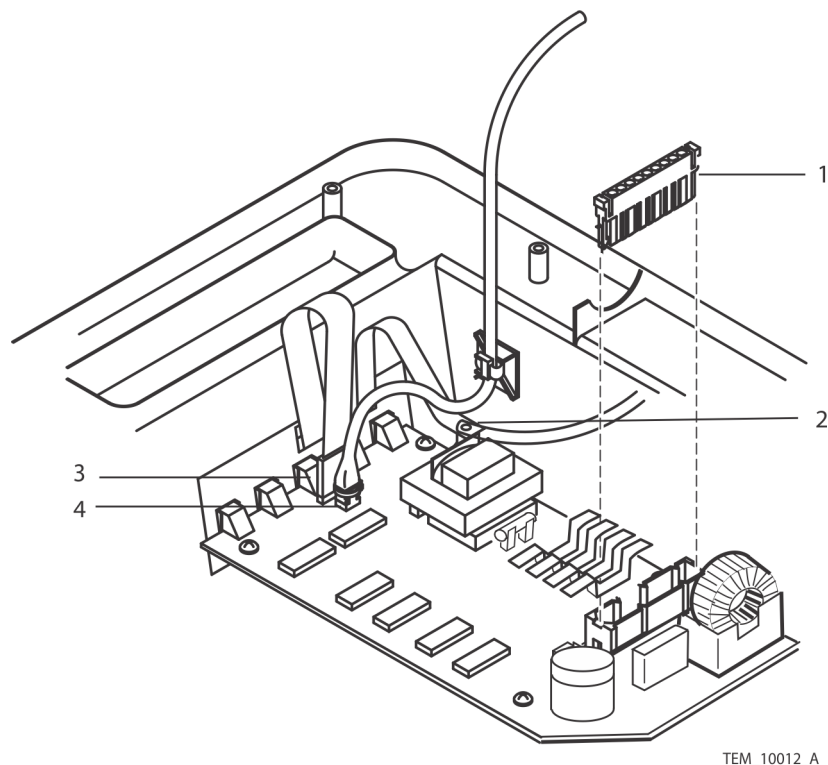

Figure 5-22. Cable Connections

10. Connect the thermistor cable connector (Figure 5-22, item 4)
11. Attach a cable tie around the thermistor cable connector and the Control PCB connector.
12. Connect the 9-pin connector to the Control PCB (Figure 5-22, item 1).
13. Install the cable harness bundle ties. See Figure 5-23, item 1.

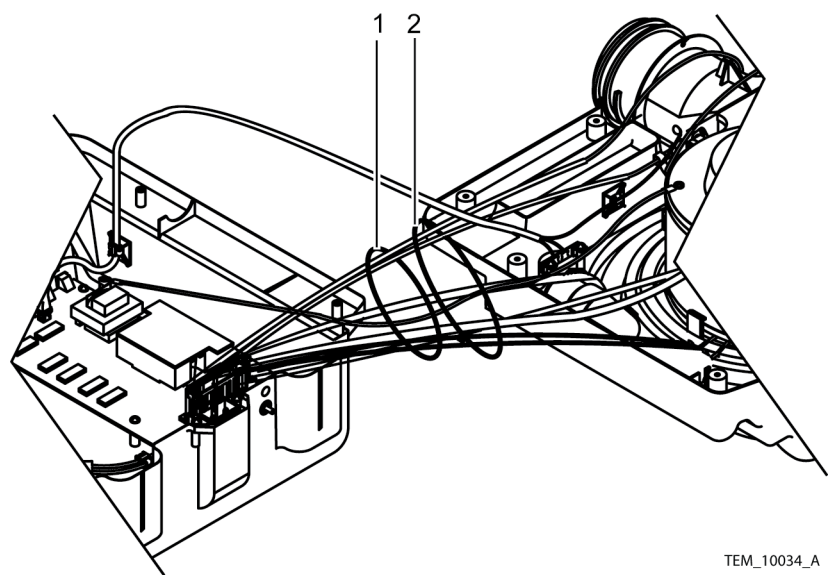

Figure 5-23. Cable Harness Ties

14. Rejoin the front and rear covers. See page 5-5, *Rejoining the Front and Rear Covers*.
15. Perform the following checks/tests to verify proper operation of the warming system prior to returning it into service:
 - a. *Power Fail / Start Alarm Check* on page 4-1
 - b. *Thermostat Protection Check* on page 4-2
 - c. *Output Temperature Check* on page 4-4
 - d. *Safety Tests* on page 4-6

5.7 Heater Assembly Replacement

Table 5-7: Heater Assembly Components

Qty	Component
1	Heater, 230V
2	Pins, 16-18 GA, 13 A

Table 5-8: Tools Required for Replacing Heater Assembly

Tool	Parameter / Use
Phillips screwdriver	#2 / Removing screws
Wire cutter	Cutting cable ties
Socket	10 mm
Contact removal tool	AMP 305783 or equivalent
Torque driver/wrench	4 to 12 in/lbs (10 to 30 cm/kg)
	36 to 44 in/lbs (91 to 112 cm/kg)
Flat blade screwdriver	Detaching power cord from filter cover

To replace the heater assembly:

1. Remove the filter cover assembly from the rear cover assembly. See page 5-2, *Filter Cover Assembly Replacement*.
2. Remove the filter assembly from the rear cover assembly. See Figure 5-24, item 1.



Figure 5-24. Filter Removal



NOTE:

The blower assembly is attached to the rear cover assembly by four screws and four clips. It is easier for two people to release the clips and lift the blower assembly from the rear cover assembly.

3. Remove the four screws holding the blower assembly to the rear cover assembly. See Figure 5-25.

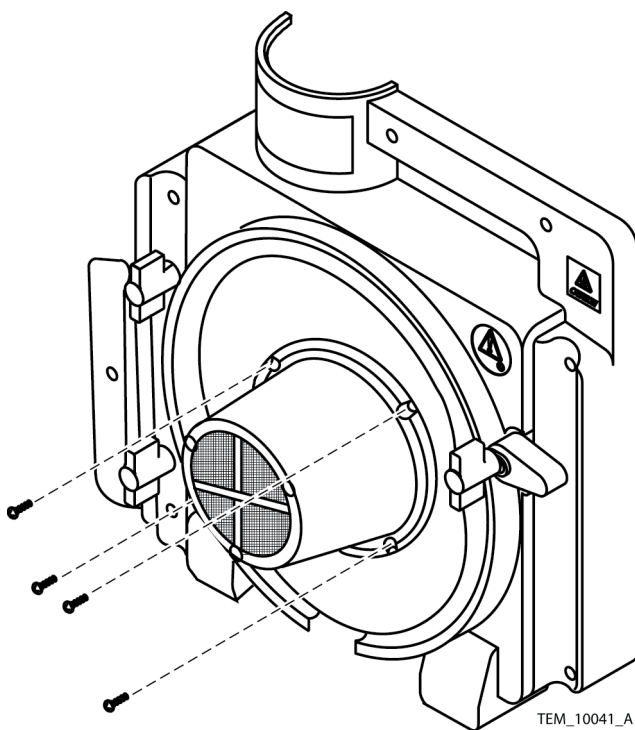

Figure 5-25. Blower Assembly Screws

4. Separate the front and rear covers. See page 5-3, *Separating the Front and Rear Covers*.
5. Cut the cable harness bundle ties. See Figure 5-26, items 1 and 2.

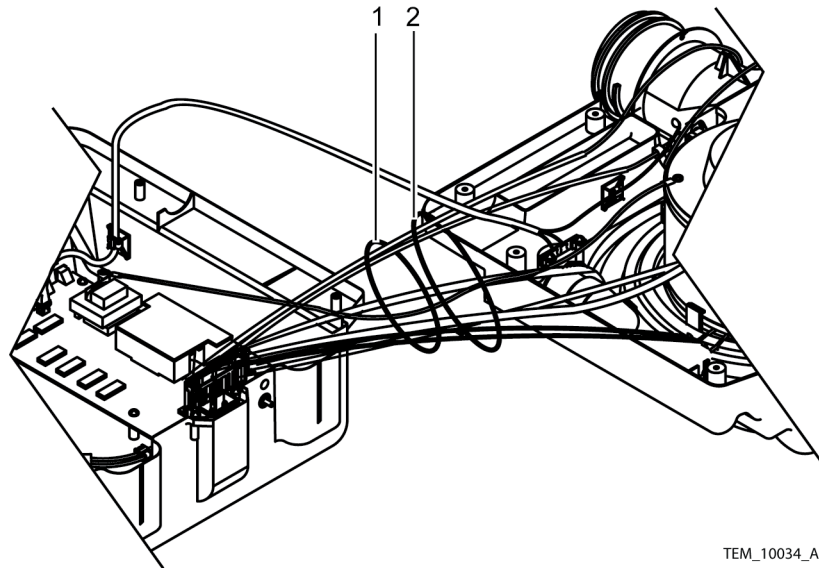

Figure 5-26. Cable Harness Bundle Ties

6. Disconnect the 9-pin connector from the Control PCB. See Figure 5-27, item 1.



NOTE:

During the remainder of this procedure, make sure not to apply excessive pressure to the wires still connected between the separated halves of the warming system.

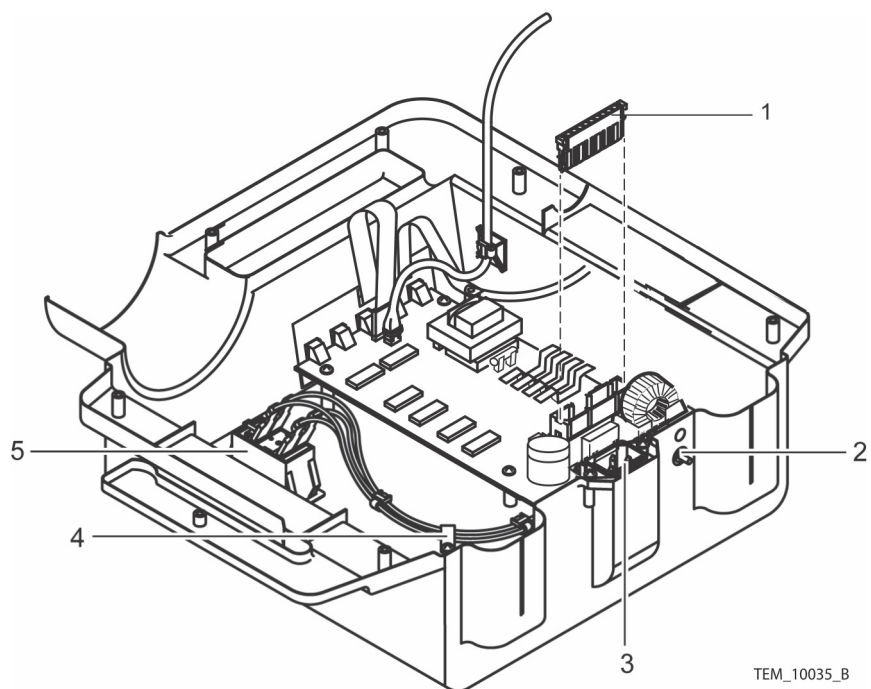

- | | | | |
|---|-------------------------------|---|--------------|
| 1 | 9-Pin Connector | 4 | Cable Clamp |
| 2 | Equipotential Ground Terminal | 5 | Power Switch |
| 3 | AC Power Connector | | |

Figure 5-27. Front Cover Assembly



Caution

Care must be taken when moving the duct adapter. The thermistor connection to the duct adaptor is fragile and will become disconnected if too much pressure is applied to it.

7. Carefully lift the duct adapter and lay the duct adapter on the rear cover handle. See Figure 5-28.

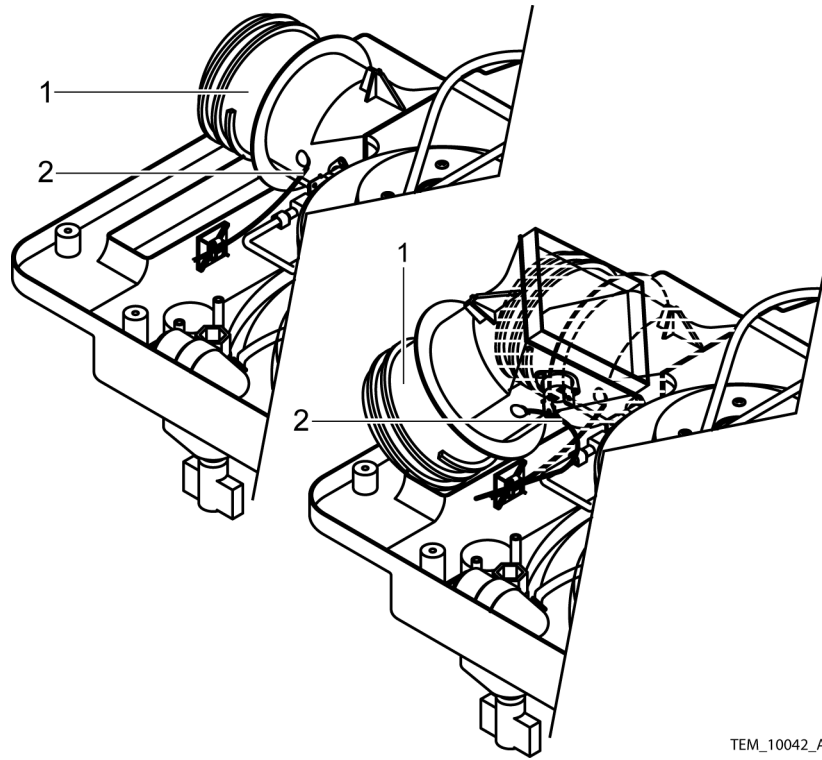

TEM_10042_A

1 Duct Adapter

2 Thermistor Connection

Figure 5-28. Duct Adapter Placement

8. Rotate the blower motor assembly clockwise to disengage two of the four clips. See Figure 5-29 and Figure 5-30.

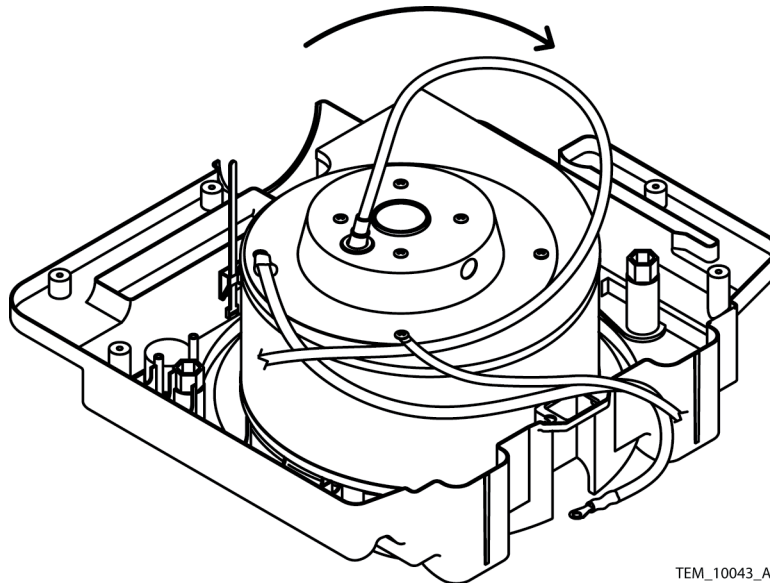

TEM_10043_A

Figure 5-29. Blower Motor Removal

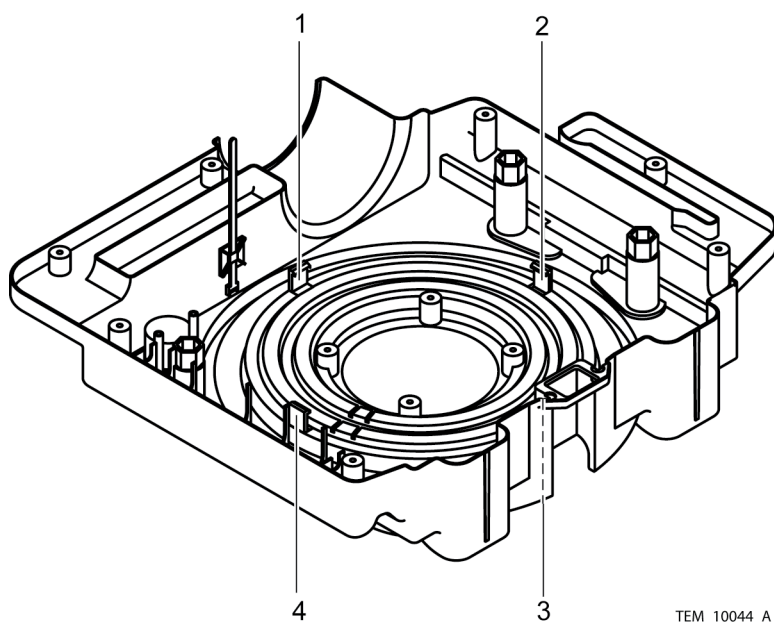

Figure 5-30. Blower Assembly Clips

9. Slide the blower motor assembly away from the engaged clips to disengage them.
10. Lay the blower motor assembly beside the rear cover assembly. Do not overstress the connecting wires.
11. Remove the rubber gasket from the rear cover assembly.

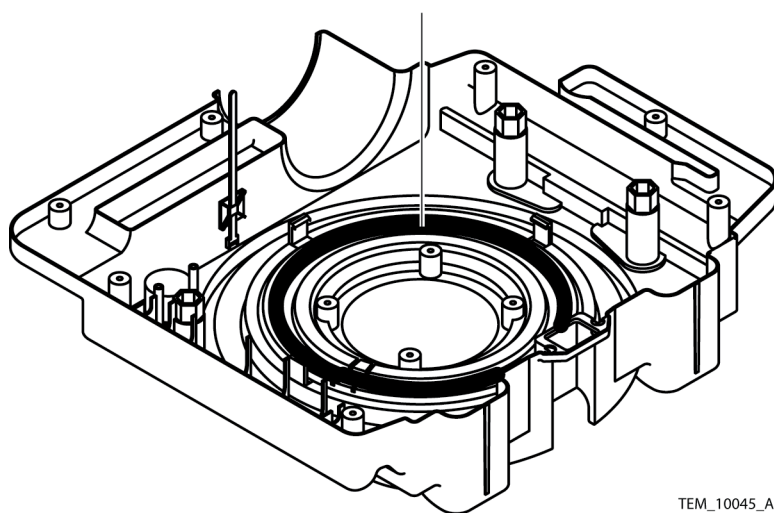

Figure 5-31. Rubber Gasket



Caution

Do not touch the heater coil. Body oil can damage the heater coil when it is in use.

12. Lift the heater assembly (Figure 5-32, item 1) out of the rear cover assembly.

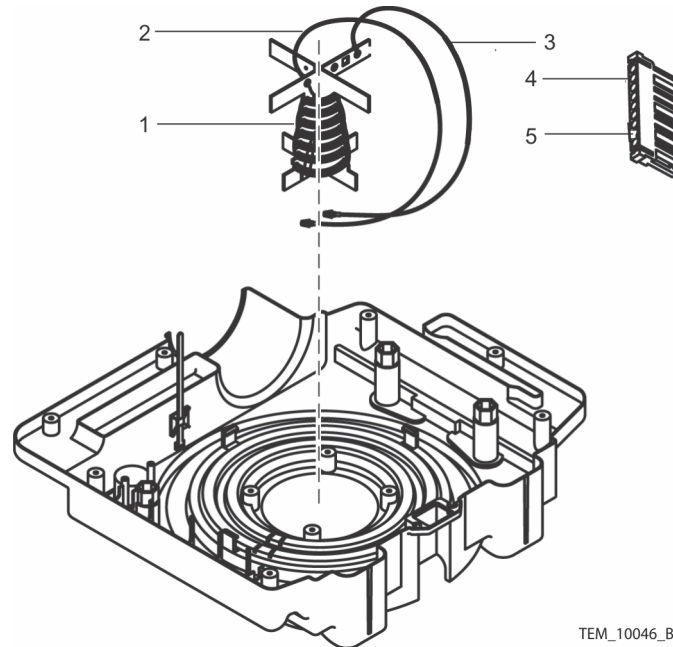

Figure 5-32. Heater Assembly



NOTE:

For the next four steps, use an AMP 305183 contact removal tool or equivalent.

13. Remove the black wire and pin (Figure 5-32, item 3) from pin 2 of the 9-pin connector (Figure 5-32, item 5).
14. Remove the red wire (may be white in some assemblies) and pin (Figure 46, item 2) from pin 8 of the 9-pin connector (Figure 5-32, item 4).
15. Install the red wire and pin from the new heater into pin 8 of the 9-pin connector.
16. Install the black wire and pin from the new heater into pin 2 of the 9-pin connector.



NOTE:

Ensure that the heater thermostat (Figure 5-33, item 3) is oriented upward when reinstalling the heater in the rear cover assembly.

17. Slide the new heater into the rear cover assembly. See Figure 5-33.

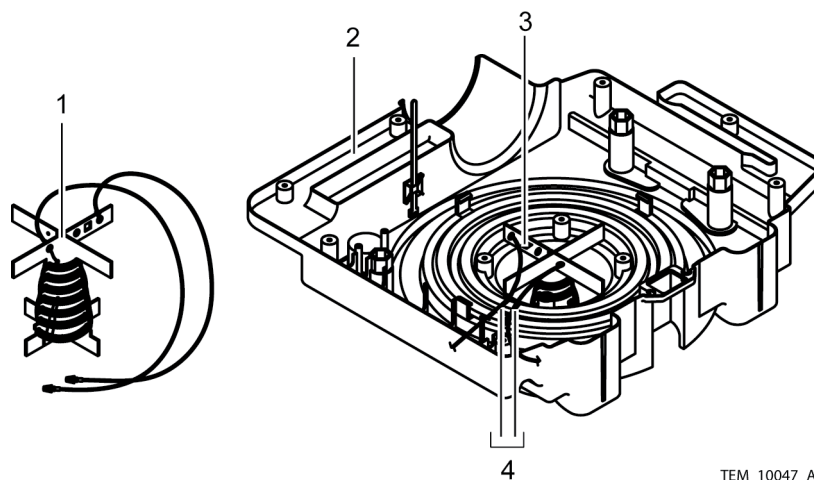

TEM_10047_A

- | | | | |
|---|---------------------------|---|----------------------------|
| 1 | Heater Assembly (removed) | 3 | Heater Assembly (in place) |
| 2 | Rear Panel Assembly | 4 | Heater Wire Cutouts |

Figure 5-33. Heater Assembly Installation

18. Orient the heater so that the heater thermostat (Figure 5-33, item 3) is nearest the rear cover assembly handle (Figure 5-33, item 2).
19. Route the black and red wires from the heater through the cut-outs in the rear cover assembly (Figure 5-33, item 4).
20. Place the rubber gasket into the rear cover assembly, with the wire indentations over the heater wires. See Figure 5-34, item 1.

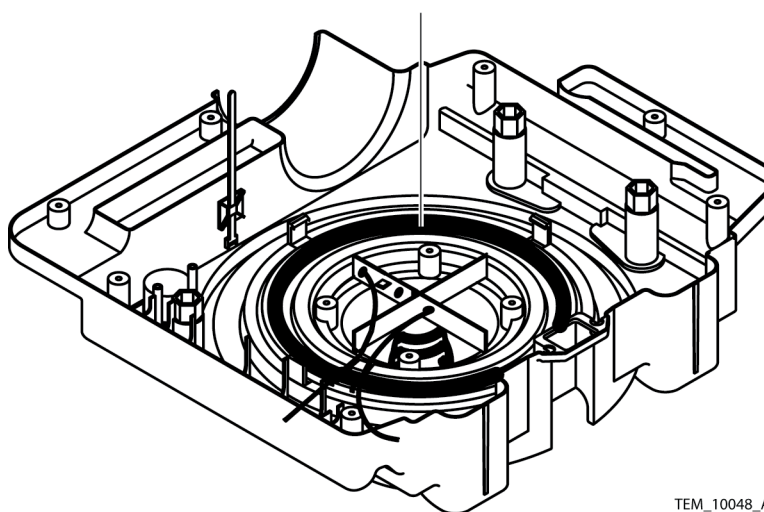

TEM_10048_A

Figure 5-34. Rubber Gasket

21. Place the blower assembly into the rear cover assembly and ensure that the blower assembly clips (shown in Figure 5-35) attach over the edges of the blower assembly.

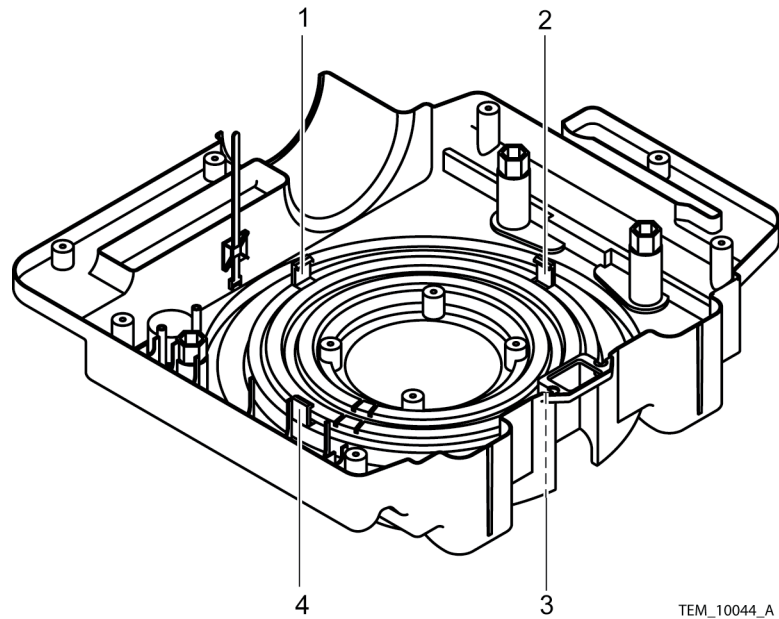

Figure 5-35. Blower Assembly Clips



Caution

Exercise caution when moving the duct adapter. Do not apply excessive pressure, as the thermistor connection to the duct adaptor is fragile and can easily become disconnected.

22. Carefully reinsert the duct adapter into the blower assembly. See Figure 5-36.

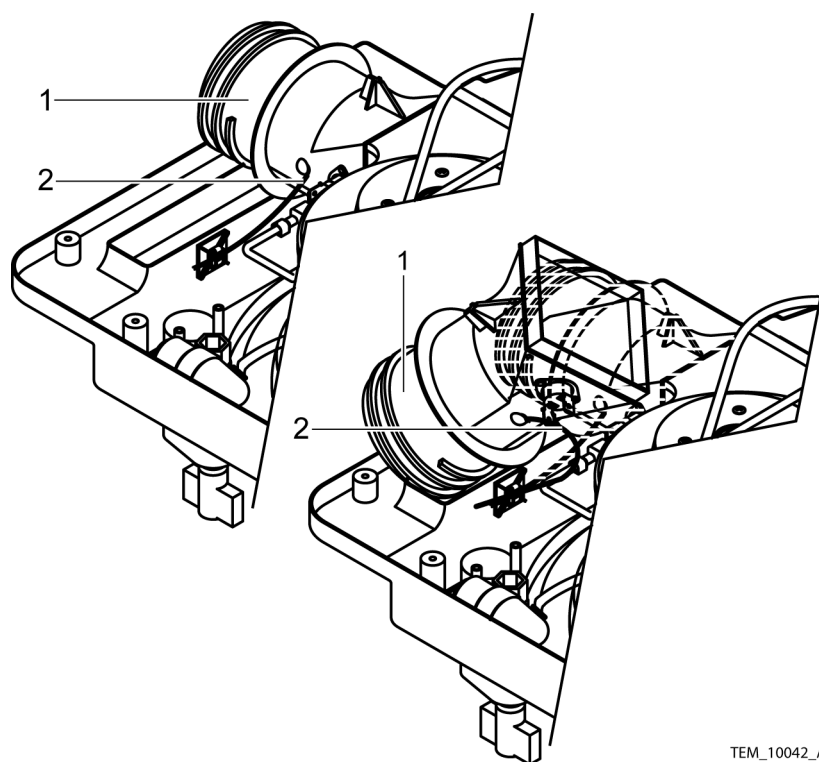

TEM_10042_A

1 Duct Adapter

2 Thermistor Connection

Figure 5-36. Duct Adapter Placement

**NOTE:**

If the rivet holding the thermistor in place in the duct is loose or pulled out entirely, follow the instructions in the *Duct Adapter Assembly Replacement* section (page 5-31) to reseat the thermistor.

23. Install the blower assembly mounting screws into the rear cover assembly. Tighten the screws to 4 to 6 in/lbs (10 to 15 cm/kg).

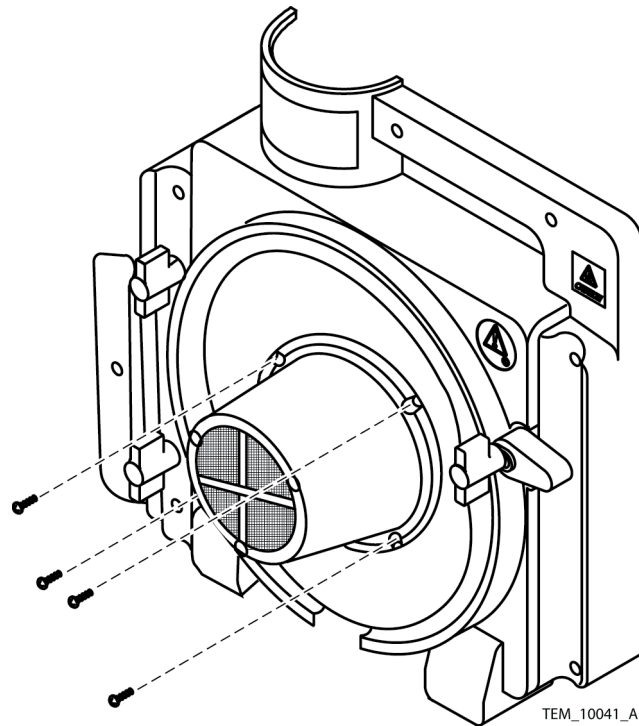

Figure 5-37. Blower Assembly Screws

24. Connect the 9-pin connector to the Control PCB. See Figure 5-27, item 1.
25. Install the cable harness bundle ties. See Figure 5-38, items 1 and 2.

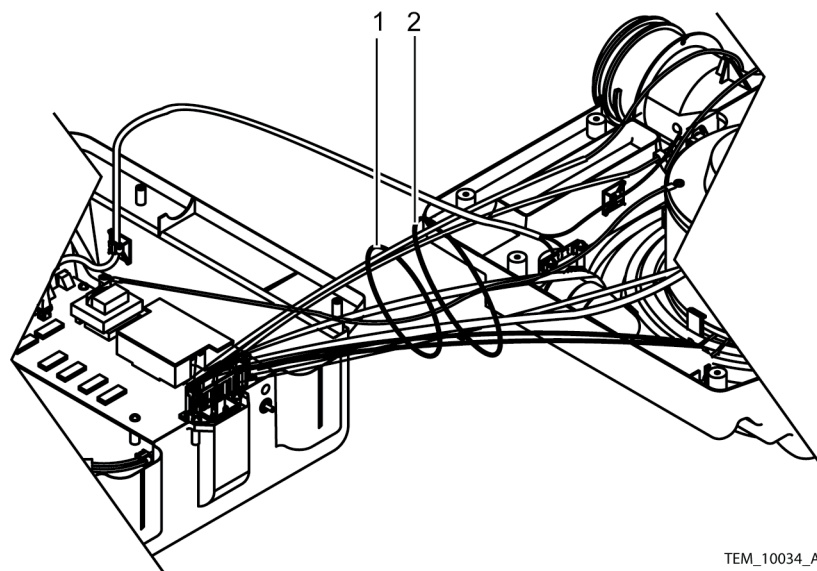

Figure 5-38. Cable Harness Bundle Ties

26. Rejoin the front and rear covers. See page 5-5, *Rejoining the Front and Rear Covers*, steps 1 and 2.
27. Place the filter assembly into the rear cover assembly.



Figure 5-39. Filter Installation

28. Install the filter cover assembly on the rear cover assembly. Tighten the screws to 8 to 12 in/lbs (20 to 30 cm/kg). See Figure 5-40.

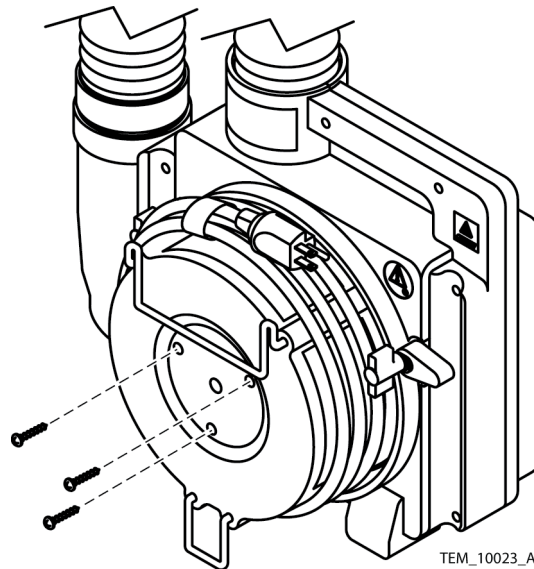

Figure 5-40. Filter Cover Installation

29. Install the power cord on the warming system, inserting the female connector into its socket on the warming system housing, and seating the cord in the routing bracket on the filter cover. If necessary, use the head of a flat blade screwdriver to separate the halves of the routing bracket sufficiently to allow seating of the cord.
30. Perform the following checks/tests to verify proper operation of the warming system prior to returning it into service:
- a. *Power Fail / Start Alarm Check* on page 4-1
 - b. *Thermostat Protection Check* on page 4-2
 - c. *Output Temperature Check* on page 4-4
 - d. *Safety Tests* on page 4-6

5.8 Hose Replacement

Table 5-9: Hose Assembly Components

Qty	Component
1	Hose
1	Nozzle Strap with Clip

Table 5-10: Tools Required for Replacing Hose Assembly

Tool	Parameter / Use
Wire cutter	Cutting reinforcing wire
Pliers	Bending reinforcing wire



NOTE:

If the warming system hose is damaged, contact your local Covidien representative to obtain a replacement hose. The hose for the warming system is made of plastic reinforced with wire.



Caution

Only qualified service technicians should replace the hose.

To replace the hose:

1. Separate the front and rear covers. See page 5-3, *Separating the Front and Rear Covers*.
2. Locate the end of the hose on the duct adapter
3. Find the end of the hose's reinforcing wire that is inserted into the locking hole in the duct adapter. Pull the end of the wire out of the locking hole.
4. Turn the hose counterclockwise to unscrew it from the duct adapter.
5. On the replacement hose, find the end of the reinforcing wire that is free of the hose material and trim the wire so that approximately 5/8" remains free.
6. At a point 1/2" from its free end, bend the wire 90 degrees inward (perpendicular to the hose).
7. Put the end of the replacement hose onto the duct adapter
8. Turn the hose clockwise to screw it onto the duct adapter, until the bent end of the reinforcing wire is aligned with the locking hole.
9. Push the end of the wire into the locking hole to secure the hose in place.
10. Remove the nozzle from the end of the old hose and install it onto the free end of the replacement hose. Refer to page 25, *Nozzle Replacement*.
11. Remove the blanket clip from the old hose and slide it over the nozzle onto the replacement hose.
12. Rejoin the front and rear covers. See page 5-5, *Rejoining the Front and Rear Covers*.

13. Perform the following checks/tests to verify proper operation of the warming system prior to returning it into service:
- *Power Fail / Start Alarm Check* on page 4-1
 - *Thermostat Protection Check* on page 4-2
 - *Output Temperature Check* on page 4-4
 - *Safety Tests* on page 4-6

5.9 Duct Adapter Assembly Replacement

Table 5-11: Duct Adapter Assembly Components

Qty	Component
1	Duct Adapter
2	Screen

Table 5-12: Tools Required for Replacing Duct Adapter Assembly

Tool	Parameter / Use
Phillips screwdriver	#2 / Removing screws
Wire cutter	Cutting cable ties
Knife	Removal of silicone RTV
Silicone RTV	Thermistor connection
Torque driver/wrench	7 to 12 in/lbs (18 to 30 cm/kg)
Flat blade screwdriver	Detaching power cord from filter cover Removing thermostat rivets
Needlenose pliers	Removing thermostat rivets

To replace the duct adapter assembly:

1. Separate the front and rear covers. See page 5-3, *Separating the Front and Rear Covers*.



Caution

The thermistor is very delicate and easily damaged. Use extreme care when handling, removing, or replacing the thermistor.

2. Remove the silicone RTV from the thermistor connection on the duct adapter assembly. See Figure 5-41, item 1.

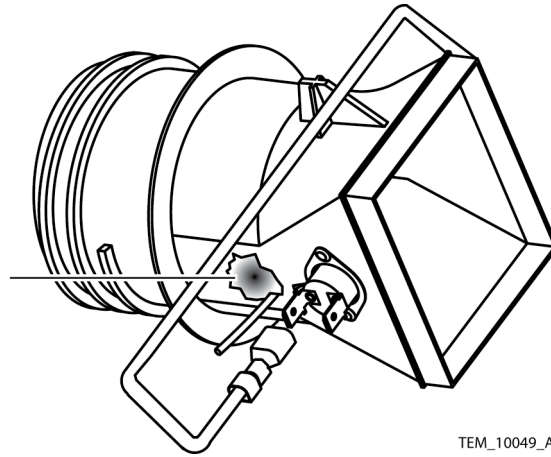

TEM_10049_A

Figure 5-41. Thermistor Silicone

3. Carefully slide the thermistor out of the duct adapter assembly. See Figure 5-42, item 2.

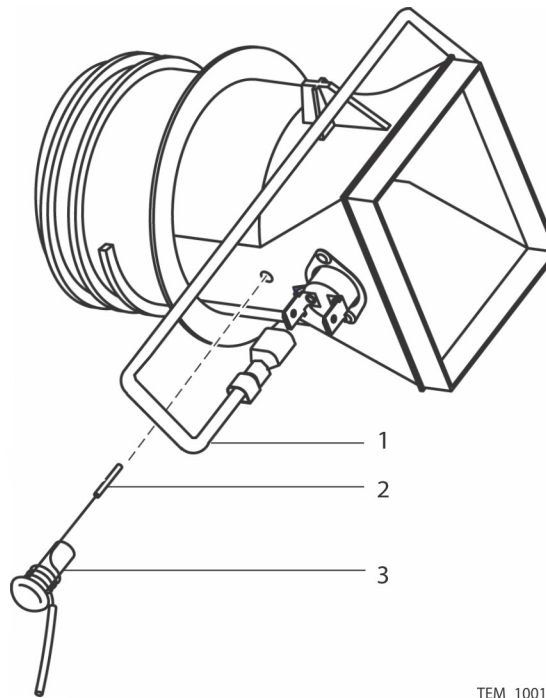

TEM_10015_A

Figure 5-42. Thermistor Removal

4. Detach the wires from the two thermostats on the side of the duct transition. Leave the jumper wire connecting the two thermostats in place.
5. Lift the duct adapter assembly out of the rear cover assembly. See Figure 5-43, item 1.

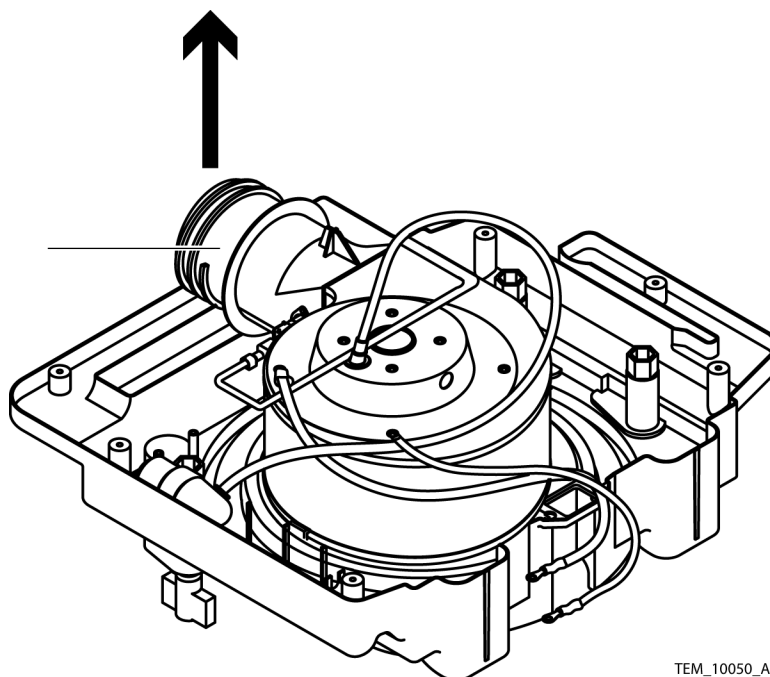
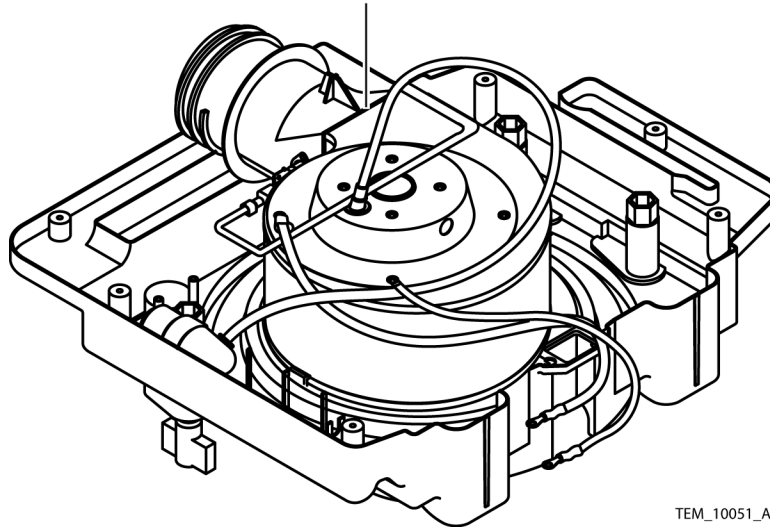

Figure 5-43. Duct Adapter Removal

6. Using the flat blade screwdriver, reach inside the duct and push the locking pin on each of the plastic rivets holding the thermostats in place downward, so that the pins are flush with the surface of the rivet.
7. Outside the duct, use the needlenose pliers to pull each locking pin upward (out from the duct) until the rivet is loose and pulls free from the duct. **Save the rivets and their locking pins.**
8. Line up the holes in the thermostat mounting flanges with the holes in the replacement duct.
9. Reinstall the plastic rivets, pushing them through the holes in the thermostat mounting flanges into the holes in the replacement duct. Outside the duct, use the flat blade screwdriver to push the locking pins on the rivets inward so that they are flush with the tops of the rivets.
10. Connect the two wires previously attached to the old duct adapter onto the replacement duct adapter, connecting them to the same connection points.
11. Slide the new duct adapter assembly into the blower housing.



TEM_10051_A

Figure 5-44. Duct Adapter Placement**Caution**

The thermistor is very delicate and easily damaged. Use extreme care when handling, removing or replacing the thermistor.

12. Carefully reinsert the thermistor into the duct adapter assembly. See Figure , item 1.

**NOTE:**

Position the thermistor as shown.

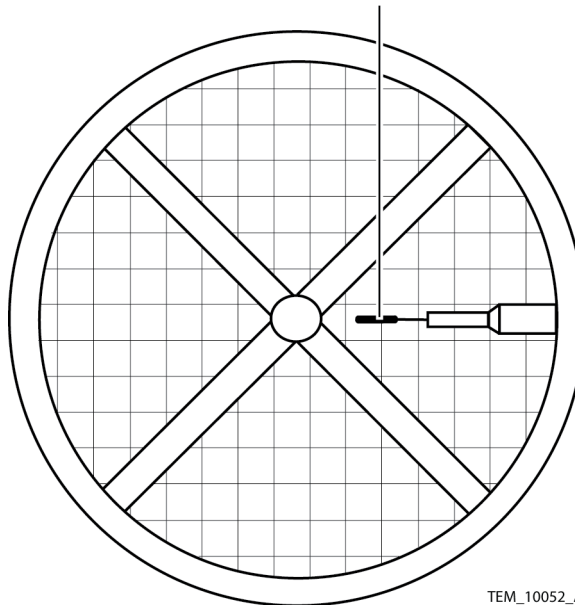

TEM_10052_A

Figure 5-45. Thermistor Position Within Duct Adapter

13. Apply a small amount of silicone RTV to the thermistor rivet cap and the adapter housing. See Figure 5-41.
14. Rejoin the front and rear covers. See page 5-5, *Rejoining the Front and Rear Covers*.
15. Perform the following checks/tests to verify proper operation of the warming system prior to returning it into service:
 - a. *Power Fail / Start Alarm Check* on page 4-1
 - b. *Thermostat Protection Check* on page 4-2
 - c. *Output Temperature Check* on page 4-4
 - d. *Safety Tests* on page 4-6

5.10 Rear Cover Assembly Replacement

Table 5-13: Rear Cover Assembly Components

Qty	Component
1	Rear Enclosure
1	Cable Clamp
1	Cable Tie
3	Lag Bolts, 3¼
1	Test Cover
1	Screw
1	Heater Cone Insert
1	Heater Screen
1	Attention Label

Table 5-14: Tools Required for Replacing Rear Cover Assembly

Tool	Parameter / Use
Phillips screwdriver	#2 / Removing screws
Wire cutter	Cutting cable ties
Socket	10 mm
Torque driver/wrench	4 to 12 in/lbs (10 to 30 cm/kg)
	36 to 44 in/lbs (91 to 112 cm/kg)
Flat blade screwdriver	Detaching power cord from filter cover

To replace the rear cover assembly:

1. Unplug the warming system power cord from the AC outlet.
2. Lay the warming system on its front side so that the bottom of the unit is visible.
3. Remove the filter cover screws from the warming system. See Figure 5-46.

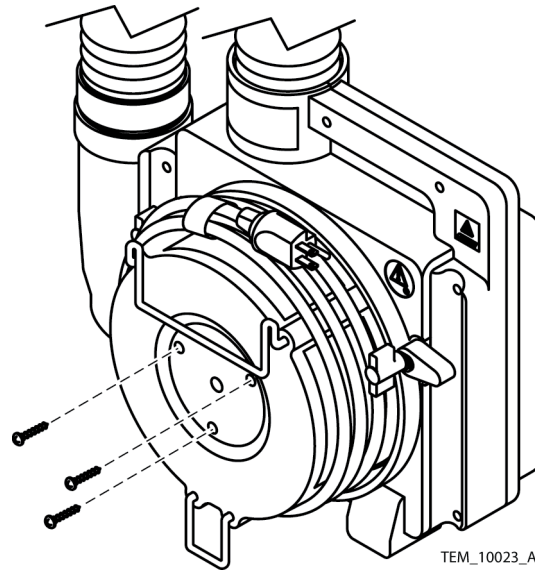
**Figure 5-46. Filter Cover Screws**

4. Unseat the power cord from the power cord routing bracket on the filter cover. If necessary, use the head of the flat blade screwdriver to separate the halves of the bracket sufficiently to allow unseating of the cord.
5. Disconnect the power cord connector from the warming system.
6. Remove the filter cover assembly from the warming system.
7. Remove the filter assembly from the rear cover assembly. See Figure 5-57, item 1.

**Figure 5-47. Filter Removal**

8. Separate the front and rear covers. See page 5-3, *Separating the Front and Rear Covers*.

**Caution**

Separate the front and rear covers very carefully. Do not apply too much pressure to the wires connecting the covers. They are short and easily damaged.

**NOTE:**

Perform steps 9 through 18 if complete separation of the front and rear halves of the unit is desired or necessary. Otherwise, skip to step 19.

9. Cut the two cable bundle ties. See Figure 5-48, items 1 and 2.

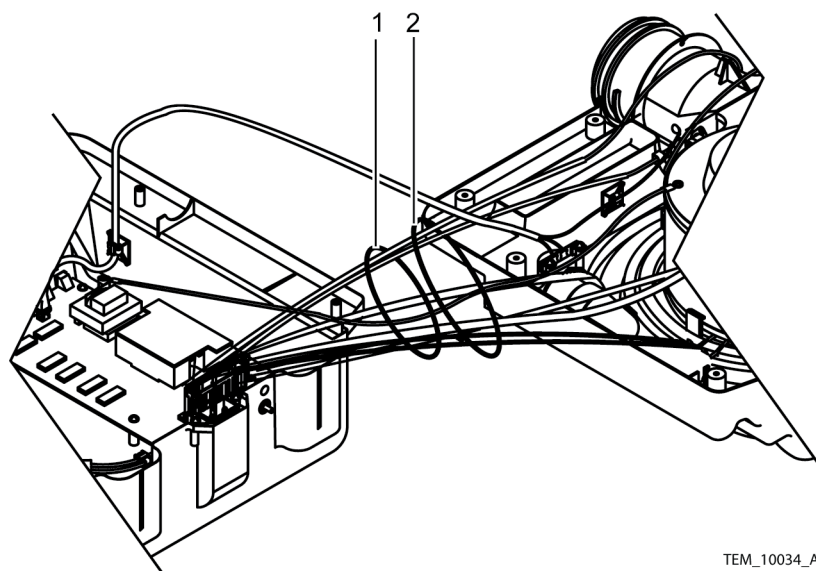

TEM_10034_A

Figure 5-48. Separated Covers

10. Disconnect the 9-pin connector from the Control PCB (Figure 5-49, item 1).

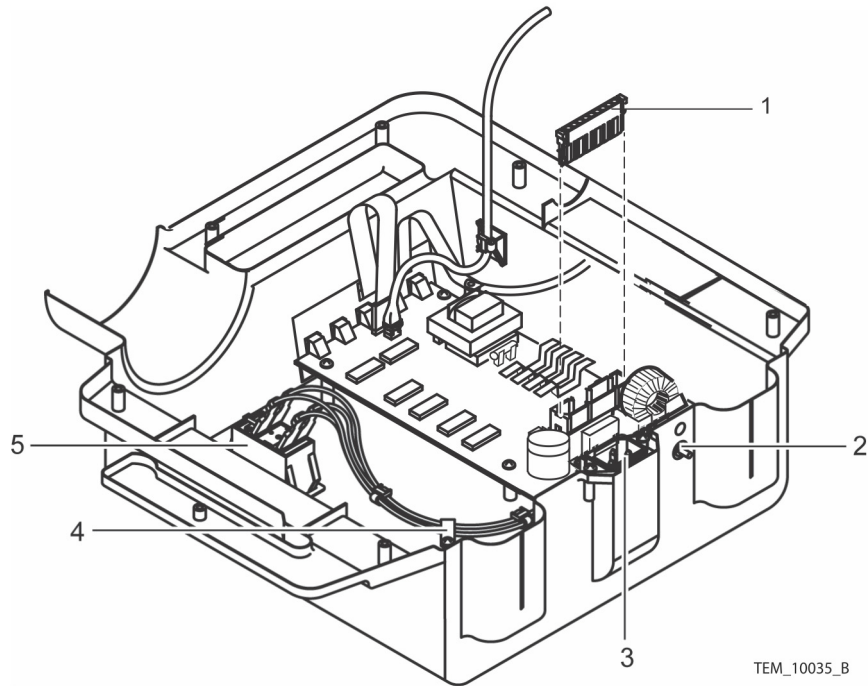

- | | | | |
|---|-------------------------------|---|-----------------------------------|
| 1 | 9-Pin Connector | 4 | Cable Clamp |
| 2 | Equipotential Ground Terminal | 5 | Boost Temperature Select Terminal |
| 3 | AC Power Connector | | |

Figure 5-49. Front Cover Assembly

11. Disconnect the wires from the equipotential ground stud (Figure 5-49, item 2).
 12. Remove the AC power connector from the front cover assembly (Figure 5-49, item 3).
 13. Remove the cable clamp from the front cover assembly (Figure 5-49, item 4).



Caution

Write down the color code of each wire connected to the power switch. This will ensure that the wires will be reconnected properly.

14. Disconnect the four wires from the power switch (Figure 5-49, item 5).
 15. Cut the cable tie. See Figure 5-50, item 1.

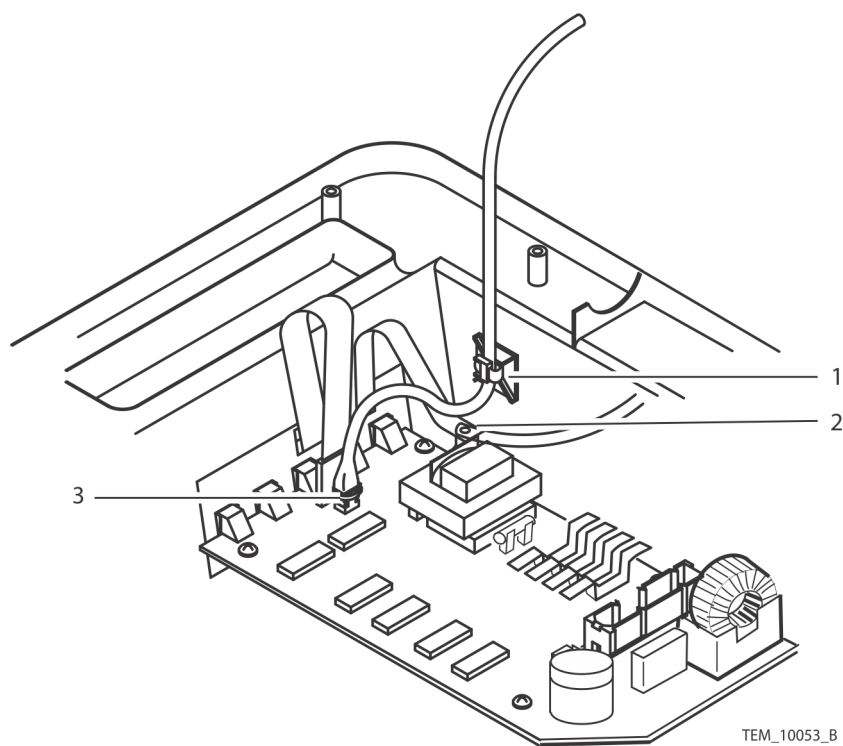

Figure 5-50. Cable Disconnect

16. Remove the ground screw. See Figure 5-50, item 2.
17. Disconnect the thermistor cable connector. See Figure 5-50, item 3.
18. Place the front cover assembly in a safe place.



Caution

The thermistor is very delicate and easily damaged. Use extreme care when handling, removing or replacing the thermistor.

19. Remove the thermistor cable terminal board. See Figure 5-51, item 2.

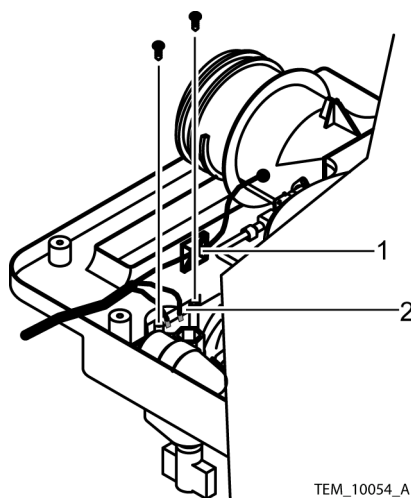

Figure 5-51. Thermistor Cable Removal

20. Cut the cable tie on the thermistor cable. See Figure 5-51, item 1.



NOTE:

The blower assembly is held onto the rear cover assembly by four screws and four clips. It is easier for two people to release the clips and lift the blower assembly from the rear cover assembly.

21. Remove the screws holding the blower assembly to the rear cover assembly. See Figure 5-52.

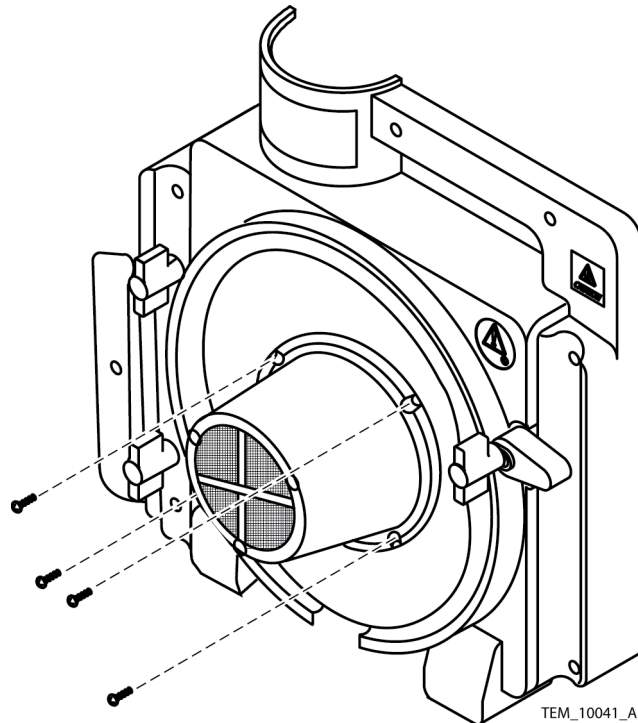

Figure 5-52. Blower Assembly Screws

22. Loosen the nut holding the capacitor to the rear cover assembly. See Figure 5-53.

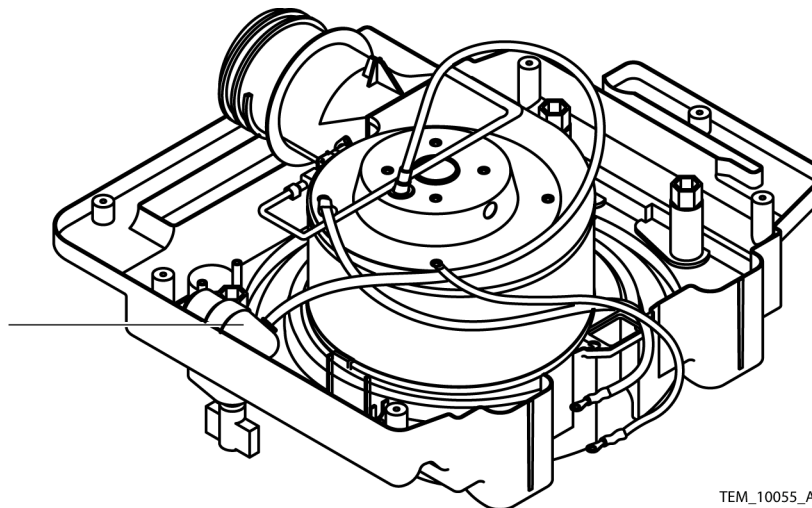

Figure 5-53. Blower Capacitor

- Lift the capacitor free of the rear cover assembly.

**NOTE:**

The thermistor cable is fragile. When handling the adapter duct, apply as little tension as possible to the thermistor cable to avoid damaging wires or its mechanical connection to the duct.

- Carefully pull the adapter duct up to remove it from the blower outlet. Take care not to pull the thermistor cable out of the adapter duct when removing the duct from the outlet.
- Rotate the blower motor assembly clockwise to disengage two of the four clips. See Figure 5-54 and Figure 5-55.

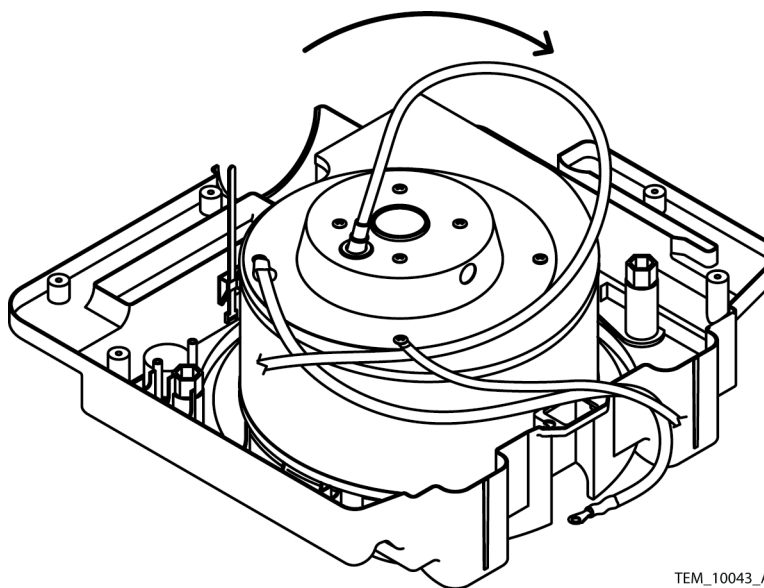

TEM_10043_A

Figure 5-54. Blower Motor Removal

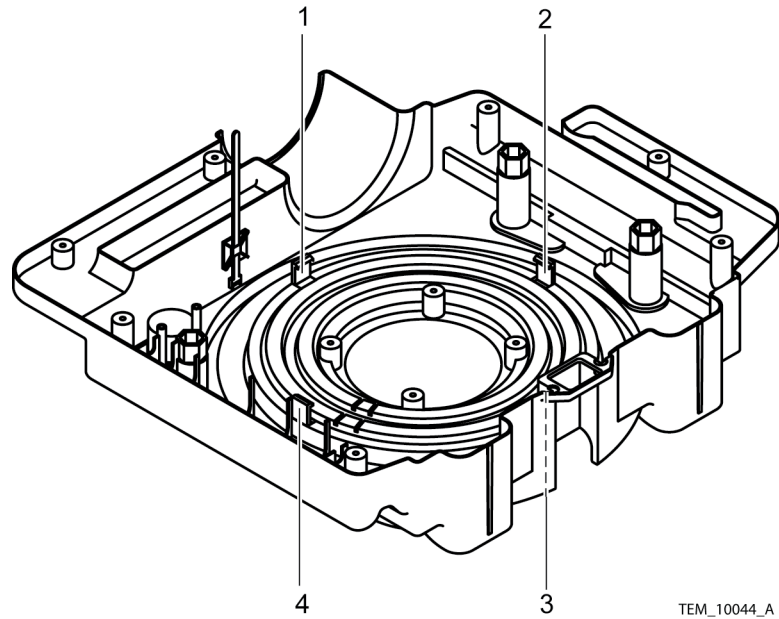

Figure 5-55. Blower Assembly Clips

26. Slide the blower motor assembly away from the engaged clips to disengage them.
27. Remove the rubber gasket from the rear cover assembly.

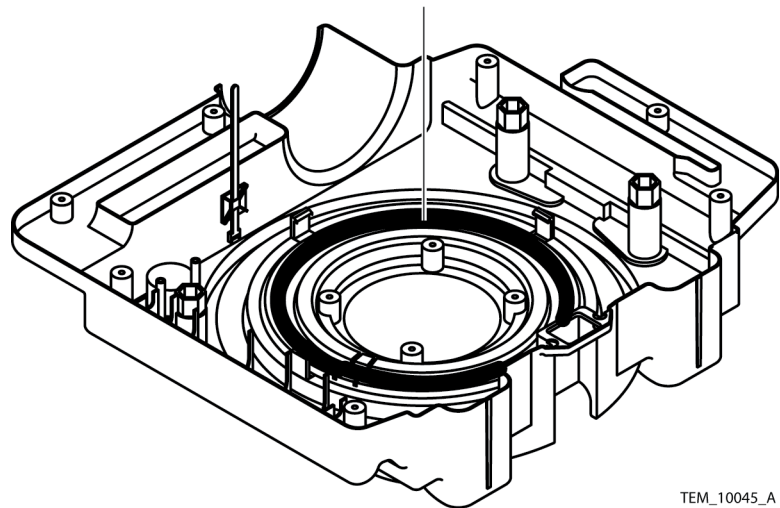

Figure 5-56. Rubber Gasket



Caution

Do not touch the heater coil. Oil from your fingers may cause damage to the heater coil when it is in use.

28. Lift the heater assembly (Figure 5-57, item 1) out of the rear cover assembly.

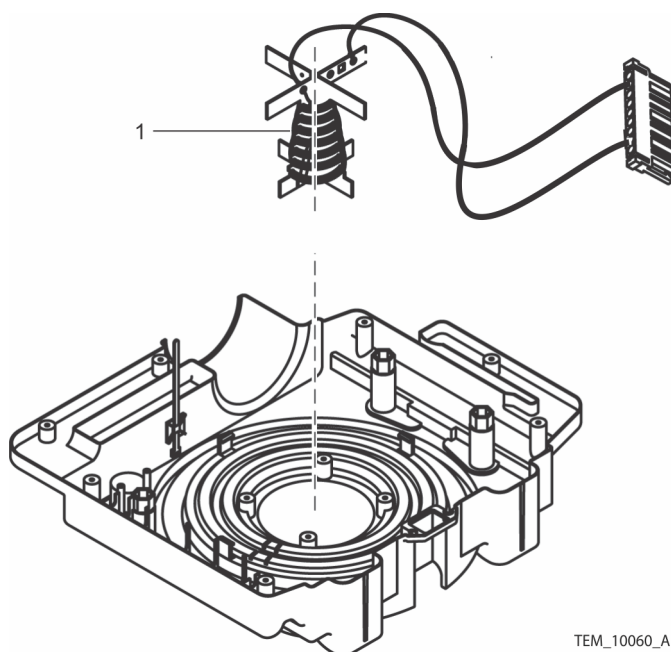

Figure 5-57. Heater Assembly

29. Discard the old rear cover assembly.



NOTE:

Ensure that the heater temperature sensor (Figure 5-58, item 1) is oriented upward when reinstalling the heater in the rear cover assembly.

30. Slide the heater into the replacement rear cover assembly, as shown in Figure 5-58.

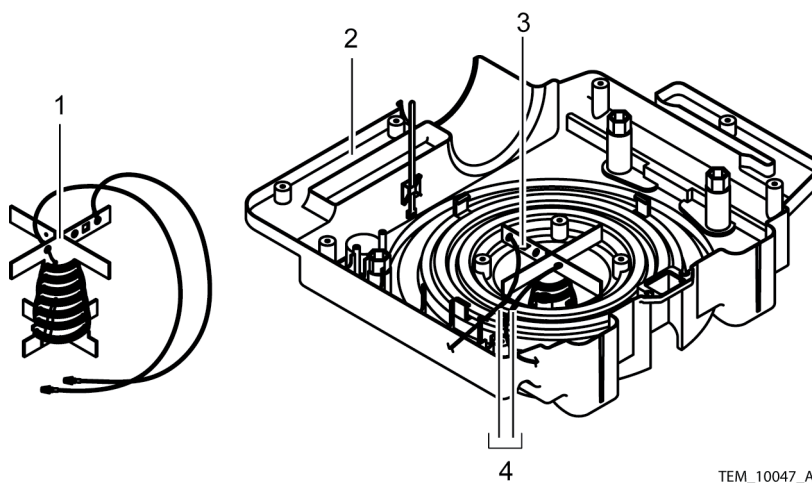
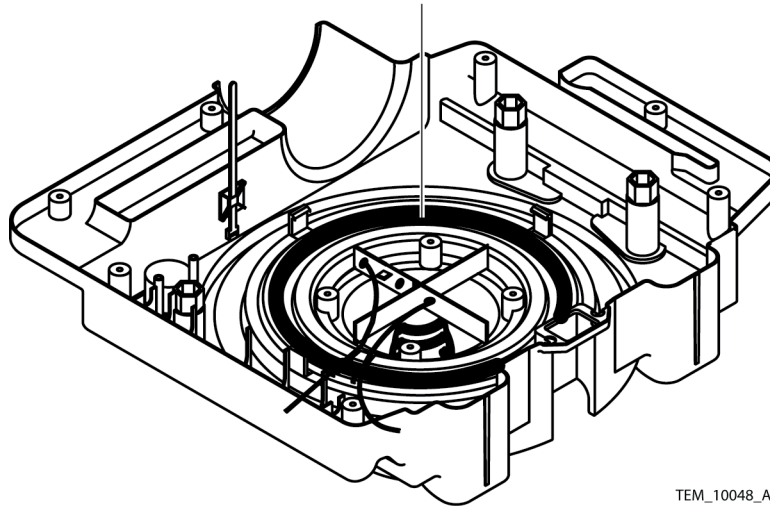

Figure 5-58. Heater Assembly Installation

31. Route the wires from the heater through the cut-outs in the rear cover assembly. See Figure 5-58, item 3.

32. Place the rubber gasket into the rear cover assembly, with the wire indentations over the heater wires. See Figure 5-59, item 1.



TEM_10048_A

Figure 5-59. Rubber Gasket

33. Place the blower assembly into the rear cover assembly and ensure that the blower assembly clips (shown in Figure 5-60) attach over the edges of the blower assembly.

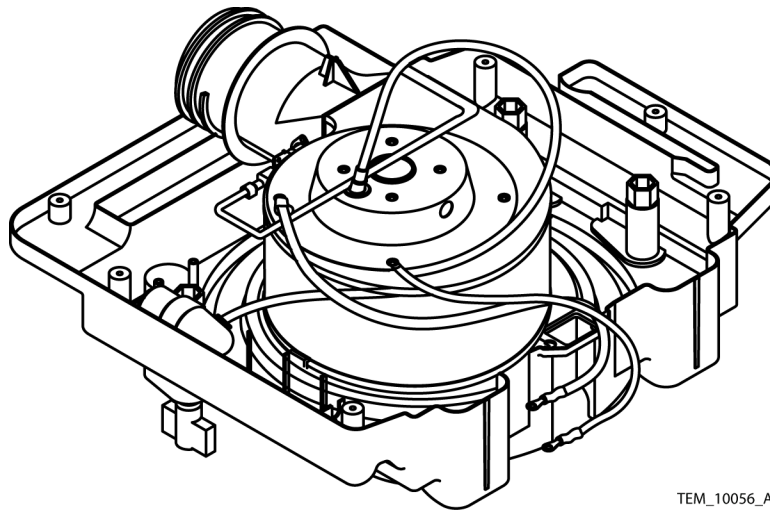

TEM_10056_A

Figure 5-60. Blower Installation



NOTE:

The thermistor cable is fragile. When handling the adapter duct, apply as little tension as possible to the thermistor cable to avoid damaging wires or its mechanical connection to the duct.

34. Carefully place the square end of the adapter duct into the blower outlet and snap the duct into place, taking care not to damage the thermistor cable.
35. Install the blower assembly mounting screws into the rear cover assembly. Tighten the screws to 4 to 6 in/lbs (10 to 15 cm/kg). See Figure 5-61.

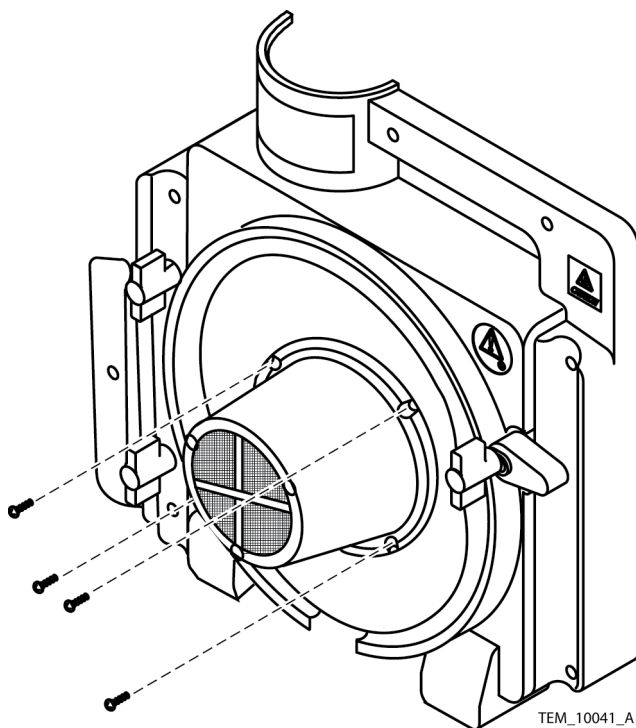

Figure 5-61. Blower Screws

36. Attach the cable tie around the thermistor cable. See Figure 5-62, item 1.

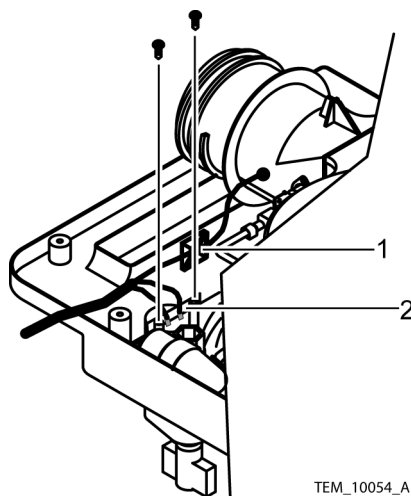

Figure 5-62. Thermistor Cable Installation

37. Install the thermistor cable terminal board. Tighten the screw to 4 to 6 in/lbs (10 to 15 cm/kg). See Figure 5-62, item 2.



Caution

Do not over tighten the capacitor nut. Over tightening the capacitor nut will cause the plastic rib to crack.

38. Install the capacitor in the rear cover assembly and tighten the nut to 7 to 10 in/lbs (18 to 25 cm/kg). See Figure 5-63, item 1.

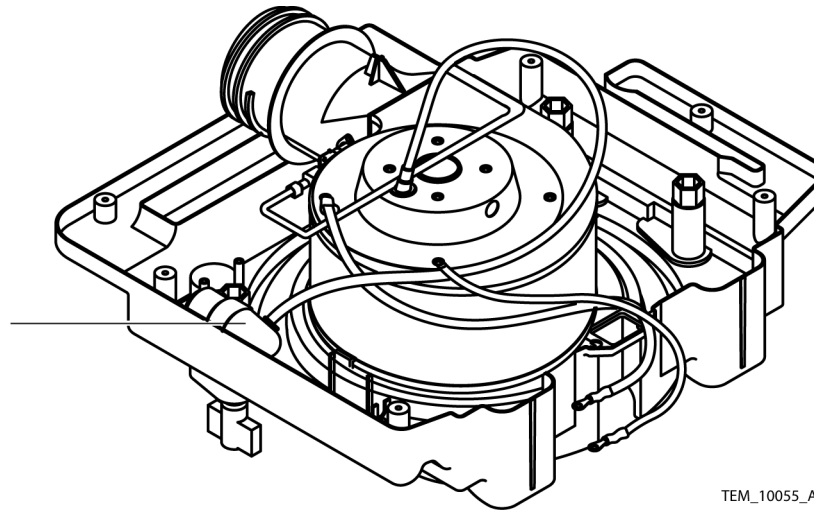

Figure 5-63. Capacitor Installation

39. Install the cable tie around the capacitor. See Figure 5-63.



NOTE:

Perform steps 40 through 49 only if steps 9 through 18 were performed earlier, and the front and rear halves of the warming system have been completely detached from each other. If steps 9 through 18 were not performed, skip to step 50.

40. Connect the thermistor cable to the Control PCB. See Figure 5-64, item 3.

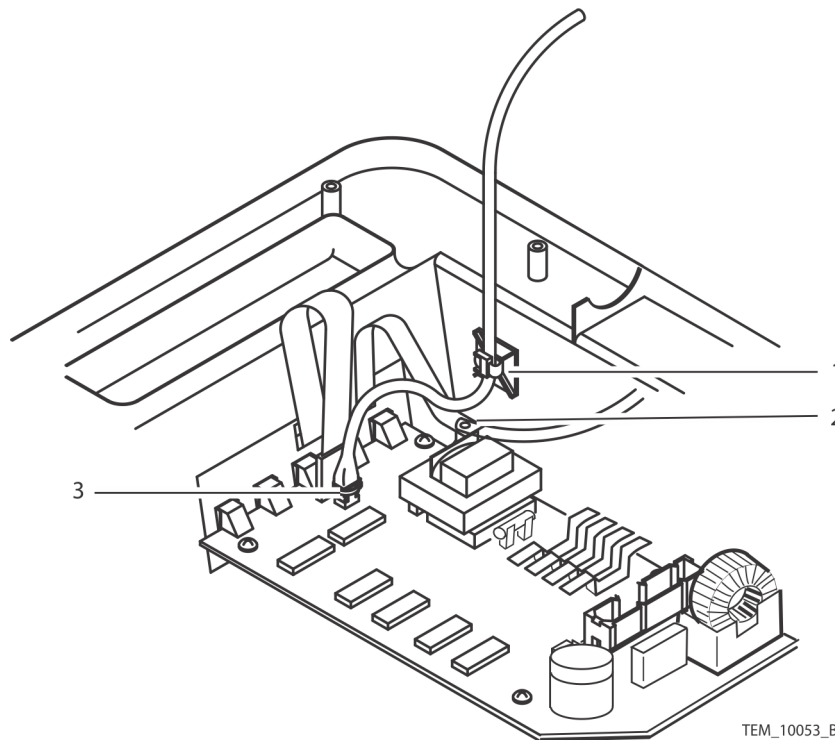

Figure 5-64. Cable Connections

41. Fasten a cable tie around the thermistor cable connector. See Figure 5-64, item 3.
42. Connect the key pad ground strap and the blower ground wire. Tighten the screw to 4 to 6 in/lbs (10 to 15 cm/kg). See Figure 5-64, item 2.
43. Install the cable tie around the thermistor cable. See Figure 5-64, item 1.
44. Connect the four wires to the power switch. Make sure to reconnect the wires in the same way they were connected before; refer to the list of wire colors and where they were connected to the switch, as recorded in Step 14. See Figure 5-65, item 5.

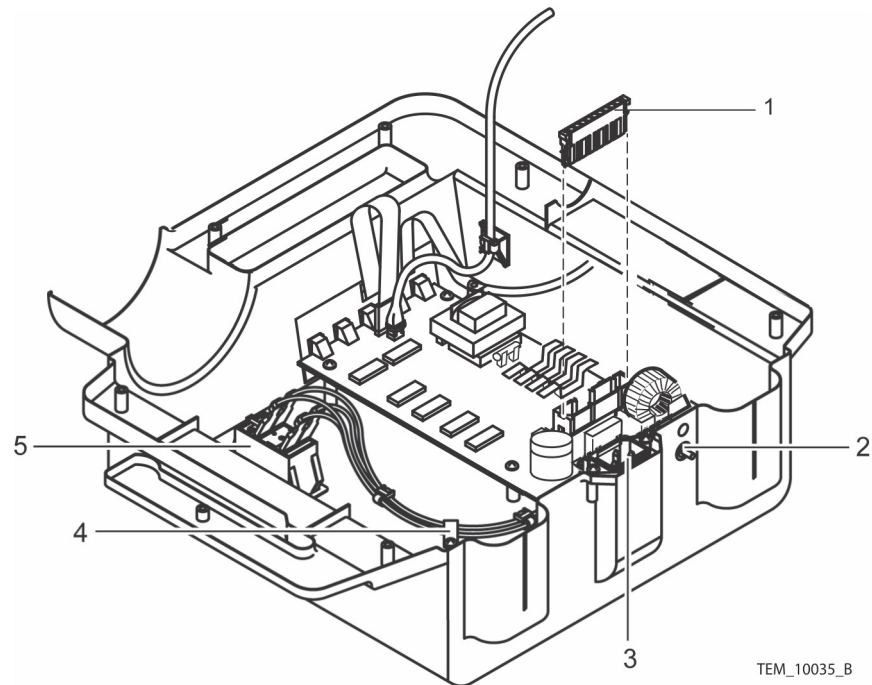
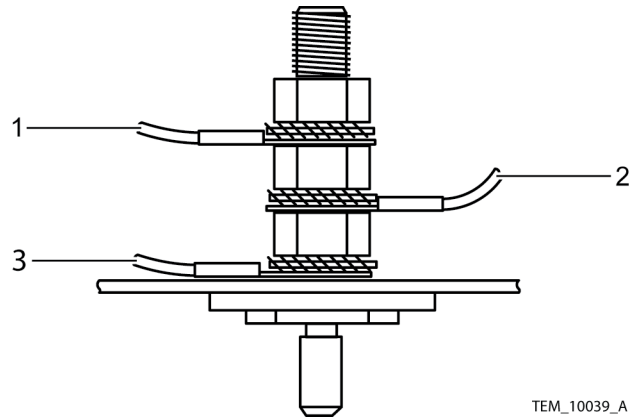

Figure 5-65. Front Cover Assembly

45. Install the cable clamp around the power switch wires (Figure 5-65, item 4).
46. Install the AC power connector into the front cover assembly. Tighten the screws to 4 to 6 in/lbs (10 to 15 cm/kg). See Figure 5-65, item 3.
47. Connect the 9-pin connector to the Control PCB (Figure 5-65, item 1).
48. Connect the ground wires to the equipotential ground stud (Figure 5-65, item 2) in the order shown in Figure 5-66. Tighten the nuts to 36 to 44 in/lbs (91 to 112 cm/kg).



TEM_10039_A

- 1 Blower Housing Ground
- 2 Blower Motor Ground
- 3 AC Power Connector Ground

Figure 5-66. Equipotential Ground Stud Wiring

49. Install the cable harness bundle ties. See Figure 5-67, items 1 and 2.

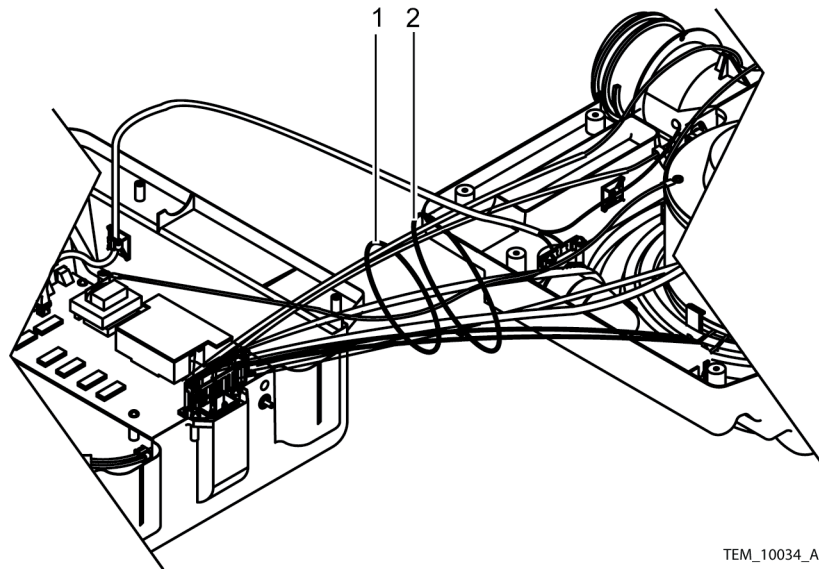

TEM_10034_A

Figure 5-67. Cable Harness Bundle Ties

50. Rejoin the front and rear covers. See page 5-5, *Rejoining the Front and Rear Covers*.

51. Place the filter assembly into the rear cover assembly.



Figure 5-68. Filter Installation

52. Install the filter cover assembly on the rear cover assembly. Tighten the screws to 8 to 12 in/lbs (20 to 30 cm/kg). See page 5-49.

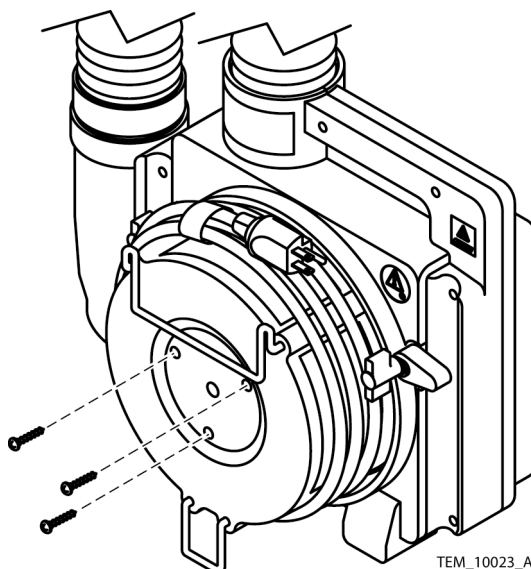

Figure 5-69. Filter Cover Installation

53. Install the power cord on the warming system, inserting the female connector into its socket on the warming system housing, and seating the cord in the routing bracket on the filter cover. If necessary, use the head of a flat blade screwdriver to separate the halves of the routing bracket sufficiently to allow seating of the cord.
54. Perform the following checks/tests to verify proper operation of the warming system prior to returning it into service:
- *Power Fail / Start Alarm Check* on page 4-1
 - *Thermostat Protection Check* on page 4-2
 - *Output Temperature Check* on page 4-4
 - *Safety Tests* on page 4-6

This page is intentionally blank.

Spare Parts & Accessories

6.1 Overview

This chapter provides information on spare parts and accessories for the WarmTouch™ Model WT-5900 patient warming system, as well as how to order them.

6.2 Ordering Information

The warming system and blankets may be ordered from Covidien Technical Services (1.800.635.5267) or your local representative.

Table 6-1: Spare Parts and Accessories

Description	Item Number Figure 6-1	Item Number Figure 6-2	Part Number
AC Inlet / EMI Filter		20	SP10001335
AC Power Switch / Breaker		23	SP169-1801
Blower Assembly, 230V		18	SP10034565
Cart	3		5022900
Connector Assembly		15	168-1202SP
Control Panel		13	SP169-1202
Duct Adapter Assembly		17	168-0205SP
Filter Cover Assembly	8		168-0202SP23
Front Cover Assembly	2	2	168-0201SP2
Fuse, 0.32 amps		21	169-5800
Heater Assembly		19	168-5803SP
HEPA Filter (5900)	9		502-2200
Hose	1		502-2000
I.V. Clamp and Foot	4		168-0203SP
I.V. Clamp Knob	5		168-2005SP
Nozzle	11		502-2100
Nozzle Strap with Clip	12		SP312-0070
PCB, 5900 WT, Service		22	SPGR100306
Power Cord (EU)	7		502-2500
Power Cord (UK)			901518CI
Rear Cover Assembly	6	6	168-0200SP23
Strap, Hook and Loop	10		168-2023
Thermostat, Disc 50° ZEA		16	SP169-0220
Thermistor Assembly		14	SP169-0211

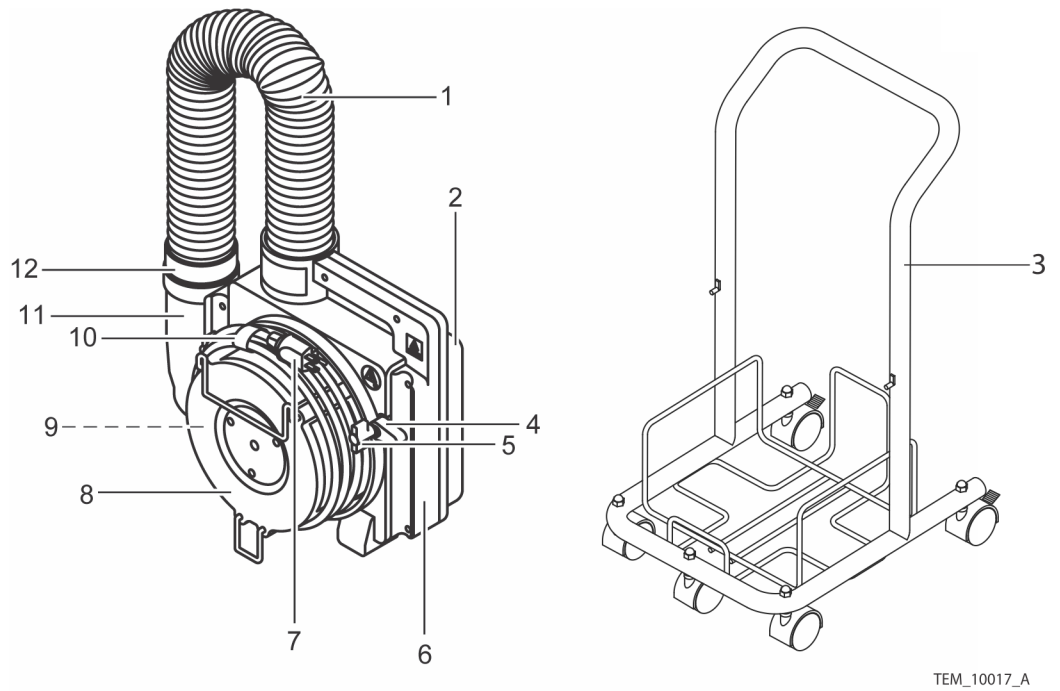

Figure 6-1. Spare Parts (Sheet 1)

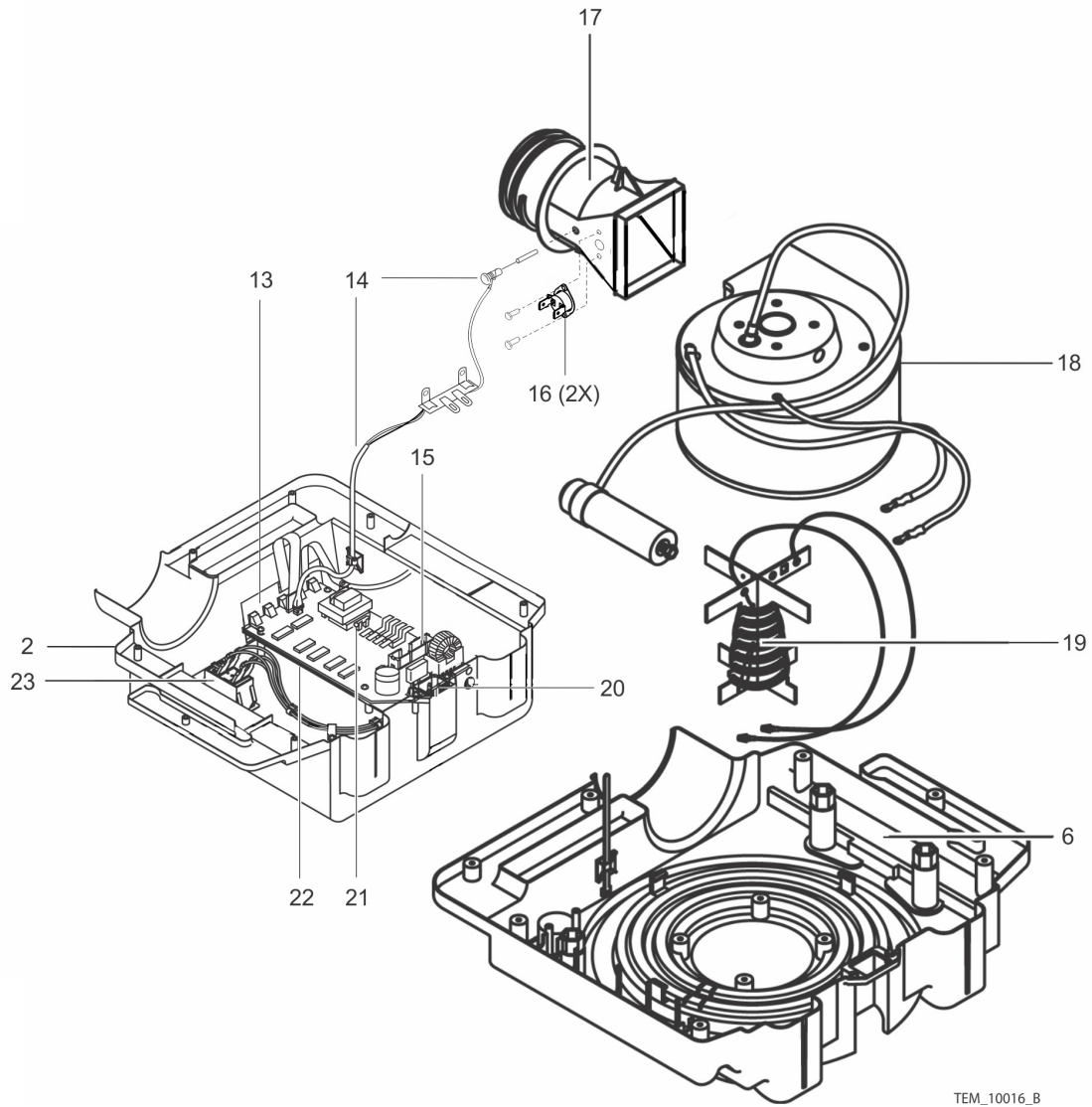

Figure 6-2. Spare Parts (Sheet 2)

6.3 Replacement Parts and Accessories

Warming system replacement parts and accessories are listed on the Internet at:

<http://www.respiratorysolutions.covidien.com>

6.4 Manual Availability

The most recent revision of this manual is available on the Internet at:

<http://www.respiratorysolutions.covidien.com>

Packing for Shipment

7.1 Overview

To ship the WarmTouch™ Model WT-5900 patient warming system for any reason, follow the instructions in this chapter.

7.2 Returning the Warming System

Prior to shipping the warming system, contact Covidien Technical Services or your local Covidien representative for shipping instructions, including a Returned Goods Authorization (RGA) number. Mark the shipping carton and any shipping documents with the RGA number.

Return the warming system by any shipping method that provides proof of delivery.

If possible, ship the warming system in its original shipping carton. If the original carton is not available, use a suitable carton with appropriate packing material to protect the warming system during shipping. North American customers may also contact the Covidien Technical Services Department to obtain a replacement shipping carton.

Pack the warming system carefully. Failure to follow the packing instructions in this section may result in loss or damage not covered by any applicable Nellcor warranty.

7.3 Repacking in Original Carton

If available, use the original carton and packing materials. See Figure 7-1.



NOTE:

Use tape or staples on the packing inserts to ensure they retain their form.

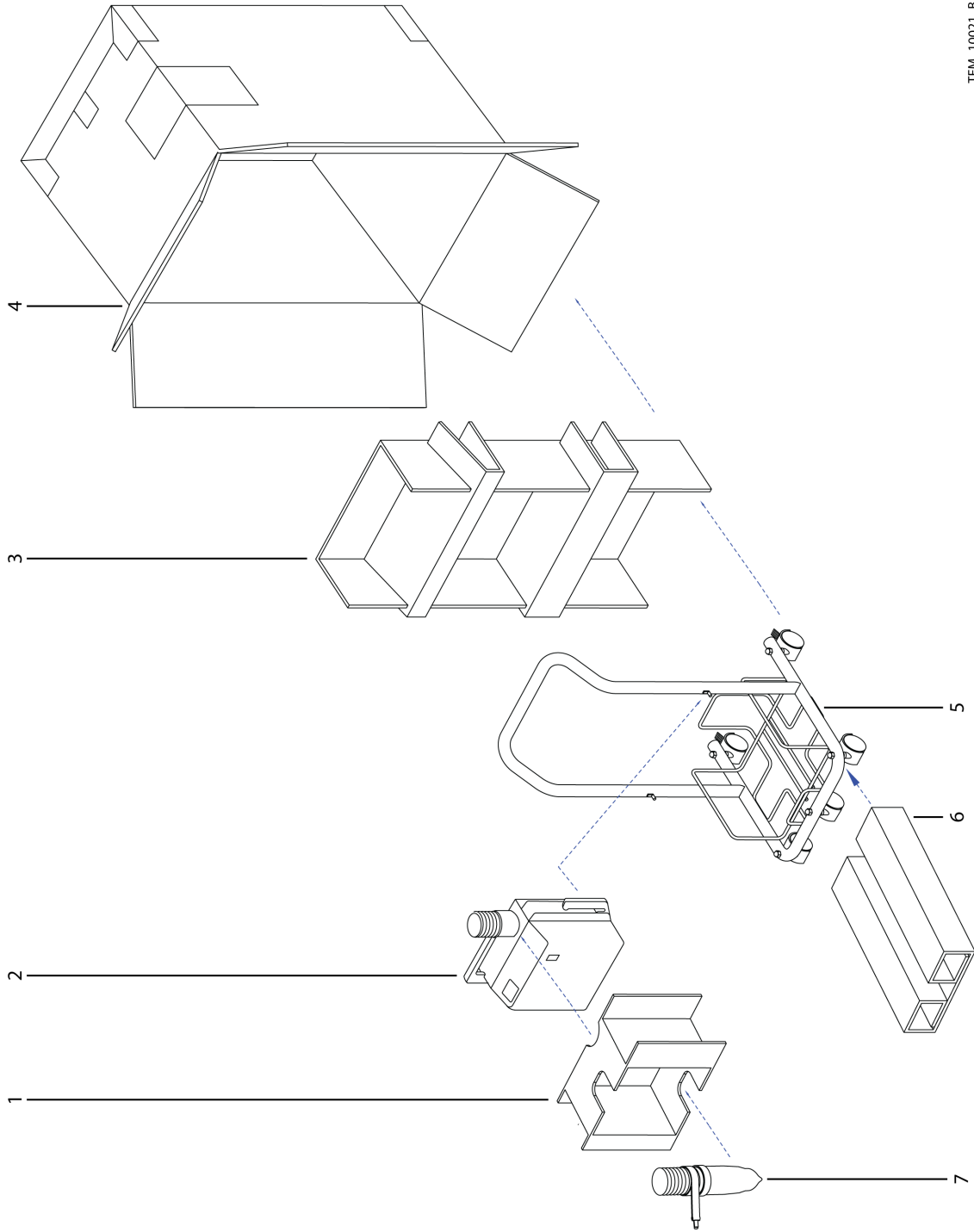

Figure 7-1. Packing the Warming System in Original Carton

To pack the warming system (refer to Figure 7-1):

1. Place the full length insert (item 3) into the box (item 4), with the wide side gap on the right.
2. Slide the base support insert (item 6) into the bottom of the box, with the ribs facing up.
3. Make sure the warming system (item 2) is mounted onto the cart (item 5). Refer to the *WT-5900 Patient Warming System Operator's Manual* for details.
4. Slide the warming system and cart into the box, with the handle to the rear and the bottom of the cart frame resting on the base support insert.
5. Place the hose insert (item 1) over the warming system, with the wide flange on the right side and the shallow cutout resting against the hose outlet.
6. Route the collapsed hose from the blower and set the nozzle end (item 7) into the two deep cutouts in the hose insert. The nozzle should be in the lower of the two cutouts, above the cart base.
7. Seal carton with packing tape.
8. Label carton with shipping address, return address, and RGA number.

7.4 Repacking in a Different Carton

If the original carton is not available, use the following procedure to pack the warming system:

1. Locate a corrugated cardboard shipping carton with a bursting strength of at least 200 pounds per square inch (psi).
2. Fill the bottom of the carton with at least 2 inches of packing material.
3. Place the warming system on the layer of packing material and fill the box completely with packing material.
4. Seal carton with packing tape.
5. Label carton with the shipping address, return address, and RGA number.

This page is intentionally blank.

Specifications

8.1 Overview

This chapter contains physical and operating specifications for the WarmTouch™ Model WT-5900 patient warming system.

8.2 Warming System Specifications

No special transport or storage methods are required for the WarmTouch™ Model WT-5900 patient warming system.

Table 8-1: System Specifications

Warming Blanket Specifications	
Maximum blanket surface temperature	44°C
Blower Specifications	
Dimensions	38 cm x 41 cm x 28 cm (15 inches x 16 inches x 11 inches)
Weight	6.8 kgs (15 lbs.)
Power Requirements	220 - 230 VAC, 50 - 60 Hz, 6 A
Automatic Temperature Stepdown (Boost to High Temperature)	After 45-minutes of continuous use blower will step down from Boost to High setting.
Power Supply Cord	4.26 m (14 feet)
Thermal Protection	Thermostat (internal): 47°C - 50 °C (117°F - 122°F)
Ambient Blower Operating Temperature Range	18°C - 28°C (64.4°F - 82.4°F)
Over Temperature Alarm Level	65 dB at 3 meters
Protection Against Ingress of Fluids	Ordinary

Table 8-1: System Specifications (continued)

Warming Blanket Specifications	
Cart Specifications	
Weight	3.1 kg (6.8 pounds)
Height	67.1 cm (26.4 inches)
Width	32.3 cm (12.7 inches)
Depth	38.6 cm (15.2 inches)

8.3 Transport and Shipping in Shipping Container

Table 8-2: Shipping Container Specifications

Temperature	-40°C to 70°C (-40°F to 158°F)
Altitude	-390 m to 6,096 m (-1,280 ft. to 20,000 ft.)
Barometric Pressure	500 hPa to 1,060 hPa (375 mmHg to 795 mmHg)
Relative Humidity	15% to 95% (non-condensing)

8.4 Compliance

Table 8-3: Compliance Standards

Item	Compliant With
Equipment classification	IEC/EN 60601-1 2nd edition CSA C22.2 No. 601.1 M90 UL 60601-1 1st edition IEC 60601-2-35: 1996 EN 60601-2-35: 1997
Type of protection	Class I
Degree of protection	Type BF - Applied part
Mode of operation	Continuous
Electromagnetic Compatibility	IEC/EN 60601-1-2 3rd edition

8.5 Manufacturer's Declaration



Warning

The use of accessories and cables other than those specified may result in increased emission and/or decreased immunity of the WT-5900.

The warming system is suitable for use in the specified electromagnetic environment. The customer and/or user of the warming system should ensure it is used in the prescribed electromagnetic environment.

8.6 Electromagnetic Compatibility (EMC)

8.6.1 Electromagnetic Emissions

Table 8-4: Electromagnetic Emissions Guidelines

Emissions Test	Compliance	Electromagnetic Environment Guidance
RF emission CISPR 11	Group 1, Class A	This is a class A product per IEC CISPR 11 and is not intended to be used in a residential environment. If used in a domestic environment, this equipment may not offer adequate protection to radio-frequency communication services. The user may be required to take mitigation measures, such as relocating or re-orienting the equipment.
Harmonic emissions IEC/EN 61000-3-2	N/A	The warming system is suitable for use in all establishments other than domestic and those directly connected to the public low-voltage power supply network that supplies buildings used for domestic purposes.
Voltage fluctuation/ flicker emissions IEC/EN 61000-3-3	N/A	

8.6.2 Electromagnetic Immunity

These guidelines may not apply in all situations. Electromagnetic propagation is affected by absorption and reflection from structures, objects, and people.

Table 8-5: Electromagnetic Immunity Guidelines

Immunity Test	EN 60601-1-2 Test Level	Compliance Level	Electromagnetic Environment Guidance
Electrostatic discharge (ESD) IEC/EN 61000-4-2	±6 kV contact ±8 kV air	±6 kV contact ±8 kV air	Floor should be wood, concrete, or ceramic tile. If floors are covered with synthetic material, the relative humidity should be at least 30%.
Electric fast transient/burst IEC/EN 61000-4-4	±2 kV for power supply lines ±1 kV for input/output lines	±2 kV for power supply lines ±1 kV for input/output lines	Mains power quality should be that of a typical commercial and/or hospital environment.
Surge EN 61000-4-5	±1 kV differential mode ±2 kV common mode	±1 kV differential mode ±2 kV common mode	Mains power quality should be that of a typical commercial and/or hospital environment.

Table 8-5: Electromagnetic Immunity Guidelines (continued)

Immunity Test	EN 60601-1-2 Test Level	Compliance Level	Electromagnetic Environment Guidance
Voltage dips, short interruptions and voltage variations on power supply IEC/EN 61000-4-11	<5% U_T (>95% dip in U_T) for 0.5 cycle	<5% U_T (>95% dip in U_T) for 0.5 cycle	Mains power quality should be that of a typical commercial and/or hospital environment. If the user of the warming system requires continued operation during power mains interruption, it is recommended that the warming system be powered from an uninterruptible power supply or battery. Note: U_T is the AC mains voltage prior to application of the test level.
	40% U_T (60% dip in U_T) for 5 cycles	40% U_T (60% dip in U_T) for 5 cycles	
	70% U_T (30% dip in U_T) for 25 cycles	70% U_T (30% dip in U_T) for 25 cycles	
	<5% U_T (95% dip in U_T) for 5 sec.	<5% U_T (95% dip in U_T) for 5 sec.	
Power frequency (50/60 Hz) magnetic field IEC/EN 61000-4-8	3 A/m	3 A/m	It may be necessary to position the warming system further from the sources of power frequency magnetic fields or to install magnetic shielding. The power frequency magnetic field should be measured in the intended installation location to assure that it is sufficiently low.

For transmitters rated at a maximum output power not listed, estimate the separation distance using the equation in the corresponding column, where P is the maximum output (power rating of the transmitter in watts [W]) according to the transmitter manufacturer.

**NOTE:**

Portable and mobile RF communications equipment should be used no closer to any part of the warming system, including cables, than the recommended separation distance calculated from the equation appropriate for the frequency of the transmitter.

Table 8-6: Recommended Separation Distances

	Frequency of Transmitter		Equation for Separation Distance
Radiated RF EN 61000-4-3	3 V/m 80 MHz 800 MHz	3 V/m	Distance = $0.35\sqrt{P}$ 80 MHz to 800 MHz
	3 V/m 800 MHz 2.5 GHz	3 V/m	Distance = $0.7\sqrt{P}$ 800 MHz to 2.5 GHz
Conducted RF EN 61000-4-6	3 Vrms 150 kHz 80 MHz	3 Vrms	Distance = $1.2\sqrt{P}$ 150 kHz to 80 MHz
Rated Maximum Output Power of Transmitter in Watts	Separation Distance in Meters According to Transmitter Frequency		
	150 kHz to 80 MHz	80 MHz to 800 MHz	800 MHz to 2.5 GHz
0.010	0.120	0.035	0.070
0.100	0.380	0.110	0.220
1.000	1.200	0.350	0.700
10.000	3.800	1.120	2.210
100.000	12.000	3.500	7.000

8.7 Ground Integrity Test

Without power cord: $\leq 100 \text{ m } \Omega$

With power cord: $\leq 200 \text{ m } \Omega$

8.8 Earth Leakage Current Test

Table 8-7: Earth Leakage Current Test

AC Polarity	Line Cord	Neutral Cord	Leakage Current
Normal	Closed	Closed	500 μ A
Reversed	Closed	Closed	500 μ A
Normal	Open	Closed	1000 μ A
Normal	Closed	Open	1000 μ A

8.9 Enclosure Leakage Current Test

Table 8-8: Enclosure Leakage Current Test

AC Line Cord	Neutral Line Cord	Power Line Ground Cable	AAMI / ANSI Standard ES1
Normal	Closed	Closed	100 μ A
Normal	Closed	Open	500 μ A
Normal	Open	Closed	500 μ A
Reversed	Closed	Closed	100 μ A
Reversed	Open	Closed	500 μ A
Reversed	Closed	Open	500 μ A

Principles of Operation

9.1 Overview

This chapter provides information on various circuits and other components of the WarmTouch™ Model WT-5900 patient warming system.

9.2 Control Panel

The control panel features four manually switched temperature settings, as well as a warning light (see Figure 9-1). The selected temperature is indicated by an LED indicator.



TEM_10003_A

Figure 9-1. Control Panel

Each temperature setting represents the average temperature of air at the duct inlet. The four temperature settings are:

- Low: 32 °C (89.6 °F)
- Medium: 38 °C (100.4 °F)
- High: 43 °C (109.4 °F)
- Boost: 45 °C (113 °F) for 45 minutes

The warning light on the control panel indicates that the warming system has detected a fault. When the warning light is lit, the warming system will also sound an alarm. See page 2-2, *Alarms* for a detailed description of the alarm system.

9.3 Main Circuit Board

See Figure A-1 and Figure A-2 (in the *Appendix*) for the schematic diagram of the warming system main circuit board. The main circuit board consists of:

- DC power supply circuit
- Control logic circuit
- Automatic temperature stepdown
- Alarm driver circuits
- Temperature control circuit
- Liquid crystal display (LCD) hour meter

There are three connectors on the main circuit board:

- J1 – connects the main circuit board to the control panel
- J2 – connects the main circuit board to the AC power line circuit, the heater, and the blower
- J3 – connects the temperature control circuit of the main circuit board to:
 - YS1 400 series thermostat
 - Over-temperature test port

9.3.1 DC Power Supply Circuit

The 220 - 230 VAC enters the main circuit board through J2, pins 3 and 4. The power supply circuit consists of:

- F1 fuse, located in the primary of the transformer
- D7 bridge rectifier
- VR1 12 VDC voltage regulator



Warning

Dangerous voltages (220 - 230 VAC) are exposed during this procedure. Exercise extreme care not to come in contact with the 220 - 230 VAC.

In case of warming system failure (no lights), the presence of 12 VDC should be verified. This can be done by opening the warming system. Refer to page 5-3, *Separating the Front and Rear Covers*.

Connect a voltmeter to test points TP2 and TP3 (TP2 is 12 VDC; TP3 is ground). Both test points are located on the circuit board assembly directly below the transformer (T1).

9.3.2 Control Logic Circuit

The control logic circuit for temperature settings consists of:

- U1 and U2 logic gates
- U4 inverter
- U3 dual R-S latch
- U5 quad switch, bilateral

9.3.3 Automatic Temperature Stepdown

The temperature setting automatically lowers from boost to high after 45-minutes of continuous use. See Figure A-1 and Figure A-2 in the *Appendix*. This circuit consists of:

- U6 24-stage digital logic frequency divider
- Two gates of U4 inverter
- R14 timing setup potentiometer

9.3.4 Alarm Drive Circuits

The over-temperature alarm drive circuit consists of:

- U9B comparator
- U8 optocoupler (senses the status of the temperature limit thermostats)
- Q1 FET
- SPKR1 speaker
- U12 dual timer
- Q6 FET
- D8 warning LED

The power fail alarm drive circuit consists of:

- U14 logical AND gate
- U13 dual timer power start indicator
- Q7 FET
- D8 warning LED
- U12 dual timer
- Q5 FET
- SPKR1 speaker

9.3.5 Temperature Control Circuit

The temperature control circuit consists of:

- U7 comparator
- U9 comparator
- Q2 triac (controls the heater)
- U10 optocoupler (switches Q2)

See *Output Temperature Check* procedure on page 4-4.

9.3.6 LCD Hour Meter

The warming system is equipped with an hour meter that is located on the front cover. The meter displays the number of hours the warming system has been in use. See Figure 9-2.



Figure 9-2. Hour Meter AC Power Section

The warming system operates from a 220 - 230 VAC power source. Input power selection consists of a circuit breaker/rocker switch located on the front of the warming system and a line filter/power cord receptacle located at the bottom of the warming system. Power enters the main circuit board at J2, pins 3 and 4. The input voltage drives three major sections of the warming system:

- DC power supply
- heater
- blower

9.3.7 Blower

The blower is connected to the main circuit board through connector J2, pins 6, 7 and 9.

9.3.8 Heater

The heater section consists of a heater element (1,000 Watts) and an over-temperature thermostat that will open if the blower fails to operate.

9.3.9 Thermostat Protection

There are two thermostats (A and B) located at the exit of the blower. Thermostats A and B are redundant systems and, if necessary, will automatically turn the heater off when the output temperature exceeds a set level. This condition lights the Warning light on the control panel, and turns on an audible alarm. Refer to *Thermostat Protection Check on page 4-2*.

9.3.10 Over-Temperature Test Port

The over-temperature test port is located on the back panel of the warming system. The test port is used to verify the thermostat protection circuitry. Refer to *Thermostat Protection Check on page 4-2*.

Appendix

Replace this page and the next page with 11x17 foldout page:

Page A-1 - Figure A-1. Warming System Schematic (Sheet 1)

Page A-2 - Figure A-2. Warming System Schematic (Sheet 2)

Figure A-1. Warming System Schematic (Sheet 1)

Figure A-2. Warming System Schematic (Sheet 2)

Index

A

- AC power section 9-4
- Accessories web address 6-4
- Automatic shutdown 2-2

B

- Background information 2-1
- Blower 9-4
- Burn hazard 1-2

C

- Cleaning 3-5
- Control logic circuit 9-2
- Control PCBA replacement 5-14
- Customized warming therapy 2-2

D

- DC power supply circuit 9-2
- Disinfection 3-5
- Duct adapter assembly replacement 5-31

E

- Earth leakage current test 4-6
- Electric shock 1-2
- Electric shock hazard 1-2
- Electromagnetic compatibility (EMC) 8-3
- Electromagnetic emissions 8-3
- Electromagnetic immunity 8-3
- Enclosure leakage current test 4-6
- Explosion hazard 1-2

F

- Filter cover assembly replacement 5-2
- Fire hazard 1-2
- Front and rear covers, rejoining 5-5
- Front and rear covers, seperating 5-3
- Front cover assembly replacement 5-7

G

- Ground integrity test 4-6
- Ground stud 4-6

H

- Heater 9-4
- Heater assembly replacement 5-18
- HEPA filter 3-3

- HEPA filter replacement 3-1
- Hose replacement 5-30

I

- Intended use 2-1

L

- LCD hour meter 9-3

M

- Main circuit board 9-2
- Manual availability 2-1
- Manufacturer's declaration 8-2
- MRI Warning 1-3

N

- Nozzle replacement 3-4

O

- Operating hours meter 3-2
- Ordering information 6-1, 8-1
- Output temperature check 4-4
- Over-temperature test port 9-4

P

- Patient burns 1-2
- Possible explosion hazard 1-2
- Possible patient injury 4-3
- Power cord replacement 3-3
- Power cord routing 3-4
- Power fail / start alarm check 4-1

R

- Rear cover assembly replacement 5-35
- Repacking, different carton 7-3
- Repacking, original carton 7-1
- Replacement parts web address 6-4
- Returning goods authorization (RGA) number 7-1
- Returning the WT-5900 7-1

S

- Safety Features 2-2
- Safety information 1-1, 2-2, 3-1, 4-1, 8-1, 9-1
- Safety tests 4-6
- Schematic A-1, A-2
- Single patient use 1-2

Specifications

earth leakage current	8-6
enclosure leakage current	8-6
general	8-1
ground integrity	8-5
Surface cleaning	3-5

T

Temperature control circuit	9-3
Thermostat protection	9-4
Thermostat protection check	4-2

W

Warning light	2-2
Warnings	1-2, 2-2, 4-3, 5-1, 8-2, 9-2

Rx
ONLY



CE
0123

Part No. 10076216 Rev. A

COVIDIEN, COVIDIEN with logo and Covidien logo are U.S. and/or internationally registered trademarks of Covidien AG.

™* Trademark of its respective owner.
Other brands are trademarks of a Covidien company.

©2011 Covidien.

 Covidien llc,
15 Hampshire Street, Mansfield, MA 02048 USA.
 Covidien Ireland Limited,
IDA Business & Technology Park, Tullamore.

www.covidien.com

[T] 1-800-635-5267