

# Alaris™ GH Guardrails® Syringe Pump

Models: 80023UNxx-G, 80023NWxx-G

Directions For Use  
en

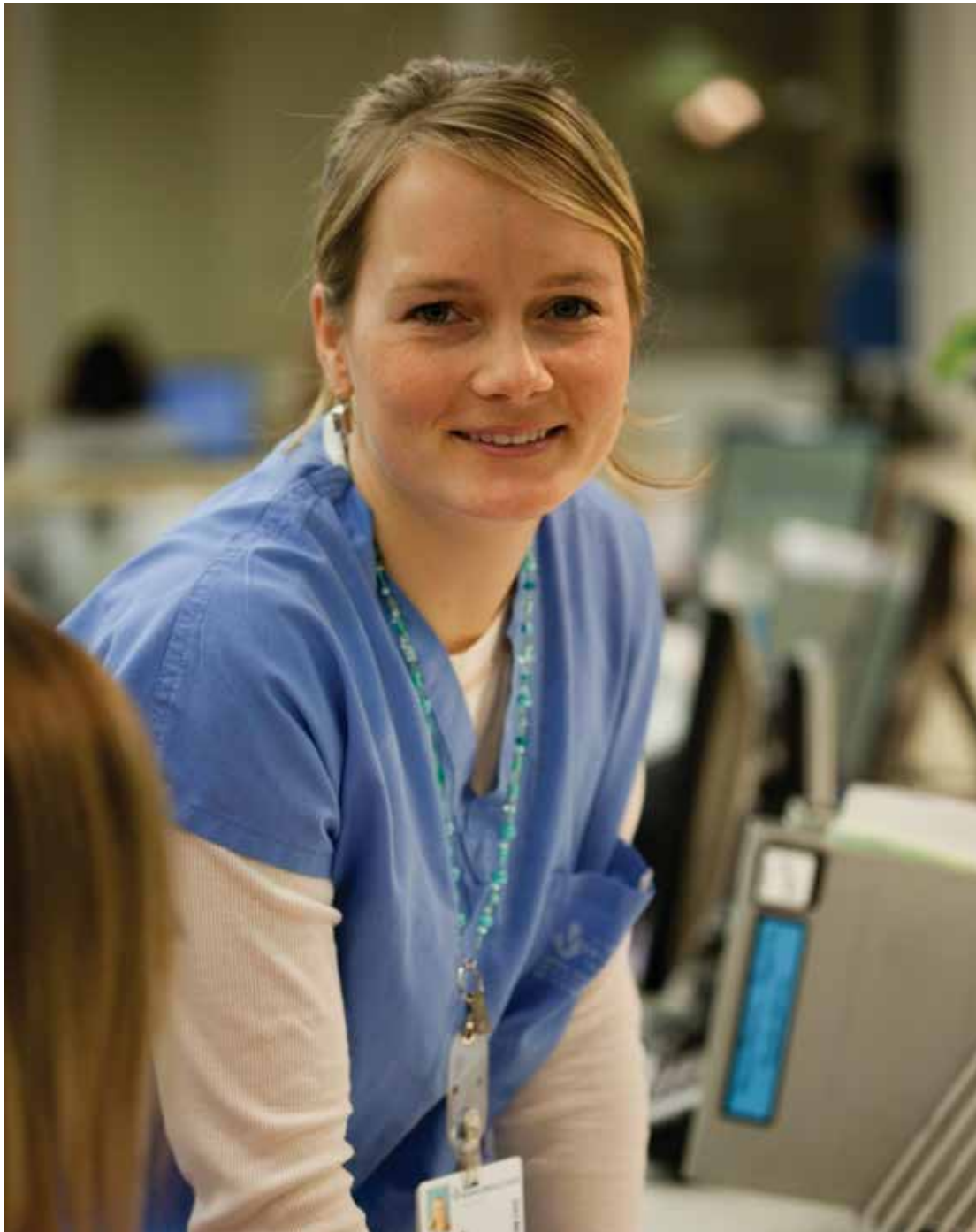

CE  
0086

 CareFusion

# Contents

	<b>Page</b>
Introduction .....	2
About This Manual .....	2
Creating a Data Set .....	3
Features of the Alaris® GH Guardrails® Syringe Pump .....	4
Controls & Indicators .....	5
Symbol Definitions .....	6
Main Display Features .....	7
Operating Precautions .....	8
Getting Started .....	10
Basic Features .....	17
Alarms and Warnings .....	20
Prompts .....	21
Configured Options .....	22
Specifications .....	25
Recognised Syringes .....	26
Associated Products .....	27
Compatible Extension Sets .....	28
Maintenance .....	30
Occlusion Pressure Limits .....	32
IrDA, RS232 and Nurse call Specification .....	33
Trumpet Curves & Start-up Curves .....	34
Products and Spare Parts .....	35
Service Contacts .....	36

## Introduction

The Alaris® GH Guardrails® Syringe Pump (herein after referred to as "pump") is a fully featured syringe pump suitable for critical care and general infusion applications.

The Alaris® GH Guardrails® Syringe Pump functions with a wide range of standard, single-use, disposable Luer-lock syringes together with extension sets. It accepts syringe sizes from 5ml to 50ml. A full list of compatible syringes can be found in the Compatible Syringes section. A list of recommended extension sets can be found in the Compatible Extension Sets section.

The Guardrails® Safety Software for the Alaris® GH Guardrails® Syringe Pump brings a new level of medication error prevention to the point of patient care. The Guardrails® Safety Software allows the hospital to develop a best-practice Data Set of IV medication dosing guidelines for patient-specific care areas, referred to as profiles. Each profile contains a specific library of drugs, as well as pump configurations appropriate for the care area. A profile also contains either Guardrails® Hard Limits that cannot be overridden during infusion programming, or Guardrails® Soft Alerts that can be overridden, based on clinical requirements.

The hospital defined Data Set is developed and approved through pharmacy and clinical input, and then configured into the Alaris® GH Guardrails® Syringe Pump by qualified technical personnel.

The Alaris® GH Guardrails® Syringe Pump, with a Data Set loaded, provides automatic alerts when a dosing limit, bolus limit, concentration limit, or weight limit has been exceeded. These safety alerts are provided without the need for the pump to be connected to a PC or network.

### Intended Purpose

The Alaris® GH Guardrails® Syringe Pump is intended for use by medical staff for purposes of controlling infusion rate and volume.

### Conditions of Use

The Alaris® GH Guardrails® Syringe Pump should only be operated by a clinician competent in use of automated syringe pumps and post-placement management of intravenous catheters.



**CareFusion cannot guarantee the continued system accuracy with other manufacturer's syringes as identified in the 'Compatible Syringes' table. Manufacturers may change syringe specification significant to system accuracy without prior notification.**

### Indications

The Alaris® GH Guardrails® Syringe Pump is indicated for infusion of therapeutics including:

- analgesics
- antimicrobials
- blood products
- chemotherapy
- subcutaneous
- nutrition

### Contraindications

The Alaris® GH Guardrails® Syringe Pumps is contraindicated for:

- enteral therapies
- epidural

## About This Manual

The user must be thoroughly familiar with the Alaris® GH Guardrails® Syringe Pump described in this manual prior to use.

All illustrations used in this manual show typical settings and values which may be used in setting up the functions of the pump. These settings and values are for illustrative use only. Where stated, a minimum infusion rate refers to a nominal rate of 1.0ml/h, and an intermediate infusion rate refers to a nominal rate of 5.0ml/h. The complete range of infusion rates, settings and values are shown in the Specifications section.



**It is important to ensure that you only refer to the most recent version of the Directions for Use and Technical Service Manual for your CareFusion products. These documents are referenced on [www.carefusion.com](http://www.carefusion.com). Copies can be obtained by contacting your local CareFusion representative.**

## Creating a Data Set

To use the Alaris® GH Guardrails® Syringe Pump a Data Set will need to be developed, reviewed, approved, released, uploaded and verified according to the following process. Refer to the Guardrails® Editor Directions For Use (1000PB01398) for further details and operating precautions.

### 1. Create Master Lists (Using Guardrails® Editor)

<i>Master Drugs*</i>	A list of drug names and standard concentrations. The Software can store an unlimited number of entries depending on disk space. Note: When using a combination of two or more drugs, the dose rate can only be configured for one drug. Up to 19 characters are available to name the drug or the combination.
<i>Syringe Library</i>	Configure syringes enabled for use.

### 2. Create Care Area Profiles (Using Guardrails® Editor)

<i>Drug Library*</i>	Drugs and concentrations for a Profile with minimum & maximum limits and occlusion alarm level. Up to 100 drug set-ups can be entered for each of the available 10 Profiles.
<i>Configuration**</i>	Pump configuration settings, General Options and Units for Dosing Only.

### 3. Review, Approve and Release Data Set (Using Guardrails® Editor)

<i>Review and Approve</i>	Entire Data Set Report to be printed, reviewed and signed as proof of approval by an authorised person, according to Hospital protocol. Signed printout to be kept safe by hospital for use during verification procedure.
<i>Release</i>	Data Set status to be promoted to Released (Password is required).

### 4. Upload Data Set to Alaris® GH Guardrails® Syringe Pump enabled (Using Guardrails® Editor Transfer Tool)

Data Set transfers should only be performed by qualified technical personnel.

### 5. Verify Data Set Upload

<i>First or Individual Pump Verification</i>	On completion of upload, record CRC (Cyclic Redundancy Check) number shown on the Alaris® GH Guardrails® Syringe Pump. Download the Data Set from the pump using the Verification Tool. Compare Data Set downloaded with approved signed Data Set printout. Reviewer should sign the printout and also record the CRC number on the printout as a record.
<i>Subsequent Pumps Verification</i>	On subsequent uploads of the Data Set compare CRC number on pump with CRC number recorded in First Pump Verification.

\* Note: Drug parameters have to be in accordance to local regulation and prescribed information.

\*\* See important note in Configured Options section.

# Features of the Alaris® GH Guardrails® Syringe Pump

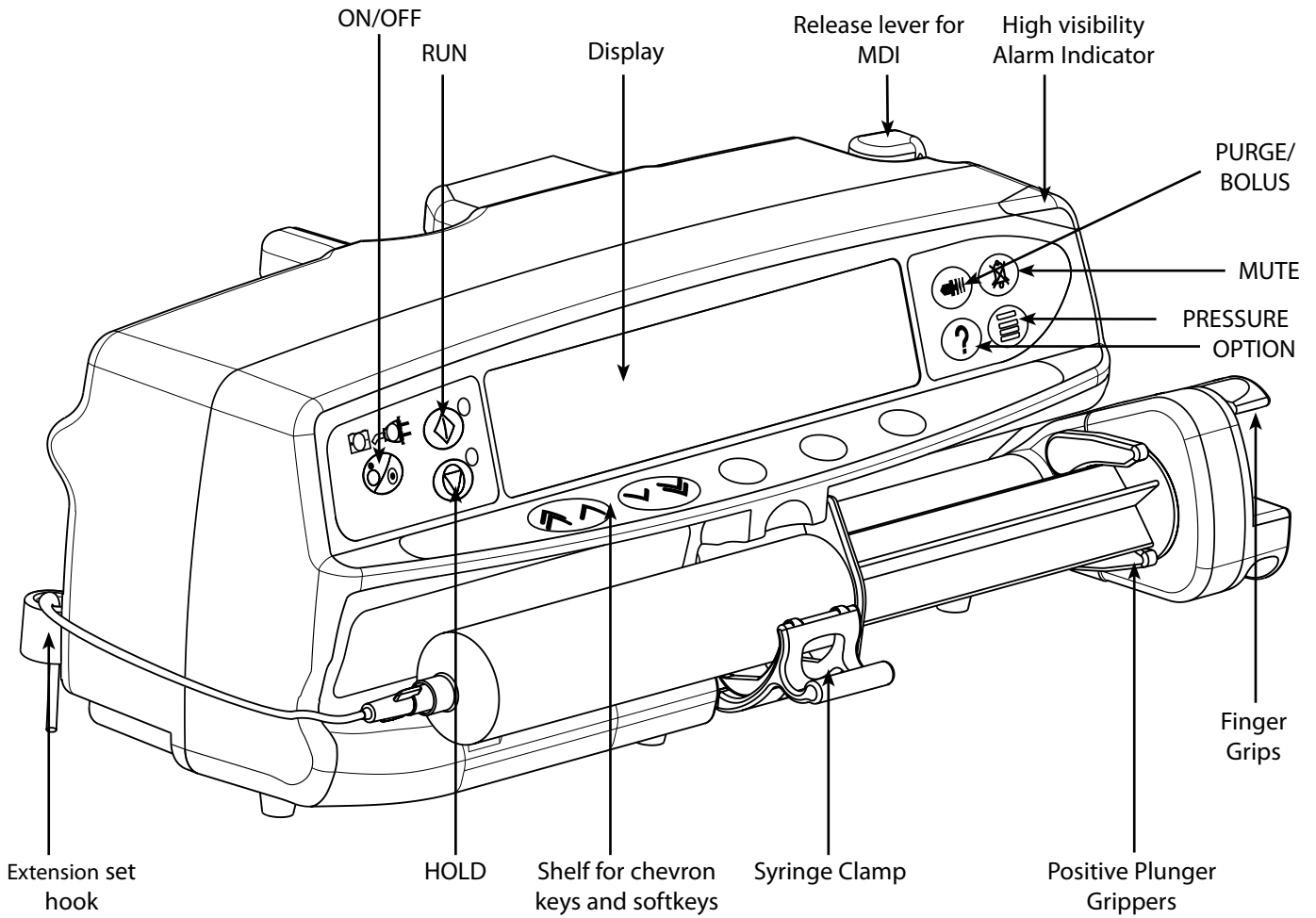



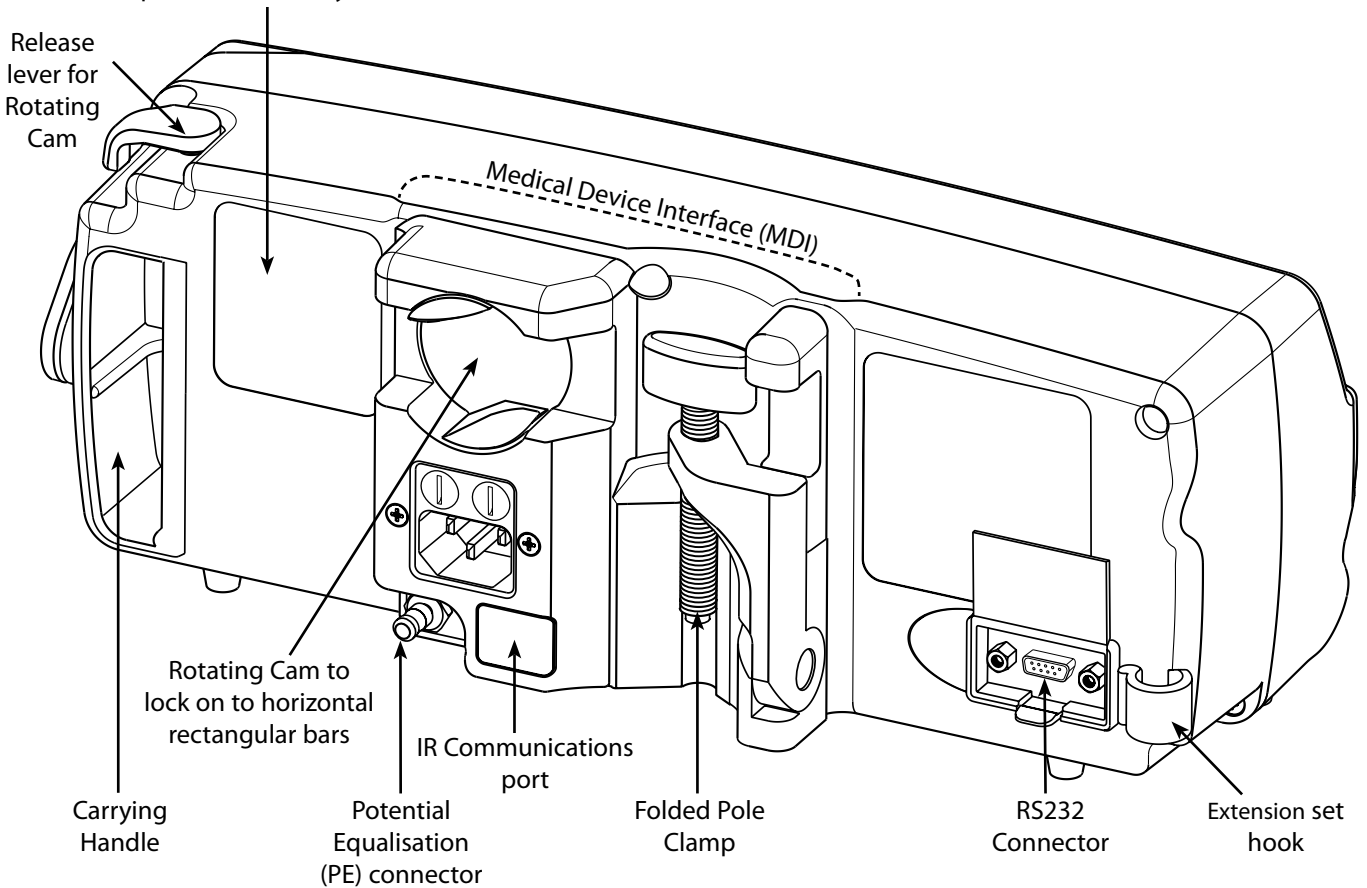



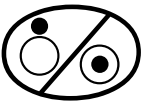

Rating Plate (see Symbol Definitions for an explanation of the symbols used)



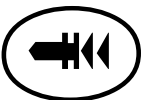

## Controls & Indicators

### Controls:













Symbol	Description
	<b>ON/OFF</b> button - Press once to switch the pump ON. Press and hold down for 3 seconds to switch the pump OFF.
	<b>RUN</b> button - Press to start the infusion. The green LED will flash during infusion.
	<b>HOLD</b> button - Press to put the infusion on hold. The amber LED will be lit while on hold.
	<b>MUTE</b> button - Press to silence alarm for 2 minutes (configurable). Press and hold until 3 beeps are heard for 15 minutes silence.
	<p><b>PURGE/BOLUS</b> button - Press to access <b>PURGE</b> or <b>BOLUS</b> soft keys. Press and hold down soft key to operate.</p> <p><b>PURGE</b> the extension set during set up.</p> <ul style="list-style-type: none"> <li>● Pump is on hold</li> <li>● Extension set is not connected to the patient</li> <li>● Volume Infused (VI) is not added</li> </ul> <p><b>BOLUS</b> - fluid or drug delivered at an accelerated rate.</p> <ul style="list-style-type: none"> <li>● Pump is infusing</li> <li>● Extension set is connected to the patient</li> <li>● VI is added</li> </ul>
	<b>OPTION</b> button - Press to access optional features (see Basic Features).
	<b>PRESSURE</b> button - Use this button to display the pumping pressure and alarm level.
	<b>CHEVRON</b> keys - Double or single for faster/slower increase or decrease of values shown on display.
	<b>BLANK SOFTKEYS</b> - Use in conjunction with the prompts shown on the display.

### Indicators:

Symbol	Description
	<b>BATTERY</b> indicator - When illuminated the pump is running on the internal battery. When flashing the battery power is low with less than 30 minutes of use remaining.
	<b>AC POWER</b> indicator - When illuminated the pump is connected to an AC power supply and the battery is being charged.

## Symbol Definitions



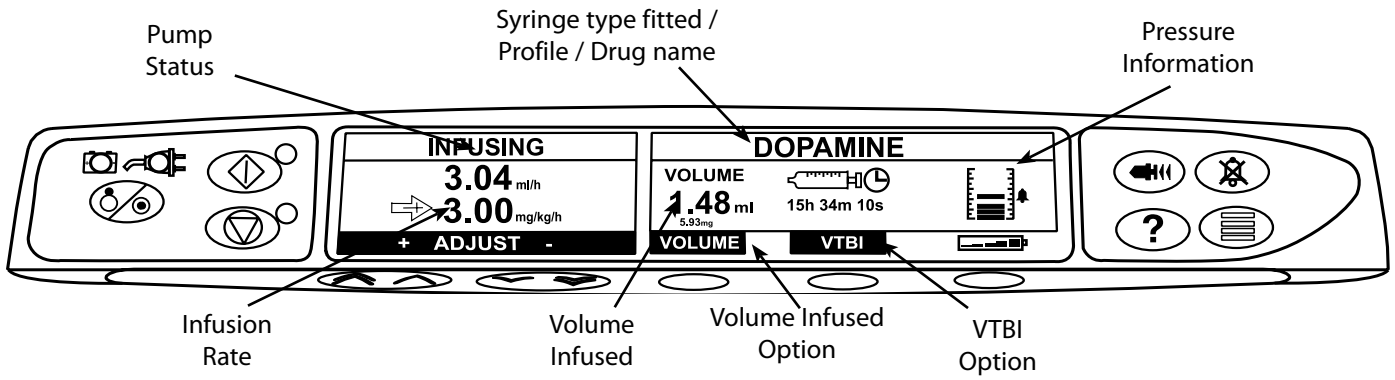

### Labelling Symbols:

Symbol	Description
	Attention (Consult accompanying documents)
	Potential Equalisation (PE) Connector
	RS232/Nurse call Connector (Optional)
	Defibrillation-proof type CF applied part (Degree of protection against electrical shock)
<b>IPX1</b>	Protected against vertically falling drops of water
	Alternating Current
	Device complies with the requirements of Council Directive 93/42/EEC as amended by 2007/47/EC.
	Date of Manufacture
	Manufacturer
	Not for Municipal Waste
	Important information
	Fuse Rating
	Authorised representative in the European Community

## Main Display Features

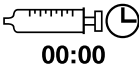

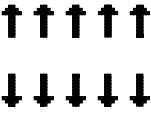
### Screen Icons:

Symbol	Description
	<b>TIME REMAINING DISPLAY</b> icon - Indicates time before syringe will require replacing.
	<b>BATTERY</b> icon - Indicates battery charge level to highlight when the battery will require recharging.
	<b>Guardrails® SOFT ALERT</b> icon - Indicates the pump is running at a rate above (pointing up) or below (pointing down) a Guardrails® Soft Alert. (Number of arrows vary depending on drug name length)
	<b>Guardrails® LIMIT WARNING</b> icon - Indicates the setting entered is not permitted as it is under or exceeds a Guardrails® Hard Limit.



## Operating Precautions

### Disposable Syringes and Extension Sets

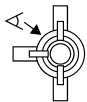
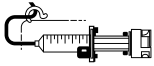
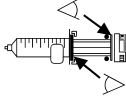
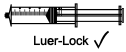

- Always clamp or otherwise isolate the patient line before unclamping or removing a syringe from the pump. Failure to do so may result in unintended administration.
- This Alaris® GH Guardrails® Syringe Pump has been calibrated for use with single-use disposable syringes. To ensure correct and accurate operation, only use 3 piece Luer lock versions of the syringe make specified on the pump or described in this manual. Use of non-specified syringes or extension sets may impair the operation of the pump and the accuracy of the infusion.
- Uncontrolled flow or syphoning may result if the syringe is located incorrectly in the pump, or if it is removed from the pump before the extension set is properly isolated from the patient. Isolation may include closing a tap in the patient line or activating a flow stop clamp.
- Secure the extension set to the pump using the extension set hook at the rear of the pump. This provides protection against accidental dislodging of the syringe from the pump.
- When combining several apparatus and/or instruments with extension sets and other tubing, for example via a 3-way tap, the performance of the pump may be impacted and should be monitored closely.

### Mounting the Pump

- When more than one pump is being used on a patient, those containing high risk, critical medications must be positioned as close to the patient's heart level as possible to avoid the risk of variations in flow or syphoning.
- Raising a Pump whilst infusing may result in a bolus of the infusate, whereas lowering a Pump whilst infusing may result in a delay in the infusion (an underinfusion).
- Do not mount the pump in a vertical position with the syringe pointing upwards as this could lead to an infusion of air which may be in the syringe. To protect against the introduction of air the user should regularly monitor the progress of the infusion, syringe, extension line and patient connections and follow the priming procedure specified herein.



### Operating Environment

- When using any infusion pump in conjunction with other pumps or devices requiring vascular access, extra care is advised. Adverse delivery of medication or fluids can be caused by the substantial variation in pressures created within the local vascular system by such pumps. Typical examples of those pumps are used during dialysis, bypass or cardiac assist applications.
- This pump is suitable for use in Hospital and clinical environments other than domestic establishments and those directly connected to the public single phase AC mains power supply network that supplies buildings used for domestic purposes. However, it may be used in domestic establishments under the supervision of Medical professionals with additional necessary appropriate measures. (Consult Technical Service Manual, appropriately trained technical personnel or CareFusion for further information).
- This pump is not intended to be used in the presence of a flammable anaesthetic mixture with air or oxygen or nitrous oxide.

### Operating Pressure

- This is a positive pressure pump designed to achieve very accurate fluid administration by automatically compensating for resistance encountered in the infusion system.
- The pumping pressure alarm system is not designed to provide protection against, or detection of, IV complications which can occur.

### Alarm Conditions

- Several alarm conditions detected by this pump will stop the infusion and generate visual and audible alarms. Users must perform regular checks to ensure that the infusion is progressing correctly and no alarms are operating.



### Guardrails® Safety Software

- The Guardrails® Safety Software incorporates dosing limits and pump configuration parameters based on hospital protocol. The software adds a test of reasonableness to drug programming based on the limits defined by the hospital. Qualified personnel must ensure the appropriateness of the drug dosing limits, the compatibility of the drugs, and the performance of each pump, as part of the overall infusion. Potential hazards include drug interactions, and inappropriate delivery rates and pressure alarms.
- When loading a Data Set with the Guardrails® Safety Software, ensure the correct profile is selected prior to starting an infusion. Failure to use the appropriate profile could cause serious consequences.

## Operating Precautions (continued)

### Electromagnetic Compatibility & Interference



- This pump is protected against the effects of external interference, including high energy radio frequency emissions, magnetic fields and electrostatic discharge (for example, as generated by electrosurgical and cauterising equipment, large motors, portable radios, cellular telephones etc.) and is designed to remain safe when unreasonable levels of interference are encountered.
- Therapeutic Radiation Equipment: Do not use the pump in the vicinity of any Therapeutic Radiation Equipment. Levels of radiation generated by the radiation therapy equipment such as Linear Accelerator, may severely affect functioning of the pump. Please consult manufacturer's recommendations for safe distance and other precautionary requirements. For further information, please contact your local CareFusion representative.
- Magnetic Resonance Imaging (MRI): The pump contains ferromagnetic materials which are susceptible to interference with magnetic field generated by the MRI devices. Therefore, the pump is not considered an MRI compatible pump as such. If use of the pump within an MRI environment is unavoidable, then CareFusion highly recommends securing the pump at a safe distance from the magnetic field outside the identified 'Controlled Access Area' in order to evade any magnetic interference to the pump; or MRI image distortion. This safe distance should be established in accordance with the manufacturers' recommendations regarding electromagnetic interference (EMI). For further information, please refer to the product technical service manual (TSM). Alternatively, contact your local CareFusion representative for further guidance.
- Accessories: Do not use any non-recommended accessory with the pump. The pump is tested and compliant with the relevant EMC claims only with the recommended accessories. Use of any accessory, transducer or cable other than those specified by CareFusion may result in increased emissions or decreased pump immunity.
- This pump is a CISPR 11 Group 1 Class A device and uses RF energy only for its internal function in the normal product offering. Therefore, its RF emissions are very low and are not likely to cause any interference with the nearby electronic equipment. However, this pump emits a certain level of electromagnetic radiation which is within the levels specified by IEC/EN60601-1-2 and IEC/EN60601-2-24. If the pump interacts with other equipment, measures should be taken to minimise the effects, for instance by repositioning or relocation.
- In some circumstances the pump may be affected by an electrostatic discharge through air at levels close to or above 15kv; or by radio frequency radiation close to or above 10v/m. If the pump is affected by this external interference the pump will remain in a safe mode; the pump will duly stop the infusion and alert the user by generating a combination of visual and audible alarms. Should any encountered alarm condition persist even after user intervention, it is recommended to replace that particular pump and quarantine the pump for the attention of appropriately trained technical personnel. (Consult Technical Service Manual for further information).



### Hazards



- An explosion hazard exists if the pump is used in the presence of flammable anaesthetics. Exercise care to locate the pump away from any such hazardous sources.



- Dangerous Voltage: An electrical shock hazard exists if the pump's casing is opened or removed. Refer all servicing to qualified service personnel.
- When connected to an external power source, a three-wire (Live, Neutral, Earth) supply must be used. If the integrity of the external protective conductor in the installation or its arrangement is in doubt, the pump should be operated from the battery.



- Do not open the RS232/Nurse Call protective covering when not in use. Electrostatic discharge (ESD) precautions are required when connecting RS232/Nurse Call. Touching the pins of the connectors may result in ESD protection failure. It is recommended that all actions must be taken by appropriately trained personnel.

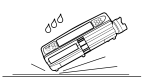

- If this pump is dropped, subjected to excessive moisture, fluid spillage, humidity or high temperature, or otherwise suspected to have been damaged, remove it from service for inspection by a qualified service engineer. When transporting or storing the pump, use original packaging where possible, and adhere to temperature, humidity and pressure ranges stated in the Specifications section and on the outer packaging.

## Getting Started



### Initial Set-up



**Before operating the pump read this Directions For Use manual carefully.**

1. Check that the pump is complete, undamaged and that the voltage rating specified on the label is compatible with your AC power supply.
2. Items supplied are:
  - **Alaris® GH Guardrails® Syringe Pump**
  - **User Support CD (Directions For Use)**
  - **AC Power Cable (as requested)**
  - **Protective Packaging**
3. Connect the pump to the AC power supply for at least 2½ hours to ensure that the internal battery is charged (verify that the  is lit).

#### Language Selection

1. On initial start-up the pump will display the Select Language screen.
2. Select the required language from the list displayed using the   keys.
3. Press the **OK** softkey to confirm your selection.



**An approved Guardrails® Safety Software Data Set must be uploaded to the Alaris® GH Guardrails® Syringe Pump prior to use. Guardrails® Editor PC Software is available separately.**

**The pump will automatically operate from its internal battery if the pump is switched on without being connected to the AC power supply.**

***Should the pump fail to perform correctly, replace in its original protective packaging, where possible and contact a qualified service engineer for investigation.***

## Getting Started (continued)



**Do not mount the pump with the AC power inlet or the syringe pointing upwards. This could affect the electrical safety in the event of a fluid spill or lead to the infusion of air which may be in the syringe.**

### Pole Clamp Installation

The pole clamp is fitted to the rear of the pump and will provide secure fixing to vertical I.V. poles of a diameter between 15 and 40 mm.

1. Pull the folded pole clamp towards you and unscrew the clamp to leave enough room for the size of the pole.
2. Place pump around pole and tighten screw until the clamp is secured to the pole.

Recessed area

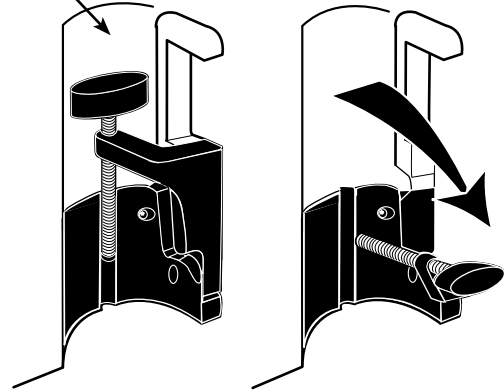

**Ensure the pole clamp is folded away and stored within the recessed area at the rear of the pump before connecting to a Docking Station/Workstation\* or when not in use.**

**Never mount the pump such that the IV infusion stand becomes top heavy or unstable.**



**Prior to each use, check the pole clamp:**

- does not show any signs of excessive wear,
- does not show any signs of excessively loose movement in the extended, mountable position.

**If these signs are observed, the pumps should be taken out of service for examination by qualified service personnel.**

### Docking Station/Workstation\* or Equipment Rail Installation

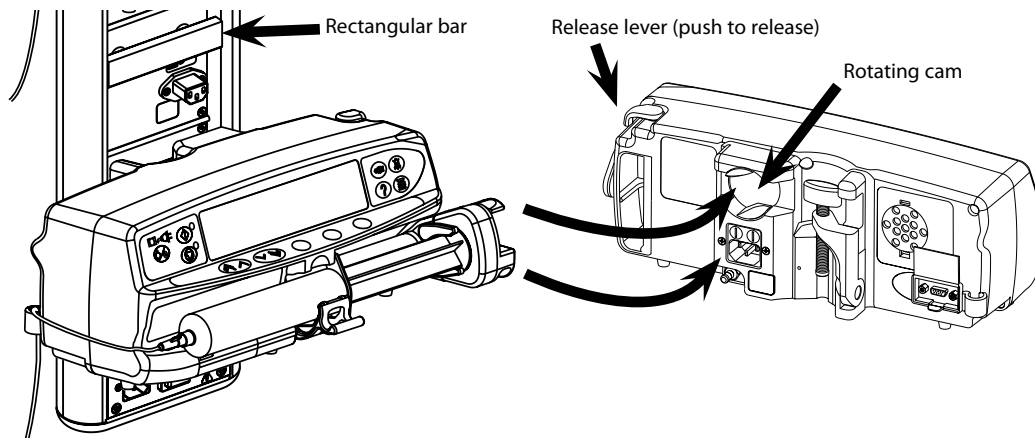

The rotating cam can be fitted to the rectangular bar on the Docking Station/Workstation\* or the equipment rail measuring 10 by 25 mm.

1. Align the rotating cam on the rear of the pump with the rectangular bar on the Docking Station/Workstation\* or the equipment rail.
2. Hold the pump horizontally, push the pump firmly onto the rectangular bar or equipment rail.

**Ensure that the pump 'clicks' securely into position onto the bar.**

3. To release, push the release lever and pull the pump forwards.

\*Alaris® DS Docking Station and Alaris® Gateway Workstation.

## Getting Started (continued)

### Syringe Loading

#### Prepare Syringe and Administration Set

To decrease potential start-up delays, delivery inaccuracies and delayed generation of occlusion alarms each time a new syringe is loaded:

- Use smallest syringe size possible, for example, if infusing 9 ml of fluid, use a 10 ml syringe.
- Use the **PURGE SYRINGE** or **PURGE** option on the Pump to decrease the delay in the start of the infusion, see *Starting the Pump* section.



**Warning:** Use the smallest compatible syringe size necessary to deliver the fluid or medication; this is especially important when infusing high risk or life-sustaining medications at low infusion rates, especially flow rates < 0.5 ml/h.



**Warning:** Purge the Pump system before starting an infusion or after replacing a near-empty syringe with a replacement syringe. When Purging ensure that the extension set is not connected to the patient.

#### Practice Recommendations:

- Tubing internal diameter: Smallbore or microbore tubing is recommended when infusing at low rates
- Filters: Internal volume, dead space, of in-line filters should be minimized
- Connection sites: Critical drugs should be connected as close to the vascular access site as possible

#### Positioning of Pump

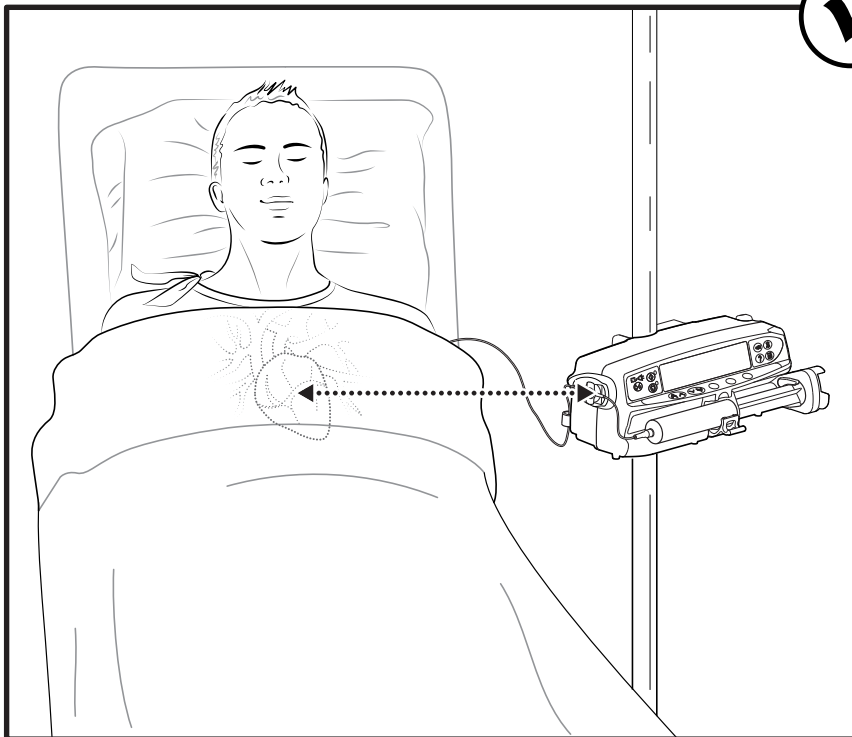

Ensure that the Pump is as close to level of patient's heart as possible.

Patient's heart level should be in line with the middle of the Pump or the pressure disc for the Alaris CC Syringe Pumps.



**Warning:** Adjusting the Pump's height relative to the patient's heart level can lead to temporary increases or decreases in fluid delivery.



**Caution:** If using multiple syringe pumps and it is not clinically feasible to have all Pumps level with the patient's heart, place the high risk or life-sustaining medications as close to the patient's heart level as possible.



**Caution:** When infusing multiple high risk or life-sustaining medications, consider placing the Pumps infusing at the lowest rates as close to the level of the patient's heart as possible.

## Getting Started (continued)

### Loading and Confirming a Syringe



**Warning:** To securely load and confirm a syringe carefully follow the steps below. An incorrect loading of a syringe may result in misidentification of the syringe type and size. If then confirmed, this may lead to significant inaccuracy of the infusion rate and may also affect pump performance.

Only use a syringe of the type stated on the pump or in this manual. Using an incorrect syringe could adversely affect the accuracy of the infusion rate and may also affect pump performance.

When drawing fluid into the syringe, draw enough to compensate for any 'dead space' volume in the extension set and syringe at the end of infusion as this cannot be fully infused.

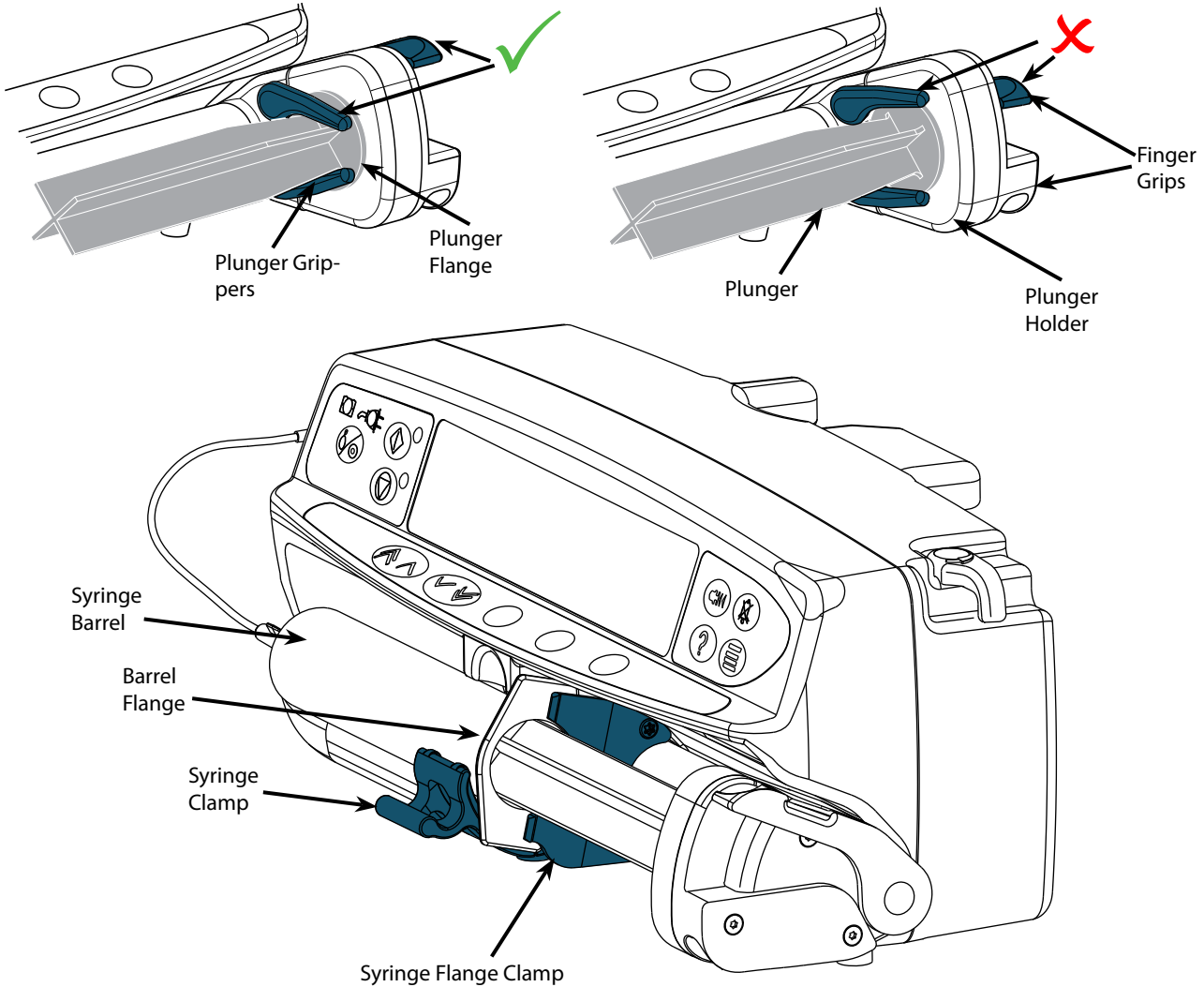

Place the pump on a stable horizontal surface or secure as described previously.

Prepare, load and prime the single-use disposable syringe and extension set using standard aseptic techniques.

1. Squeeze the finger grips together on the plunger holder and slide the mechanism to the right.
2. Pull the syringe clamp forward and down.



3. Insert the syringe ensuring that the barrel flange is located in the slots on the syringe flange clamp.



**To ensure the syringe is loaded correctly, place the barrel flange in the space between the syringe clamp and the syringe flange clamp. This is correct if the syringe remains in position before the syringe clamp is closed.**

4. Lift the syringe clamp until it locks against the syringe barrel.



5. Squeeze the finger grips on the plunger holder and slide the mechanism to the left until it reaches the plunger end.
6. Release the finger grips. Ensure that the plunger grippers are securing the plunger in place and the finger grip returns to its original position.



7. Ensure that the syringe type and size match those displayed on the pump then press **CONFIRM**. If required, the make of syringe can be changed by pressing the **TYPE** softkey.

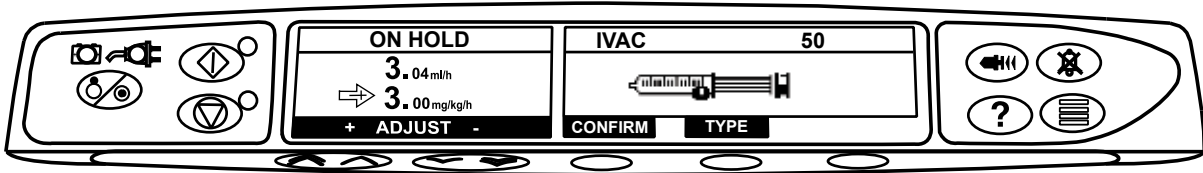

**Note:** If the **PURGE SYRINGE** option has been enabled then the prompt to purge screen is displayed and the extension set can be purged as required, however ensure that the extension set is not connected to the patient during this process.

**! CareFusion recommends limiting the number of configured syringe types and sizes available for selection on the pump.**

**Secure the extension set using the extension set hook at the rear of the pump. This provides protection against accidental dislodging of the syringe from the pump.**

**Ensure that both plunger grippers are fully locked onto the plunger flange and the upper finger grip has returned to its original position.**

## Getting Started (Continued)

### Starting the Pump

1. Connect the pump to an AC power supply using the AC power cable.

Press the  button.

- The pump will run a short self-test. Ensure that two beeps are activated during this test.
- Check the display test pattern and ensure that no rows are missing.
- Check that the displayed time and date are correct.
- Finally check display shows the Data Set name, Version number and Released date and time.

**Note:** A warning - **REPAIRING LOGS**, may be displayed if event log information was not completely stored at the previous power down. This is for information only, the pump will continue to power up as normal.

2. **CONFIRM PROFILE?** - Answering **NO** will display **SELECT PROFILE** screen, select profile and **OK**. **YES** will display **DRUG SELECT** screen. Go to step 3.

3. **DRUG SELECT?** - Select one of the following:

**ml/h** - allows infusions to be given in ml/h only, after selecting **OK** to confirm. Go to step 6.

**DOSING ONLY** - enables the pump to be set-up with a dosing protocol, after selecting **OK** to confirm. Go to step 4.

**Important Note: No drug-specific Guardrails® Limits are used when ml/h or DOSING ONLY modes are selected.**

**DRUG NAME** - select a drug name from Guardrails® Data Set profile, after selecting **OK** to confirm. Go to step 5.

**Note: Drugs are listed in alphabetical groups as follows: A-F, G-M, N-S and T-Z. Select group containing the drug name required and then the required drug and all other drugs can be seen.**

4. **DOSING ONLY** -

- a) Select Dosing unit and **OK** to confirm.
- b) Select Concentration Amount and **OK** to confirm. (Use **Units** softkey to change concentration units)
- c) Select Diluent Volume and **OK** to confirm.
- d) Adjust Weight and **OK** to confirm. (If required)
- e) Press **OK** to confirm dosing information. Go to step 6.

5. **DRUG NAME** -

- a) Select Concentration required and **OK** to confirm. (Only required if more than one concentration for Drug selected is available.)
- b) **OK** to confirm Concentration or **MODIFY** to change Drug amount and diluent volume. (**MODIFY** only available if concentration limits allow.)
- c) Adjust Weight and **OK** to confirm. (If required)
- d) Press **OK** to confirm setup. Go to step 6.

6. **LOAD SYRINGE** - Load the syringe according to the procedure in this manual.

7. **CONFIRM SYRINGE** - Check that the syringe type and size being used matches the display. If required, the make of syringe can be changed by pressing the **TYPE** button. Press **CONFIRM** when the correct type and size are shown.





**Note: If the PURGE SYRINGE option has been enabled then the prompt to purge screen is displayed and the extension set can be purged as required.**

8. **PURGE** (if required) - Press the  button and then press and hold the **PURGE** softkey until fluid flows and the purging of the extension set is complete. Release the softkey. The volume used during purging will be displayed.



## Getting Started (Continued)

### Starting the Pump (continued)

9. INFUSION RATE - Check the rate shown if set and change the rate if necessary using the   keys.
10. CONNECT TO PATIENT - Connect the extension set to the patient access device.
11. START - Press  to commence operation. **INFUSING** will be displayed. If the infusion settings are within the Guardrails® Soft Alerts then the AMBER STOP light will be replaced by the flashing GREEN START light to indicate that the pump is in operation.  
If infusion rate exceeds the Guardrails® Hard Limit then the pump will not start and the display will show **DOSE NOT PERMITTED**.  
If infusion rate exceeds or is under the Guardrails® Soft Alerts then check infusion setting, to continue with infusion at set rate press  and then confirm **OVERRIDE LIMIT** by pressing **YES**. If **OVERRIDE LIMIT** is not required press **NO** and adjust rate to be within the Guardrails® Soft Alerts.



**If infusion rate running exceeds or is under the Guardrails® Soft Alerts then the display will cycle between Drug Name, Profile name and Up or Down arrows.**

12. STOP - Press  to halt the operation. **ON HOLD** will be displayed. The AMBER STOP light will replace the GREEN START light.

## Basic Features



### Purge

The button allows the delivery of a limited volume of fluid in order to purge the extension set prior to being connected to a patient or after changing a syringe.

1. Press the button when the pump is not infusing. Ensure that the extension set is not connected to the patient.
2. Press and hold the **PURGE** softkey until fluid flows and the purging of the extension set is complete. The volume used during purging will be displayed, but it is not added to the volume infused.
3. When purging is complete release the **PURGE** softkey. Press the **QUIT** softkey to exit back to the main display.



**The pump will not purge if the "RATE LOCK" has been enabled. During PURGE the pressure limit alarms are temporarily increased to their maximum level.**



### Bolus Infusion

**Bolus** - Administering a controlled volume of fluid or drug at an increased rate for diagnostic or therapeutic purposes. The pump should always be infusing and always attached to the patient. (Drugs given by an IV bolus could achieve immediate and high drug concentration levels.)

Bolus can be used at the start of an infusion or during an infusion.

The bolus feature can be configured to:

- a) BOLUS Disabled
- b) BOLUS Enabled
  - i) Hands On only
  - ii) Hands On and Hands Free

#### **BOLUS Disabled**

If configured to *Disabled*, pressing the button will have no effect and the pump will continue to infuse at the set rate.



**A "Hands On" bolus and "Hands Free" bolus cannot be administered if the "RATE LOCK" is active or if the feature is disabled for the selected Profile or specific drug. During BOLUS the pressure limit alarm is temporarily increased to the maximum level.**

#### **BOLUS Enabled - Hands On**

In "Hands on" Bolus, press and hold the (flashing) **BOLUS** soft key to deliver the required bolus. The bolus rate can be adjusted. The bolus volume is limited in the configuration.

1. During infusion press the button once to display the bolus screen.
2. Use the keys to adjust the bolus rate if required.
3. To deliver the bolus press and hold the **BOLUS** softkey. During the bolus, the volume being infused is displayed. When the desired bolus volume has been delivered or the bolus volume limit is reached, release the softkey. The bolus volume is added to the total volume infused.

#### **BOLUS Enabled - Hands On and Hands Free**

The "Hands Free" Bolus is delivered with a single press of the (flashing) **BOLUS** soft key. The bolus rate and bolus volume are set by drug profile in the Data Set and can be changed within limits set by the Data Set.

1. During infusion press the button to display the "Hands Free" bolus selection screen.
2. Press the **YES** softkey to go to "Hands Free" selection bolus screen, press the **HANDS ON** softkey for "Hands On" bolus (see section above).
3. Use the keys to set the bolus volume/dose required; If necessary press the **RATE** softkey to adjust the bolus delivery rate (150/300/600/900/1200ml/h). **Note:** Rate may be restricted by the syringe size and the **CAP BOLUS RATE**.
4. Press the flashing **BOLUS** softkey once to begin the delivery of the preset bolus. The display will show the bolus being delivered, the bolus counting down and revert to main infusion display upon completion of the bolus.
5. To terminate a bolus being delivered press **STOP** softkey. This will stop the bolus and continue infusing at the set rate. Press the button to stop the bolus delivery and place the pump on hold.
6. If the bolus volume reaches the set bolus volume limit the bolus will stop and the pump will revert to infuse at the set infusion rate and continue infusing.



**If the "Hands Free" bolus option is active, then this feature will be cancelled following any interruption in delivery, e.g. occlusion, even if the bolus delivery is incomplete.  
If the volume to be infused (VTBI) is reached during a bolus, the VTBI complete alarm will sound. Press to silence the alarm or CANCEL to acknowledge the alarm. See VTBI section for more details on VTBI operation.  
Any "Hands Free" Bolus dose setting which exceeds or is under a Guardrails® Soft Alert must be confirmed before operation can be continued.**

#### **Manual Bolus**

The "Manual Bolus" is delivered by moving the plunger drive mechanism forward while the pump is infusing. This method of delivering a bolus is not recommended as best clinical practice.





The syringe must be confirmed and the plunger mechanism has to move from an engaged position to disengage and then re-engage position.

A minimum travel of 1mm (leadscrew pitch) must be detected to register.

## Basic Features (Continued)

### Volume to be Infused (VTBI)

This option allows you to set a specific volume to be infused. Rate at the end of this VTBI can also be set, selecting from stop, KVO, or continuous infusion at the set rate.

1. Press the **VTBI** softkey to select the volume to be infused option.
2. Enter the volume to be infused using the   keys and press the **OK** softkey.
3. Select the rate at the end of the VTBI using the   keys to scroll through the on-screen choices. The default is stop.
4. Press the **OK** softkey to enter the rate and exit the VTBI menu.

### Clear Volume

This option enables the volume infused to be cleared.

1. Press the **VOLUME** softkey to display the **CLEAR VOLUME** option.
2. Press the **YES** softkey to clear the volume. Press the **NO** softkey to retain the volume.

**Selecting YES resets the volume infused in the 24H LOG option.**

### Rate Lock



If Rate Lock is enabled, when the infusion rate has been set and the infusion started (or following a bolus infusion) the rate lock prompt will appear on the main display.

To select the rate lock function press the **YES** softkey. Press the **NO** softkey if the rate lock is not required.

**When rate lock is enabled, the following are unavailable:**

- **Changing the infusion rate / titration**
- **Bolus / purge**
- **Switching the pump off**
- **VTBI over time infusions.**

**To disable the rate lock if selected:**



1. Press the  button to access the options menu.
2. Select the **UNLOCK RATE** option using the   keys and press the **OK** softkey.

**To enable the rate lock if not selected:**





1. Press the  button to access the options menu.
2. Select **RATE LOCK** and press the **OK** softkey.

### Rate Titration



If Rate Titration is **enabled** the rate can be adjusted **while infusing**:

1. Select the new rate using the   keys.  
**The message < START TO CONFIRM > will flash on screen and pump continues to infuse at the original rate.**
2. Press the  button to confirm the new infusion rate and start infusing at the new rate. If the new infusion rate setting exceeds or is under a Guardrails® Soft Alert confirmation is required before infusion can start infusing at the new rate.

If Rate Titration is **disabled** the rate can only be adjusted **whilst on hold**:

1. Press the  button to put the pump on hold.
2. Select the new rate using the   keys.
3. Press the  button to start infusing at the new rate.

### Pressure Level

1. To check and adjust the pressure level press the  button. A bar graph will be displayed showing the pressure alarm level and the current pressure level.
2. Press the   keys to increase or decrease the alarm level. The new level will be indicated on the display.
3. Press **OK** to exit the screen.



**The interpretation of pressure readings and occlusion alarms are the responsibility of the clinician depending on the specific application.**

## Basic Features (Continued)

### ? Dosing Summary

To review currently selected dosing information:

1. Press the **?** button to first access the options menu.
2. Select **DOSING SUMMARY**.
3. Review the information and then press the **QUIT** softkey.

### ? Set VTBI over Time

This option allows you to specify a VTBI and delivery time. The rate necessary to deliver the required volume within the specified time is calculated and displayed.

1. Stop the infusion. Press the **?** button to access the options menu.
2. Select the **SET VTBI OVER TIME** option using the **↶↷** keys and press the **OK** softkey.
3. Adjust the volume to be infused using the **↶↷** keys. When the desired volume has been reached press the **OK** softkey.
4. Enter the time over which the volume is to be infused. The infusion rate will automatically be calculated. Press the **OK** softkey to enter the value.
5. Select the rate at VTBI end from the list using the **↶↷** keys and press the **OK** softkey. The default is STOP.

### ? 24 Hour Log

This option allows the 24 hour log of volume infused to be reviewed.

1. Press the **?** button to access the options menu.
2. Select the **24H LOG** option using the **↶↷** keys and press the **OK** softkey.

**The display shows the hourly volume infused. The volume infused shown in brackets is the total volume infused since the volume was last cleared. See example below:**

07:48 - 08:00 4.34ml (4.34ml)

08:00 - 09:00 2.10ml (6.44ml)

09:00 - 10:00 2.10ml (8.54ml)

**VOLUME CLEARED**

3. Press the **QUIT** softkey to exit the log.

### ? Event Log

This option allows the event log to be reviewed. It can be enabled/disabled.

1. Press the **?** button to access the options menu.
2. Select the **EVENT LOG** option using the **↶↷** keys and press the **OK** softkey.
3. Scroll through the log using the **↶↷** keys. Press the **QUIT** softkey to exit the log.

### ? Data Set Details

To review currently selected Data Set information:

1. Press the **?** button to access the options menu.
2. Select **DATA SET DETAILS**.
3. Review the information and then press the **QUIT** softkey.



### ? Infusion Setup

To change Infusion Setup

1. Press the **?** button to access the options menu.
2. Select **INFUSION SETUP**.
3. Select Infusion Setup required and press the **OK** softkey.







## Alarms and Warnings

Alarms are indicated by a combination of an audible alarm, flashing alarm indicator and a descriptive message in the display (except DOSE WOULD EXCEED, DOSE UNDER & DOSE NOT PERMITTED which only have an audible alarm and message).

1. First press the  button to silence the alarm for a maximum of 2 minutes\*, then check the display for an alarm message. Press **CANCEL** to cancel the alarm message.
2. If the infusion has stopped, rectify the cause of the alarm then press the  button to resume the infusion.



**If the pump initiates a safety processor alarm condition (an audible high pitched continuous shrill accompanied with a red alarm indicator) and there is no error message displayed on the pump, remove the pump from service for examination by a qualified service engineer.**

<i>Display</i>	<i>Description and Troubleshooting Guide</i>
<b>DRIVE DISENGAGED</b>	The drive system has been disengaged during operation. Check the finger grips and the position of the syringe.
<b>OCCCLUSION</b>	Excessive pressure measured at the syringe plunger exceeding the alarm limit. Identify and remove the cause of the blockage in the drive, syringe, or administration system before restarting the infusion.
<b>CHECK SYRINGE</b>	<p>Incorrect size of syringe has been fitted, the syringe has not been positioned correctly or has been disturbed during operation. Check the syringe location and the position.</p> <p>A <b>CHECK SYRINGE</b> alarm may indicate the incorrect size of syringe has been fitted; the syringe has not been positioned correctly, or has been disturbed during operation, for example, the user opens the syringe clamp, or if the syringe plunger loses contact with the plunger button.</p> <p>If there is no identifiable cause for the <b>CHECK SYRINGE</b> alarm(s) then the pump should be removed from clinical use and examined by Qualified Service Personnel in accordance with the Alaris Syringe Pump Technical Service Manual.</p>
<b>BATTERY LOW</b>	Battery charge low with 30 minutes operation remaining. Battery indicator will flash and after 30 minutes a continuous audible alarm will indicate that the battery is exhausted. Reconnect to the AC power supply to continue operation and charge the internal battery.
<b>BATTERY EMPTY</b>	The internal battery is exhausted. Connect the pump to the AC power supply.
<b>NEAR END OF INFUSION</b>	The pump is nearing the end of the infusion. This value can be configured.
<b>END OF INFUSION</b>	The pump has reached the end of the infusion. A pre-set volume will remain in the syringe to minimise the risk of the infusion of air bubbles into the set. This value can be configured.
<b>TITRATION NOT CONFIRMED</b>	The infusion rate has been changed, but has not been confirmed and 2 minutes has expired without any operation. Press the  button to silence the alarm, then press the <b>CANCEL</b> softkey to clear this message and silence the alarm. Check infusion rate and confirm by pressing the  button or press the  button to revert to the previous rate. Press the  button to start infusion. (This alarm only occurs if rate titration is enabled).
<b>VTBI DONE</b>	The pre-set Volume To Be Infused is complete.
<b>AC POWER FAIL</b>	AC Power has been disconnected and the pump is operating on battery power, if this occurs when the pump is infusing the message " <b>INFUSION CONTINUES</b> " will be displayed. Reconnect AC power supply or press the  button to silence the alarm and continue with battery operation. The alarm will automatically cancel if the AC power supply is reconnected.
<b>Error Code and Message</b>	The alarm system has detected an internal malfunction. Note the malfunction code. Remove pump from service for examination by a qualified service engineer.
<b>ATTENTION (with "3 Beeps")</b>	Three beeps will sound if the pump has been left ON for more than 2 minutes* (referred to as <b>CALLBACK</b> in the log) without starting the operation. Press the  button to silence the alarm for a further 2 minutes*. Alternatively press and hold down the  button and wait for 3 beeps in succession, this will put the warning alarm on standby for 15 minutes.
<b>Alarm Indicator Colour</b>	<b>Alarms indicated</b>
<b>AMBER</b>	AC POWER FAIL; NEAR END OF INFUSION; VTBI DONE (KVO or CONTINUE), ATTENTION; TITRATION NOT CONFIRMED; BATTERY LOW.
<b>RED</b>	All others.

\*Configurable option.

## Prompts

<i>Display</i>	<i>Description and Troubleshooting Guide</i>
<b>DOSE WOULD EXCEED</b>	The infusion rate has been set to a value which exceeds a Guardrails® Soft Alert. Check infusion setting, to continue with infusion at set rate confirm <b>OVERRIDE LIMIT</b> by pressing the <b>YES</b> softkey. If <b>OVERRIDE LIMIT</b> is not required press the <b>NO</b> softkey and adjust rate below Guardrails® Soft Alert.
<b>DOSE UNDER</b>	The infusion rate has been set to a value which is under a Guardrails® Soft Alert. Check infusion setting, to continue with infusion at set rate confirm <b>OVERRIDE LIMIT</b> by pressing the <b>YES</b> softkey. If <b>OVERRIDE LIMIT</b> is not required press the <b>NO</b> softkey and adjust rate above Guardrails® Soft Alert.
<b>DOSE NOT PERMITTED</b>	The infusion rate has been set above a Guardrails® Hard Limit. Check infusion setting and adjust rate to appropriate required rate.
<b>BOLUS DOSE OVER</b>	The bolus dose has been set to a value which exceeds a Guardrails® Soft Alert. Check the bolus setting, to continue with the bolus confirm <b>OVERRIDE LIMIT</b> by pressing the <b>YES</b> softkey. If <b>OVERRIDE LIMIT</b> is not required press the <b>NO</b> softkey and adjust dose below Guardrails® Soft Alert.
<b>BOLUS DOSE UNDER</b>	The bolus dose has been set to a value which is under a Guardrails® Soft Alert. Check the bolus setting, to continue with the bolus confirm <b>OVERRIDE LIMIT</b> by pressing the <b>YES</b> softkey. If <b>OVERRIDE LIMIT</b> is not required press the <b>NO</b> softkey and adjust dose above Guardrails® Soft Alert.
<b>BOLUS DOSE NOT PERMITTED</b>	The bolus dose has been set above a Guardrails® Hard Limit. Check bolus setting and adjust to appropriate required dose.
<b>CONCENTRATION NOT PERMITTED</b>	The drug concentration has been set above or below a Guardrails® Hard Limit. Check the amount and diluent volume and adjust to give the appropriate required concentration.
<b>WEIGHT OUTSIDE LIMIT</b>	The patient weight has been set to a value which exceeds or is under a Guardrails® Soft Alert. Check the weight setting, to continue confirm <b>OVERRIDE LIMIT</b> by pressing the <b>YES</b> softkey. If <b>OVERRIDE LIMIT</b> is not required press the <b>NO</b> softkey and adjust the value within the limits.
<b>RATE NOT PERMITTED</b>	The infusion rate has been set above a Guardrails® Hard Limit. Check infusion setting and adjust to appropriate required rate.

## Configured Options





This section comprises of a list of options which are configurable. Some can be entered via the pump configuration menu (available in Technician Mode) and others through the Guardrails® Editor Software.

Enter the access code on Alaris® GH Guardrails® Syringe Pump for Configured Options, see the Technical Service Manual for details.

**Important: Access codes should only be entered by qualified technical personnel.**





Use Guardrails® Editor to configure general options, drug library and units enabled for each profile and to configure Syringe Brands and Models to be enabled.

### Clock Set

1. Select **CLOCK SET** from the Configured Options menu using the   keys and press the **OK** softkey.
2. Use the   keys to adjust the date displayed, pressing the **NEXT** softkey to access the next field.
3. When the correct time and date are displayed press the **OK** softkey to return to the Configured Options menu.





### Language

This option is used to set the language of messages shown on the pump display.



1. Select **LANGUAGE** from the Configured Options menu using the   keys and press the **OK** softkey.
2. Use the   keys to select the language.
3. When the desired language has been selected press **SELECT** softkey to return to the Configured Options menu.

### Contrast

This option is used to set the contrast on the pump display.

1. Select **CONTRAST** from the Configured Options menu using the   keys and press the **OK** softkey.
2. Use the   keys to select a contrast ratio value. The contrast of the display will change when scrolling through the numbers.
3. When the desired value has been reached press the **OK** softkey to return to the Configured Options menu.

### Alaris® GH Guardrails® Syringe Pump General Options

1. Select **GENERAL OPTIONS** from the Configured Options menu using the   keys and press the **OK** softkey.
2. Select the option you wish to enable/disable or adjust and press the **MODIFY** softkey.
3. When all the desired modifications have been carried out press the **QUIT** softkey.
4. Either select the next configuration option from the menu or turn the pump **OFF**, returning it to operation as required.

<b>NURSE CALL FITTED</b>	Enables Nurse Call (hardware option).
<b>NURSE CALL INVERT</b>	When enabled, the nurse call output is inverted.
<b>RS232 SELECTED</b>	Sets the pump's communications to use RS232 (hardware option).

## Configured Options (Continued)

### Guardrails® Editor Software Profile Configuration

The following options are only configurable via the Guardrails® Editor Software (PC based), see Guardrails® Editor Directions For Use (1000PB01398) for details on how to configure Profile Configurations.

<b>Quiet Mode</b>	Mode to silence key press tones and power down sequence.
<b>Audio Volume</b>	The audio alarm volume of the pump (high, medium or low).
<b>Auto Night Mode</b>	Main Display (Backlight) dims between hours 21:00 and 06:00.
<b>AC Fail</b>	The AC Power Failure Alarm can be set to sound or be silent if the AC power is disconnected.
<b>Auto Save</b>	Feature to retain previous settings when pump is switched on.
<b>Event Log</b>	The event log can be set to be displayed or not on main display. Events still recorded in event log if disabled.
<b>Battery Icon</b>	Indicator displaying the remaining estimated battery capacity.
<b>Callback Time</b>	Adjusts the length of time before the pump sounds the call back alarm.
<b>Drug Override Mode</b>	<i>Always</i> - Any changes made to the dose rate that are outside of the Guardrails® Soft Alerts will require confirmation before starting infusion.  <i>Smart</i> - Confirmation of setting will be required on first dose rate set outside of the Guardrails® Soft Alert. Any subsequent changes will not require confirmation until after the dose rate has been confirmed inside the Guardrails® Soft Alert limits. Additionally any changes in dose rate from above a Soft Alert Max to below a Soft Alert Min or from below a Soft Alert Min to above a Soft Alert Max will also need to be confirmed.
<b>Maximum Pressure</b>	The maximum occlusion pressure alarm level that can be selected during an infusion.
<b>Back Off</b>	An automatic feature which is activated following an occlusion. The pump action reverses and pumps backwards to release the pressure which has built up in the infusion system, this minimises the post occlusion bolus.
<b>Pressure Display</b>	Sets whether the Pressure Information is available on the main display.
<b>Default Weight</b>	The default patient weight in kg.
<b>Maximum Weight</b>	The maximum patient weight in kg. This is a Guardrails® Soft Alert and can be overridden.
<b>Minimum Weight</b>	The minimum patient weight in kg. This is a Guardrails® Soft Alert and can be overridden.
<b>Rate Lock</b>	Anti-tamper feature which prevents rate changes, bolus operations and powering pump down.
<b>Rate Titration</b>	Feature to adjust the infusion rate while the pump is infusing, without putting the pump on hold
<b>Cap Rate</b>	The maximum value for infusion rate.
<b>Cap Bolus Rate</b>	The maximum value for bolus rate.
<b>Purge Rate</b>	The rate used during purge operation.
<b>Purge Volume Limit</b>	The maximum permissible purge volume.
<b>Purge Syringe</b>	Feature which prompts the user to purge the extension set prior to the start of the infusion.
<b>Manual Bolus</b>	Bolus delivered by manually moving the plunger mechanism during an infusion or while on hold. Volume infused displayed will be increased accordingly.
<b>KVO</b>	Sets the Keep Vein Open (KVO) rate at which the pump will operate when End of Infusion (EOI) is reached. Also allows KVO at EOI to be disabled.
<b>Near End of Infusion Point</b>	Sets the Near End Of Infusion warning time, as time left to End Of Infusion.
<b>End of Infusion %</b>	Sets the End Of Infusion point, as a percentage of syringe volume.
<b>VTBI Clear Rate</b>	Infusion rate will be set to zero when VTBI has been completed.



## Configured Options (Continued)

### Guardrails® Editor Software Profile Configuration (Continued)

The following configurations are only used when the Alaris® GH Guardrails® Syringe Pump is being used in ml/h or Dosing Only modes. (If a drug is selected then the drug's own configuration settings are used.)

<b>Bolus</b>	Bolus feature can be set to <i>OFF</i> , <i>HANDS ON</i> or <i>HANDS ON &amp; HANDS FREE</i> .
<b>Default Bolus Rate</b>	The default value for bolus rates.
<b>Max Bolus Volume</b>	The maximum permissible bolus volume.
<b>Occlusion Alarm Pressure</b>	The default occlusion pressure alarm level.
<b>Units Enabled for Dosing Only</b>	Dosing only mode on an Alaris® Syringe Pump allows the pump to be set-up with a dosing protocol with no drug selected. Only the dosing units selected in Units Enabled for Dosing Only will be available for selection when the Alaris® Syringe Pump is in Dosing Only mode.



The approved Data Set contains configurable option values per profile.

The originator and approvers of the Data Set should be aware that, unless a rationale for safety is provided, it is not recommended to set the callback time to a value greater than the default setting of 2 minutes since doing so would not be in compliance with EN60601-2-24:1998 standard.

### Guardrails® Editor Software Profile Drug library

The following drug parameters are only configurable via the Guardrails® Editor Software (PC Based), see Guardrails® Editor Directions For Use (1000PB01398) for details on how to configure Profile Drug Library, and are used when the Alaris® GH Guardrails® Syringe Pump is being used with a drug name selected.

<b>Concentration Limits (Min &amp; Max)</b>	These define the range over which the drug concentration can be modified during programming of the Alaris® GH Guardrails® Syringe Pump.
<b>Continuous Dose Rate -</b>	
<b>Units</b>	The continuous dose rate units. Can be based on patient weight.
<b>Hard Limit Max</b>	The maximum allowed continuous dose rate.
<b>Soft Alert Max</b>	The continuous dose rate value above which override confirmation is required.
<b>Soft Alert Min</b>	The continuous dose rate value below which override confirmation is required.
<b>Default</b>	The default continuous dose rate offered when the drug is selected.
<b>Bolus</b>	Bolus feature can be set to <i>OFF</i> , <i>HANDS ON</i> or <i>HANDS ON &amp; HANDS FREE</i> .
<b>Bolus Dose -</b>	
<b>Units</b>	The bolus dose units. Can be based on patient weight.
<b>Hard Limit Max</b>	The maximum allowed bolus dose.
<b>Soft Alert Max (HANDS FREE only)</b>	The bolus dose value above which override confirmation is required.
<b>Soft Alert Min (HANDS FREE only)</b>	The bolus dose value below which override confirmation is required.
<b>Default (HANDS FREE only)</b>	The default bolus dose offered.
<b>Bolus Rate -</b>	
<b>Default</b>	The default value for bolus rate in ml/h.
<b>Occlusion Alarm Pressure</b>	The default occlusion alarm pressure level.

## Specifications

### Infusion Specifications -

Maximum infusion rate can be set as part of the configuration.

0.1ml/h - 150ml/h	5ml syringes
0.1ml/h - 300ml/h	10ml syringes
0.1ml/h - 600ml/h	20ml syringes
0.1ml/h - 900ml/h	30ml syringes
0.1ml/h - 1200ml/h	50ml syringes

The Volume Infused range is 0.0ml - 9990ml.

### Bolus Specifications -

Maximum Bolus rates can be set as part of the configuration. Bolus rates are user adjustable, in increments of 10ml/h.

10 ml/h - 150ml/h	5ml syringes
10 ml/h - 300ml/h	10ml syringes
10 ml/h - 600ml/h	20ml syringes
10 ml/h - 900ml/h	30ml syringes
10 ml/h - 1200ml/h	50ml syringes

The bolus volume limit can be set as part of the configuration.

Minimum: 0.5ml; maximum 25.0ml

Increments of 0.1ml; default 5.0ml

During BOLUS the pressure limit alarms are temporarily increased to their maximum level.

### Critical Volume -

The bolus which can occur in the event of a single internal fault condition with a 50 ml syringe is :

Maximum Overinfusion - 0.87ml

### Purge Specifications -

The purge rate is limited to the maximum rate for the syringe and can be set as part of the configuration.

100ml/h - 500ml/h.

The purge volume range is 0.5ml - 5ml.

During PURGE the pressure limit alarms are temporarily increased to their maximum level.

### Keep Vein Open (KVO) Rate -

0.1 ml/h - 2.5ml/h.

### End Of Syringe Rate -

Stop, KVO (0.1ml/h to 2.5ml/h), or set rate if lower than KVO.

### Volume To Be Infused (VTBI) -

0.1ml - 100ml, 1min - 24h

### VTBI Complete Rate -

Stop, KVO (0.1ml/h to 2.5ml/h), set rate if lower than KVO or continue at set rate.

### Near End Of Infusion Alarm -

1min - 15min to end of infusion, or 10% of syringe volume, whichever is smaller.

### End Of Infusion (EOI) Alarm -

0.1% - 5% of syringe volume

### Electrical Classification -

Class I product. Continuous Mode Operation, Transportable

### Maximum Pumping Pressure Limit -

Highest alarm level 1000mmHg (nominal at L-10)

### Occlusion Accuracy (% of full scale)\* -

	Pressure mmHg			
	L-0	L-3	L-5	L-10
	approx. 50 mmHg	approx. 300 mmHg	approx. 500 mmHg	approx. 1000 mmHg
Temp. 23°C	±18%	±21%	±23%	±28%

\* - Using most common 50ml syringes under normal conditions (95% confidence / 95% of pumps).

### System Accuracy -

Volumetric Mean +/- 2% (nominal).

Derating -

Temperature +/- 0.5% (5 - 40°C)

High Rates +/-2.0% (rates > syringe volume/h eg. >50ml/h in a 50ml syringe.)

**Important: System accuracy is +/-2% typical by volume as measured using the trumpet curve test method defined in EN/IEC60601-2-24 at rates of 1.0ml/h (23°C) and above when the pump is used with the recommended syringes. Caution: Infusion volume accuracy may be compromised at rates below 1.0ml/h. Differences in factors such as size and plunger force in compatible syringes can cause variations in accuracy and trumpet curves. See also trumpet curves section in this manual.**

### Guardrails® Data Set Specification -

A maximum of 10 profiles can be set with a maximum of 100 drugs per profile. See Guardrails® Editor Software DFU for more details.

### Battery Specifications -

Rechargeable sealed NiMH. Automatically charges when the pump is connected to AC power.

Mean Time To Battery Empty from fully charged @ 5ml/h & 20°C under normal conditions is 6 hours\*

\*95% lower confidence interval of 5 hours 50 minutes

Charging takes 2½ hours from discharge to 90% charge.

### Memory Retention -

The electronic memory of the pump will be retained for more than 6 months when not powered up.

### Fuse Type -

2 x T 1.25A, slow blowing.

### AC Power Supply -

115 - 230VAC, 50 - 60Hz, 20VA (nominal).

### Dimensions -

310 mm (w) x 121 mm (h) x 200 mm (d). Weight: 2.7 kg (excluding power cable).

### Protection against fluid ingress -

IPX1 - Protected against vertically falling drops of water.

### Alarm Conditions -

Drive Disengaged	Occlusion
Check Syringe	Battery Low / Battery Empty
Near End Of Infusion	End of Infusion
VTBI Done	AC Power Fail
Internal Malfunction	Attention (Nurse Callback)
Titration not confirmed	Dose Would Exceed
Dose not Permitted	Dose Under
Bolus Dose Under	Bolus Dose not Permitted
Concentration not Permitted	Weight Outside Limit
Rate not Permitted	Bolus Dose Over

### Environmental Specifications -

Operating Temperature	<b>+5°C - +40°C</b>
Operating Relative Humidity	<b>20% - 90%</b>
Operating Atmospheric Pressure	<b>700hPa - 1060hPa</b>
Transport & Storage Temperature	<b>-30°C - +50°C</b>
Transport & Storage Relative Humidity	<b>10% - 95%</b>
Transport & Storage Atmospheric Pressure	<b>500hPa - 1060hPa</b>

### Electrical/Mechanical Safety -

Complies with EN/IEC60601-1 and EN/IEC60601-2-24.

### EMC -

Complies with EN/IEC60601-1-2 and EN/IEC60601-2-24.

## Recognised Syringes

The pump is calibrated and labelled for use with single-use disposable Luer-lock syringes. Only use the size and type of syringe specified on the pump display. The full list of permitted syringe models is dependent on the software version of the pump.

	5ml	10ml	20ml	30ml	50ml
IVAC®					✓
AstraZeneca					✓
B Braun Omnifix	✓	✓	✓	✓	✓
B Braun Perfusor			✓		✓
BD Perfusor					✓
BD Plastipak	✓	✓	✓	✓	✓
BD Precise			✓		✓
Codan		✓	✓	✓	✓
Codan Perfusion					✓
Fresenius Injectomat		✓			✓
Monoject**	✓	✓	✓	✓	✓
Pentaferte	✓	✓	✓		✓
Rapiject*					✓
Terumo	✓	✓	✓	✓	✓

\* - The Rapiject 50ml syringe is a specialised syringe with a large diameter barrel. To provide protection against accidental dislodging always ensure the extension set is secured using the extension set hook - see Loading a Syringe section.

\*\* - ≡ TYCO / Healthcare KENDALL - MONOJECT.



**To minimise the risk of incorrect confirmation of the syringe type it is recommended that only syringe types available in the hospital are configured on the pump.**



**CareFusion has characterized a range of syringes as identified in the 'Recognised Syringes' table. CareFusion cannot guarantee the continued system accuracy of these recognised syringes\* as the manufacturer may change syringe specification significant to system accuracy without prior notification.**

**Subject to the above, BD branded luer lock syringes can be confirmed as BD Plastipak syringes due to there being no significant variance in dimensions.**

**In no event shall CareFusion be liable for any damages of any kind or nature, including without limitation, direct or indirect, special, consequential, or incidental damages arising from, or in connection with the use of syringes not listed in the 'Recognised Syringes' table.**

## Associated Products

The Alaris® DS Docking Station

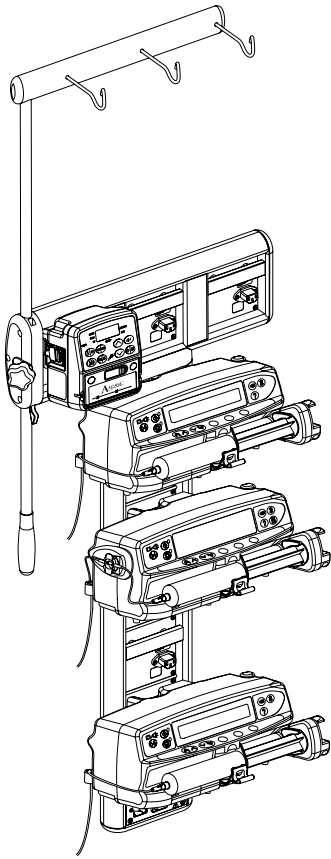

The Alaris® Gateway Workstation

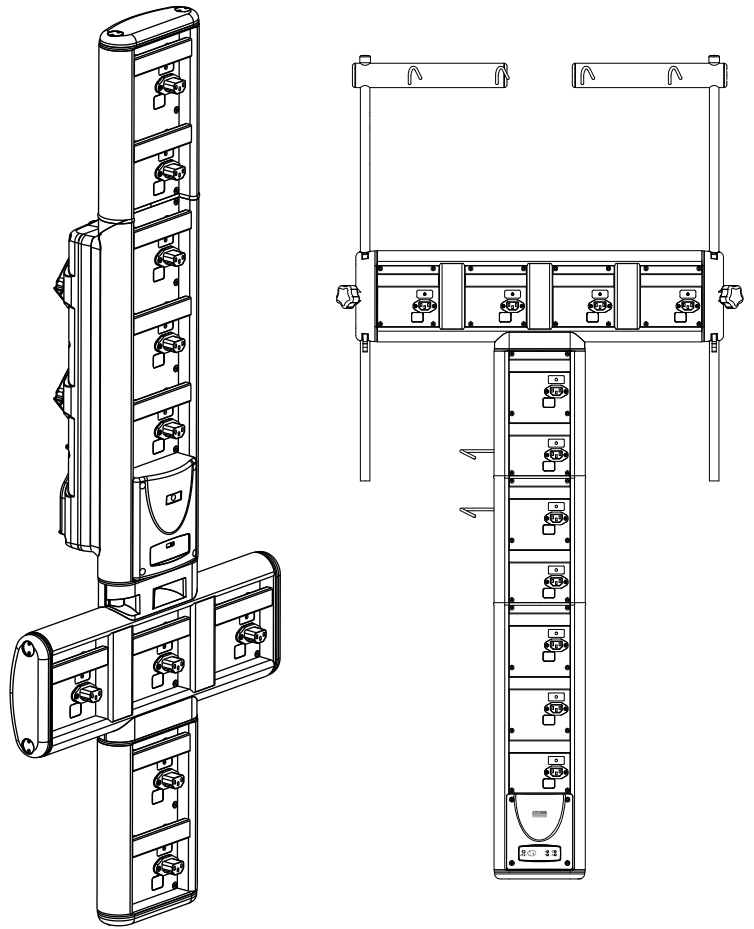

## Compatible Extension Sets

The pump uses standard, single-use, disposable extension sets and syringes with Luer-lock connectors. The user is responsible for verifying the suitability of a product used, if it is not recommended by CareFusion.

### Standard Sets

**G40015** Standard PVC Syringe Extension Set (150 cm).  
Priming Volume: 2.6ml

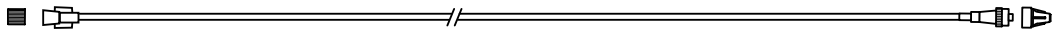

**G40020B** Standard PVC Syringe Extension Set (200 cm).  
Priming Volume: 1.5ml

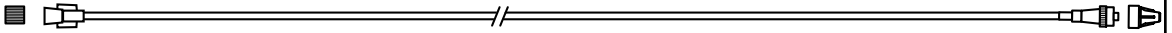

**G402EP** Extension set, Luer lock connectors. Kink resistant DEHP free PVC yellow striped tubing. Bore 1mm. Length 200cm.  
Priming volume 1.6ml.

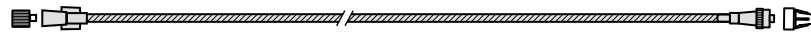

### Low Sorbing Sets

**G40615** Polyethylene Syringe Extension Set (150 cm).  
Priming Volume: 1.5ml

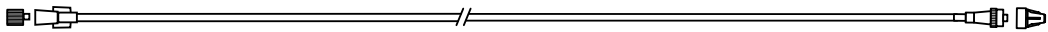

**G40620** Polyethylene Syringe Extension Set (200 cm).  
Priming Volume: 2ml

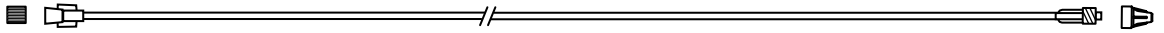

**G40720** Polyethylene Lined Syringe Extension Set with clamp. (200 cm).  
Priming Volume: 1.5ml

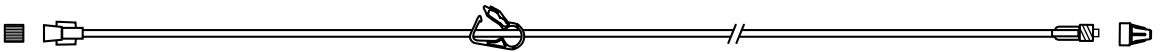

**04105010509** Polyethylene Syringe Extension Set (100 cm).  
Priming Volume: 1ml



### Light Protected Sets

**G40215** Amber PE Syringe Extension Set (150 cm).  
Priming Volume: 1.2ml

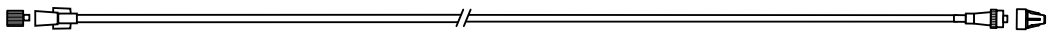

**G40320** White PVC Syringe Extension Set (200 cm).  
Priming Volume: 3.6ml

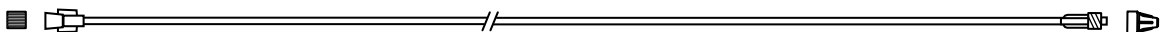

**For availability please contact your local CareFusion representative because new sets are continuously being developed for our customers.**

It is recommended that extension sets are changed in accordance with the Directions for Use.  
Carefully read the Directions For Use supplied with the extension set prior to use.

*Please note these drawings are not to scale*

## Compatible Extension Sets (Continued)

The pump uses standard, single-use, disposable extension sets and syringes with Luer-lock connectors. The user is responsible for verifying the suitability of a product used, if it is not recommended by CareFusion.

### Patient Controlled Analgesia (PCA) Sets

**30822** PVC Syringe Extension Set with clamp (152 cm).  
Priming Volume: 0.5ml



**30832** PVC 'Y' Syringe Extension Set with back check valve and 2 clamps (178 cm).  
Priming Volume: 1.5ml

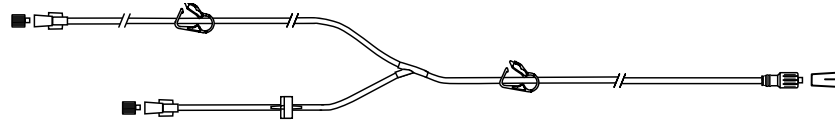

**30842E** PVC Syringe Extension Set with back check valve, SmartSite® Needle-Free Valve Port and clamp (30 cm).  
Priming Volume: 1.4ml

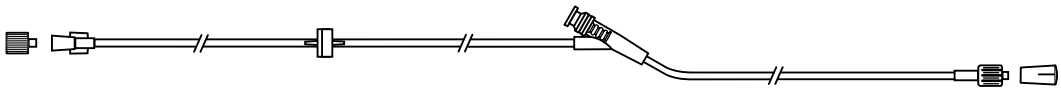

**30852** PVC 'Y' Syringe Extension Set with anti-siphon valve, back check valve and 2 clamps (183 cm).  
Priming Volume: 1.8ml

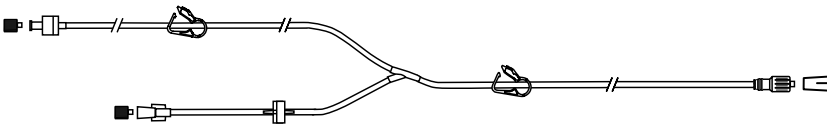

**30862** PVC Syringe Extension Set with anti-siphon valve and clamp (156 cm).  
Priming Volume: 0.6ml

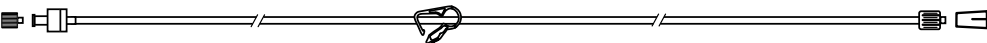

**04102215162** PVC Syringe Extension Set with rotating luer. (150 cm).  
Priming Volume: 2.9ml

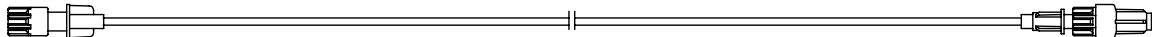

**04100010162** PVC Syringe Extension Set (105 cm).  
Priming Volume: 7.2ml

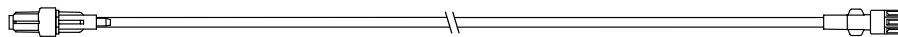

**For availability please contact your local CareFusion representative because new sets are continuously being developed for our customers.**

It is recommended that extension sets are changed in accordance with the Directions for Use.  
Carefully read the Directions For Use supplied with the extension set prior to use.

*Please note these drawings are not to scale*

## Maintenance

### Routine Maintenance Procedures

To ensure that this pump remains in good operating condition, it is important to keep it clean and carry out the routine maintenance procedures described below.

<b>Interval</b>	<b>Routine Maintenance Procedure</b>
<b>As per Hospital Policy</b>	Thoroughly clean external surfaces of the pump before and after prolonged period of storage.
<b>Each usage</b>	<ol style="list-style-type: none"><li>1. Inspect AC power supply plug and cable for damage.</li><li>2. Inspect case, keypad and plunger for damage.</li><li>3. Check Start up self test operation is correct.</li></ol>
<b>Before the transfer of the pump to a new patient and as required</b>	Clean the pump by wiping over with a lint-free cloth lightly dampened with warm water and a standard disinfectant / detergent solution.



**If the pump is dropped, damaged, subjected to excessive moisture or high temperature, immediately take it out of service for examination by a qualified service engineer.**

**All preventative and corrective maintenance and all such activities shall be performed at a compliant work place in accordance with the information supplied. CareFusion will not be responsible should any of these actions be performed outside the instructions or information supplied by CareFusion. For Preventative and Corrective Maintenance instructions please refer to the Technical Service Manual (TSM).**

**All servicing should only be performed by a qualified service engineer with reference to the TSM.**



**Please refer to Technical Service Manual for calibration procedures. The units of measurement used in the calibration procedure are standard SI (The International System of Units) units.**

### Battery Operation

The internal rechargeable battery allows continued operation when the AC power is unavailable, for example during patient transfer or AC power failure. Mean Time To Battery Empty from fully charged @ 5ml/h & 20°C under normal conditions is 6 hours\*. From the battery low alarm it will take about 2½ hours to 90% charge when reconnected to the AC power supply, whether the pump is in use or not.

The battery is maintenance free, sealed Nickel Metal Hydride and requires no routine servicing. However, to achieve optimum operation, ensure that the battery is fully recharged after full discharge, before storage, and at regular 3 month intervals during storage.

It is recommended that only a qualified service engineer replaces the battery. For further information regarding the replacement of batteries refer to the Technical Service Manual.

The battery pack used in this Alaris® Syringe Pump is manufactured by CareFusion and includes a proprietary PCB (printed circuit board) designed specifically for the Alaris® Syringe Pump, and in conjunction with Alaris® Syringe Pump software, controls battery use, charge and temperature. Any use of battery packs that are not manufactured by CareFusion in the Alaris® Syringe Pump is at your sole risk, and CareFusion does not provide any warranty for or endorsement on any battery packs that are not manufactured by CareFusion. CareFusion's product warranty shall not apply in the event the Alaris® Syringe Pump has suffered damage or premature wear, or malfunctions or otherwise operates incorrectly, as a result of use with a battery pack that is not manufactured by CareFusion.

\*95% lower confidence interval of 5 hours 50 minutes

## Maintenance (continued)

### Cleaning and Storage

Before the transfer of the pump to a new patient and periodically during the use, clean the pump by wiping over with a lint-free cloth lightly dampened with warm water and a standard disinfectant / detergent solution.

Do not use the following disinfectant types:

- Disinfectants which are known to be corrosive to metals must not be used, these include:
- NaDcc (such as Presept),
- Hypochlorites (such as Chlorasol),
- Aldehydes (such as Cidex),
- Cationic Surfactants >1% (such as Benzalkonium Chloride).
- Mixture of Alcohol & Chemicals with Cationic surfactants >1% Chlorohydrocarbons (such as Amberclens)
- Use of Iodine (such as Betadine) will cause surface discoloration.
- Concentrated Isopropyl alcohol based cleaners will degrade plastic parts.

Recommended cleaners are:

Brand	Concentration
Hibiscrub	20% (v/v)
Virkon	1% (w/v)

The following products were tested and are acceptable for use on the Alaris Enteral Plus Syringe Pump if used in accordance with the specified manufacturer's guidelines.

- Warm soapy water
- Mild detergent in water (e.g. Young's Hospec)
- 40% Isopropyl Alcohol in water
- Chlor-Clean
- Clinell Universal Wipes
- Hibiscrub
- Tristel Fuse sachets
- Tristel Trio wipes system
- Tuffie 5 wipe
- Virkon Disinfectant

The syringe and extension sets are disposable single use items and should be discarded after use according to their manufacturers' instructions.

If the pump is to be stored for an extended period it should be first cleaned and the internal battery fully charged. Store in a clean, dry atmosphere at room temperature and, if available, employ the original packaging for protection.

Once every 3 months during storage, carry out functional tests as described in the Technical Service Manual and ensure that the internal battery is fully charged.



**Before cleaning always switch OFF and disconnect from the AC power supply. Never allow liquid to enter the casing and avoid excess fluid build up on the pump. Do not use aggressive cleaning agents as these may damage the exterior surface of the pump. Do not steam autoclave, ethylene oxide sterilise or immerse this pump in any fluid.**



## Disposal

### Information on Disposal for Users of Waste Electrical & Electronic Equipment

This  symbol on the product and/or accompanying documents means that used electrical and electronic products should not be mixed with household waste.

If you wish to discard electrical and electronic equipment, please contact your CareFusion affiliate office or distributor for further information.

Disposing of this product correctly will help to save valuable resources and prevent any potential negative effects on human health and the environment which could otherwise arise from inappropriate waste handling.

### Information on Disposal in Countries outside the European Union

This symbol is only valid in the European Union. The product should be disposed of taking environmental factors into consideration. To ensure no risk or hazard, remove the internal rechargeable battery and the Nickel Metal Hydride battery from the control board and dispose of as outlined by the local country regulations. All other components can be safely disposed of as per local regulations.

## Occlusion Pressure Limits

Time to alarm following occlusion is achieved in less than 30 minutes at rates of 1 ml/h and higher by the appropriate selection of occlusion levels.

The following graphs show the typical values for time to alarm and bolus volume that can be expected in the event of an occlusion when the BD Plastipak 50 ml syringe is selected with a G40020B standard extension set.

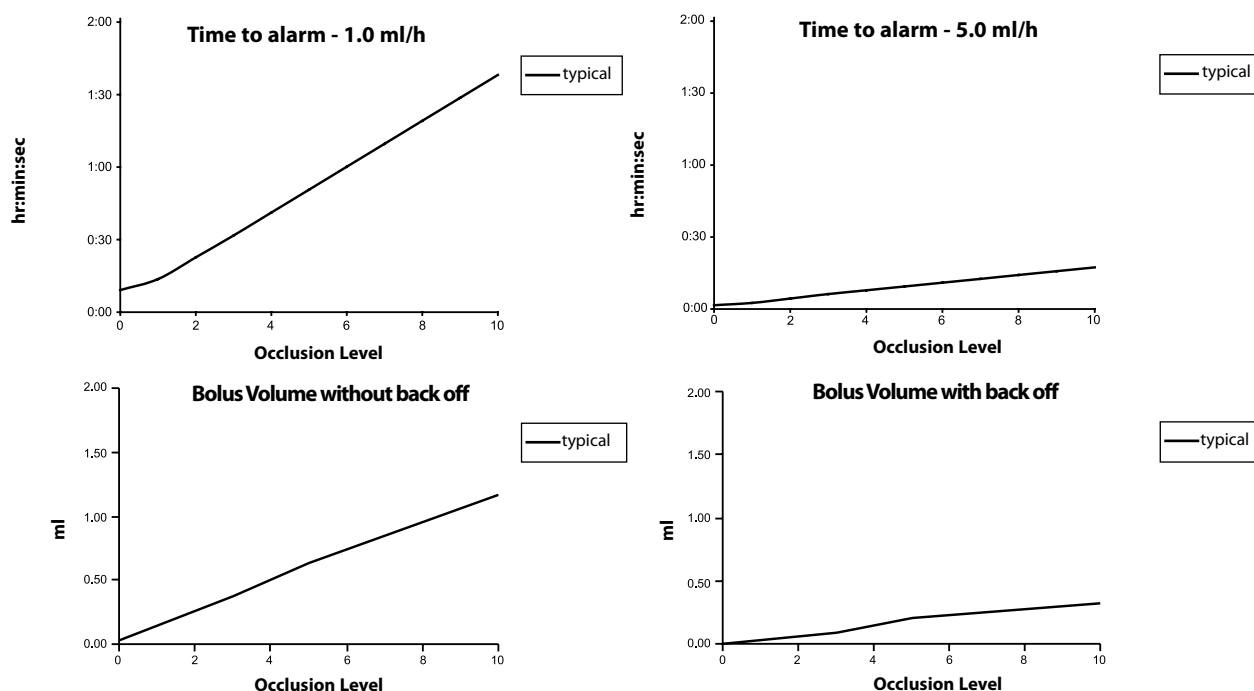

Tests at low alarm levels may alarm immediately - the force at these levels is commonly less than the friction in the syringe (with no additional fluid pressure). The result is that the pressure relating to the low forces will be less than the nominal quoted occlusion pressure.

Bolus volume following occlusion will be minimised by the back off feature if enabled. The back off will reduce the line pressure by removing the volume stored in the occluded line and deducting this volume from the volume infused.

# IrDA, RS232 and Nurse call Specification

## IrDA / RS232 / Nurse call Feature

The IrDA (or RS232 / Nurse call optional feature) is a feature on Alaris® Syringe Pumps that allows the pump to be connected to a PC or other Alaris® Syringe Pumps. This allows data to be transferred between the Alaris® Syringe Pump and a PC or another Alaris® Syringe Pump, (e.g. Data Sets to be uploaded to the pump, Event Reports to be downloaded from the pump and the pump to be monitored remotely via a suitable central monitoring or computer system).



**The nurse call interface provides a remote backup to the internal audible alarm. It should not be relied upon to replace monitoring of the internal alarm.**

**Refer to the Technical Service Manual for further information regarding the RS232 interface. Since it is possible to control the syringe pump using the RS232 interface at some distance from the pump and hence remote from the patient, responsibility for the control of the pump is vested in the software run on the computer control system.**

**The assessment for the suitability of any software used in the clinical environment to control or receive data from the pump lies with the user of the equipment. This software should include detection of the disconnection or other failure of the RS232 cable. The protocol is detailed in the Alaris® Syringe Pump Communications Protocol (1000PB01088) and is for general information only.**

**Any connected analogue and digital components are required to meet IEC/EN60950 for data processing and IEC/EN60601 for medical devices. Anyone connecting additional devices to the signal input or output is a system configurator and responsible for meeting the requirements of the system standard IEC/EN60601-1-1.**

### IrDA

<b>Baud Rate</b>	38.4 kBaud
<b>Start Bits</b>	1 Start Bit
<b>Data Bits</b>	8 Data Bits
<b>Parity</b>	No Parity
<b>Stop Bits</b>	1 stop bit

## RS232 / Nurse call Connection Data

### *Nurse call Specification -*

<b>Connector</b>	D Type - 9 Pin
<b>TXD/RXD</b>	EIA RS232-C Standard
<b>TXD Output Voltage Range</b>	Minimum: -5V (mark), +5V (space) Typical: -7V (mark), +7V (space) with 3kΩ load to ground
<b>RXD Input Voltage Range</b>	-30V - +30V max.
<b>RXD Input Thresholds</b>	Low: 0.6V minimum / High: 3.0V maximum
<b>RXD Input Resistance</b>	3kΩ minimum
<b>Enable</b>	Active, Low: -7V to -12V Active, High: +7V to +12V, powers up the isolated RS232 circuitry  Inactive: Floating/open circuit, allows isolated RS232 circuitry to power down.
<b>Isolation Socket/Pump</b>	1.5kV (dc, or ac peak)
<b>Baud Rate</b>	38.4 kBaud
<b>Start Bits</b>	1 Start Bit
<b>Data Bits</b>	8 Data Bits
<b>Parity</b>	No Parity
<b>Stop Bits</b>	1 stop bit
<b>Nurse Call Relay Contacts</b>	Pins 1, 8 + 9, 30V dc, 1A rating

### *Typical Connection Data -*

- 1 Nurse call (Relay) Normally Closed (NC C)
- 2 Transmit Data (TXD) Output
- 3 Received Data (RXD) Input
- 4 Power Input (DSR)
- 5 Ground (GND)
- 6 Not used
- 7 Power Input (CTS)
- 8 Nurse call (Relay) Normally open (NC O)
- 9 Nurse call (Relay) Common (NC COM)

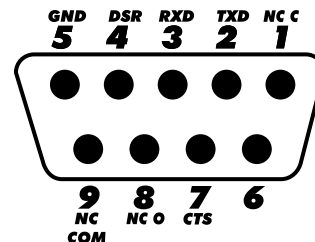

# Trumpet Curves & Start-up Curves

In this pump, as with all infusion systems, the action of the pumping mechanism and variations in individual syringes cause short-term fluctuations in rate accuracy.

The following curves show typical performance of the system in two ways: 1) the delay in onset of fluid flow when infusion commences (start-up curves), and 2) the accuracy of fluid delivery over various time periods is measured (trumpet curves).

The start-up curves represent continuous flow versus operating time from the start of the infusion. They exhibit the delay in onset of delivery due to mechanical compliance and provide a visual representation of uniformity. Trumpet curves are derived from the second hour of this data. Tests performed per IEC/EN60601-2-24 standard.

Trumpet curves are named for their characteristic shape. They display discrete data averaged over particular time periods or 'observation windows', not continuous data versus operating time. Over long observation windows, short term fluctuations have little effect on accuracy as represented by the flat part of the curve. As the observation window is reduced, short term fluctuations have greater effects as represented by the "mouth" of the trumpet.

Knowledge of system accuracy over various observation windows may be of interest when certain drugs are being administered. Short term fluctuations in rate accuracy may have clinical impact depending on the half-life of the drug being infused, therefore the clinical effect cannot be determined from the trumpet curves alone.



**Start-up and trumpet curves may not be indicative of operation under negative pressure.**

**Differences in factors such as size and plunger force in compatible syringes produced by other manufacturers can cause variations in accuracy and trumpet curves as compared to those represented. Additional curves for compatible syringes are available upon written request.**

**For applications where flow uniformity is a concern, rates of 1.0 ml/h or above are recommended.**

**Start-up Trend. BD Plastipak 50ml @ 0.1ml/h**

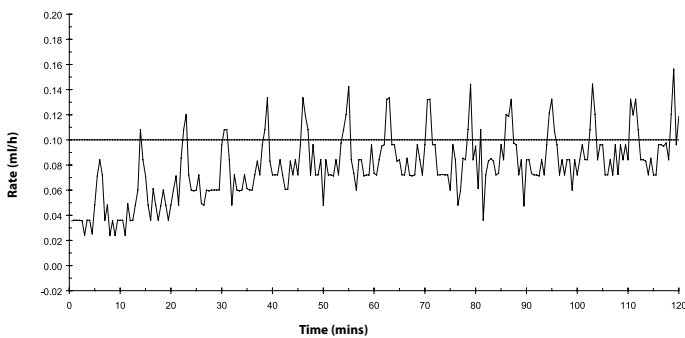

**Trumpet Curve. BD Plastipak 50ml @ 0.1ml/h**

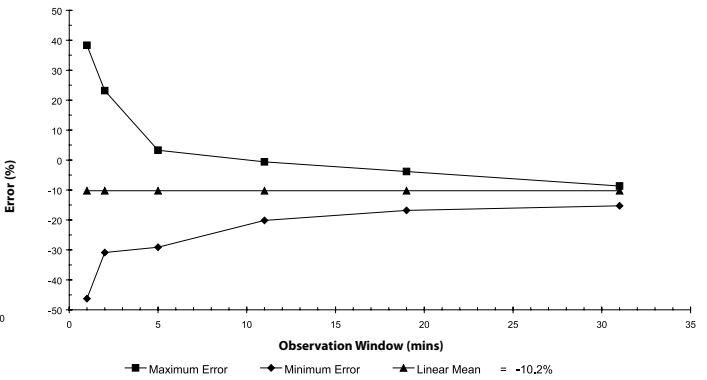

**Start-up Trend. BD Plastipak 50 ml @ 1.0 ml/h**

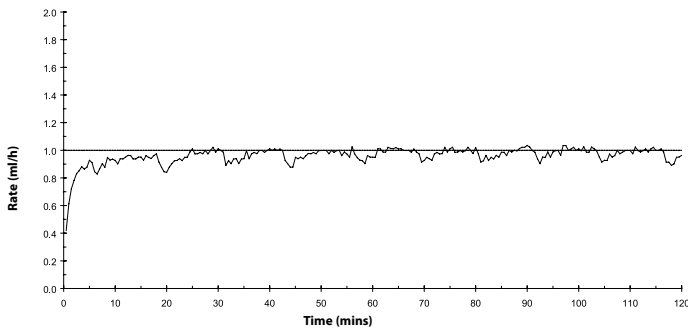

**Trumpet Curve. BD Plastipak 50 ml @ 1.0 ml/h**

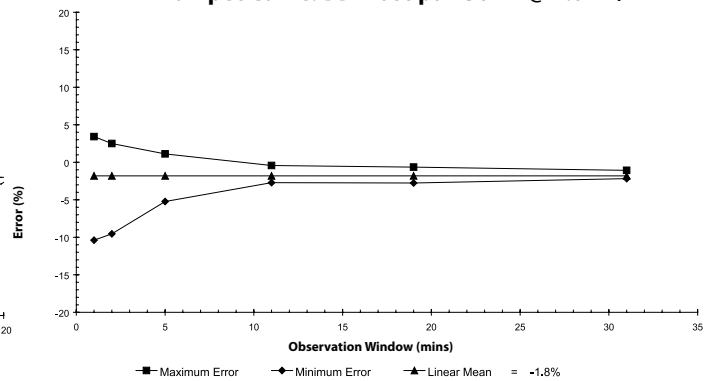

**Start-up Trend. BD Plastipak 50 ml @ 5.0 ml/h**

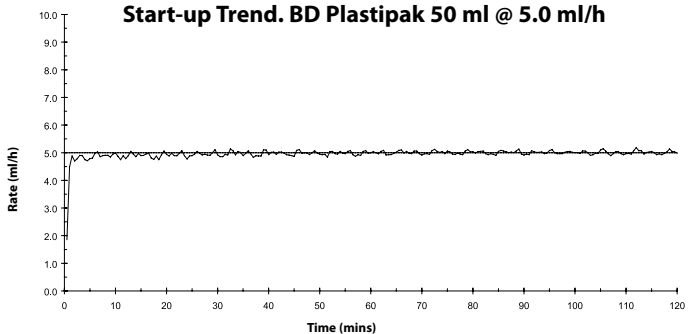

**Trumpet Curve. BD Plastipak 50 ml @ 5.0 ml/h**

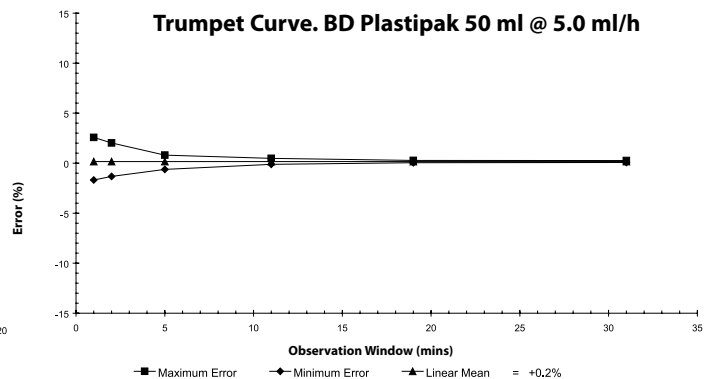

### **Spare Parts**

A comprehensive list of spare parts for this pump is included within the Technical Service Manual.

The Technical Service Manual (1000SM00001) is now available in electronic format on the World Wide Web at :-

[www.carefusion.co.uk/alaris-technical/](http://www.carefusion.co.uk/alaris-technical/)

A username and password are required to access our manuals. Please contact local customer services representative to obtain login details.

<b>Part Number</b>	<b>Description</b>
1000SP01122	Internal Battery Pack
1001FAOPT91	AC Power Lead - UK
1001FAOPT92	AC Power Lead - European

### **Guardrails® Safety Software**

The following items may be useful when using the Alaris® GH Guardrails® Syringe Pump.

<b>Part Number</b>	<b>Description</b>
1000SP00594	Guardrails® Editor PC Software Kit

## Service Contacts

For service contact your local Affiliate Office or Distributor.

<b>AE</b>	<b>DE</b>	<b>HU</b>	<b>PT</b>
CareFusion, PO Box 5527, Dubai, United Arab Emirates.	CareFusion, Tullastr. 8-12 69126 Heidelberg, Deutschland.	CareFusion, Döbrentei tér 1, H-1013 Budapest, Magyarország.	CareFusion, Avda. São Miguel, 296 Atelier 14 2775-751 Carcavelos, Lisboa Portugal
Tel: (971) 4 28 22 842	Tel: (49) 6221 305 0	Tel: (36) 1 488 0232 Tel: (36) 1 488 0233	Tel: +351 219 152 593
Fax: (971) 4 28 22 914	Fax: (49) 6221 305 216	Fax: (36) 1 201 5987	Fax: +351 219 152 598
<b>AU</b>	<b>DK</b>	<b>IT</b>	<b>SE</b>
CareFusion, 3/167 Prospect Highway, PO Box 355 Seven Hills, NSW 2147, Australia.	CareFusion, Firskovvej 25 B, 2800 Lyngby, Danmark.	CareFusion, Via Ticino 4, 50019 Sesto Fiorentino, Firenze, Italia.	CareFusion, Marieviksgatan 25, Box 47204 117 43 Stockholm Sverige
Tel: (61) 1800 833 372	Tlf. (45)70 20 30 74	Tél: (39) 055 30 33 93 00	
Fax: (61) 1800 833 518	Fax. (45)70 20 30 98	Fax: (39) 055 34 00 24	
<b>BE</b>	<b>ES</b>	<b>NL</b>	<b>US</b>
CareFusion, Erembodegem-Dorp 86 B-9320 Erembodegem Belgium.	CareFusion, Edificio Veganova, Avenida de La Vega, nº1, Bloque 1 - Planta 1, 28108 Alcobendas, Madrid, España.	CareFusion, De Molen 8-10, 3994 DB Houten, Nederland.	CareFusion, 10020 Pacific Mesa Blvd., San Diego, CA 92121, USA.
Tel: +32 (0) 2 267 38 99	Tel: (34) 902 555 660	Tel: +31 (0)30 2289 711	Tel: (1) 800 854 7128
Fax: +32 (0) 2 267 99 21	Fax: (34) 902 555 661	Fax: +31 (0)30 2289 713	Fax: (1) 858 458 6179
<b>CA</b>	<b>FR</b>	<b>NO</b>	<b>ZA</b>
CareFusion, 235 Shields Court, Markham, Ontario L3R 8V2, Canada.	CareFusion, Parc d'affaire le Val Saint Quentin 2, rue René Caudron 78960 Voisins le Bretonneux France	CareFusion, Fjordveien 3 1363 HØVIK Norge.	CareFusion, Unit 2 Oude Molen Business Park, Oude Molen Road, Ndabeni, Cape Town 7405, South Africa.
Tel: (1) 905-752-3333	Tél: (33) 01 30 02 81 41	Tel: (47) 64 00 99 00	Tel: (27) (0) 860 597 572 Tel: (27) 21 510 7562
Fax: (1) 905-752-3343	Fax: (33) 01 30 02 81 31		Fax: (27) 21 5107567
<b>CH</b>	<b>FI</b>	<b>NZ</b>	
BD Switzerland, Terre-Bonne Business Park , Building A4 Route de Crassier 17, 1262 Eysins Switzerland	CareFusion, Kuortaneenkatu 2, 00510 Helsinki	CareFusion, 14B George Bourke Drive, Mt Wellington 1060, PO Box 14-518, Panmure 1741, Auckland, New Zealand	
Phone: ++41 21 556 3000	Tel: +358 207871 090	Tel: 09 270 2420 Freephone: 0508 422734	
Fax: ++41 21 556 3099		Fax: 09 270 6285	
<b>CN</b>	<b>GB</b>	<b>PL</b>	
康尔福盛（上海）商贸有限公司 地址：上海市浦东新区张杨路 500号24楼E. F. G. H单元	BD, 1030 Winnersh Triangle, Eskdale Road, Winnersh, RG41 5TS United Kingdom.	Becton Dickinson Polska Sp. z o.o. ul. Osmańska 14 02-823 Warszawa Polska.	
电话： +86-21-60369369 400 878 8885	Tel: (44) 0800 917 8776	Tel: (48) 22 377 11 00	
传真： +86-21-60369399		Fax: (48) 22 377 11 01	

Rev. Q

Alaris, Guardrails, SmartSite and IVAC are registered trademarks of CareFusion Corporation or one of its affiliates. All rights reserved. All other trademarks are property of their respective owners.

© 2018 CareFusion Corporation or one of its affiliates. All rights reserved.

This document contains proprietary information of CareFusion Corporation or one of its affiliates, and its receipt or possession does not convey any rights to reproduce its contents, or to manufacture or sell any product described. Reproduction, disclosure, or use other than for the intended purpose without specific written authorization of CareFusion Corporation or one of its affiliates is strictly forbidden.



CareFusion Switzerland 317 Sarl,  
A-One Business Centre, ZA Vers –La-  
Pièce n° 10, CH-1180, Rolle



CareFusion UK 305 Ltd., The Crescent,  
Jays Close, Basingstoke, Hampshire,  
RG22 4BS, UK

1000DF00332 Issue 6