



 **Gemma
Group**

Premier
Single-head cutting-off machine

Single-head cutting-off machine with front blade Ø 500/600 mm

TECHNICAL INFO

Structure

- Electro-welded steel basement
- 2 horizontal pneumatic clamps
- pneumatic head tilting
- mechanical stops for quick angle selection 45° / 90° / 135°

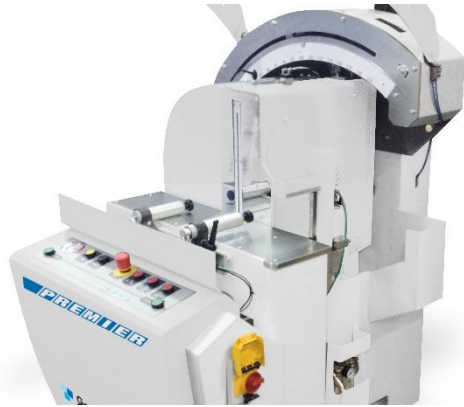

Cutting unit

- cutting angles display on graduated ruler
- Venturi lubrication system
- widia blade



Power supply

Electric power	400 V / 50 Hz
Motor power	2,2 kW (500 mm) – 4 kW (600 mm)
Air compressed supply	7 Bar
Air consumption per cycle	18 NI



Cutting unit

Blade diameter	500 / 600 mm
Shaft diameter	30 mm
Blade revolutions	2.800 giri/min
Max. cutting speed	6 m/min
Blade output management	oleopneumatica
Cutting angles	20°-135°

Safety

- integral cutting area protections with automatic opening and closing
- complies with CE safety regulations as standard

Cutting capacity

		
90° (500 mm / 600 mm)	155x155 / 190x190 mm	180x150 – 250x100 / 230x180 – 300x120 mm
45° (500 mm / 600 mm)	140x140 / 170x170 mm	180x100 – 200x65 / 160x180 – 210x120 mm

General specifications



500 mm
600 mm



2,2 kW
4 kW



520 kg
670 kg

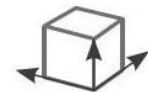

1.400x960x1.650 mm
1.550x960x1.650 mm

Optionals

- Widia blade 500 mm (spare)
- Widia blade 600 mm (spare)
- 1 pneumatic vertical clamp
- USA-CANADA setup (UL-CSA standards)
- Autotransformer for special voltage
- Ocean freight packaging

Machine layout

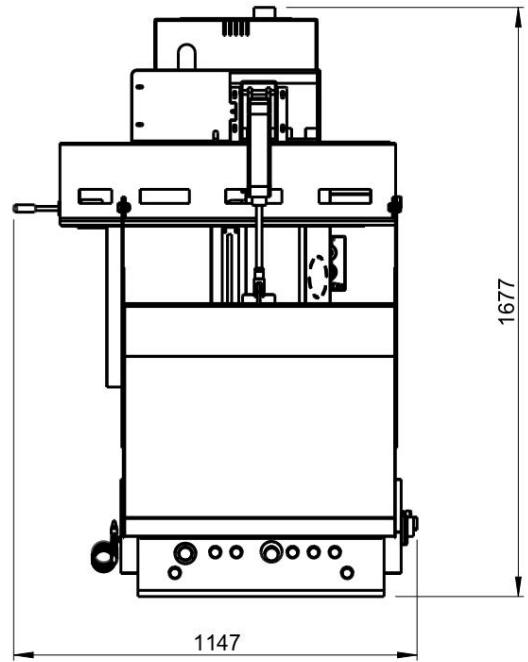
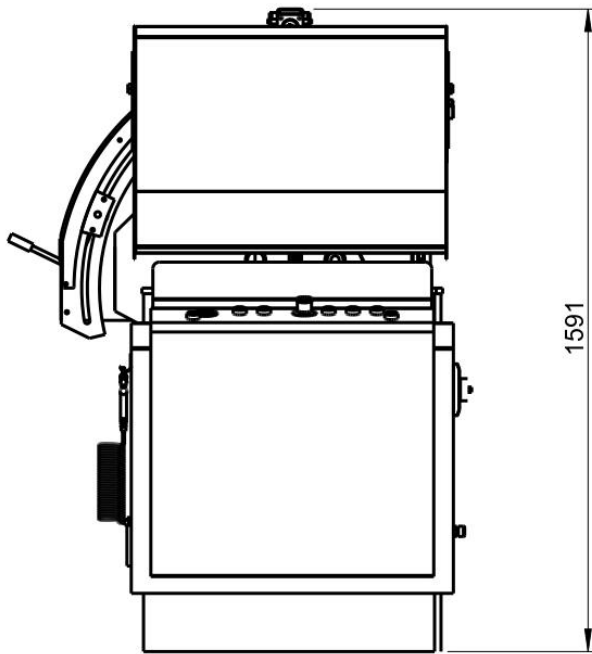

Cutting diagrams

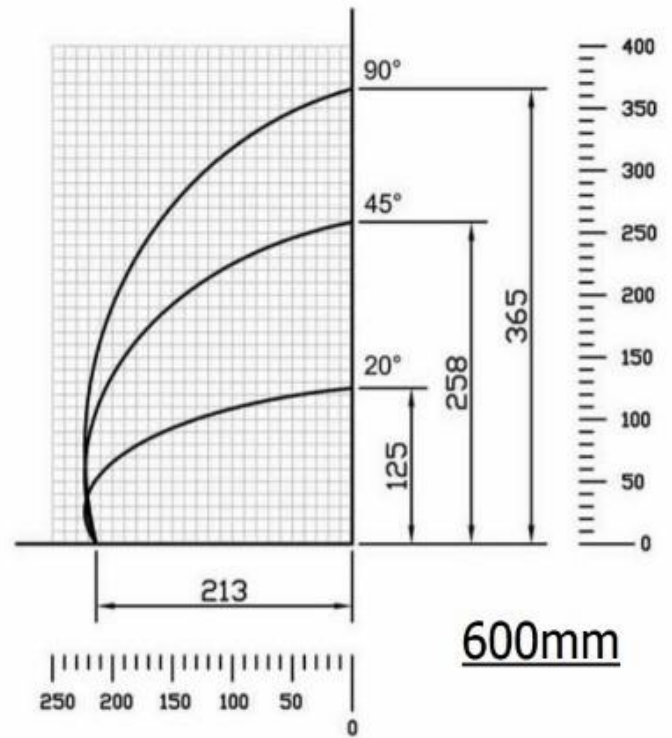
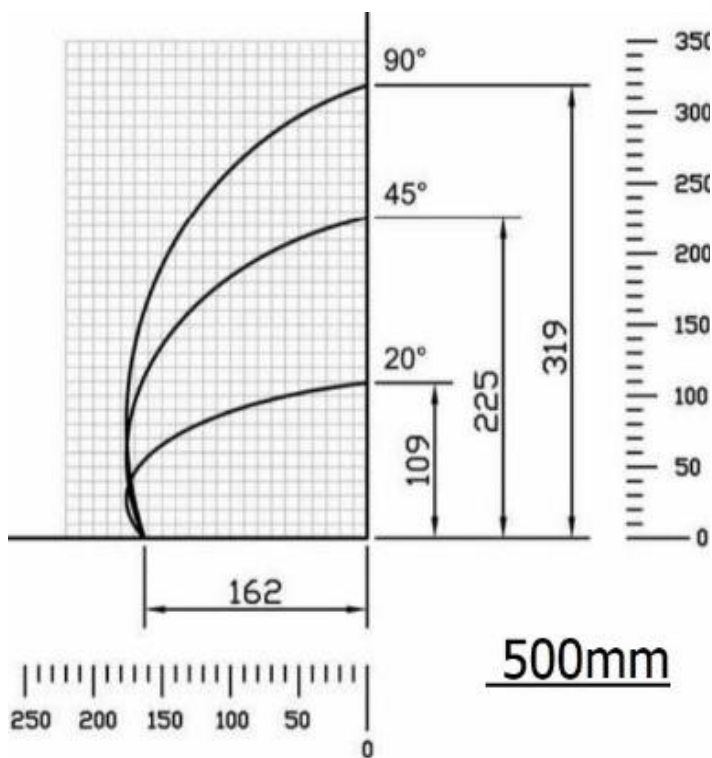



Gemma Group srl
Via Dante Alighieri, 6
47853 Coriano – Rimini – Italy
Tel. +39 0541 905811
www.gemma-group.com
email: info@gemma-group.com