



Models
N/6.5E
N/6.5G



Model N/6.5E

Models N/6.5E

N/6.5G

Standard Features

- 18 to 24 bird capacity (3½lb +)
- Countertop unit, minimal space required
- Front and rear pivot doors
- Double rotation for genuine rotisserie cooking (Drums and spits rotate)
- Allows combination of spits and rotating baskets to cook simultaneously
- Batch cooking with self basting
- Water drip tray for humidified cooking
- Quadrant lighting enhances the appeal of the cooked product
- 6 position drum is standard

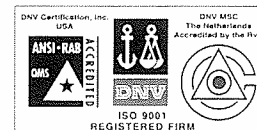

Options

- Rotating basket spits
- 7 spit drum – for larger capacity 21 to 28 bird capacity (3½lb less)
- Standard spit and skewers
- Angle spits – V spits
- Thermowave spits
- Stand
- Steel Back
- Custom Color

Technical Data	Model 6.5E	Model 6.5G
Cooking Type	Batch	Batch
Power Supply	Electric	Gas
Supply Voltage (Please Specify)	208 ~ 240	120
Phase • Frequency (Special Voltages Available)	3+N • 60 Hz	Single • 60 Hz
# Elements • kW • Total Element kW	5 • 2 • 10	N/A
Lights • Wattage Each • Total Lighting Wattage	4 • 25 • 100	4 • 25 • 100
Motor Wattage	64	64
Digital Timer Wattage	5	5
Amperage Three Phase @ 208V, 220V, 240V	28 • 26 • 24	Special Order
Amperage @ 120V	N/A	2
BTU's • Natural • Propane	N/A	40,000 • 40,000
Flue Dimension	N/A	6" x 2 ³ / ₄ "
Nominal Gas Pressure: Natural • Propane	N/A	5" • 11"
Gas Connection (female end required)	N/A	1/2"
Net Weight	315	345
Dimensions:		
A	40 ¹ / ₂ "	40 ¹ / ₂ "
B	35 ¹ / ₂ "	39 ¹ / ₂ "
C	27 ¹ / ₂ "	27 ¹ / ₂ "
D	Electrical Inlet	1/2" Gas Inlet
Chicken Capacity – standard drums	18 - 24	18 - 24
Chicken Capacity – 7 position drums	21 - 28	21 - 28
Clearance From Adjacent Walls	13"	13"
Clearance From Rear Wall W/Steel Back	1"	1"

Models N/6.5E N/6.5G

Model N/6.5E Shown

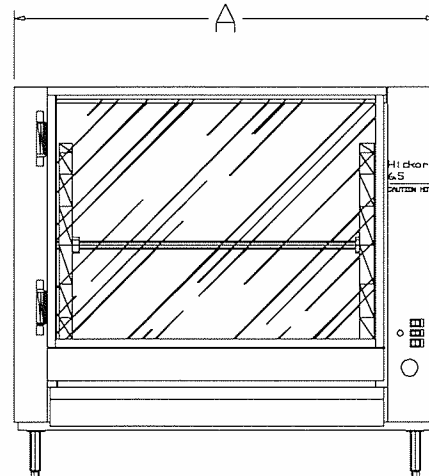

Front View

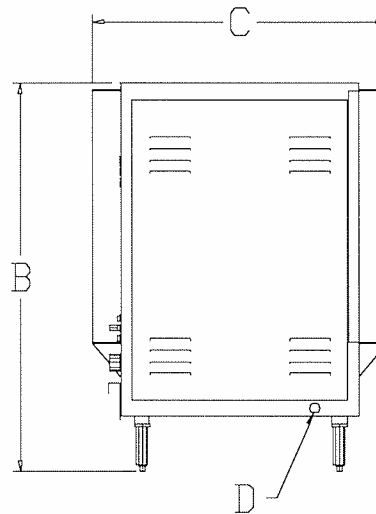

Side View

Ventilation

Electric units do not normally require air evacuation. However since the surrounding environment may get hot, a hood may be useful.

Drive Mechanism

A sprocket gear attached to gear motor drives a chain, which in turn drives a large sprocket gear on the central drive shaft. The drive wheel has individual drive gears which operate in a planetary action around a stationary gear.

Installation Requirements

Licensed electrician. HVAC specialist for air evacuation. Placement of this machine is critical since it is hot. Plan carefully. For pass thru applications adjacent walls must be approved. For non see thru application the control side surface is glass and the back door of the machine is stainless.

Front Facings

Machine is made with high grade polished stainless. Side boxes can be ordered in stainless or black finish. For an additional charge, facing can be painted to a different color.

Service, Maintenance, and Construction

Full side service panels allow easy access to all working parts. The N/6.5 is easily cleaned from front to back, enabling the user to meet all sanitary and hygienic requirements with a minimum of time and effort. Access to the planetary gears is available through the left side box. The interior cooking area is constructed completely of high-grade stainless steel. Insulation is complete on all top and side panels. Rigid box design ensures strength.

Safety

The vertical hinged, tempered glass service doors open completely and will gravity lock in the open and closed position. This system prevents operator injury with hot doors and also provides full access to baskets and spits. Electrical components are located behind the control panel in an area fully insulated from the interior cooking space. Control panel information with clear, legible graphics eliminate confusion for even the novice operator.

*Specifications are subject to change without notice. When ordering please specify voltage, phase and frequency requirements.



Hickory Industries, Inc. • 4900 Westside Avenue • North Bergen, NJ 07047
201-223-0050 • Fax 201-223-0950

www.hickorybbq.com • email: hickorybbqs@aol.com